



US00D582830S

(12) **United States Design Patent**
Musser

(10) **Patent No.:** **US D582,830 S**

(45) **Date of Patent:** **** Dec. 16, 2008**

(54) **VEHICLE WHEEL**

(74) *Attorney, Agent, or Firm*—Fulwider Patton LLP

(75) Inventor: **Scott Musser**, Chino Hills, CA (US)

(57) **CLAIM**

(73) Assignee: **Prestige Autotech Corporation**, Chino, CA (US)

The ornamental design for a vehicle wheel, as shown and described.

(**) Term: **14 Years**

DESCRIPTION

(21) Appl. No.: **29/317,357**

FIG. 1 is a perspective view of the vehicle wheel showing a first embodiment of my new design;

(22) Filed: **Apr. 28, 2008**

FIG. 2 is a front elevational view thereof;

(51) **LOC (8) Cl.** **12-16**

FIG. 3 is a cross-sectional view taken along the lines of 3—3 of FIG. 2;

(52) **U.S. Cl.** **D12/211**

(58) **Field of Classification Search** D12/204–213;
301/37.101, 64.101, 65, 64.201

FIG. 4 is a perspective view of the vehicle wheel showing a second embodiment of my new design;

See application file for complete search history.

FIG. 5 is a front elevational view thereof;

(56) **References Cited**

FIG. 6 is a cross-sectional view taken along the lines of 6—6 of FIG. 5.

U.S. PATENT DOCUMENTS

D456,332 S *	4/2002	Vian	D12/211
D504,101 S *	4/2005	Pfeiffer	D12/211
D505,375 S *	5/2005	Kushartanto	D12/211
D514,052 S *	1/2006	Walbey, Jr.	D12/211
D531,953 S *	11/2006	Aoki	D12/211
D536,655 S *	2/2007	Kim	D12/211
D539,205 S *	3/2007	Hosoi	D12/211
D543,922 S *	6/2007	Young	D12/209
D545,749 S *	7/2007	Young	D12/211
D548,164 S *	8/2007	Young	D12/211
D548,167 S *	8/2007	Groom	D12/211
D567,739 S *	4/2008	Kim	D12/211
D573,082 S *	7/2008	Young	D12/211

FIG. 7 is a perspective view of the vehicle wheel showing a third embodiment of my new design;

FIG. 8 is a front elevational view thereof;

FIG. 9 is a cross-sectional view taken along the lines of 9—9 of FIG. 8;

FIG. 10 is a perspective view of the vehicle wheel showing a fourth embodiment of my new design;

FIG. 11 is a front elevational view thereof; and,

FIG. 12 is a cross-sectional view taken along the lines of 12—12 of FIG. 11.

The broken line showing the environment is for illustrative purposes only and forms no part of the claimed design.

* cited by examiner

Primary Examiner—Stacia Cadmus

1 Claim, 12 Drawing Sheets

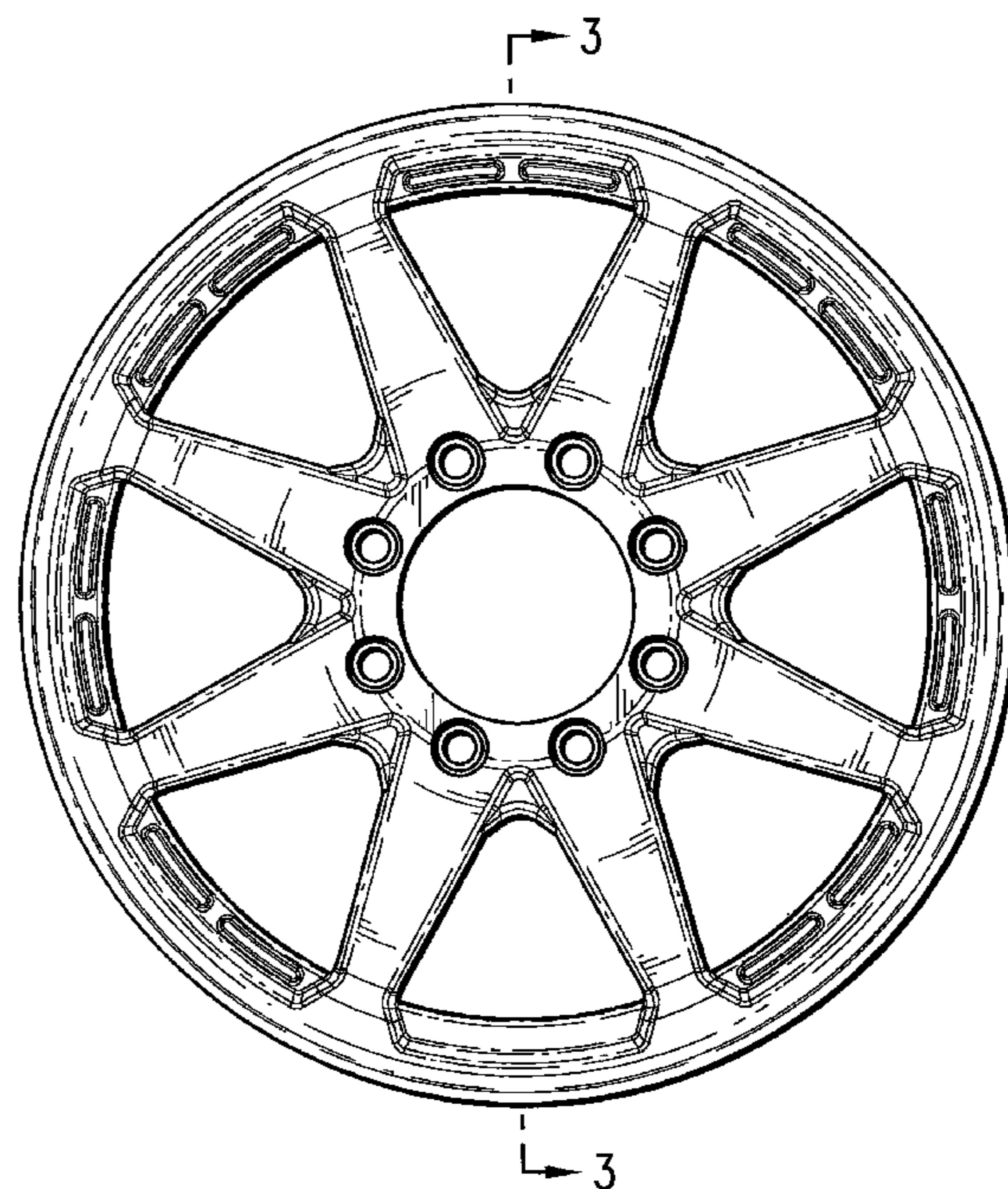
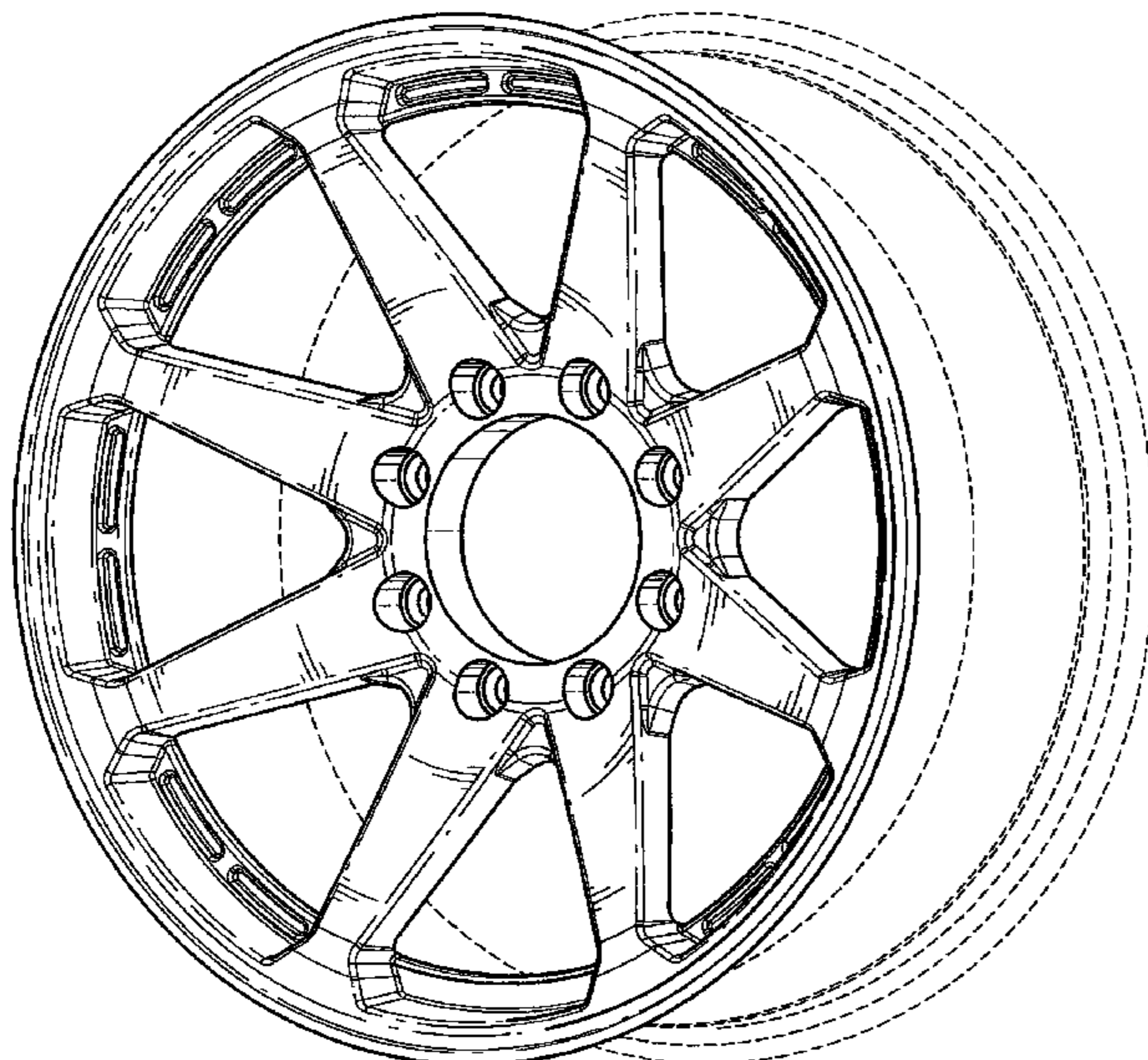

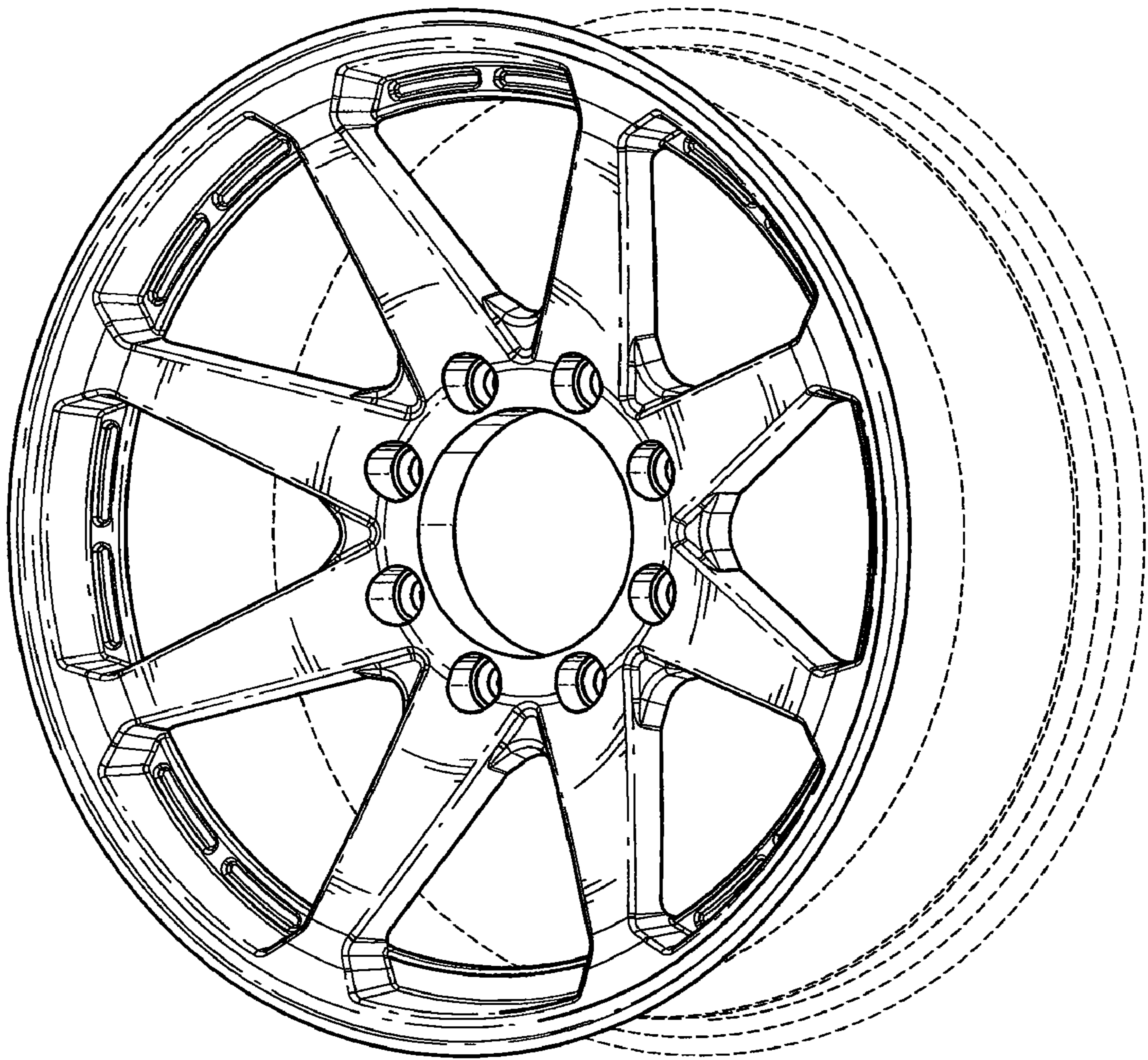

FIG. 1

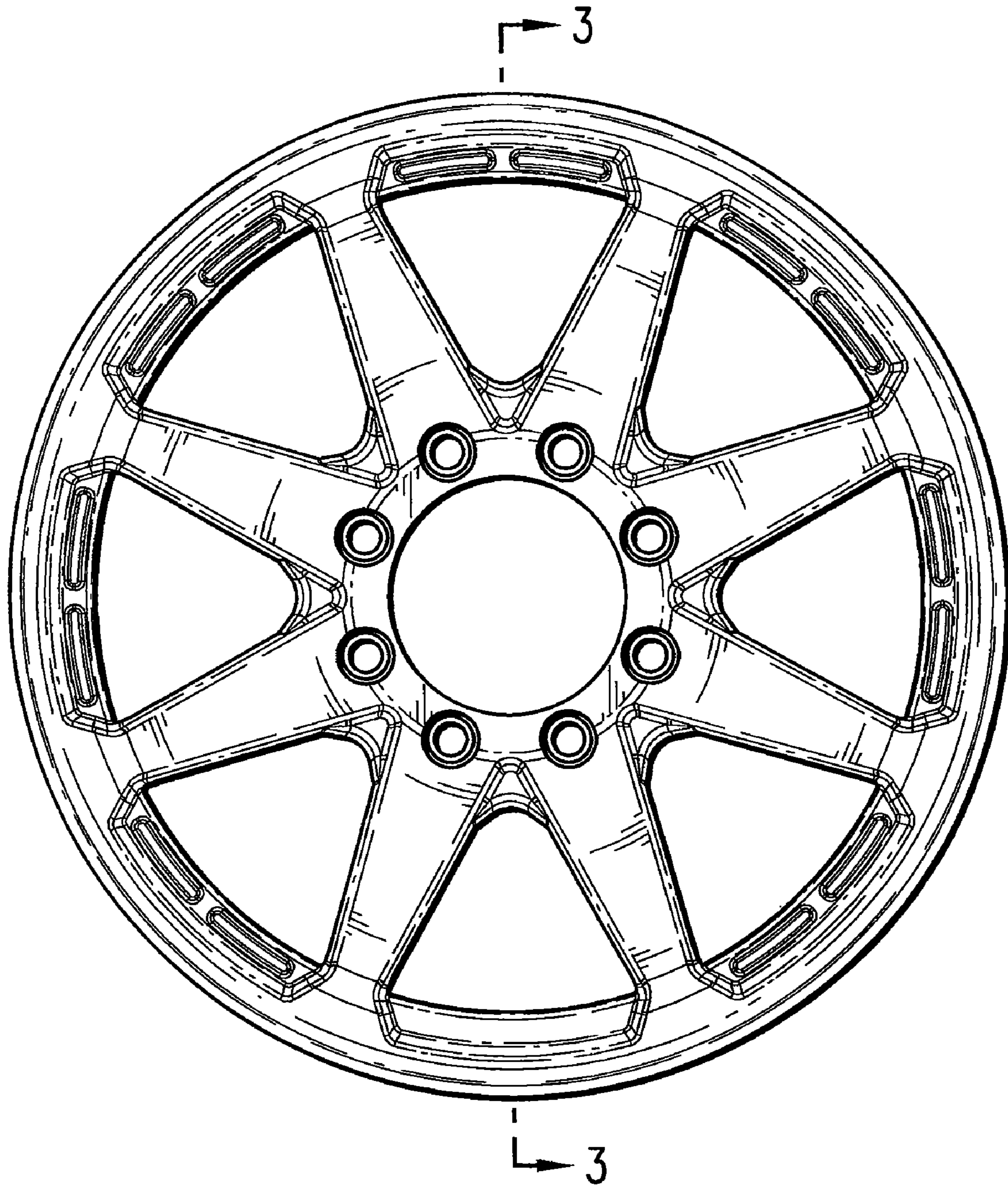

FIG. 2

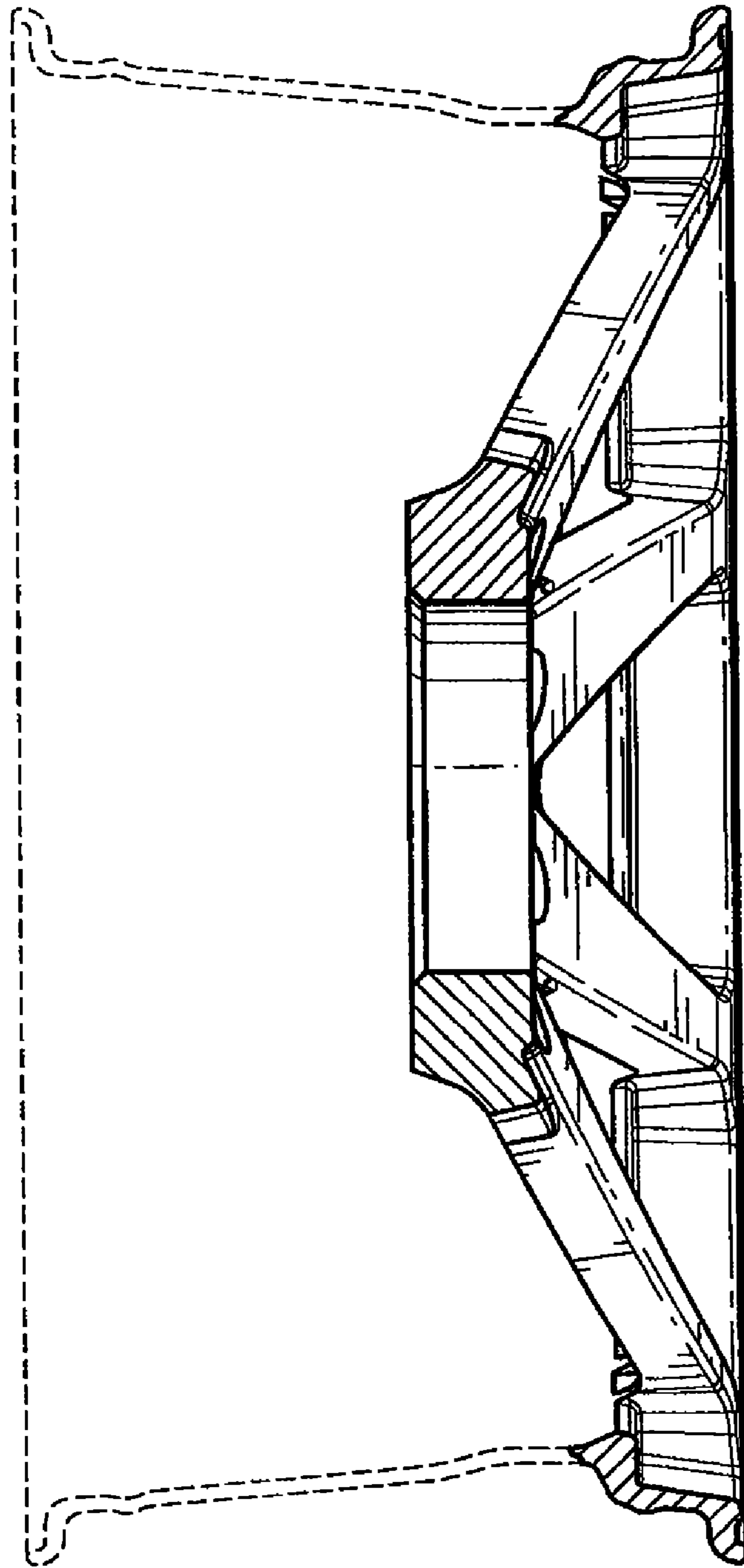

FIG. 3

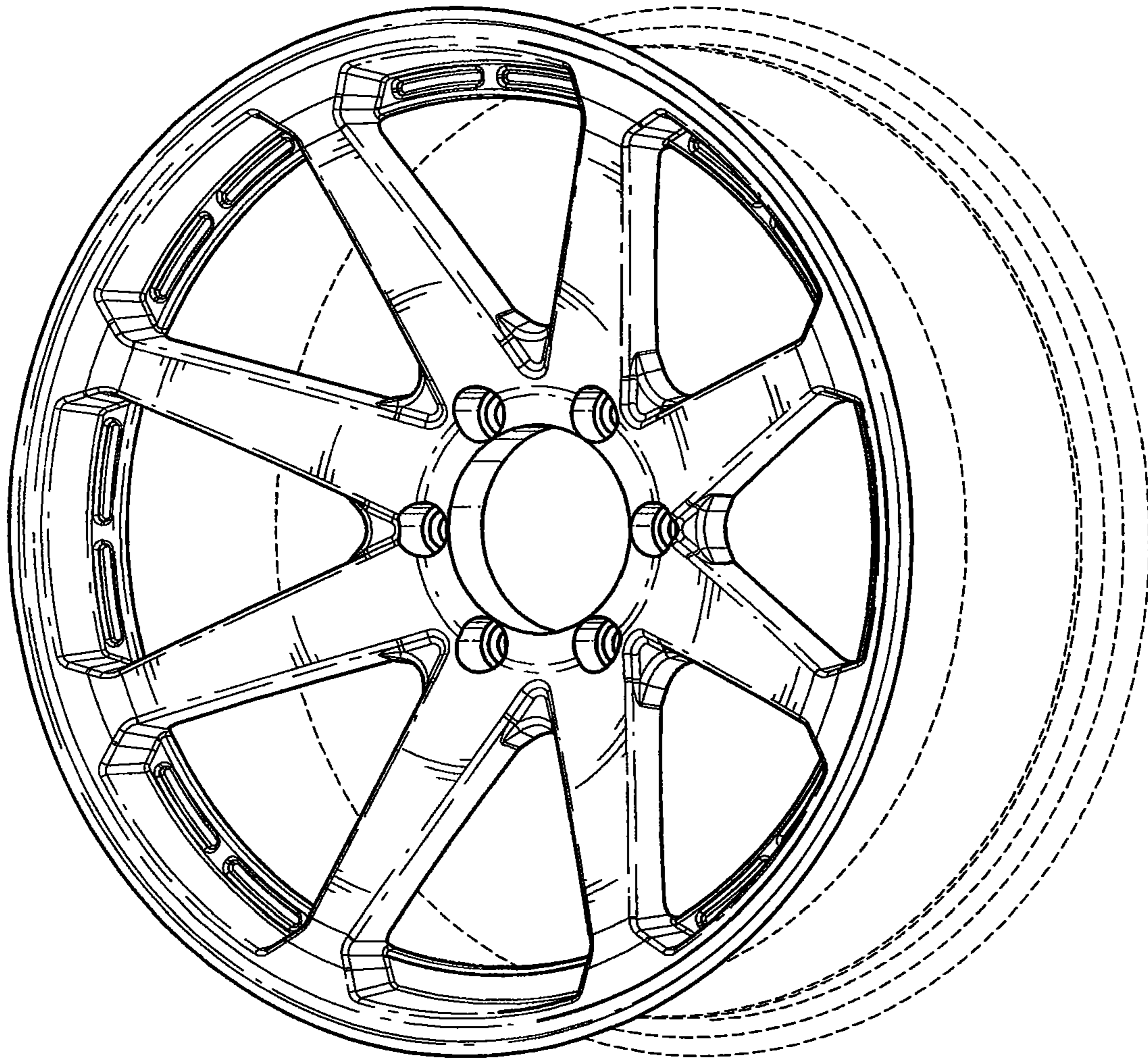

FIG. 4

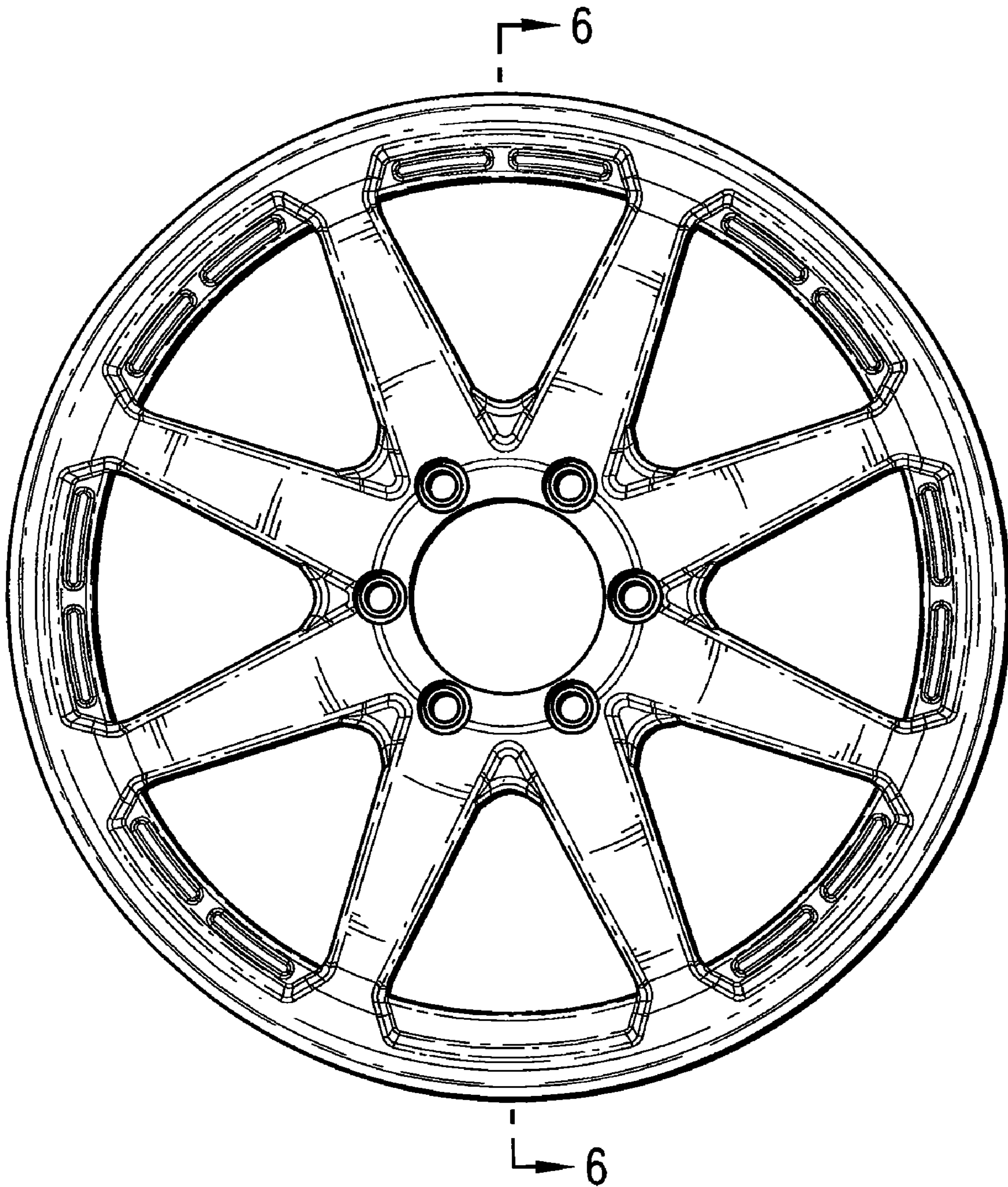

FIG. 5

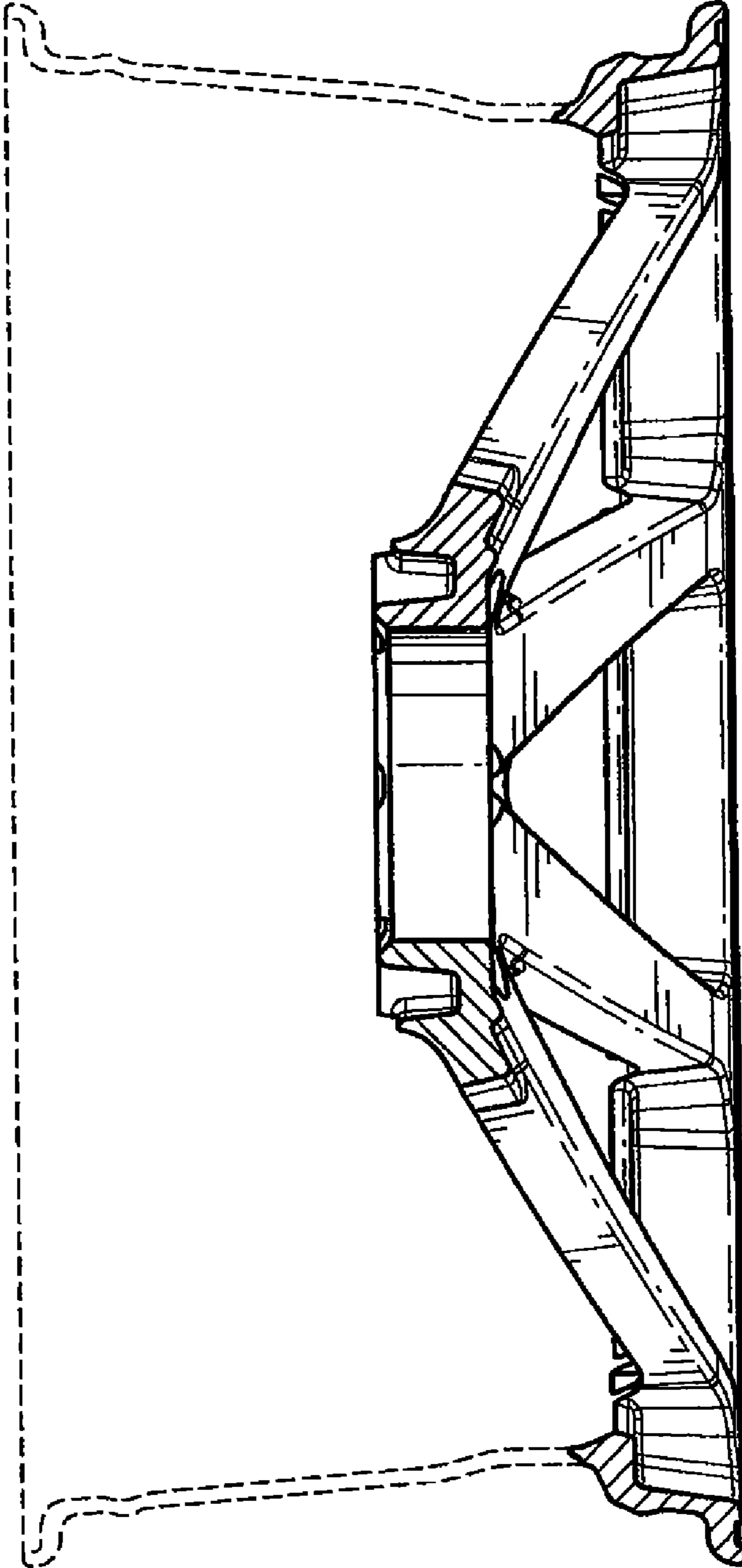

FIG. 6

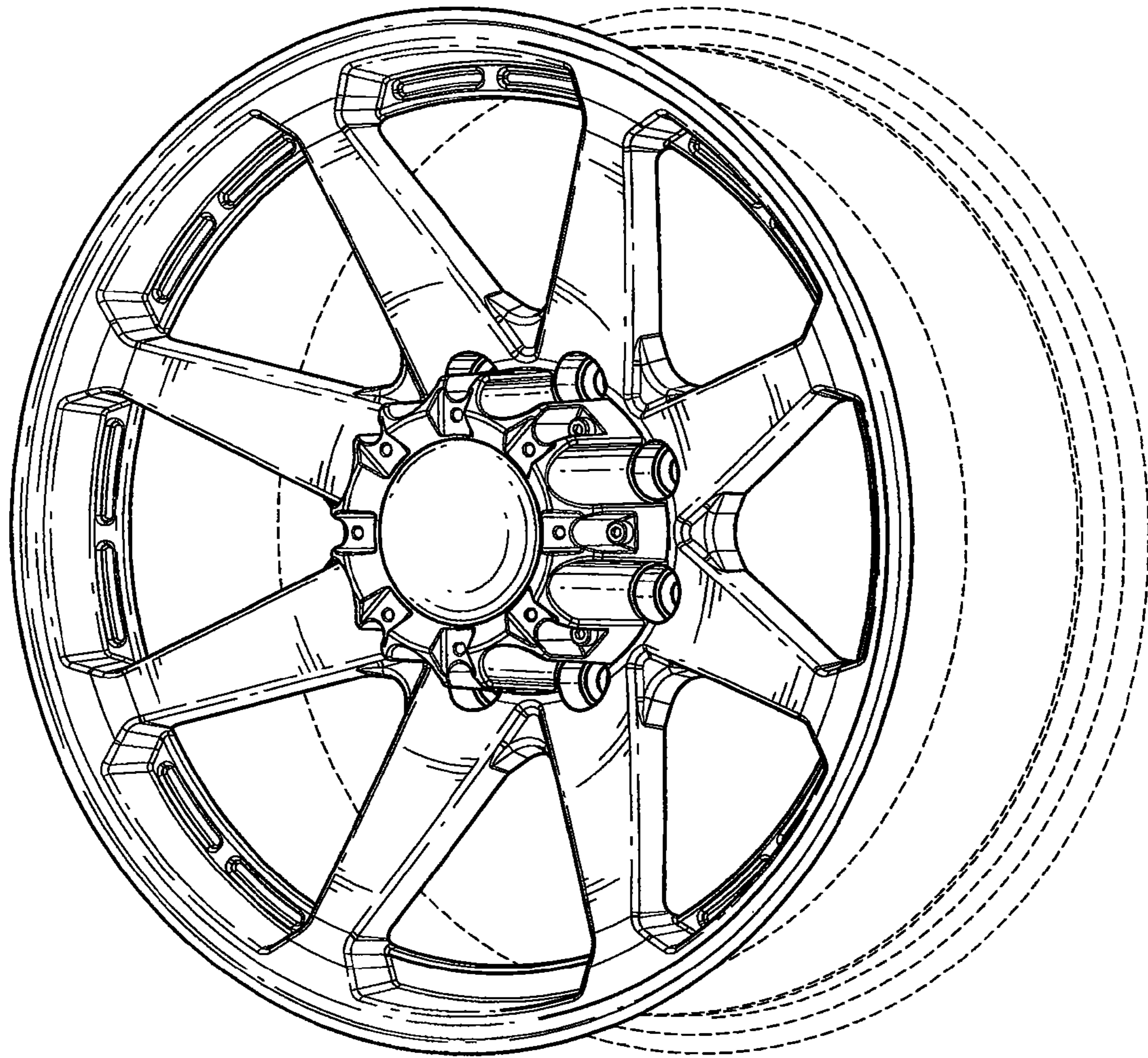

FIG. 7

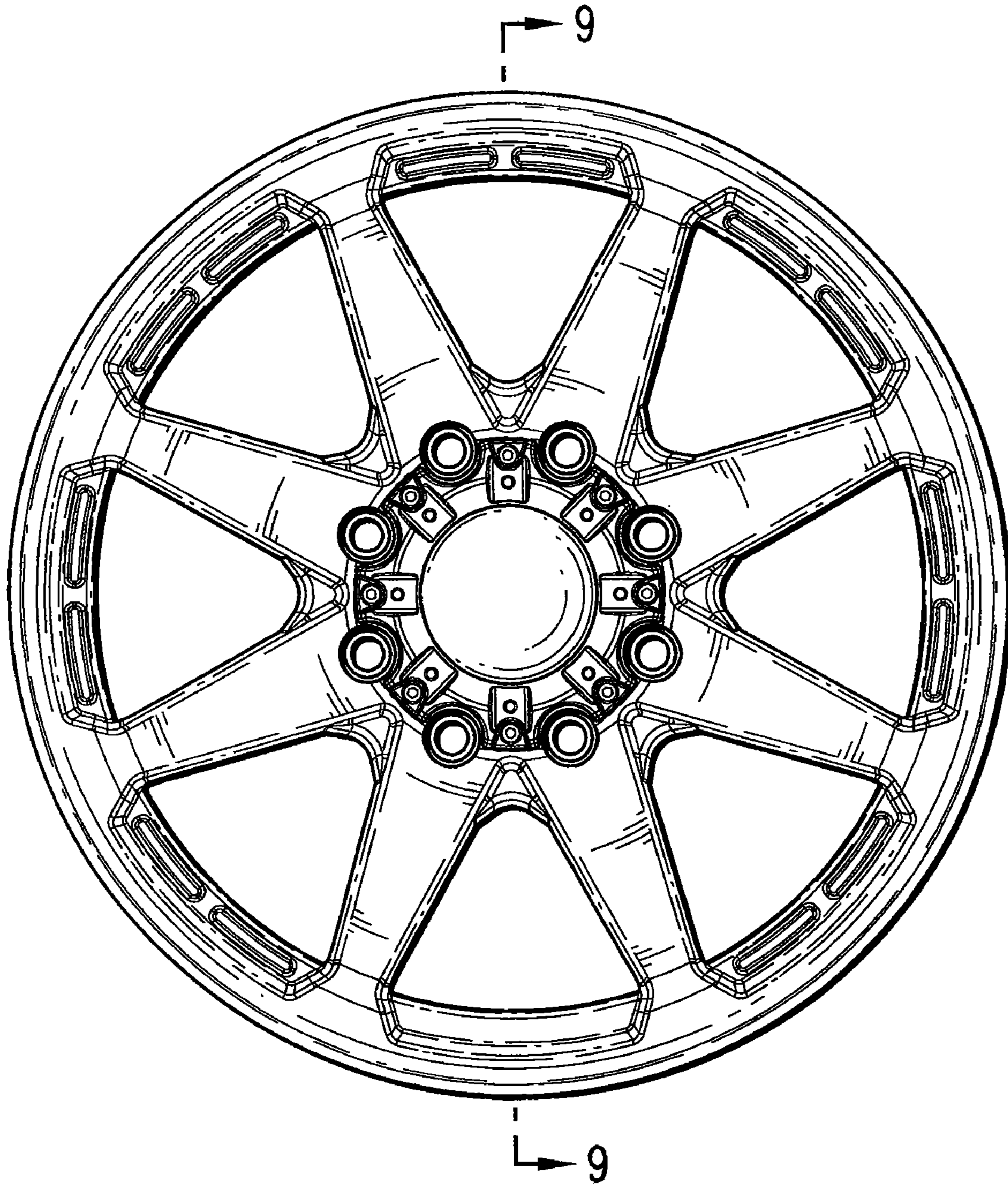

FIG. 8

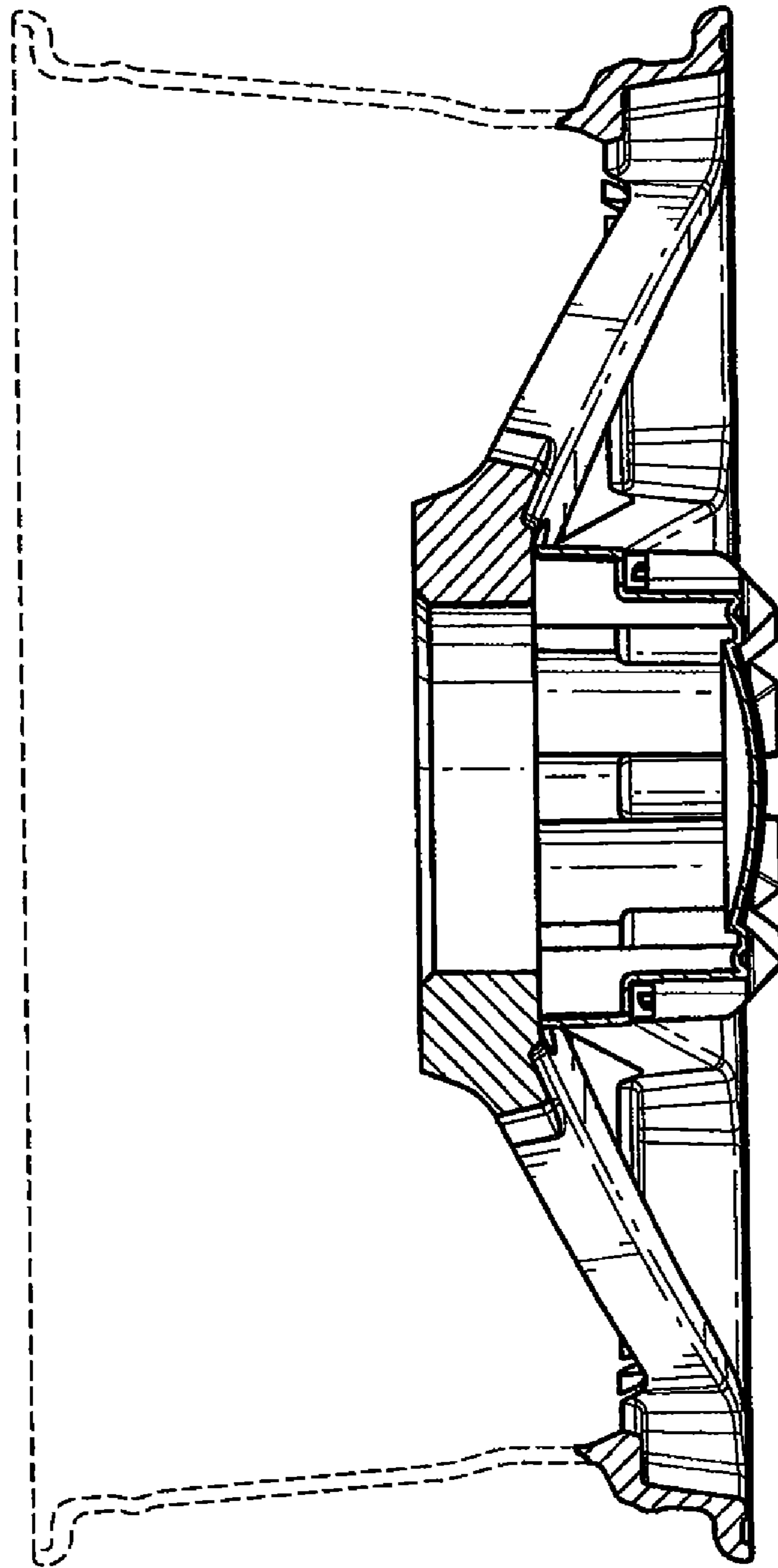

FIG. 9

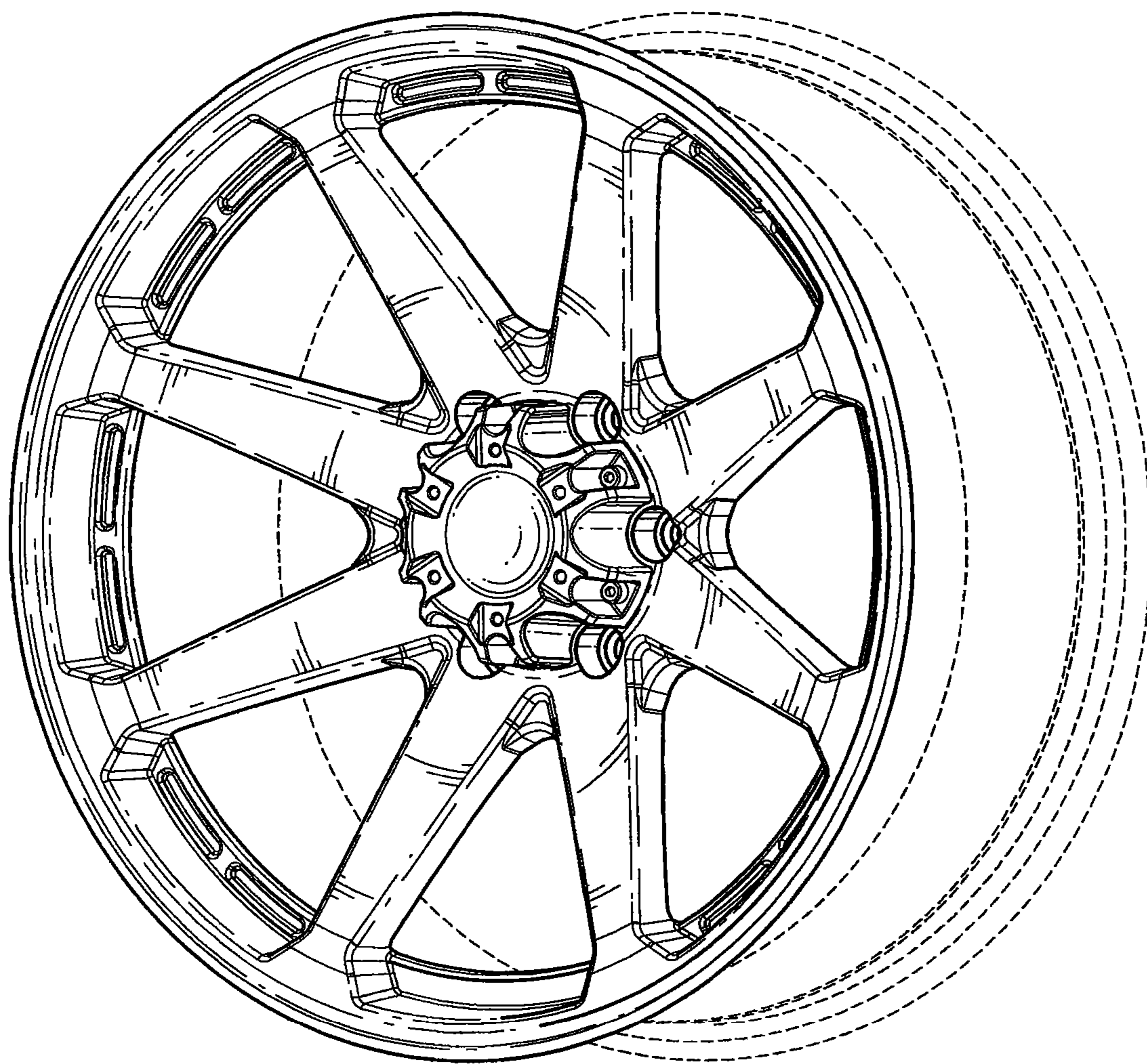

FIG. 10

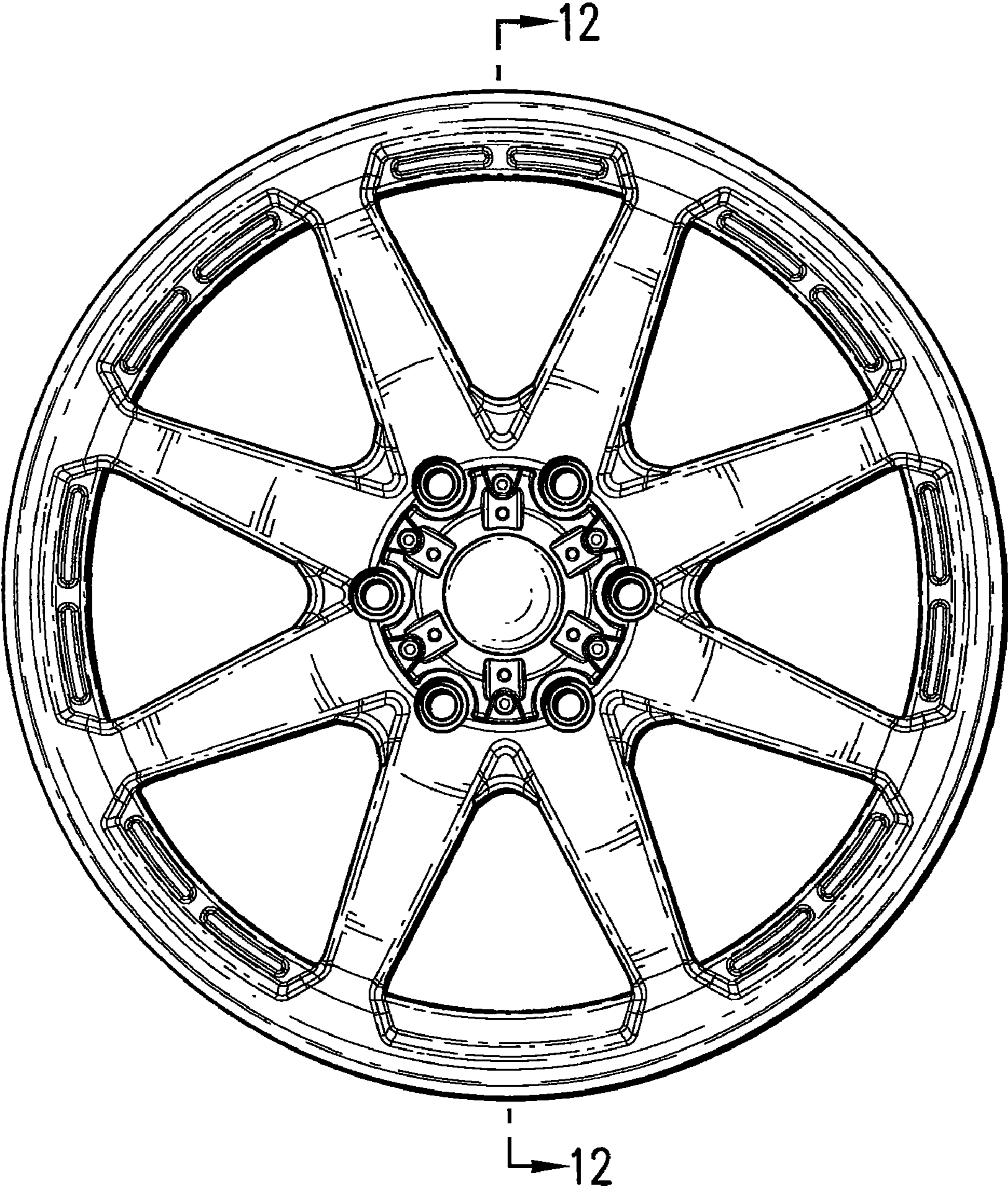

FIG. 11

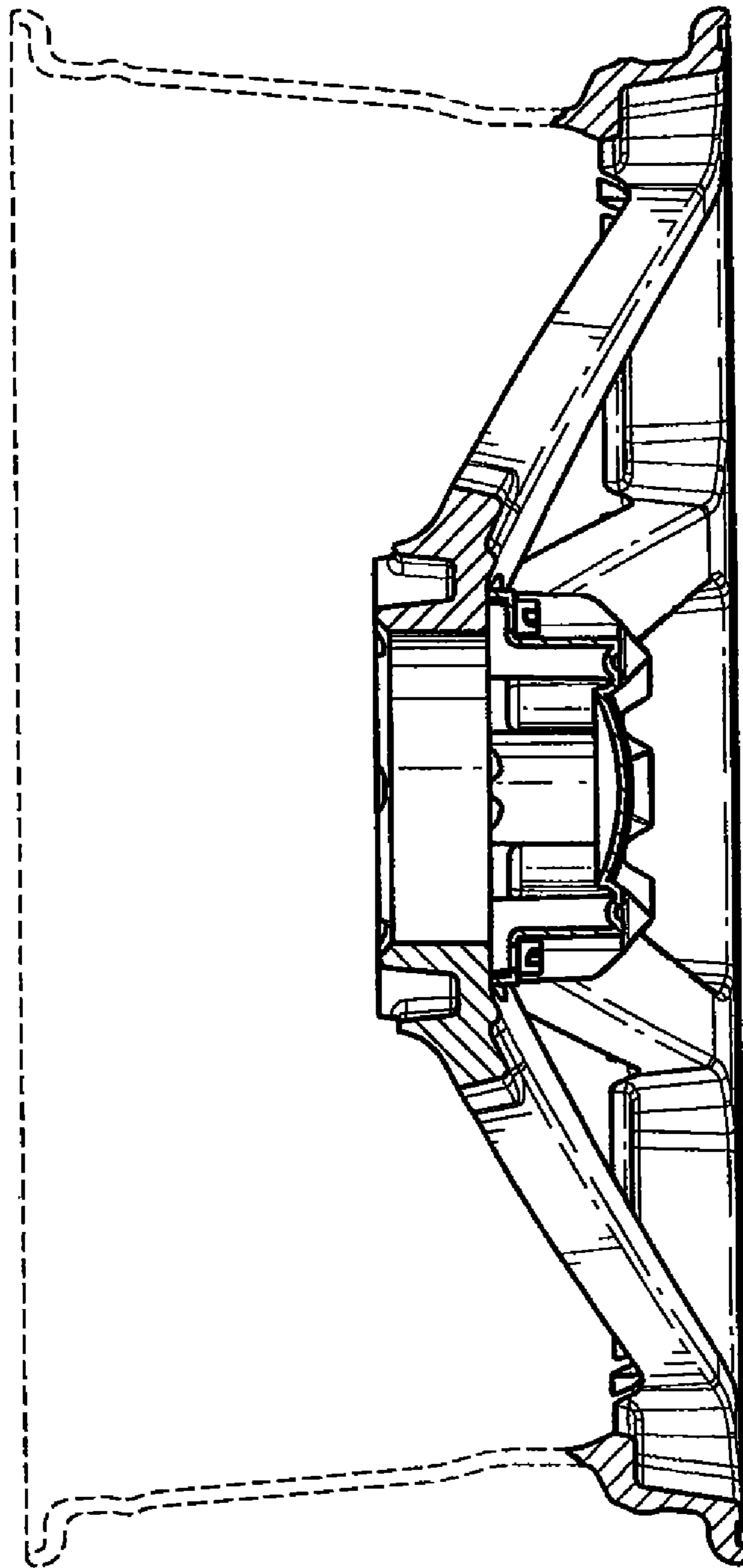

FIG. 12