



US00D582825S

(12) **United States Design Patent**
Logan

(10) **Patent No.:** **US D582,825 S**
(45) **Date of Patent:** **** Dec. 16, 2008**

(54) **VEHICLE FENDER FLARE**
(75) Inventor: **Geoffrey B. Logan**, Portland, OR (US)
(73) Assignee: **Bushwacker, Inc.**, Portland, OR (US)
(**) Term: **14 Years**
(21) Appl. No.: **29/292,852**
(22) Filed: **Oct. 29, 2007**

7,044,524 B2 5/2006 Luetze et al.
D522,427 S * 6/2006 Beigel et al. D12/196
7,222,884 B2 5/2007 Callan et al.
D548,660 S * 8/2007 Jenkins D12/196
D570,509 S * 6/2008 Logan D26/28

FOREIGN PATENT DOCUMENTS

GB 2046183 11/1980
JP 61057471 3/1986
JP 63130479 6/1988

OTHER PUBLICATIONS

Bushwacker Catalog No. 1205, 2006.

* cited by examiner

Primary Examiner—Philip S Hyder

Assistant Examiner—Cynthia Underwood

(74) *Attorney, Agent, or Firm*—Dascenzo Intellectual Property Law, P.C.

(51) **LOC (8) Cl.** **12-16**
(52) **U.S. Cl.** **D12/196; D12/184**
(58) **Field of Classification Search** D12/190–192,
D12/184, 181, 186; 280/152.1, 847–849,
280/851; 180/84; 293/DIG. 6; 296/185
See application file for complete search history.

(56) **References Cited**

U.S. PATENT DOCUMENTS

D50,345 S * 2/1917 Green D12/184
D50,346 S * 2/1917 Green D12/184
2,059,305 A 11/1936 Best
5,238,268 A 8/1993 Logan
5,340,154 A 8/1994 Scott
D382,239 S * 8/1997 Logan et al. D12/184
5,697,644 A 12/1997 Logan
D395,421 S * 6/1998 Gable et al. D12/407
5,829,786 A 11/1998 Dahl
D403,639 S * 1/1999 Gale et al. D12/184
5,879,045 A 3/1999 Logan
D424,495 S * 5/2000 Damon et al. D12/196
D424,496 S * 5/2000 Damon et al. D12/196
D431,511 S * 10/2000 Damon et al. D12/196
D432,476 S * 10/2000 Damon et al. D12/196
D436,335 S * 1/2001 Beigel D12/196
D482,992 S * 12/2003 Hattori et al. D12/184
D491,858 S * 6/2004 Velazco D12/196
D517,965 S * 3/2006 Metros et al. D12/190

(57) **CLAIM**

I claim the ornamental design for a vehicle fender flare, as shown and described.

DESCRIPTION

FIG. 1 is an isometric view of a vehicle fender flare showing the new design.

FIG. 2 is a side view of the new design.

FIG. 3 is a top view of the new design.

FIG. 4 is an isometric front view of the new design; and,

FIG. 5 is an isometric rear view of the new design.

The broken lines shown in the drawings represent unclaimed portions of the structure and form no part of the claimed design. Furthermore, the interior surfaces that are shown without surface shading form no part of the claimed design.

1 Claim, 3 Drawing Sheets

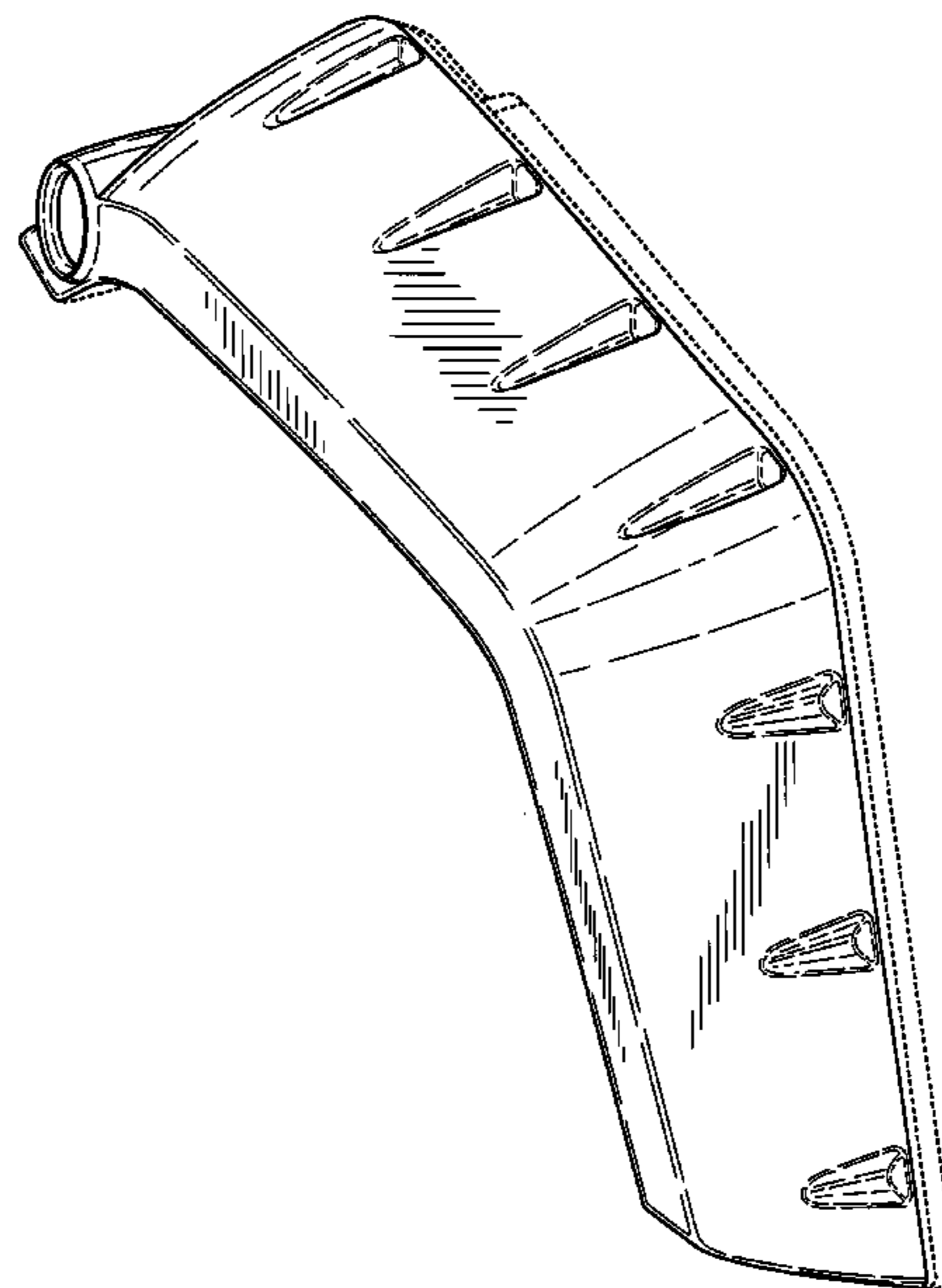
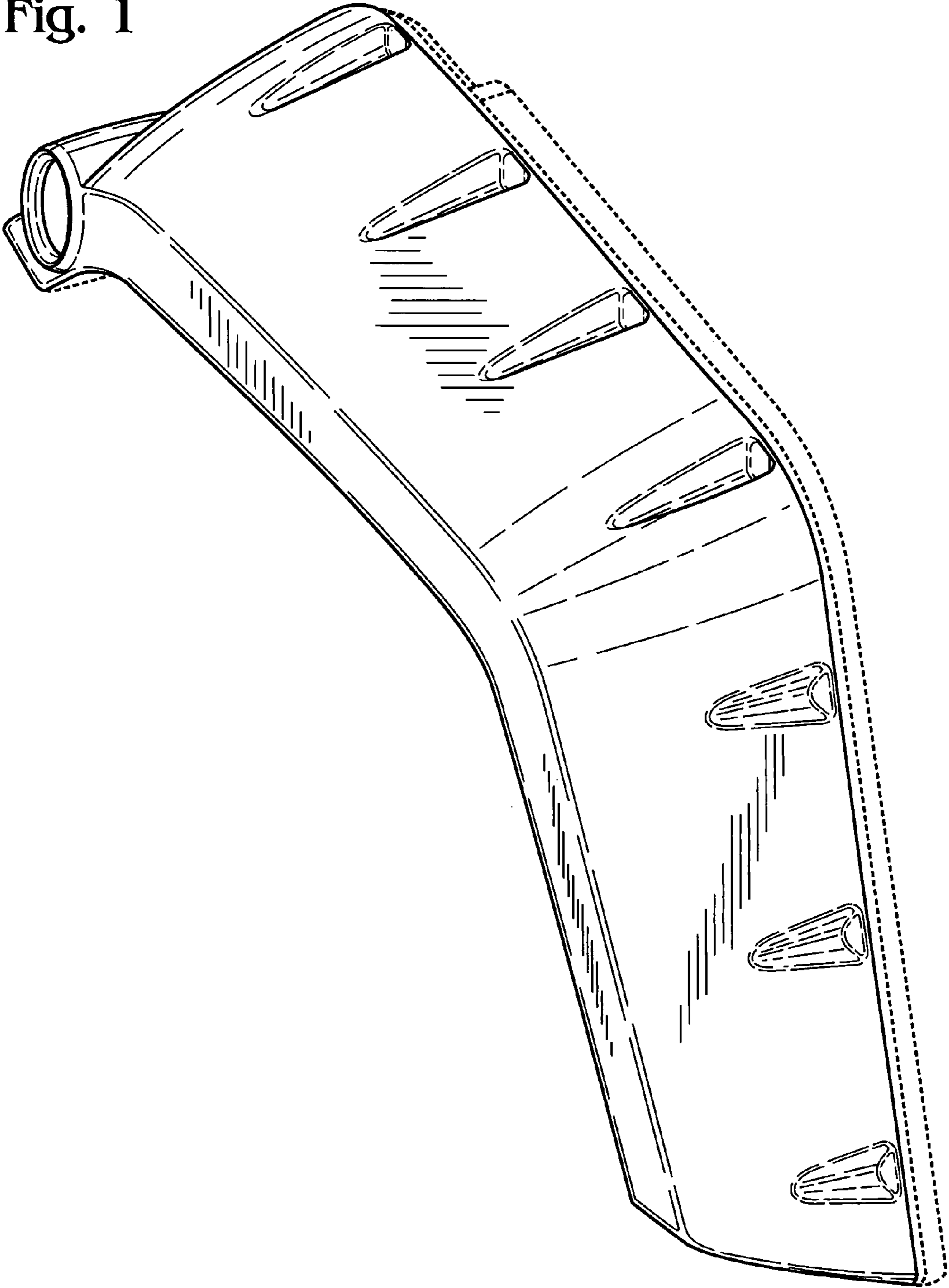

Fig. 1



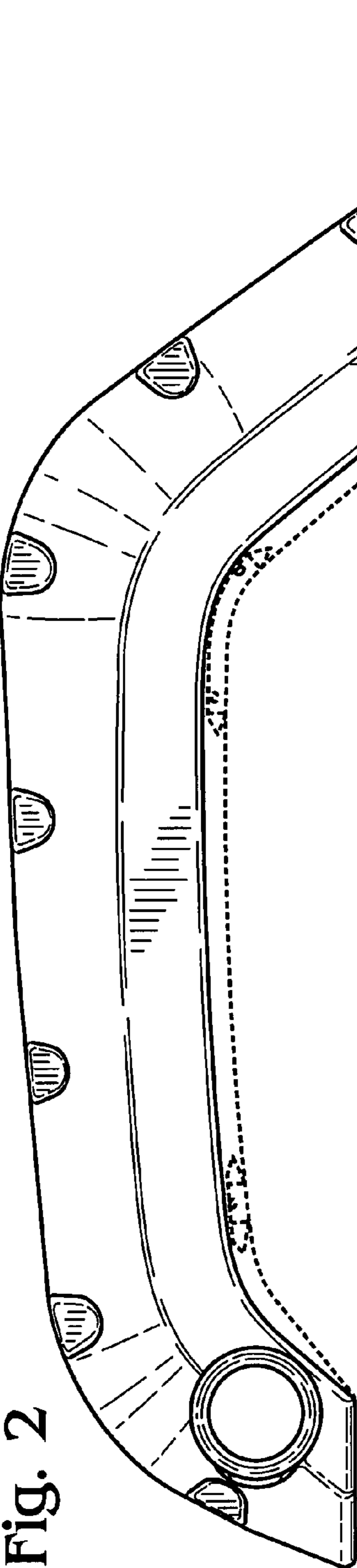

Fig. 2

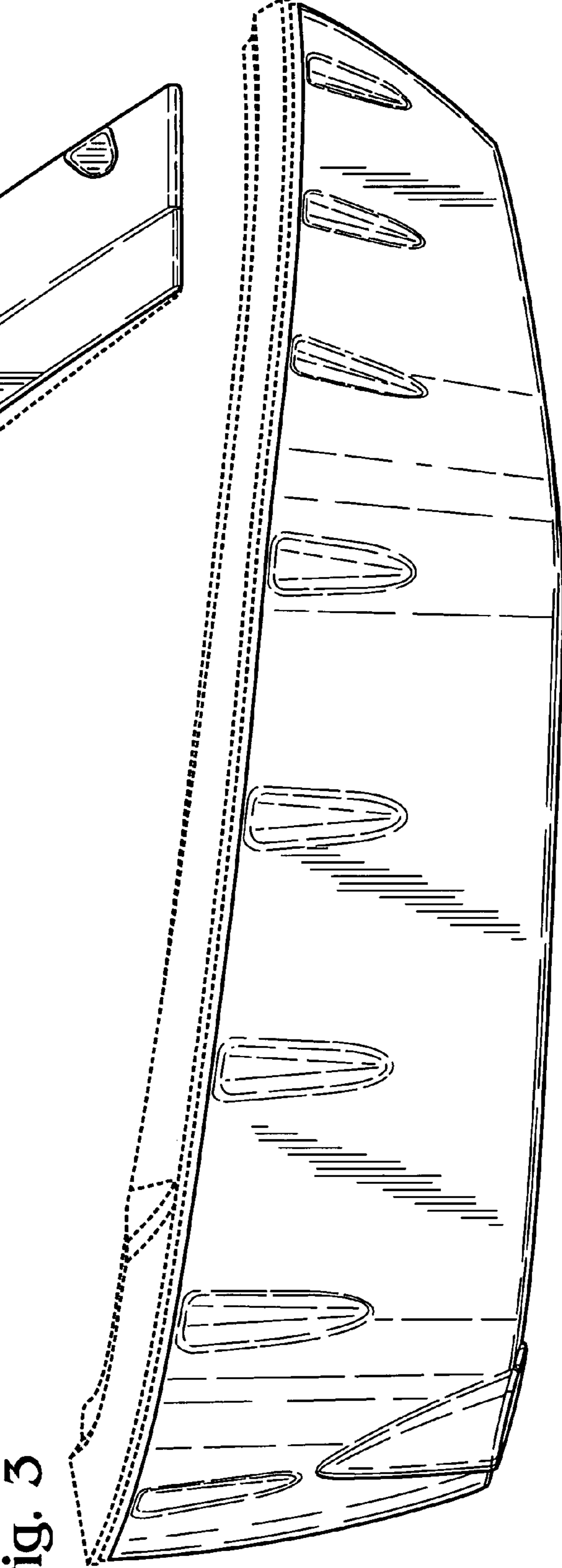

Fig. 3

Fig. 5

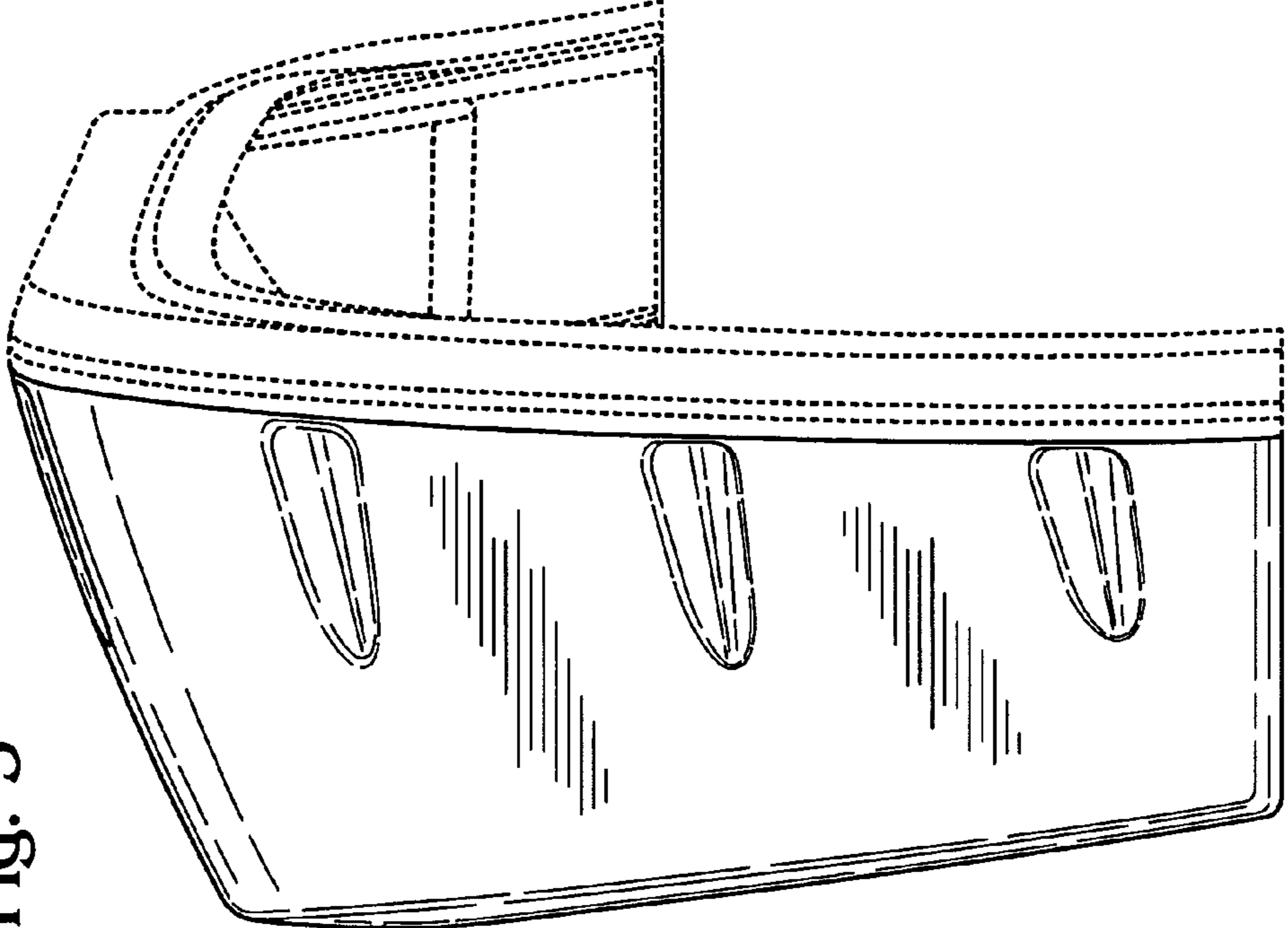

Fig. 4

