



US00D582710S

(12) **United States Design Patent**  
**Perlman**

(10) **Patent No.:** **US D582,710 S**  
(45) **Date of Patent:** **\*\* Dec. 16, 2008**

(54) **BATHROOM CADDY**

2006/0103089 A1 5/2006 Decoste

(76) Inventor: **Shmuel B. Perlman**, 3501 Pinkney Rd.,  
Baltimore, MD (US) 21215

(\*\*) Term: **14 Years**

(21) Appl. No.: **29/287,560**

(22) Filed: **Aug. 23, 2007**

(51) **LOC (8) Cl.** ..... **23-02**

(52) **U.S. Cl.** ..... **D6/525**

(58) **Field of Classification Search** ..... D6/515-525,  
D6/542, 546-550; 211/13.1, 87.01, 88.01,  
211/88.04; 206/389, 77.1; 242/570, 590;  
248/309.1

See application file for complete search history.

(56) **References Cited**

**U.S. PATENT DOCUMENTS**

4,098,486	A	7/1978	Hornsby	
4,602,759	A	7/1986	Webber	
4,825,779	A	5/1989	Simms	
D358,052	S	5/1995	Carpenter	
5,438,938	A	8/1995	Meeker et al.	
D368,819	S	4/1996	Lemmons	
5,526,943	A	6/1996	Thompson	
5,603,267	A	2/1997	Soper	
5,621,927	A	4/1997	Reiss et al.	
5,761,753	A	6/1998	Talbert	
D403,906	S *	1/1999	Gotti	D6/524
5,878,893	A	3/1999	Micienko	
D418,997	S	1/2000	Leveen et al.	
6,032,586	A	3/2000	Reyes	
D441,507	S *	5/2001	Gholston et al.	D6/524
D447,900	S *	9/2001	Wright	D6/525
D448,225	S	9/2001	Wright	
6,308,641	B1	10/2001	Kingbury	
D458,492	S *	6/2002	Ho	D6/525
D471,045	S *	3/2003	Cheng	D6/525
6,983,493	B1	1/2006	Shaumyan	
D545,099	S *	6/2007	Fernandez, Jr.	D6/524

**OTHER PUBLICATIONS**

U.S. Appl. No. 12/076,880, filed Mar. 25, 2008.  
Wisconsin Innovation Service Center Report with attachments dated  
Sep. 11, 2006 (53 pages, including: letter (1 pg); Report (9 pgs);  
BookHolder.com Read with Ease (5 pgs); Table-Mate II (1 pg);  
Stacks and Stacks (2 pgs); Levenger (4 pgs); Vintage Tub & Bath (1  
pg); The Bed Tray Shoppe (5 pgs); Tones for the throne  
Bathroom . . . , The Denver Post dated Jun. 1, 2006 (3 pgs); Spa Finder  
Announces Top Spa Trends to Watch in 2006, Market Wire dated  
Dec. 8, 2005 (4 pgs); Taking Small Steps Forward A Mature Industry  
Experienced Less Than 2 Percent Overall Growth, Business and  
Industry, HFN, dated Feb. 28, 2005 (10 pgs); On the Rebound www.  
kbbonline.com dated Jan. 2006 (4 pgs); Kitchen & Bath Business,  
dated Jan. 1, 2006 (3 pgs); Kitchen & Bath Business, dated Apr. 1,  
2006 (1 pg)).

\* cited by examiner

*Primary Examiner*—Brian N Vinson

(74) *Attorney, Agent, or Firm*—Dinesh Agarwal, P.C.

(57) **CLAIM**

The ornamental design for a bathroom caddy, as shown and  
described.

**DESCRIPTION**

FIG. 1 is a perspective view of a bathroom caddy showing my  
new design;  
FIG. 2 is a right side view of the bathroom caddy of FIG. 1;  
FIG. 3 is a left side view of the bathroom caddy of FIG. 1;  
FIG. 4 is a rear elevational view of the bathroom caddy of  
FIG. 1;  
FIG. 5 is a front elevational view of the bathroom caddy of  
FIG. 1;  
FIG. 6 is a top plan view of the bathroom caddy of FIG. 1; and,  
FIG. 7 is a bottom plan view of the bathroom caddy of FIG. 1.  
The matter shown in phantom lines in FIG. 1 is for illustrative  
purposes only and forms no part of the claimed design.

**1 Claim, 7 Drawing Sheets**

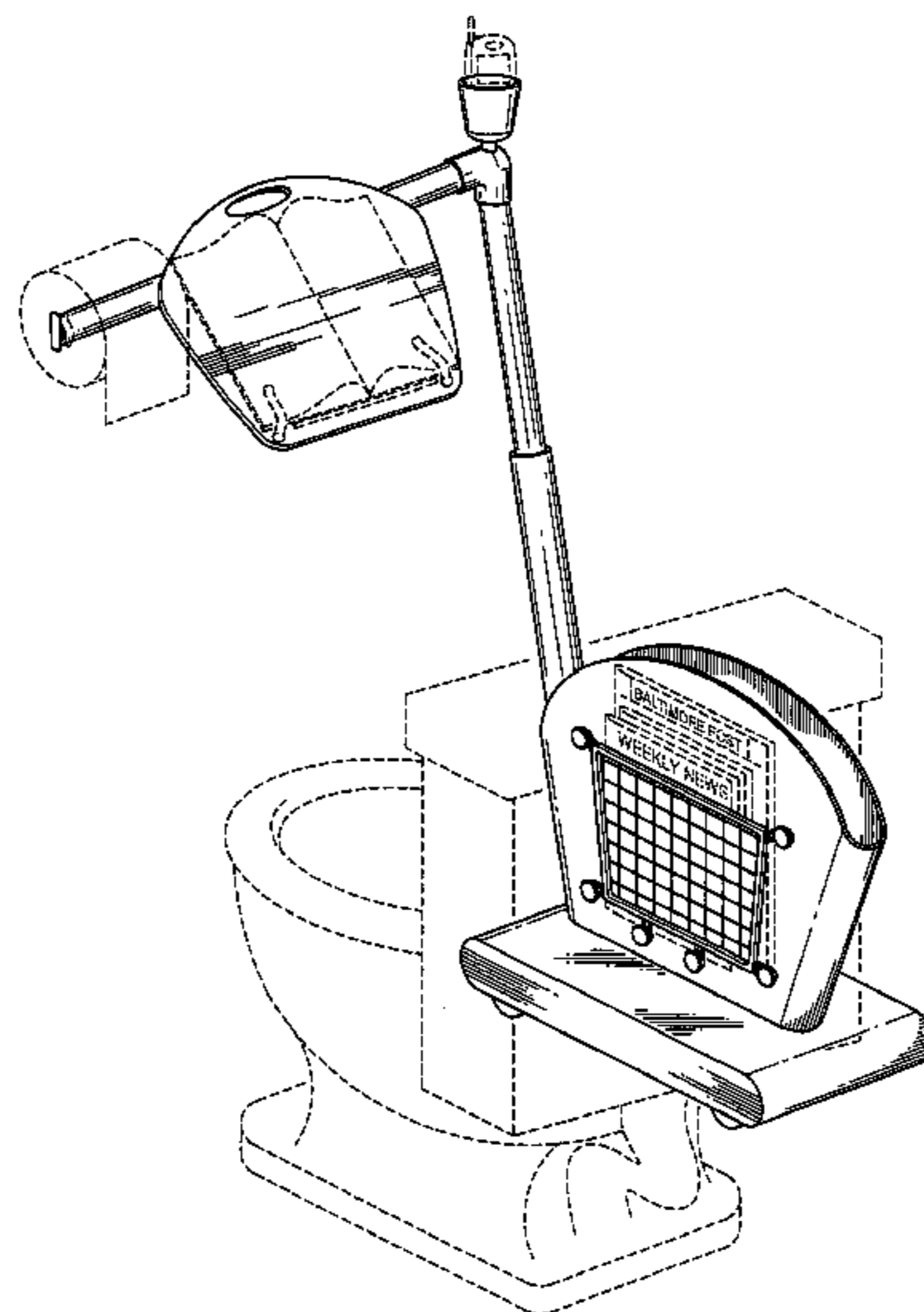

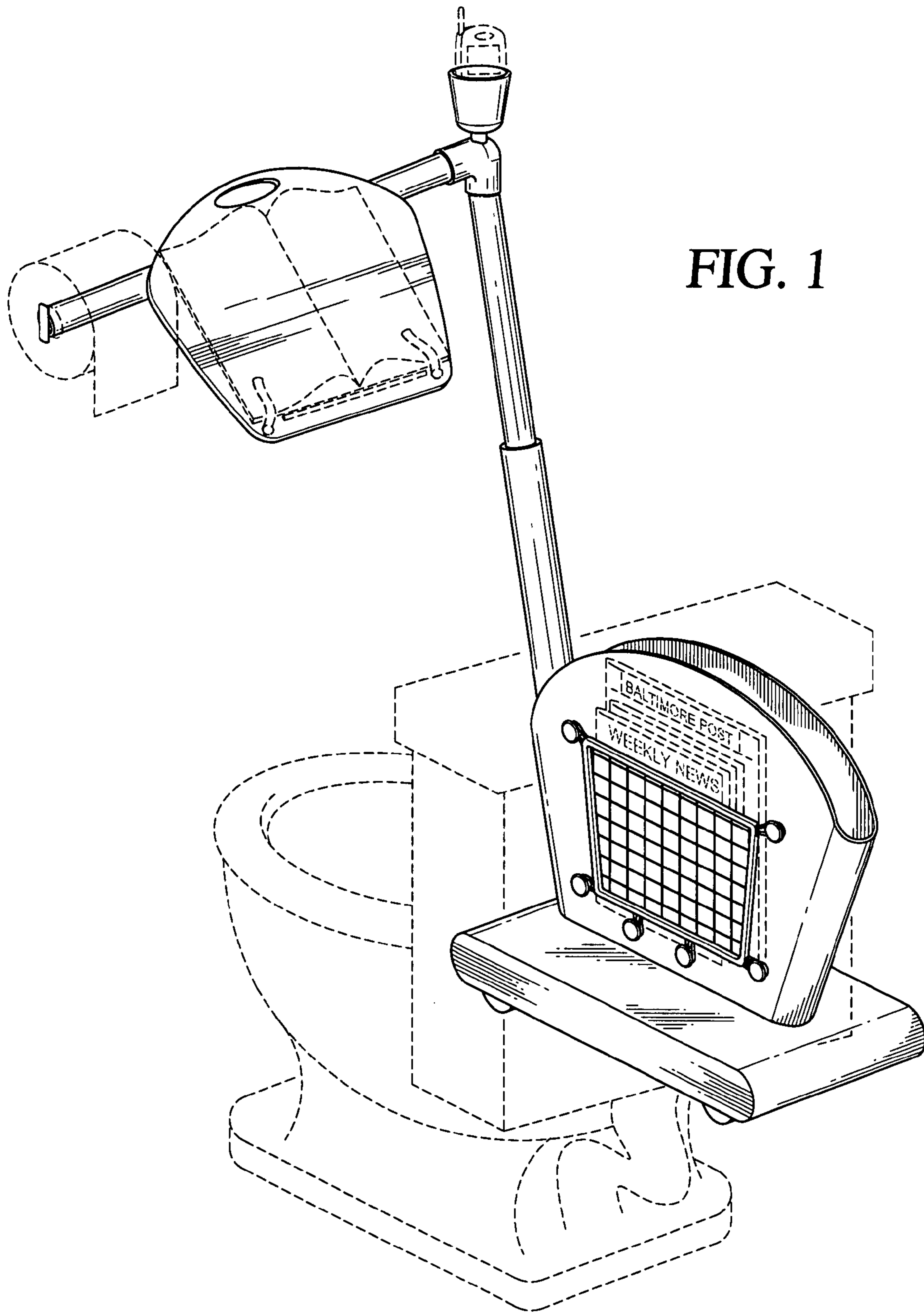

FIG. 1

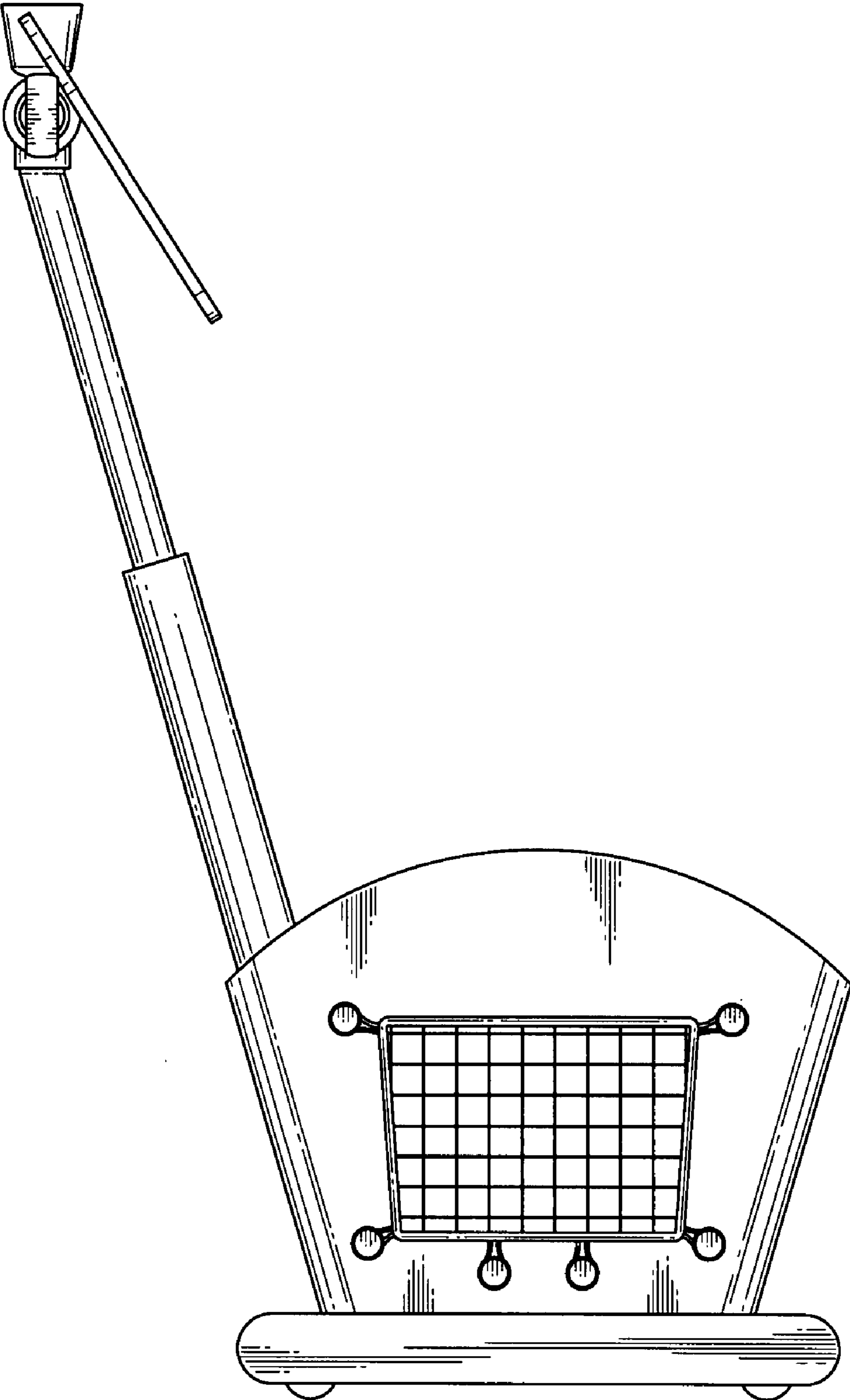

FIG. 2

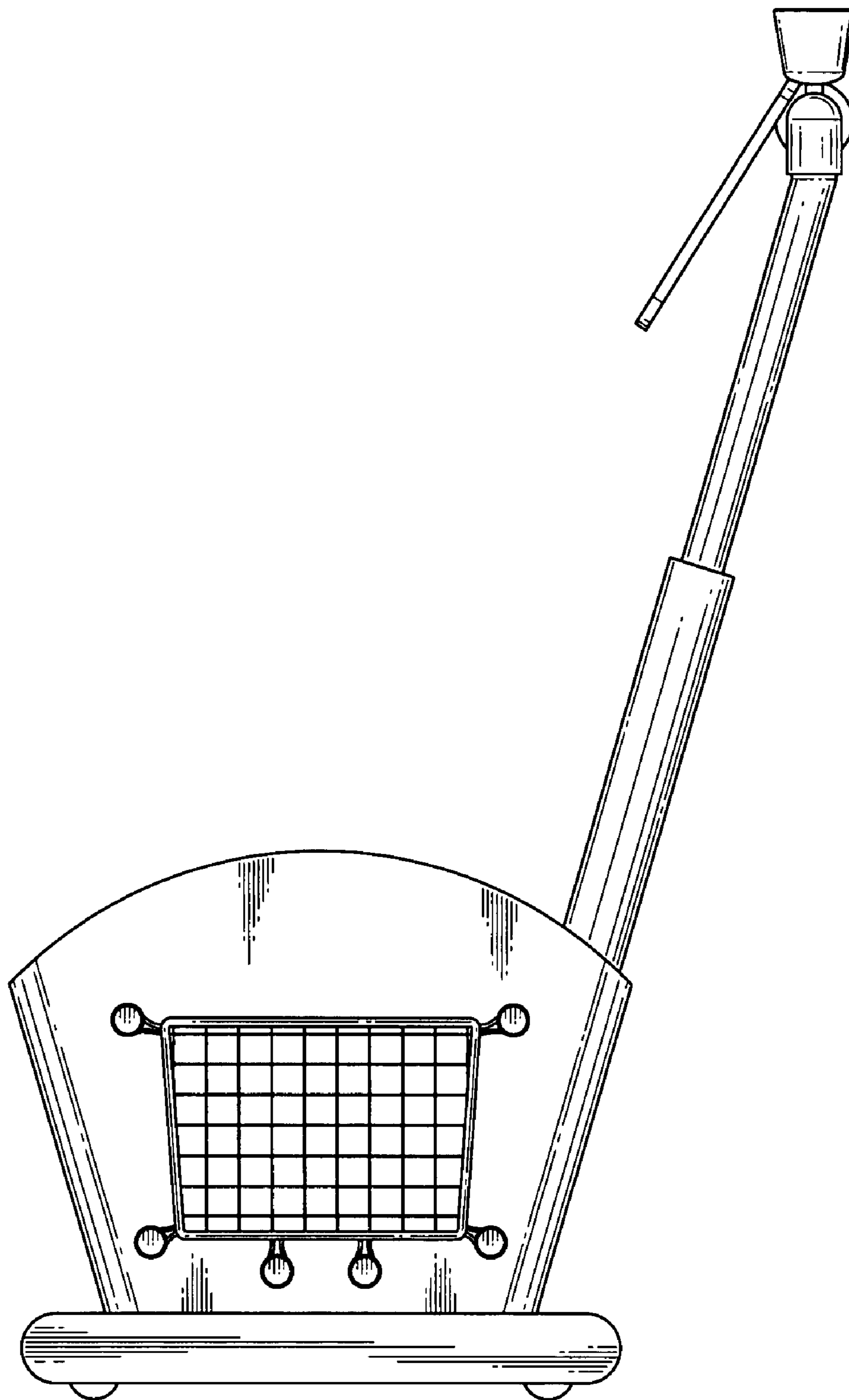

FIG. 3

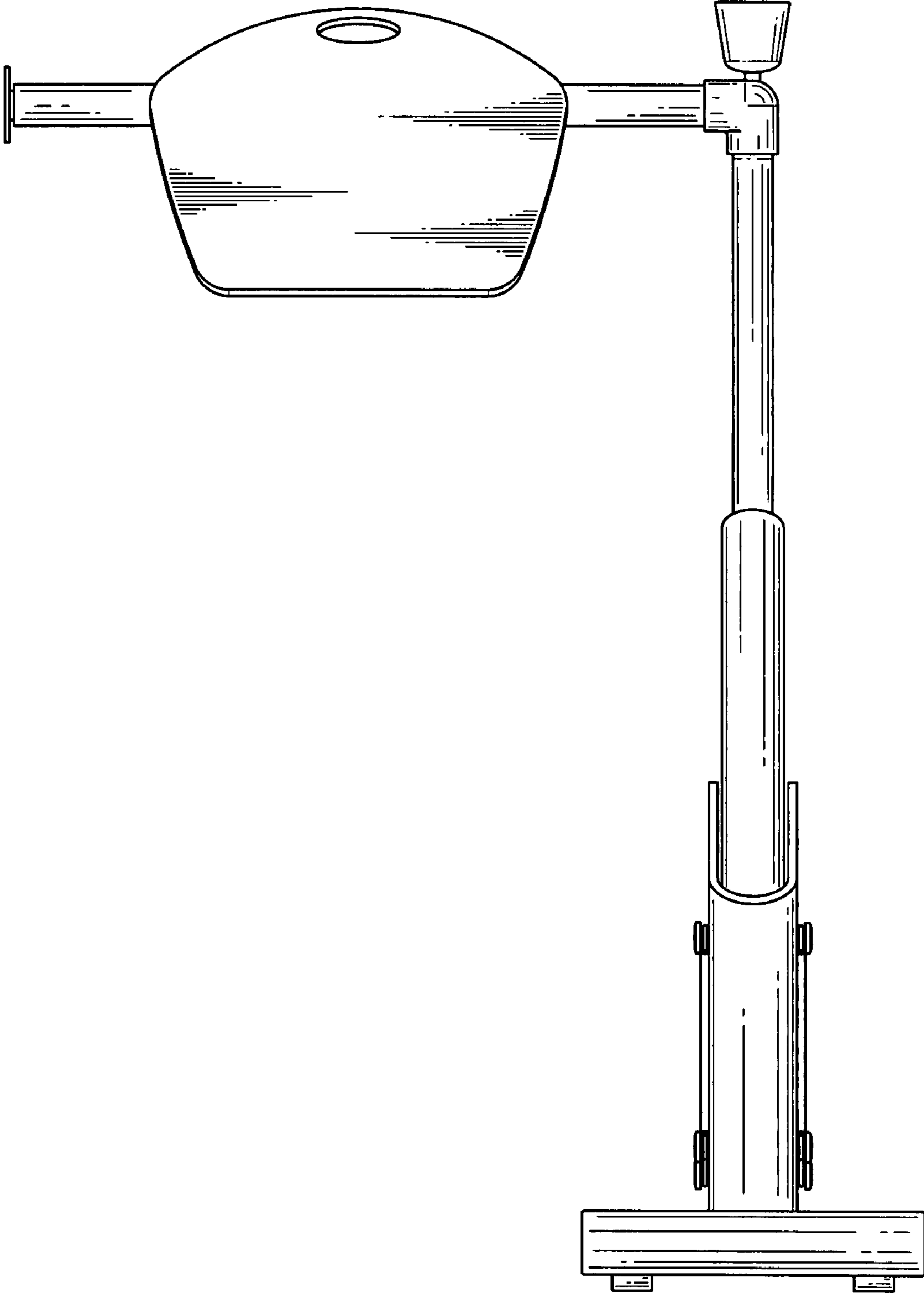

FIG. 4

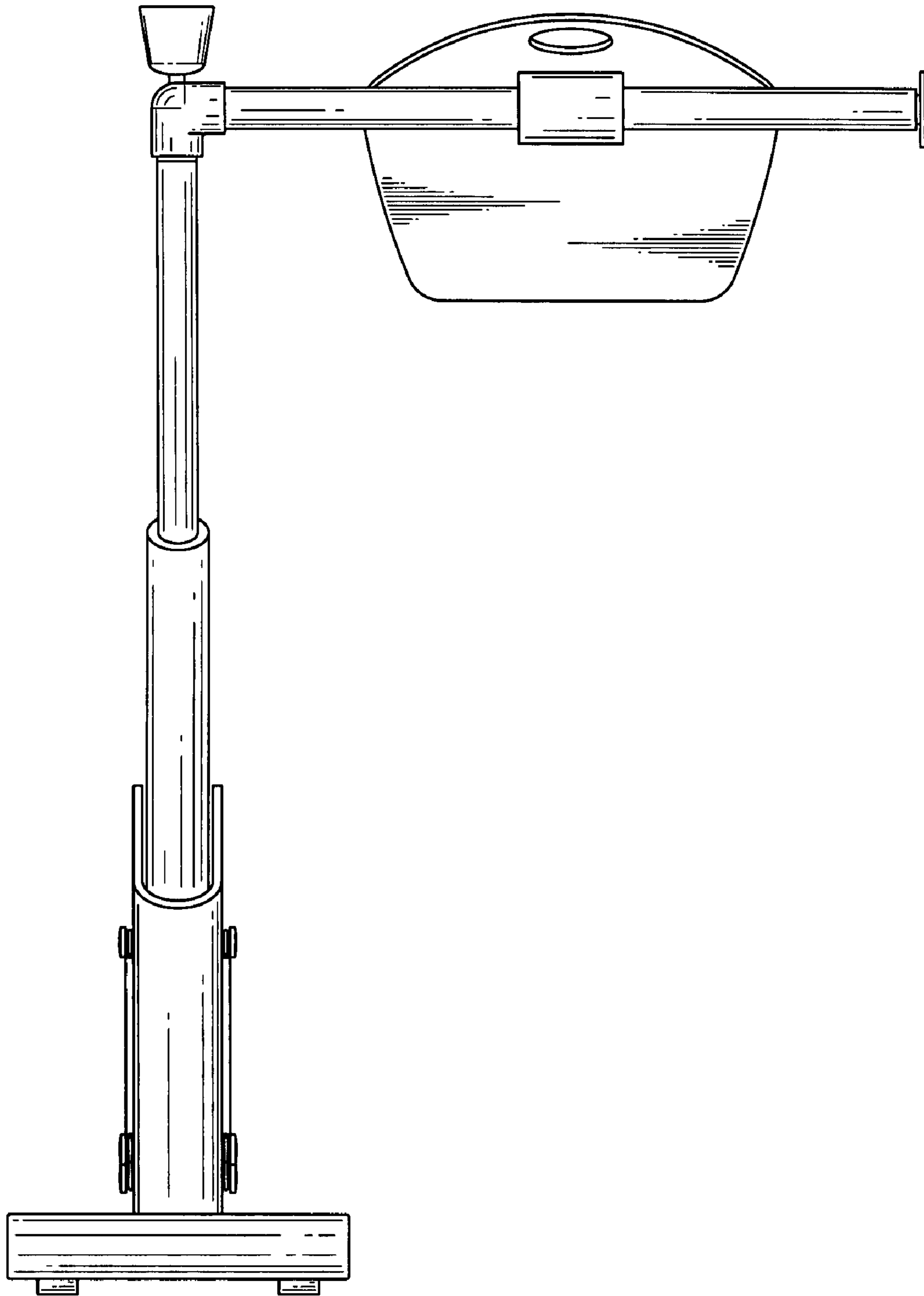

FIG. 5

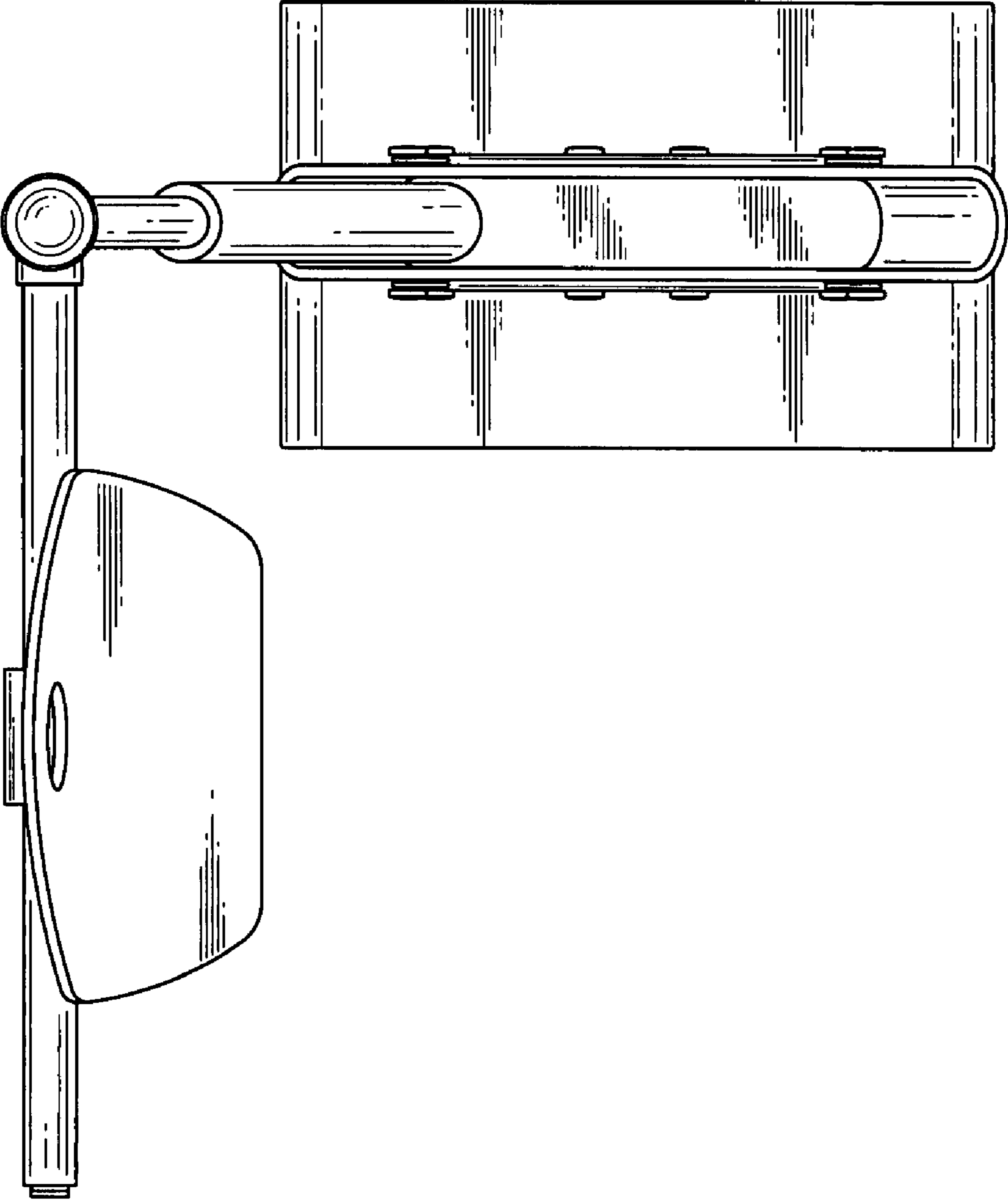

FIG. 6

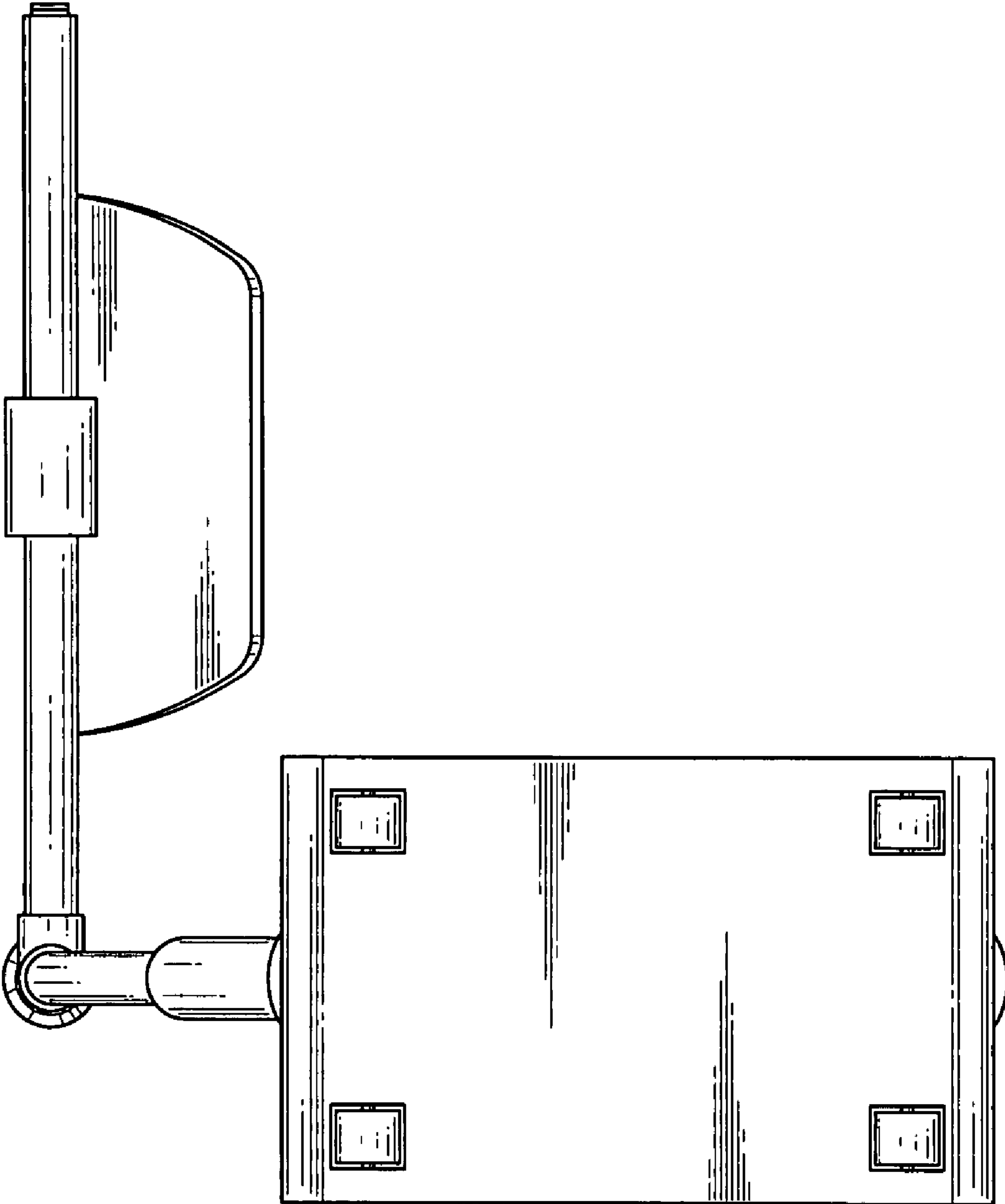

FIG. 7