



US00D582491S

(12) **United States Design Patent**
Sondors

(10) **Patent No.:** **US D582,491 S**
(45) **Date of Patent:** **** Dec. 9, 2008**

(54) **TOY HELICOPTER**

(75) Inventor: **Ivars Sondors**, Chicago, IL (US)

(73) Assignee: **Manberg Ltd.**, Hong Kong (HK)

(**) Term: **14 Years**

(21) Appl. No.: **29/319,150**

(22) Filed: **Jun. 4, 2008**

(51) **LOC (8) Cl.** **21-01**

(52) **U.S. Cl.** **D21/442**

(58) **Field of Classification Search** D21/436-454;
D12/319-345; 446/30-68; 244/17.11-17.27
See application file for complete search history.

(56) **References Cited**

U.S. PATENT DOCUMENTS

2,384,516	A	9/1945	Young	
D147,513	S	9/1947	Stout	
2,487,020	A	11/1949	Gilcrease	
D188,145	S	* 6/1960	Jones D12/327
3,279,096	A	* 10/1966	Emigh 434/33
3,325,122	A	* 6/1967	Young, Jr. 244/17.13
D211,377	S	6/1968	Lakin	
3,528,633	A	* 9/1970	Knemeyer 244/179
D253,003	S	9/1979	Tanaka	
4,272,041	A	6/1981	Mabuchi et al.	
D318,499	S	* 7/1991	Rankin D21/438
5,252,100	A	* 10/1993	Osawa et al. 446/44
5,609,312	A	3/1997	Arlton	
5,628,620	A	5/1997	Arlton	
5,836,545	A	* 11/1998	Arlton et al. 244/60
D406,810	S	* 3/1999	Lai D12/327
5,906,476	A	5/1999	Arlton	
D503,198	S	* 3/2005	Rehkemper et al. D21/442
7,178,758	B2	* 2/2007	Rehkemper 244/17.11
D544,825	S	6/2007	Van de Rostyne et al.	
D545,755	S	7/2007	Van de Rostyne et al.	
D546,269	S	7/2007	Van de Rostyne et al.	
D552,531	S	10/2007	Van de Rostyne et al.	

D554,040	S	10/2007	Van de Rostyne et al.	
D559,764	S	1/2008	Wai	
D561,676	S	2/2008	Wai	
D561,677	S	2/2008	Wal	
D561,678	S	2/2008	Wai	
2006/0231677	A1	* 10/2006	Zimet et al. 244/17.23
2007/0164148	A1	7/2007	Van De Rostyne	
2007/0164149	A1	7/2007	Van De Rostyne	
2007/0164150	A1	7/2007	Van De Rostyne	
2007/0181742	A1	8/2007	Van De Rostyne	
2007/0221781	A1	9/2007	Van De Rostyne	
2007/0272794	A1	11/2007	Van De Rostyne	
2008/0076319	A1	3/2008	Van De Rostyne	
2008/0076320	A1	3/2008	Van De Rostyne	
2008/0085653	A1	4/2008	Van De Rostyne	

FOREIGN PATENT DOCUMENTS

EM	000733894-0001	*	7/2007
EM	000910872-0001	*	5/2008

* cited by examiner

Primary Examiner—Catherine Tuttle
(74) *Attorney, Agent, or Firm*—Cardinal Law Group; Ronald E. Andermann

(57) **CLAIM**

The ornamental design for a toy helicopter, as shown and described.

DESCRIPTION

FIG. 1 is a left side elevation view of the toy helicopter showing my new design;

FIG. 2 is a right side elevational view thereof;

FIG. 3 is a top, rear and right side perspective view thereof; and,

FIG. 4 is a top, front and left side perspective view thereof.

The broken lines are included for the purpose of illustrating portions of the toy helicopter that form no part of the claimed design.

1 Claim, 4 Drawing Sheets

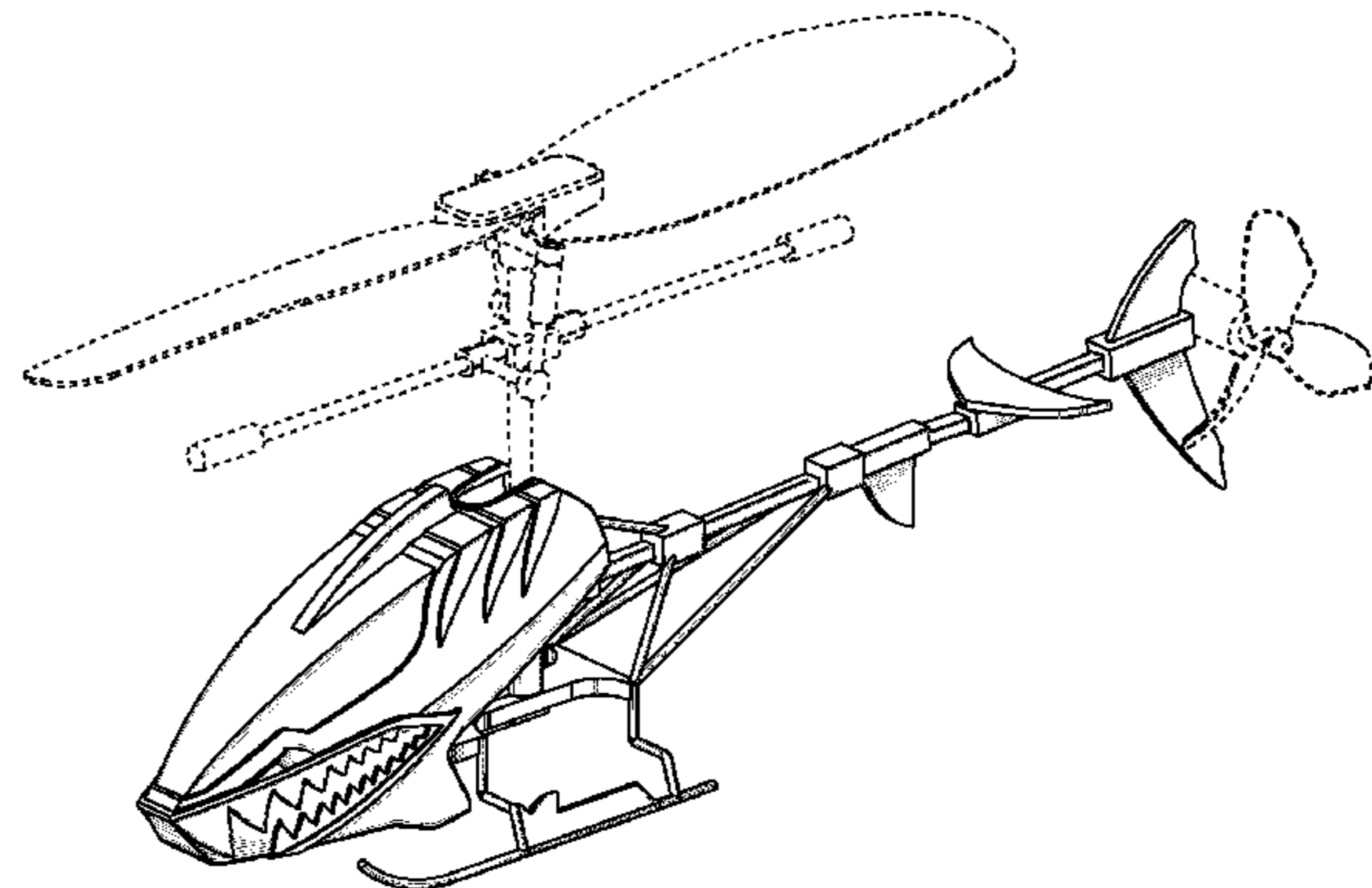
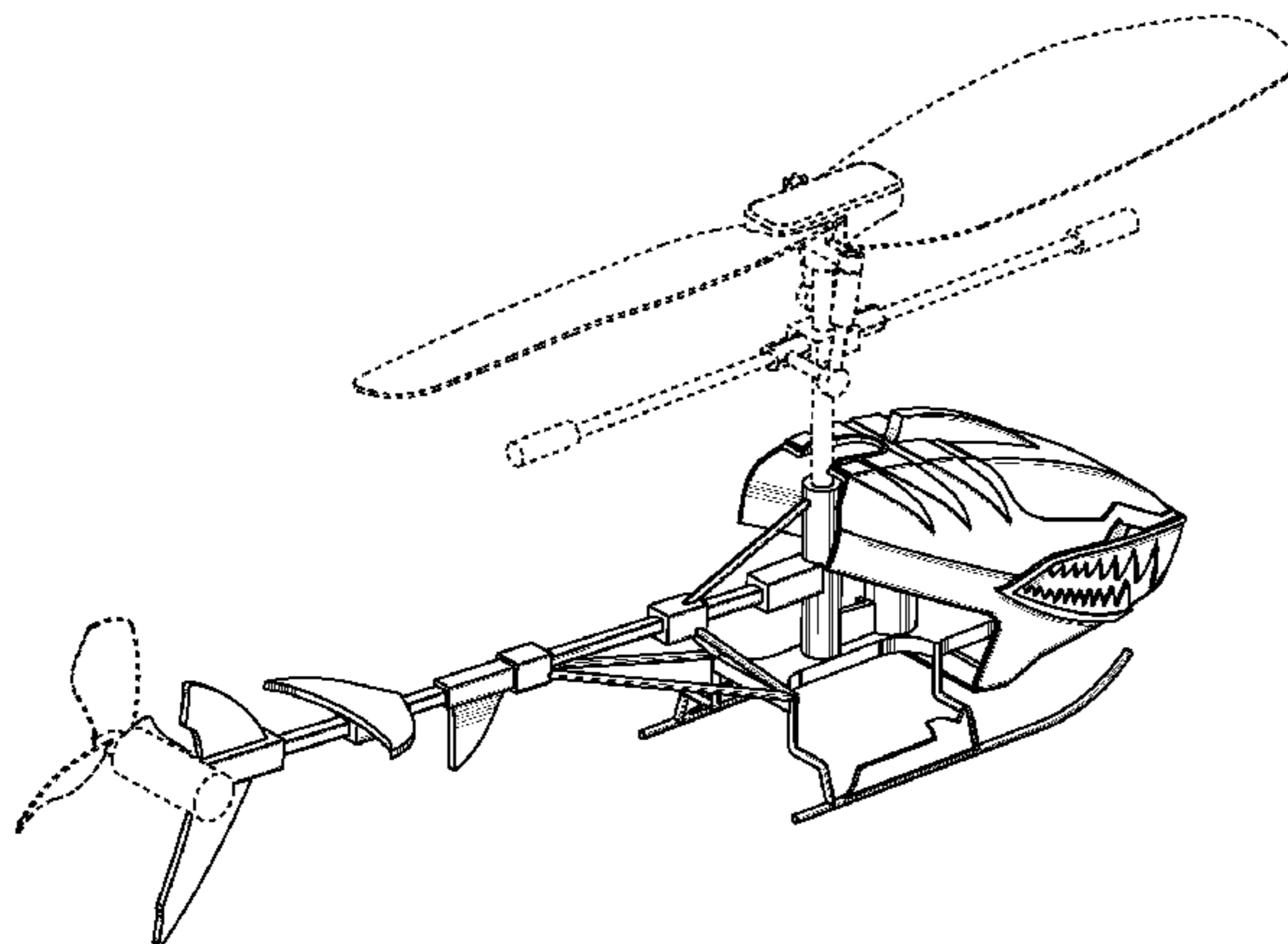

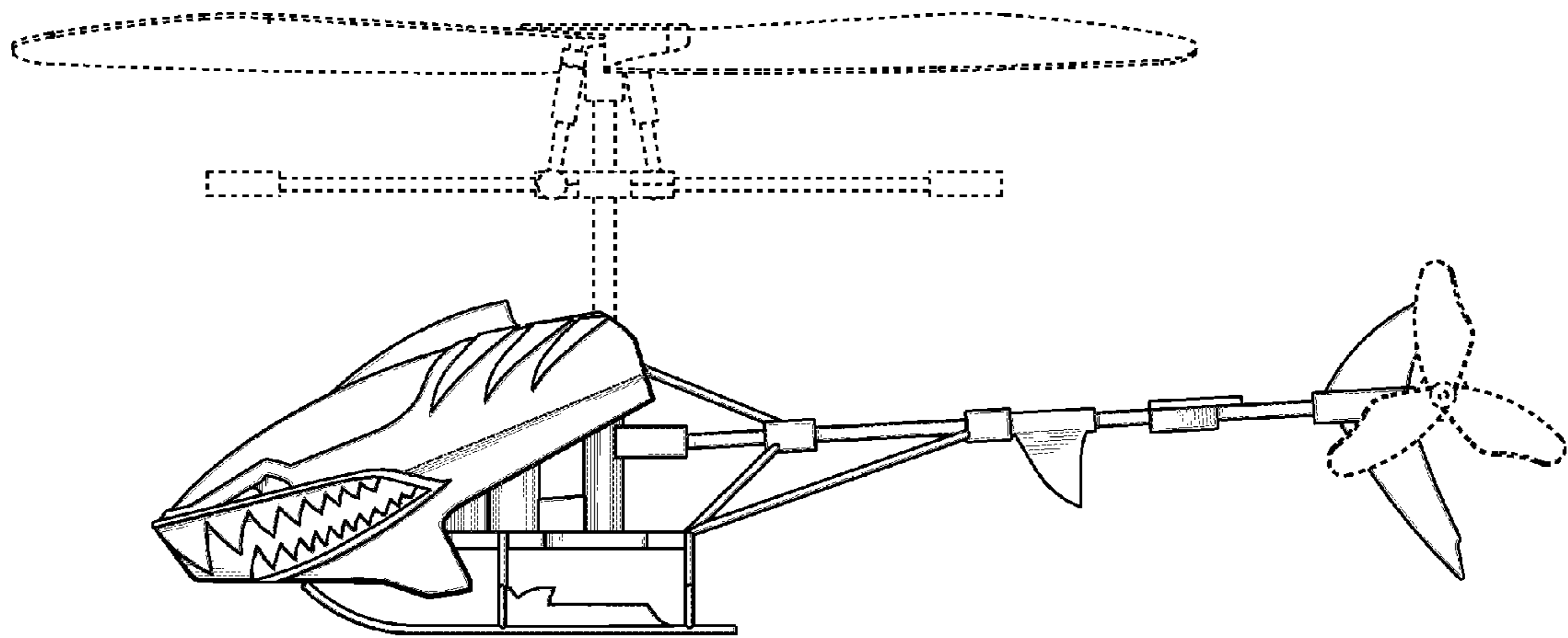

FIG. 1

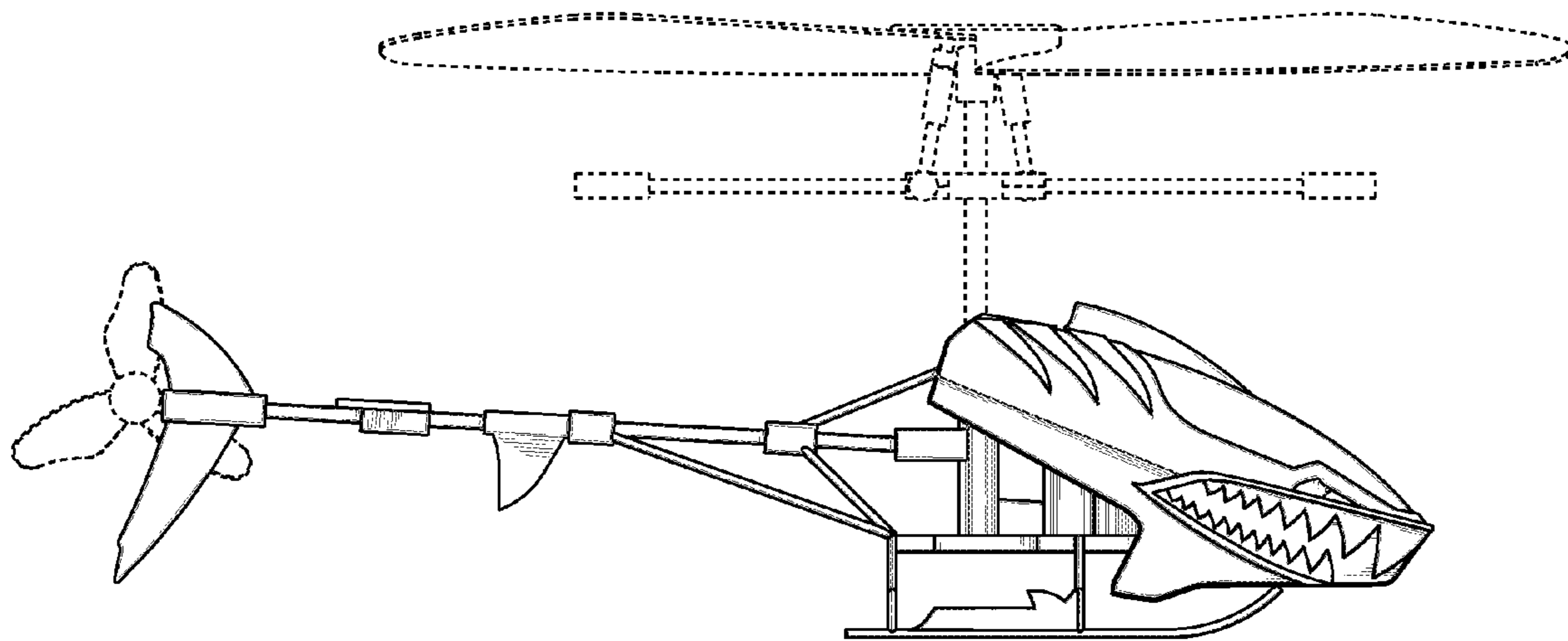

FIG. 2

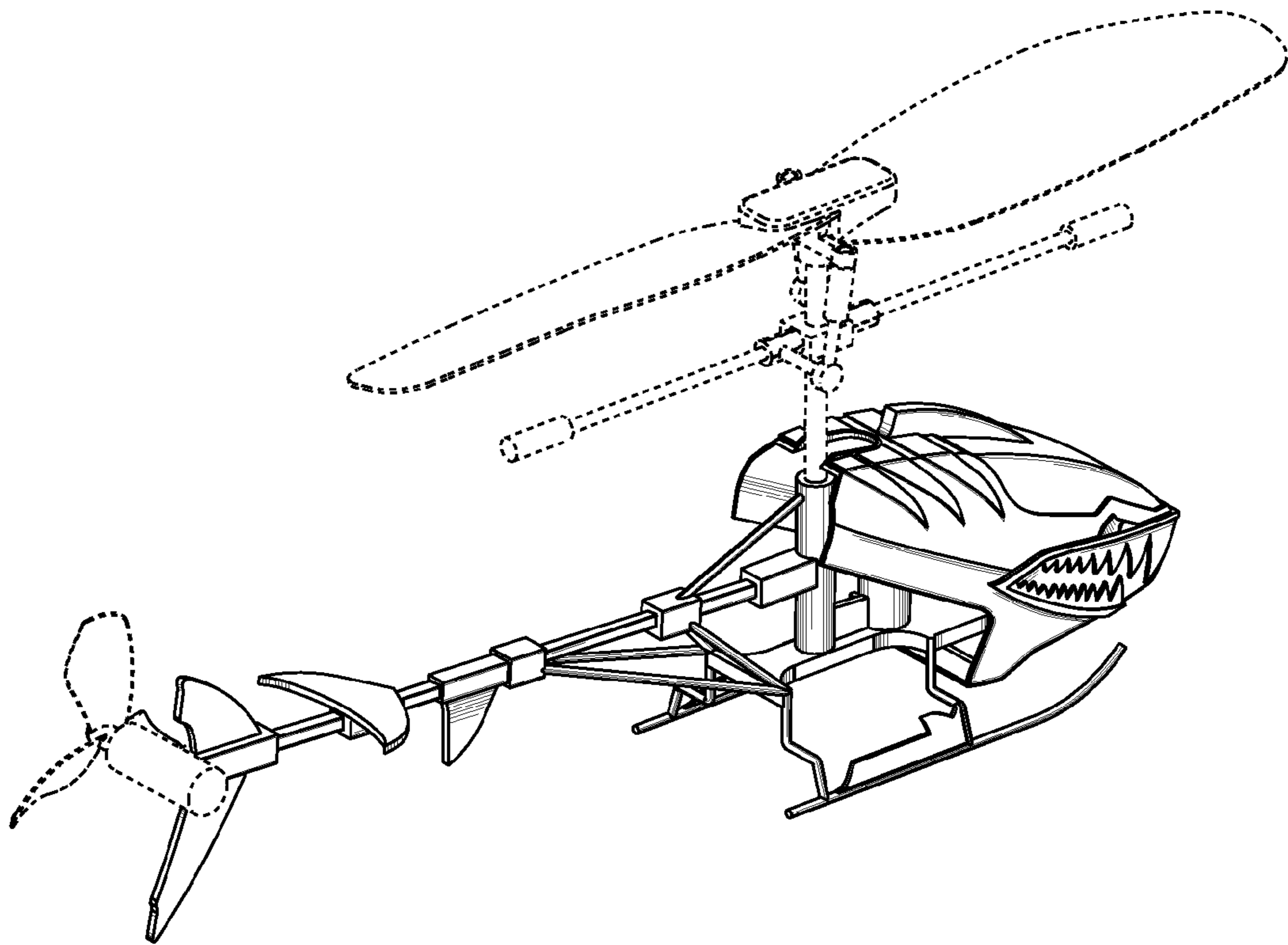

FIG. 3

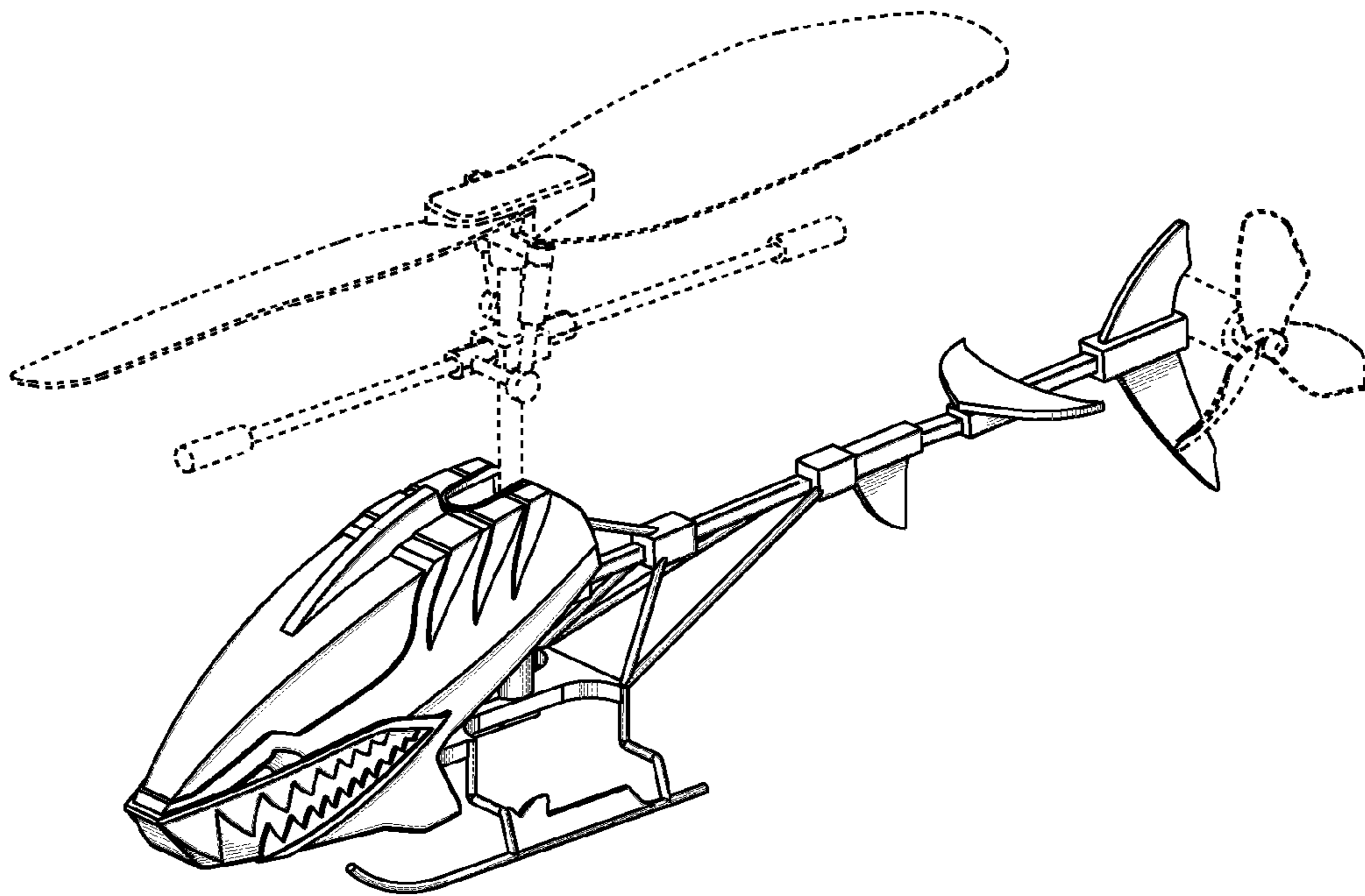

FIG. 4