



US00D582469S

(12) **United States Design Patent**
Jones et al.

(10) **Patent No.:** **US D582,469 S**
(45) **Date of Patent:** **** Dec. 9, 2008**

(54) **HAND-HELD SHREDDER FOR PAPER OR THE LIKE**

(75) Inventors: **Braden L. Jones**, Phoenix, AZ (US);
Chris Holman, Mesa, AZ (US)

(73) Assignee: **Esselte Corporation**, Melville, NY (US)

(**) Term: **14 Years**

(21) Appl. No.: **29/300,287**

(22) Filed: **Mar. 10, 2008**

(51) **LOC (8) Cl.** **18-04**

(52) **U.S. Cl.** **D18/34.4**

(58) **Field of Classification Search** D18/34.1-34.9;
241/100, 236, 101.78, 36; 83/613, 614, 623,
83/485, 57-68; 164/468; 30/294, 296.1,
30/275.4, 276; D23/359

See application file for complete search history.

(56) **References Cited**

U.S. PATENT DOCUMENTS

3,304 A	10/1843	Sanford	
12,683 A	4/1855	Lackey	
250,732 A	12/1881	Hemje	
1,090,914 A	3/1914	Guettler	
3,620,461 A	11/1971	Pelleschi et al.	
3,883,953 A	5/1975	Saullo et al.	
4,980,942 A	1/1991	Spargo, Sr.	
5,036,590 A	8/1991	Reinke et al.	
D320,228 S *	9/1991	Isomoto et al.	D18/34.1
5,054,695 A	10/1991	Koornhof	
D362,866 S	10/1995	Johansson	
D412,716 S *	8/1999	Kroger	D18/34.5
D444,809 S *	7/2001	Chang	D18/34.4
D474,231 S *	5/2003	Lammers et al.	D18/34.4

D481,416 S *	10/2003	Chang	D18/34.4
D511,770 S *	11/2005	Chung	D14/240
D535,322 S *	1/2007	Lo	D18/34.4
7,156,330 B1 *	1/2007	Lo	241/36
D541,842 S *	5/2007	Sezaki	D18/34.5
D544,526 S *	6/2007	Shuhui et al.	D18/34.5
D550,278 S *	9/2007	Farneti	D18/34.1

FOREIGN PATENT DOCUMENTS

DE	19519049 A1	11/1996
EP	0413969	2/1991
WO	WO 9425166	11/1994

* cited by examiner

Primary Examiner—Charles A Rademaker

(74) *Attorney, Agent, or Firm*—Venable LLP; Henry J. Daley

(57) **CLAIM**

The ornamental design for a hand-held shredder for paper or the like, as shown and described.

DESCRIPTION

FIG. 1 is a perspective view of a hand-held shredder for paper or the like showing our new design;

FIG. 2 is a top plan view thereof;

FIG. 3 is a bottom plan thereof;

FIG. 4 is a front elevation thereof;

FIG. 5 is a rear elevation thereof;

FIG. 6 is a right side elevation thereof; and,

FIG. 7 is a left side elevation thereof.

The broken lines shown in the drawing represent environmental structure and form no part of the claimed design.

1 Claim, 4 Drawing Sheets

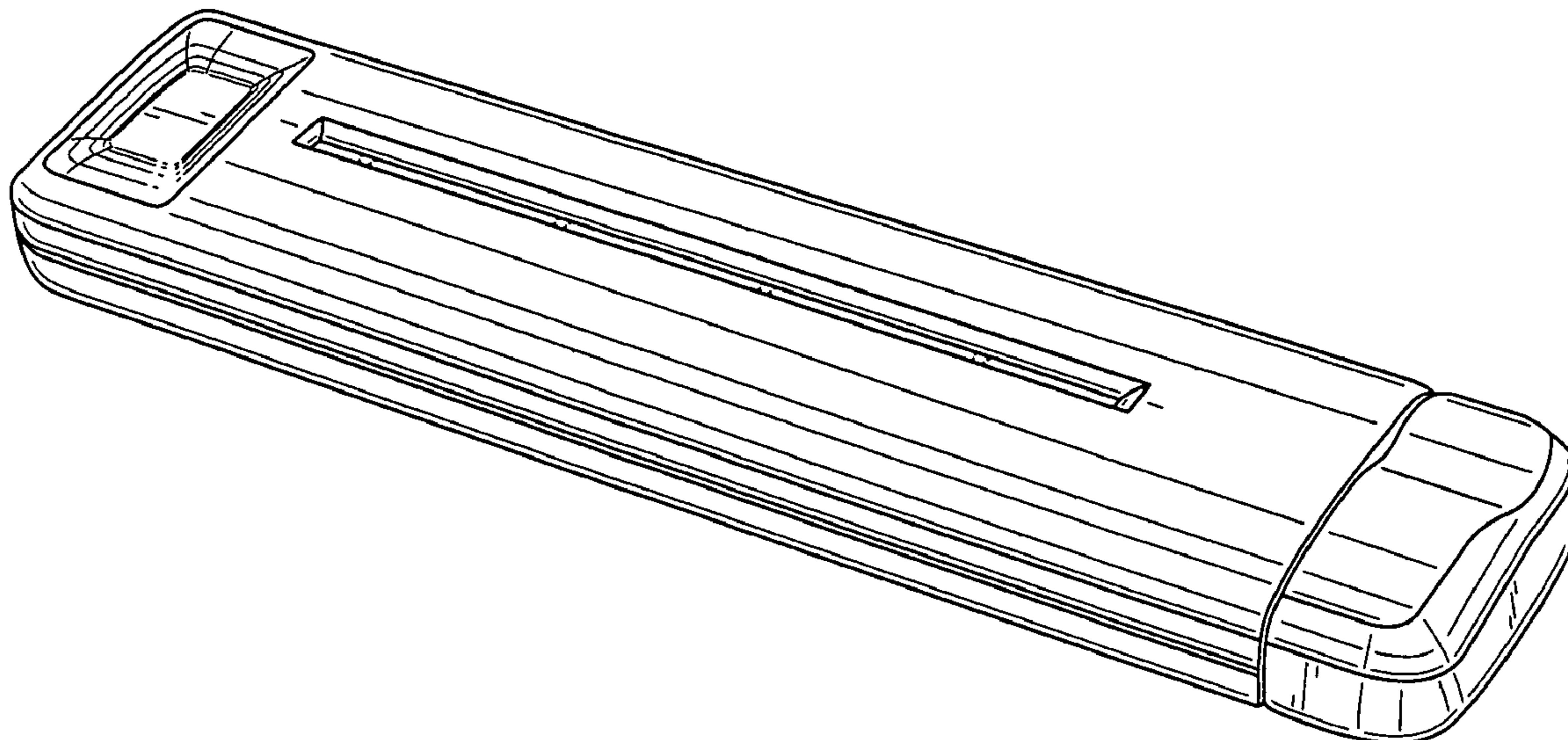

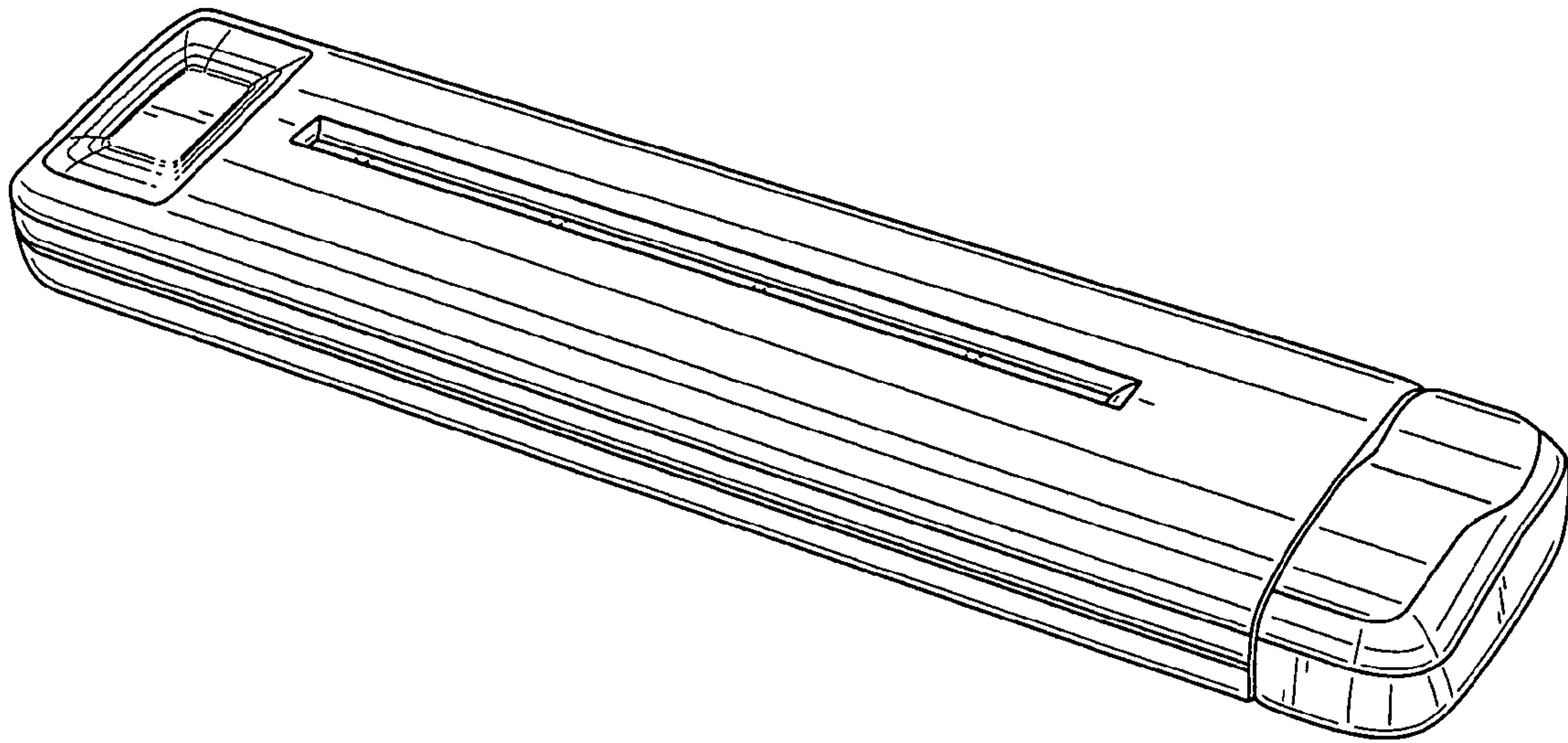

FIG. 1

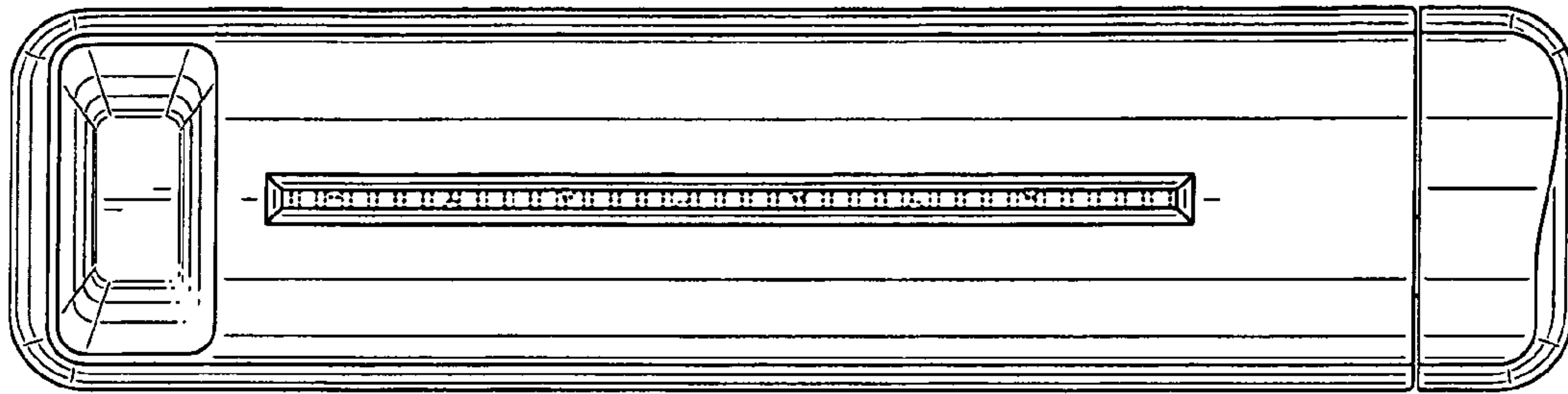

FIG. 2

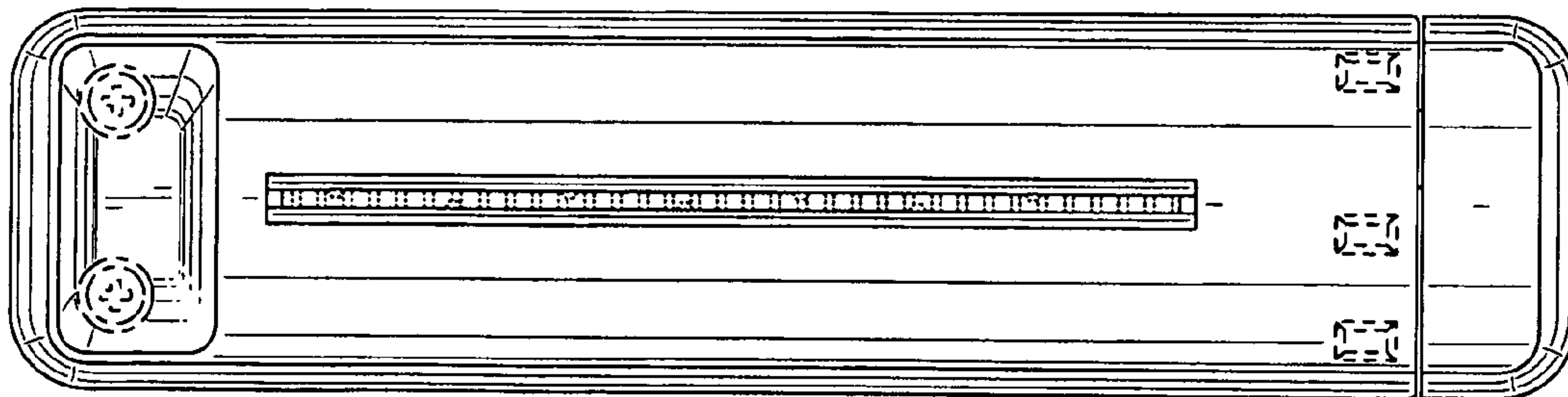

FIG. 3

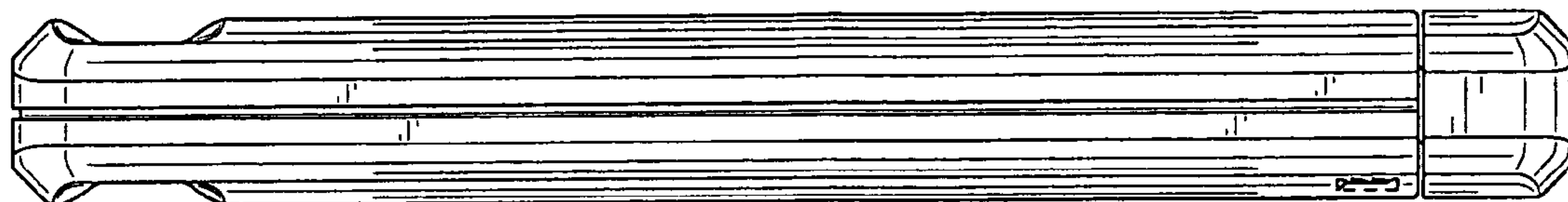

FIG. 4

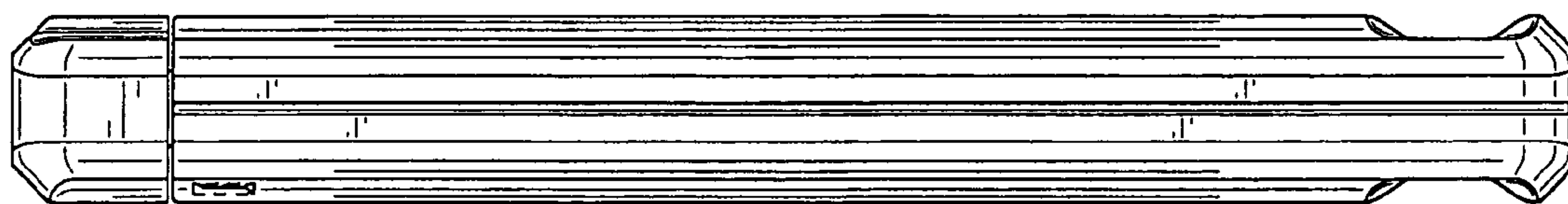

FIG. 5

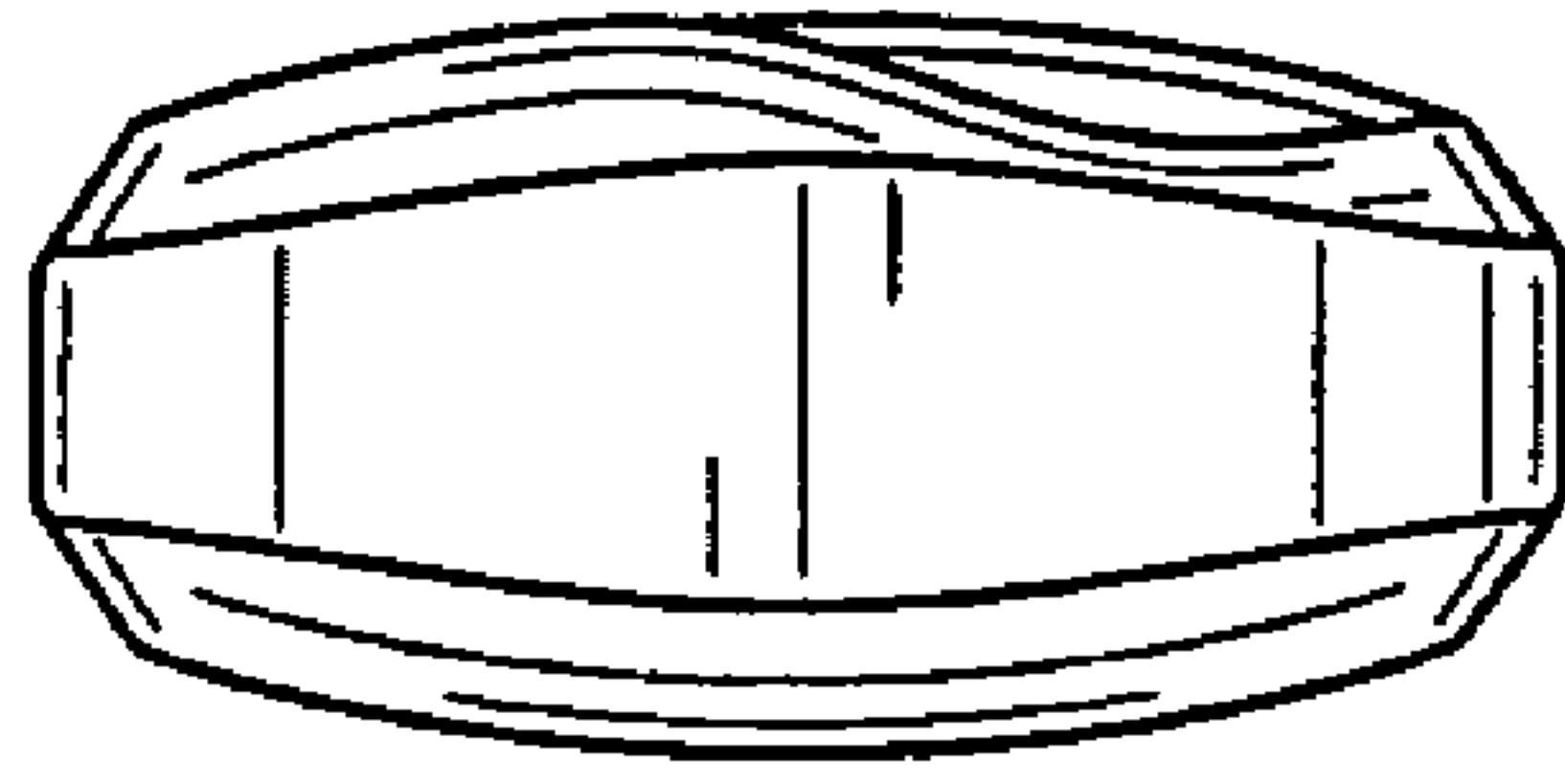

FIG. 6

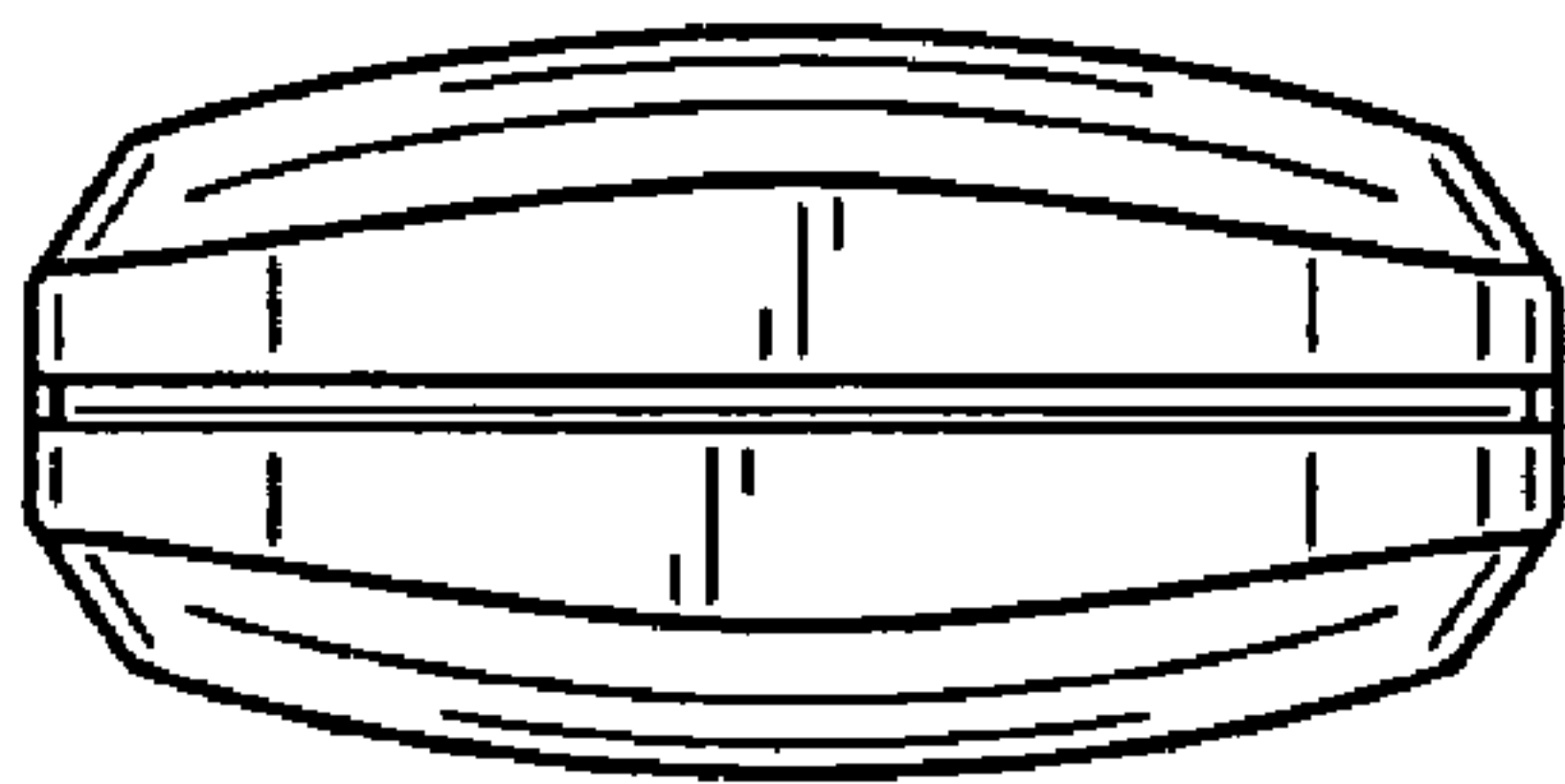

FIG. 7