



US00D582332S

(12) **United States Design Patent**
Rak

(10) **Patent No.:** **US D582,332 S**

(45) **Date of Patent:** **** Dec. 9, 2008**

(54) **WHEEL OR WHEEL COVER**

(75) Inventor: **Oliver Rak**, Pforzheim (DE)

(73) Assignee: **Daimler AG**, Stuttgart (DE)

(**) Term: **14 Years**

(21) Appl. No.: **29/309,409**

(22) Filed: **Aug. 12, 2008**

(30) **Foreign Application Priority Data**

Feb. 19, 2008 (EM) 000881099-0001

(51) **LOC (8) Cl.** **12-16**

(52) **U.S. Cl.** **D12/209**

(58) **Field of Classification Search** D12/204-213;
301/37.101, 64.101, 65, 64.201
See application file for complete search history.

(56) **References Cited**

U.S. PATENT DOCUMENTS

D524,216 S * 7/2006 Scheu D12/211

D532,738 S * 11/2006 Ettensberger D12/211

D542,726 S * 5/2007 Hieke D12/209

D550,140 S * 9/2007 Laengerer D12/211

D566,642 S * 4/2008 Scheu D12/211

D570,760 S * 6/2008 Hieke D12/211

D572,185 S * 7/2008 Pollmann D12/211

D572,649 S * 7/2008 Laengerer D12/211

D574,310 S * 8/2008 Huet D12/209

* cited by examiner

Primary Examiner—Stacia Cadmus

(74) *Attorney, Agent, or Firm*—Crowell & Moring LLP

(57) **CLAIM**

The ornamental design for a wheel or wheel cover, as shown and described.

DESCRIPTION

FIG. 1 is a front view of a wheel or wheel cover according to my novel design; and,

FIG. 2 is a perspective view thereof.

The broken line showing of the rear portion of the wheel rim and the central hub area is included for the purpose of illustrating environment and forms no part of the claimed design.

1 Claim, 1 Drawing Sheet

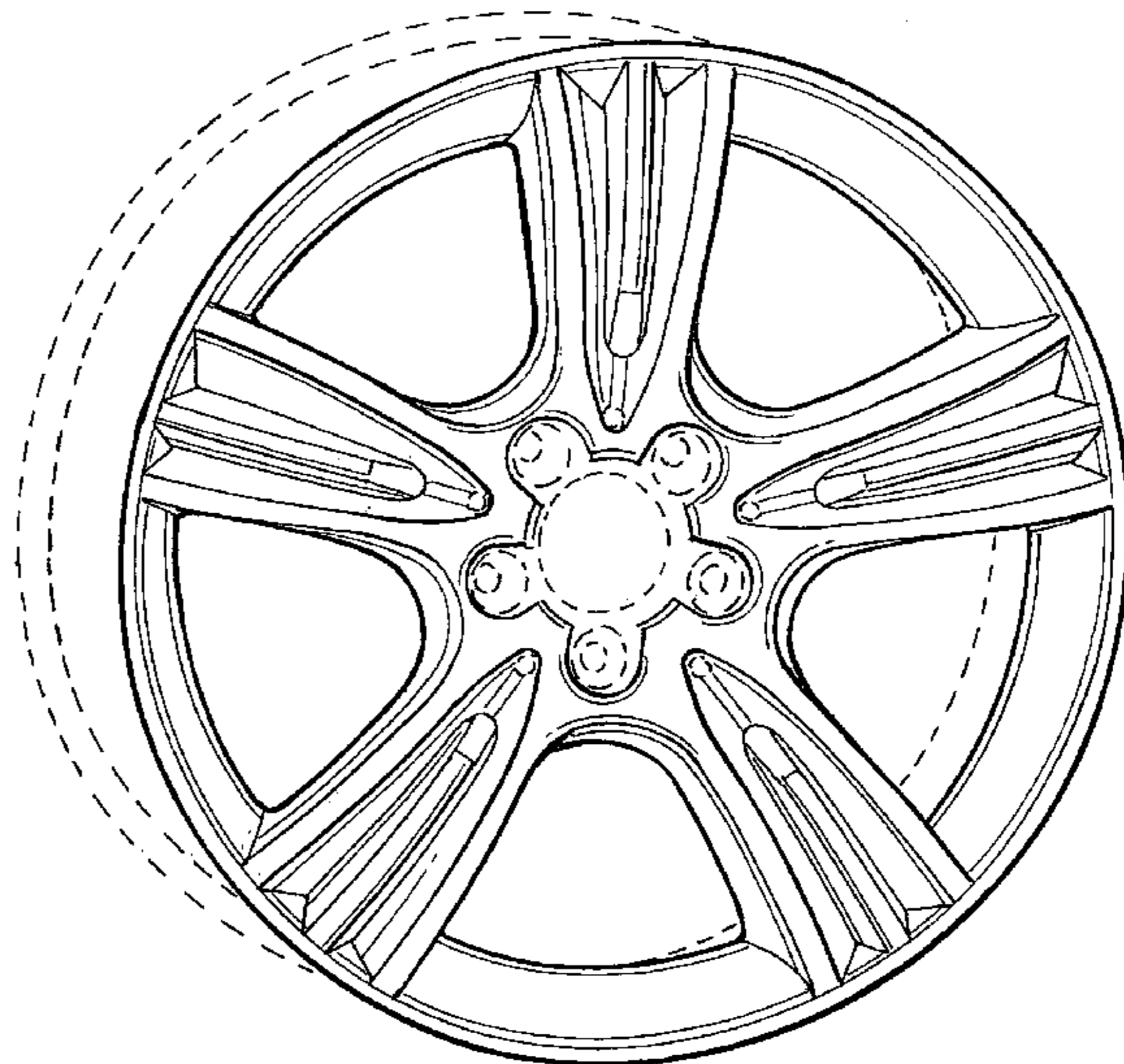
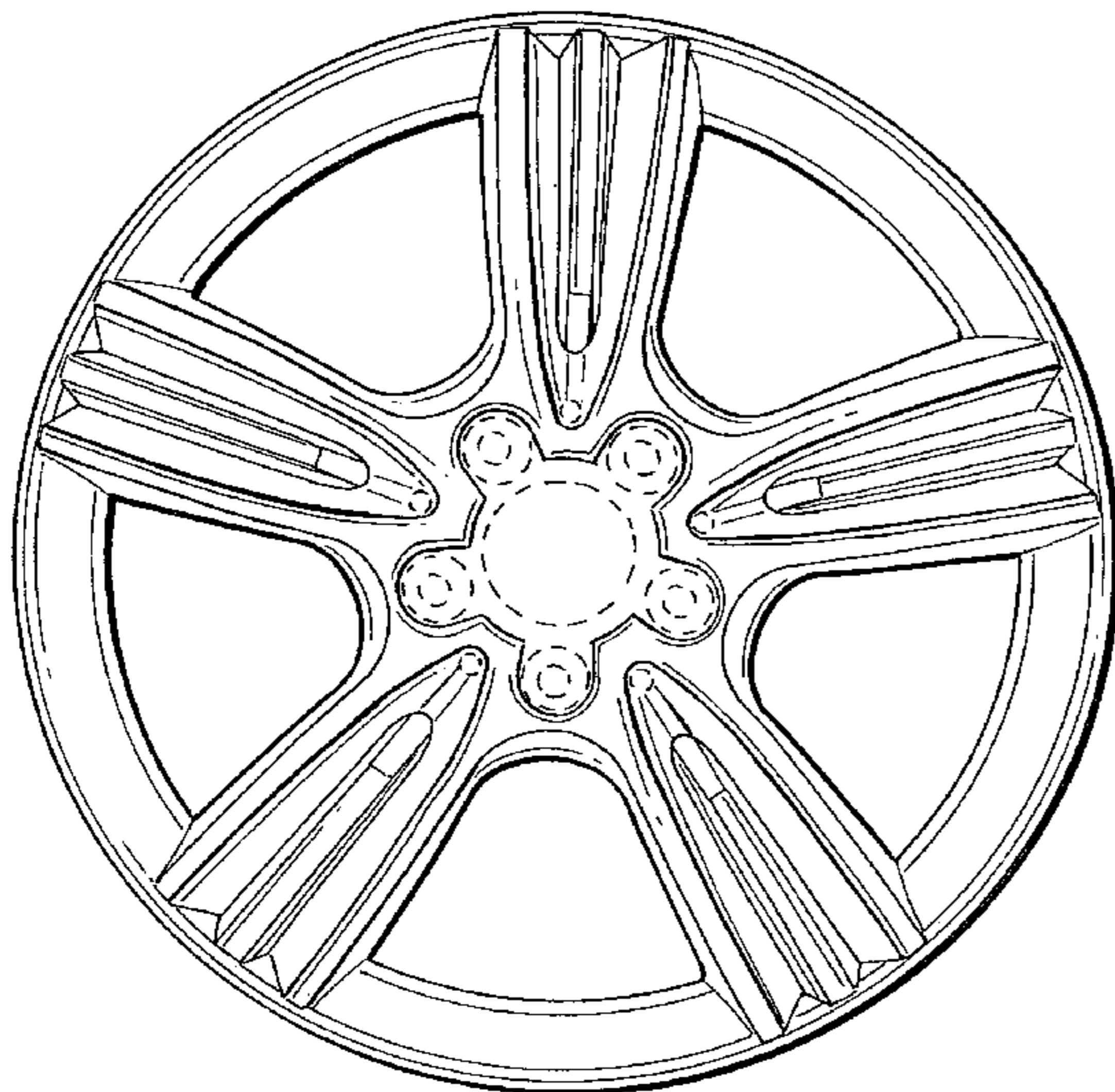

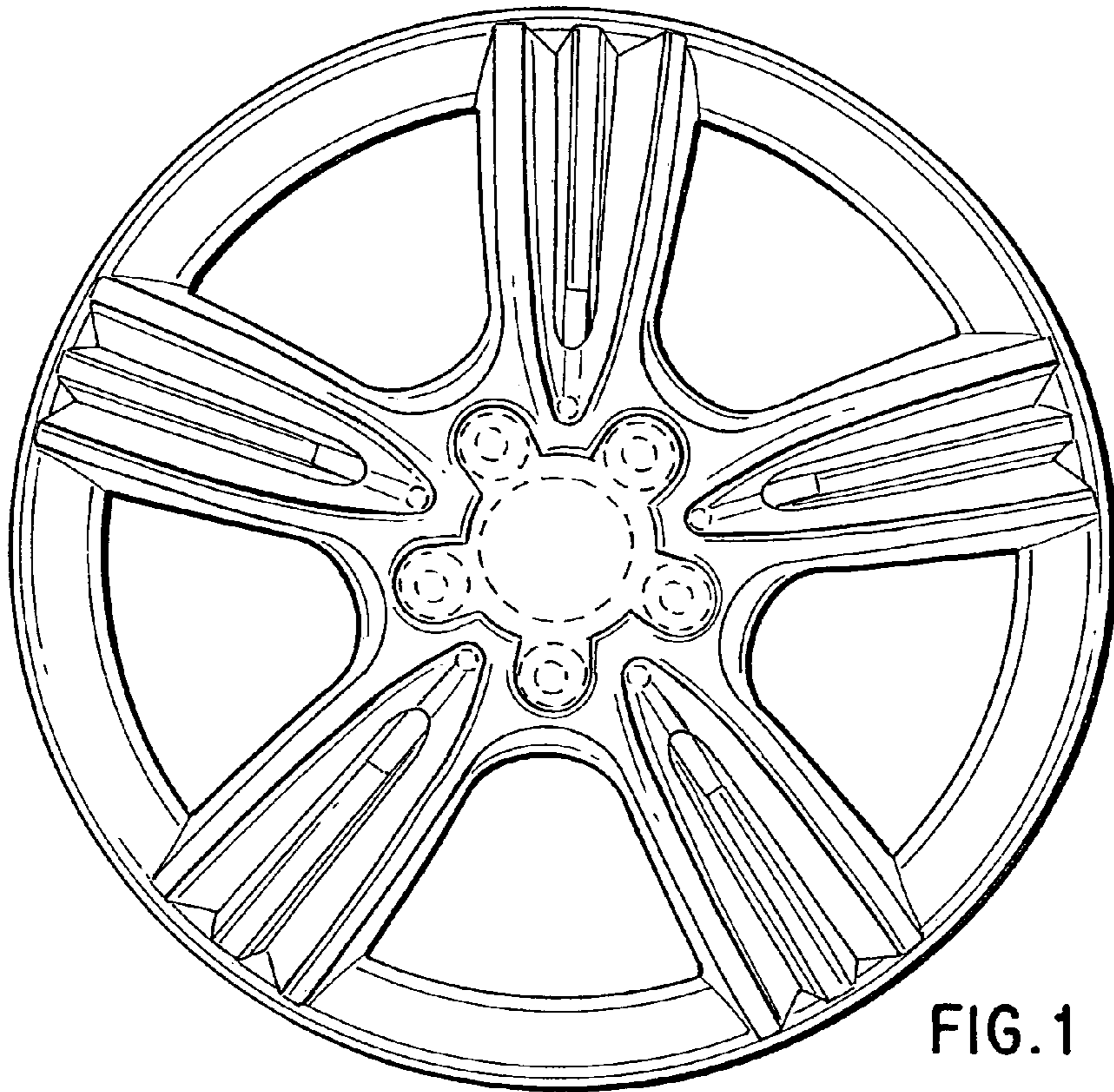

FIG. 1

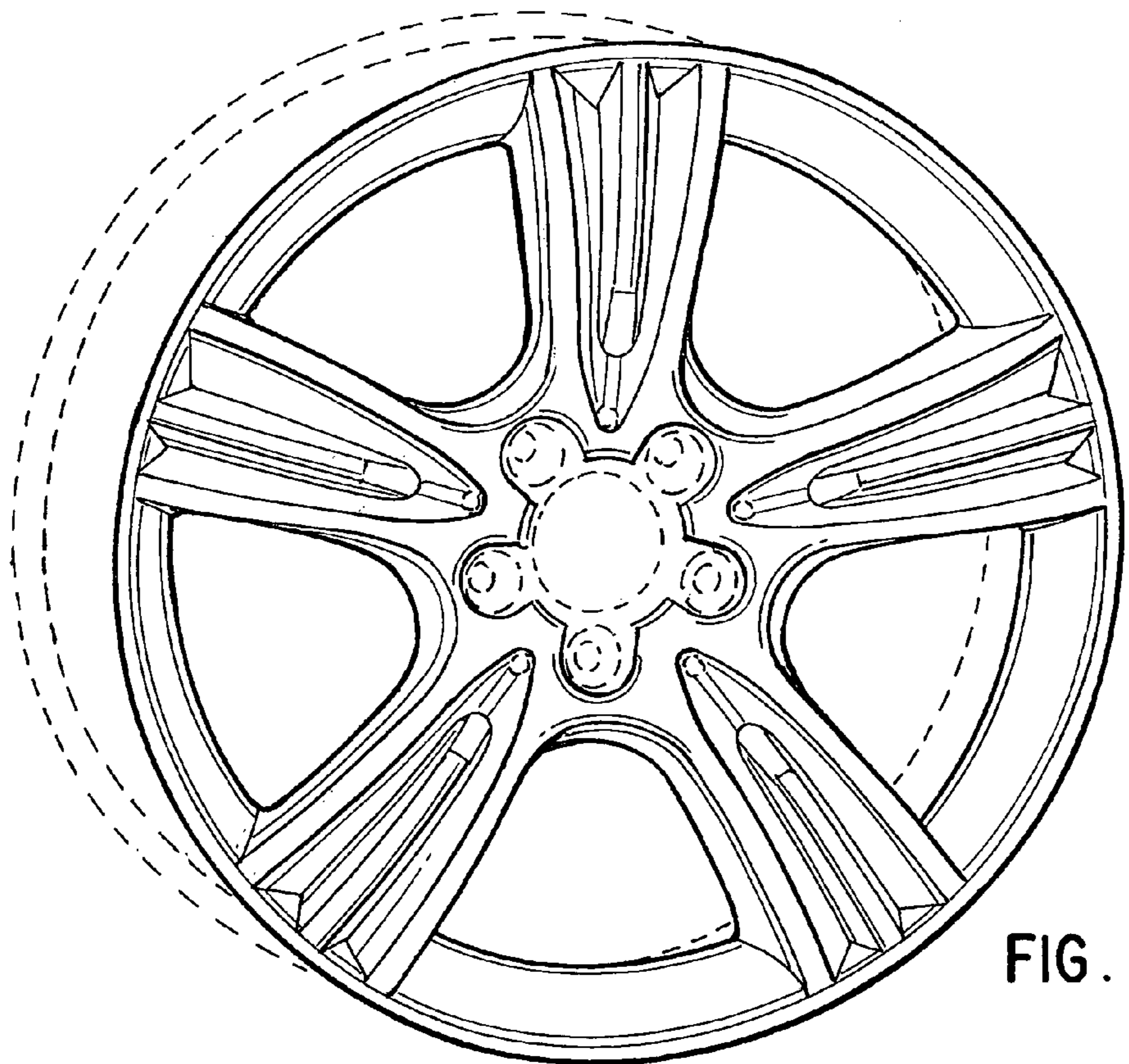

FIG. 2