



US00D582327S

(12) **United States Design Patent**
Ratcliffe

(10) **Patent No.:** **US D582,327 S**

(45) **Date of Patent:** **** Dec. 9, 2008**

(54) **VEHICLE ACCESSORY**

(76) **Inventor:** **Peter Ratcliffe**, 10404 Stevenson Rd.,
Stevenson, MD (US) 21153

(**) **Term:** **14 Years**

(21) **Appl. No.:** **29/319,682**

(22) **Filed:** **Jun. 12, 2008**

Related U.S. Application Data

(62) Division of application No. 29/287,052, filed on Jun. 21, 2007.

(51) **LOC (8) Cl.** **12-16**

(52) **U.S. Cl.** **D12/197**

(58) **Field of Classification Search** D12/197,
D12/110, 114, 198, 218, 201; D7/398, 598,
D7/619; D8/310-312, 107-108; D9/435,
D9/201, 451-454, 443-444; 220/304, 200,
220/203.4, 288, 32-33, 12, 86.1-86.3; 411/300,
411/411, 553, 349; D23/260; D15/150;
280/833, 839

See application file for complete search history.

(56) **References Cited**

U.S. PATENT DOCUMENTS

D250,467 S * 12/1978 O'Banion D12/197

D250,567 S * 12/1978 Breger D7/649
D332,838 S * 1/1993 Lu D26/34
D397,317 S * 8/1998 Hoagland, IV D12/189
5,829,153 A * 11/1998 Hitchcock 33/728
2007/0210086 A1 * 9/2007 Behnamrad et al. 220/303

* cited by examiner

Primary Examiner—Robert M. Spear

Assistant Examiner—Katrina A Kile

(74) *Attorney, Agent, or Firm*—The Nath Law Group; Jerald L. Meyer; Derek Richmond

(57) **CLAIM**

The ornamental design for a vehicle accessory, as shown and described.

DESCRIPTION

FIG. 1 is a perspective view of a vehicle accessory;
FIG. 2 is a right side view of the vehicle accessory;
FIG. 3 is a front side view of the vehicle accessory;
FIG. 4 is a rear side view of the vehicle accessory;
FIG. 5 is a top view of the vehicle accessory; and,
FIG. 6 is a bottom view of the vehicle accessory.

Those portions of the drawings shown in broken lines are unclaimed subject matter and form no part of the claimed design.

1 Claim, 3 Drawing Sheets

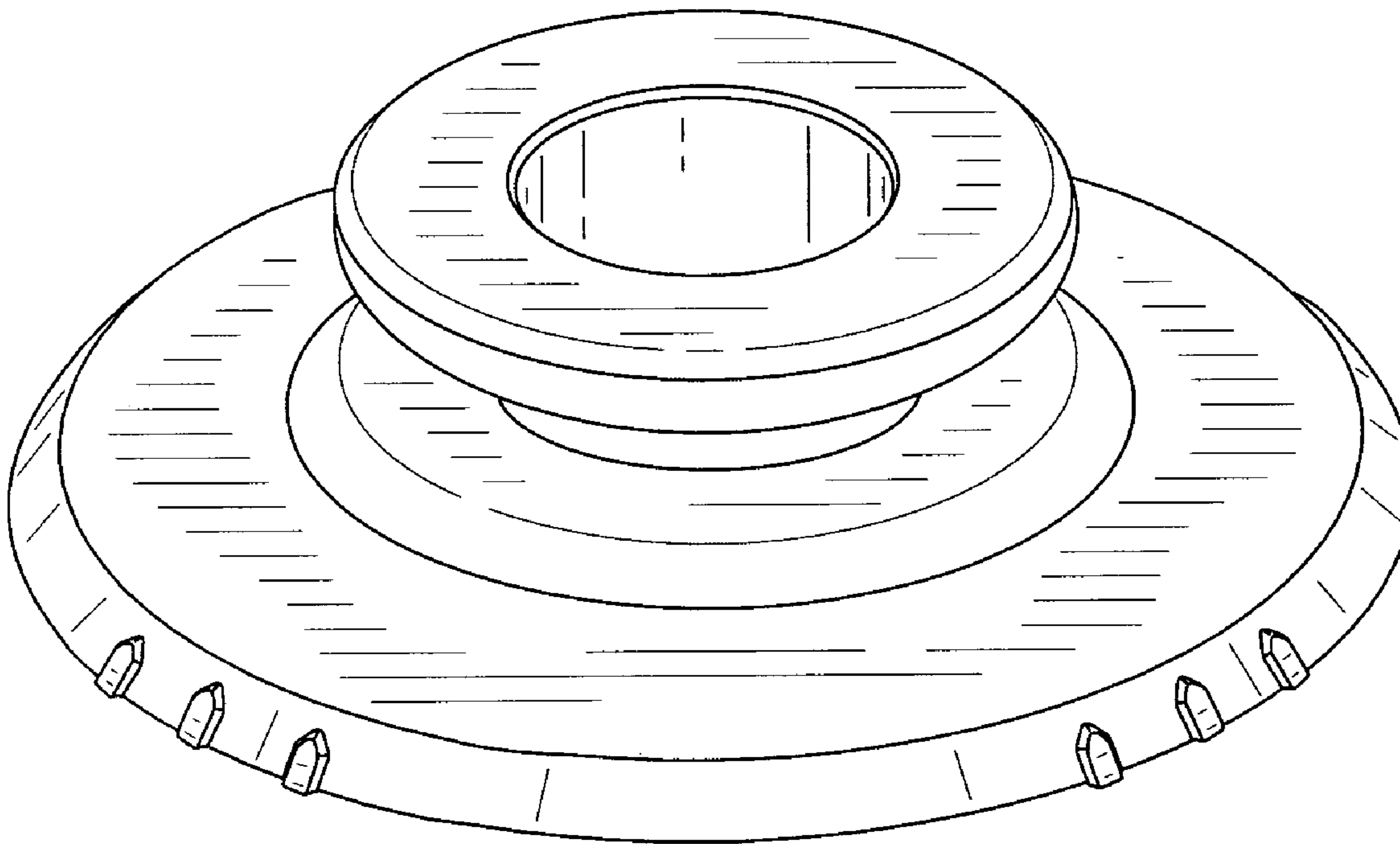

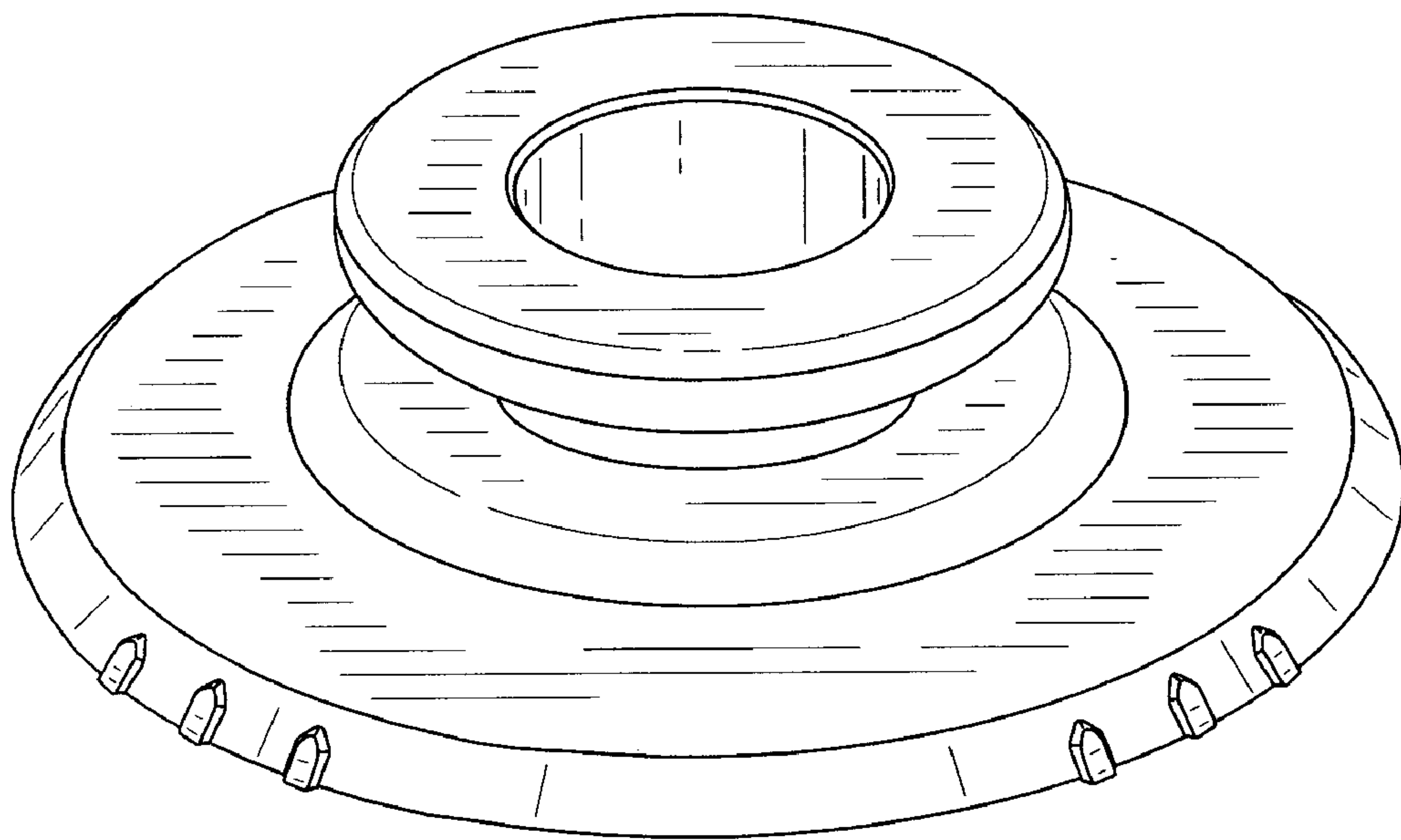

FIG. 1

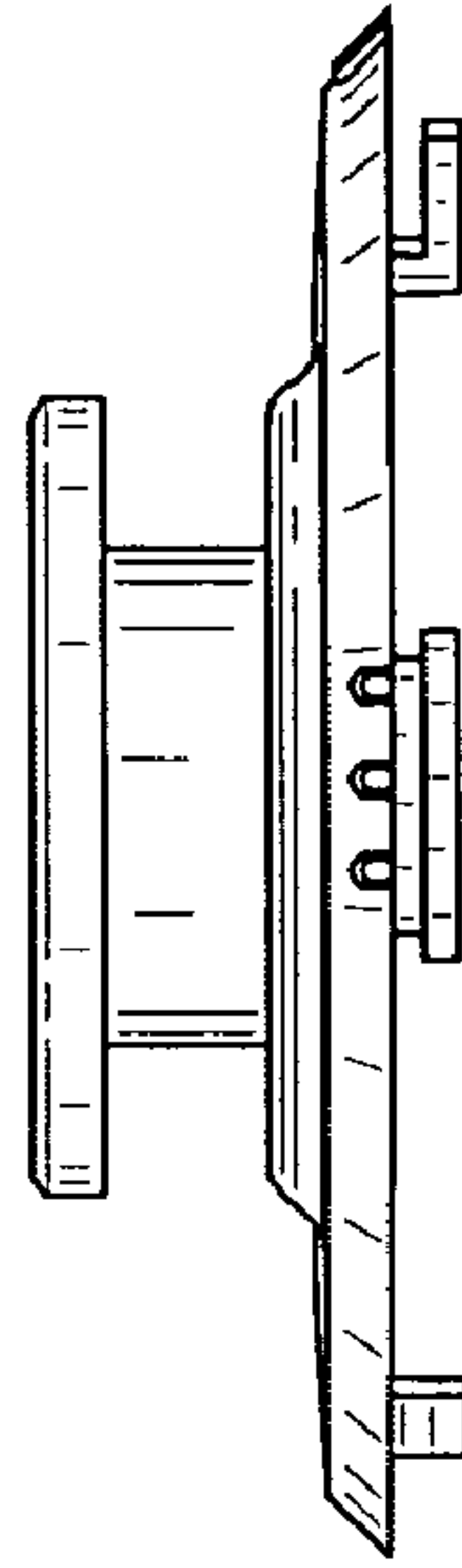

FIG. 2

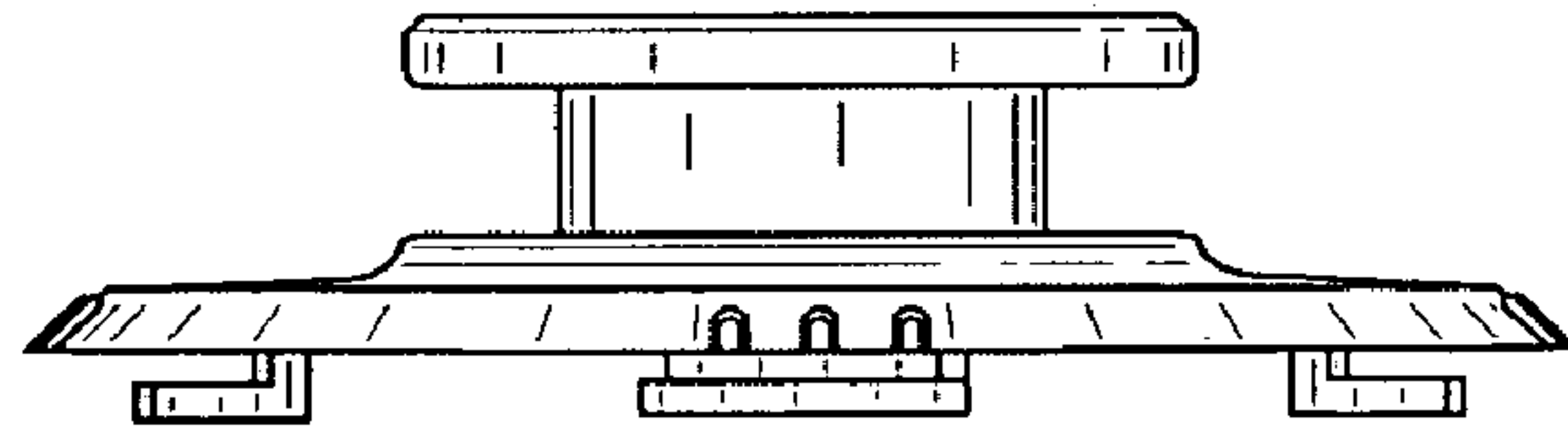

FIG. 3

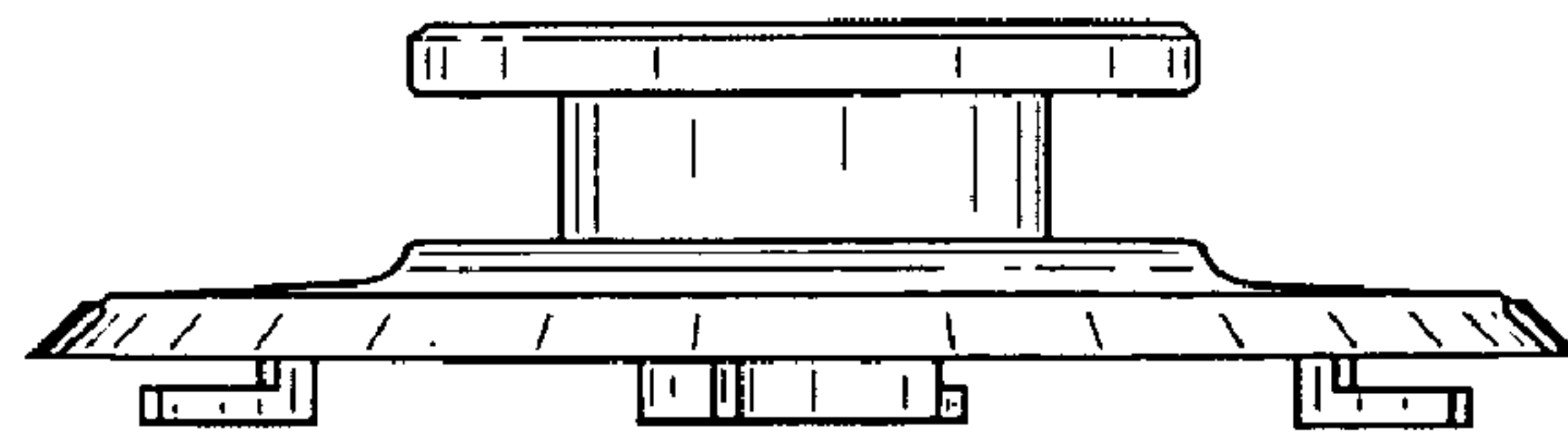

FIG. 4

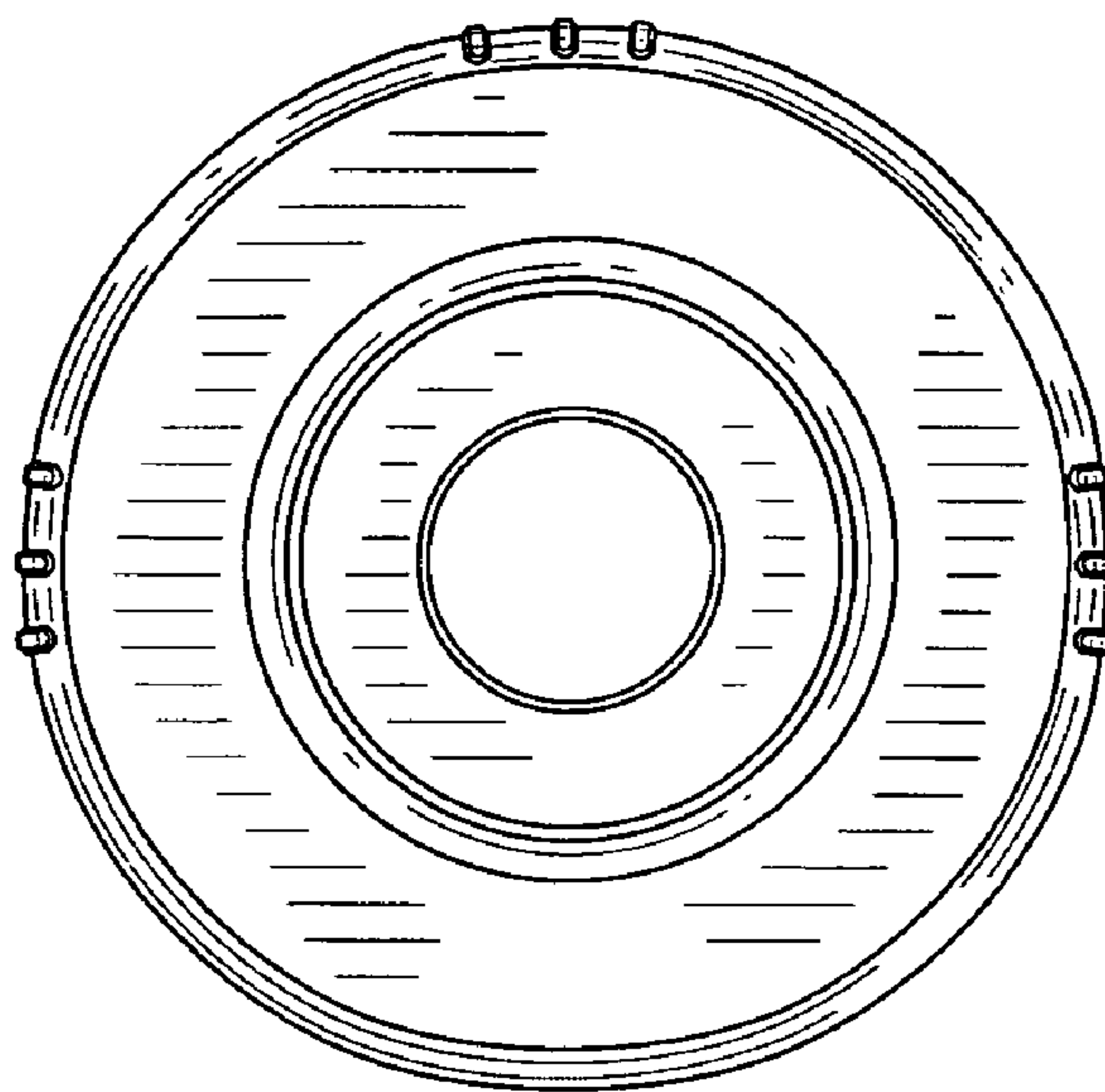

FIG. 5

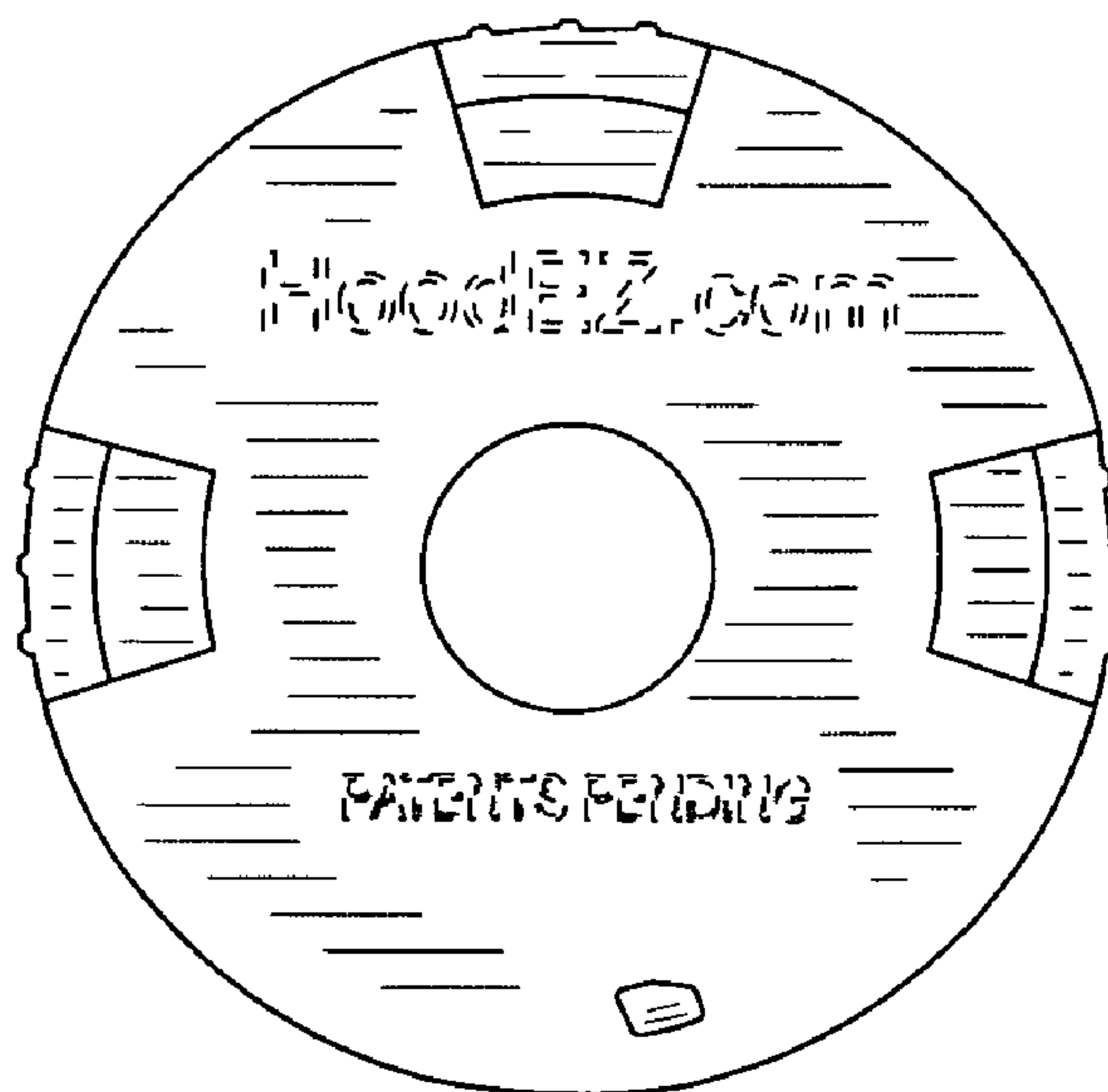

FIG. 6