



US00D582326S

(12) **United States Design Patent**
Shimizu

(10) **Patent No.:** **US D582,326 S**
(45) **Date of Patent:** **** Dec. 9, 2008**

(54) **METER FOR AUTOMOBILES**

(75) Inventor: **Yosuke Shimizu**, Wako (JP)

(73) Assignee: **Honda Motor Co., Ltd.**, Tokyo (JP)

(**) Term: **14 Years**

(21) Appl. No.: **29/305,490**

(22) Filed: **Mar. 21, 2008**

(30) **Foreign Application Priority Data**

Sep. 21, 2007 (JP) 2007-025609

(51) **LOC (8) Cl.** **12-16**

(52) **U.S. Cl.** **D12/192**

(58) **Field of Classification Search** D12/192,
D12/415; 180/190; 280/750-752; 296/190.01-190.09,
296/70; D15/17, 28; D10/46, 98, 102-103
See application file for complete search history.

(56) **References Cited**

U.S. PATENT DOCUMENTS

- D470,090 S * 2/2003 Sawabe D12/192
- D472,506 S * 4/2003 Wiedeman et al. D12/192
- D480,341 S * 10/2003 Day D12/192
- D489,661 S * 5/2004 McPeck et al. D12/192

- D498,191 S * 11/2004 Nakajima et al. D12/192
- D511,729 S * 11/2005 Yamazaki et al. D12/192
- D529,847 S * 10/2006 Montijo et al. D12/192
- D538,720 S * 3/2007 Yeung D12/192
- D549,143 S * 8/2007 Lepage D12/192
- D562,748 S * 2/2008 Tanaka et al. D12/192

* cited by examiner

Primary Examiner—Stacia Cadmus

(74) *Attorney, Agent, or Firm*—Westerman, Hattori, Daniels & Adrian, LLP.

(57) **CLAIM**

The ornamental design for a meter for automobiles, as shown and described.

DESCRIPTION

FIG. 1: a front view of the meter;

FIG. 2: a front plan view of the meter;

FIG. 3: a right side view of the meter, the left side being a mirror image thereof; and,

FIG. 4: a front perspective view of the meter.

The broken lines are environmental structure and form no part of the claimed design.

1 Claim, 2 Drawing Sheets

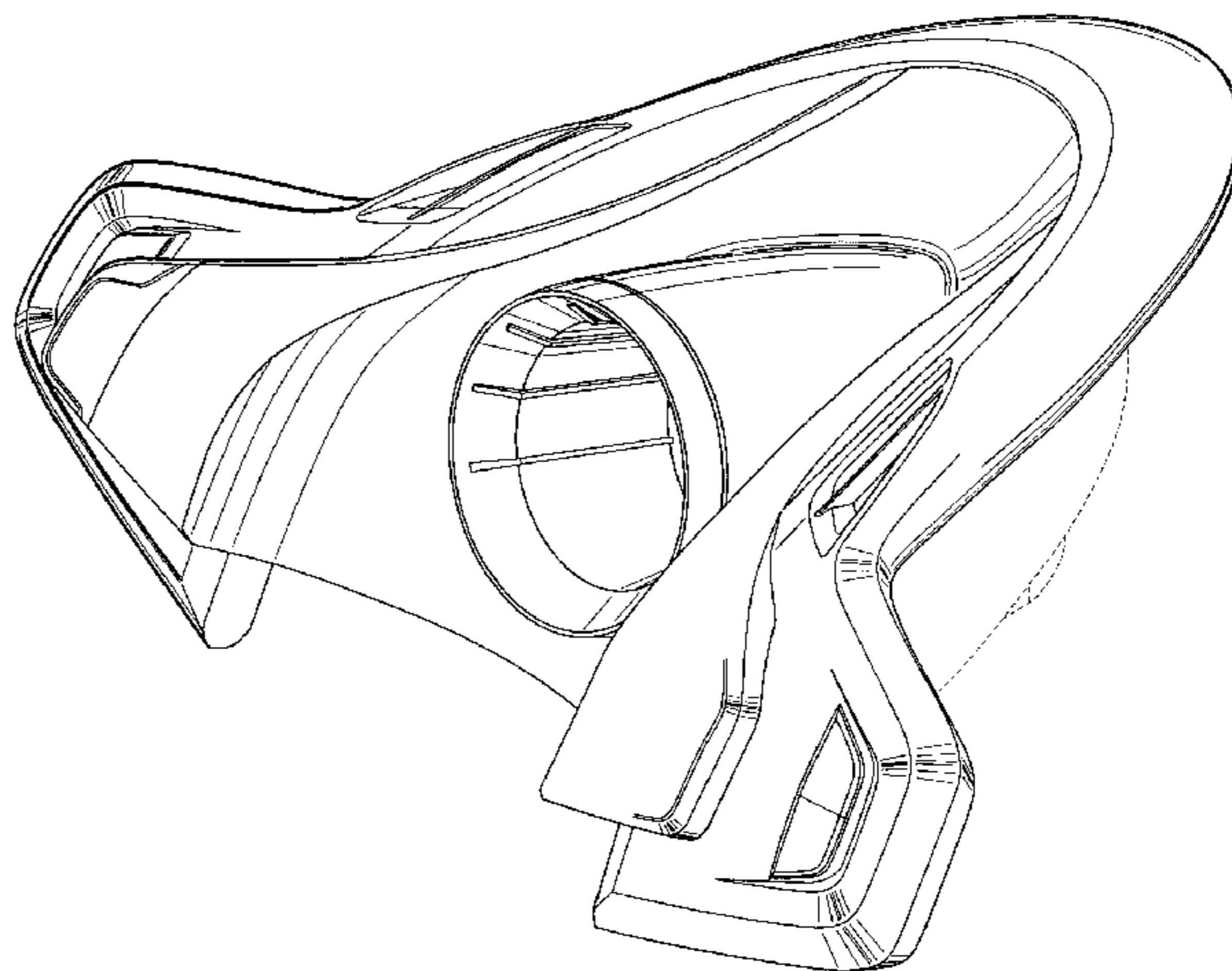
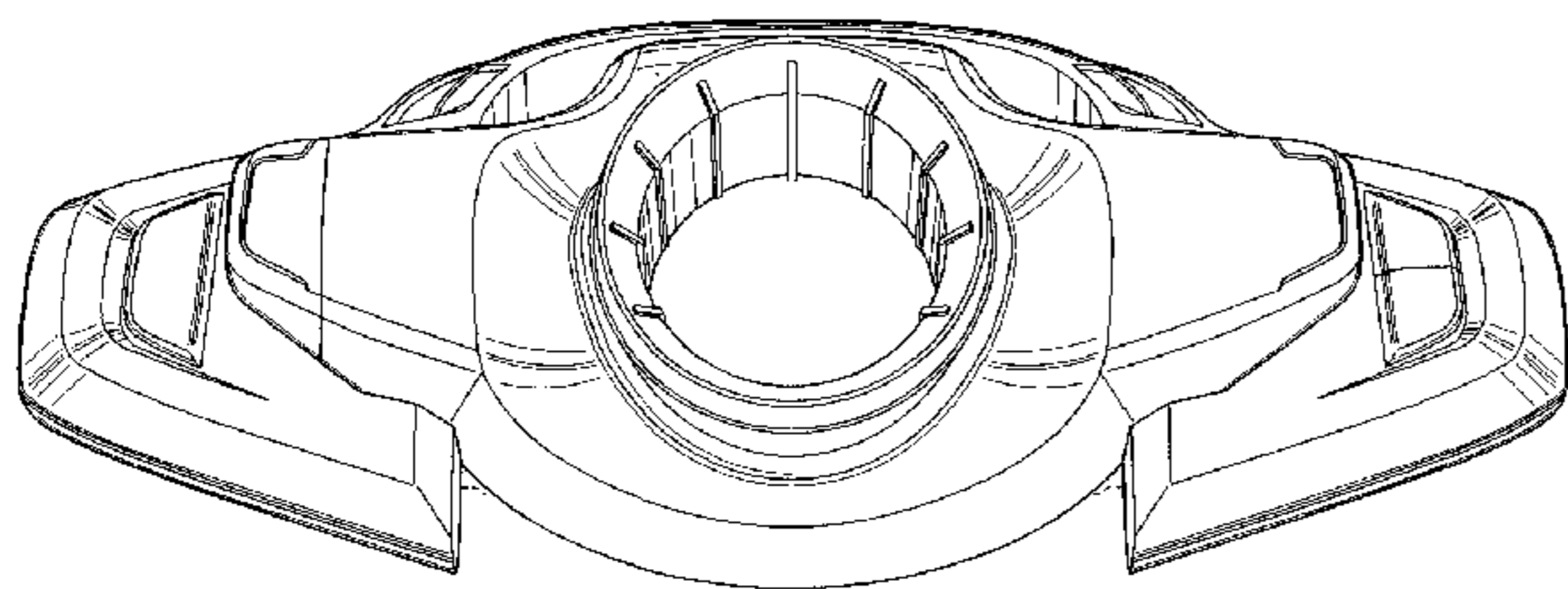

FIG.1

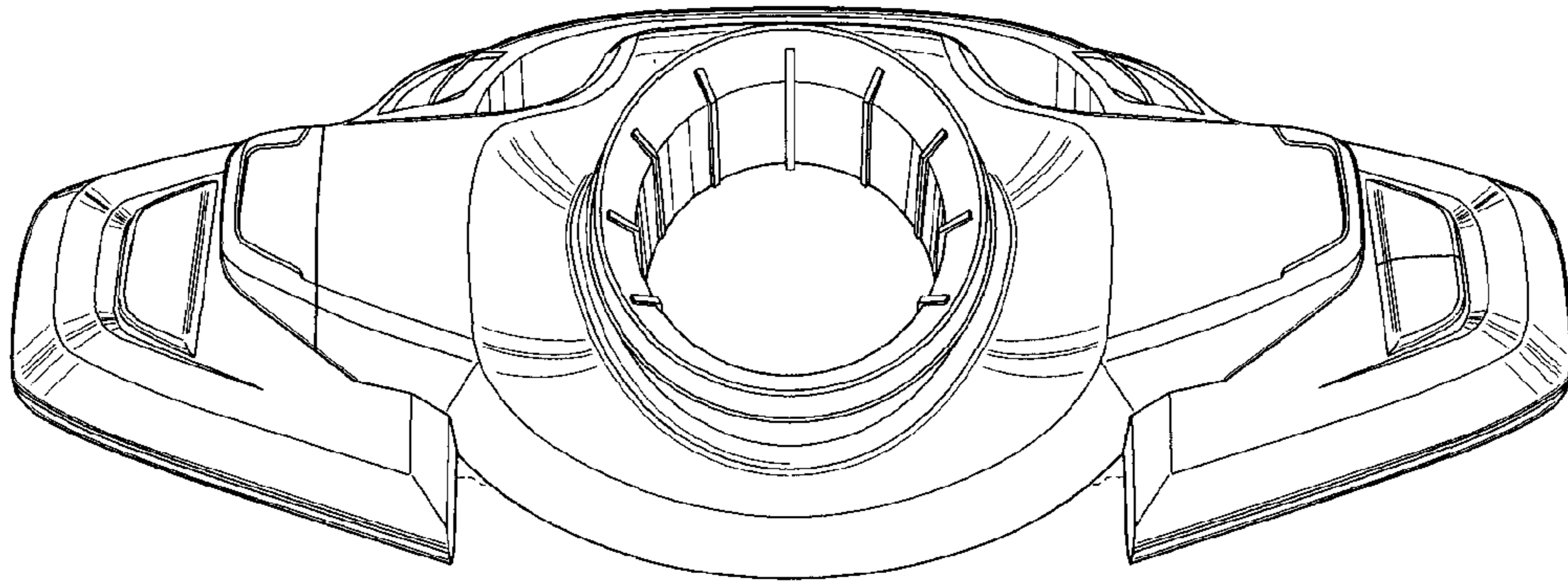

FIG.2

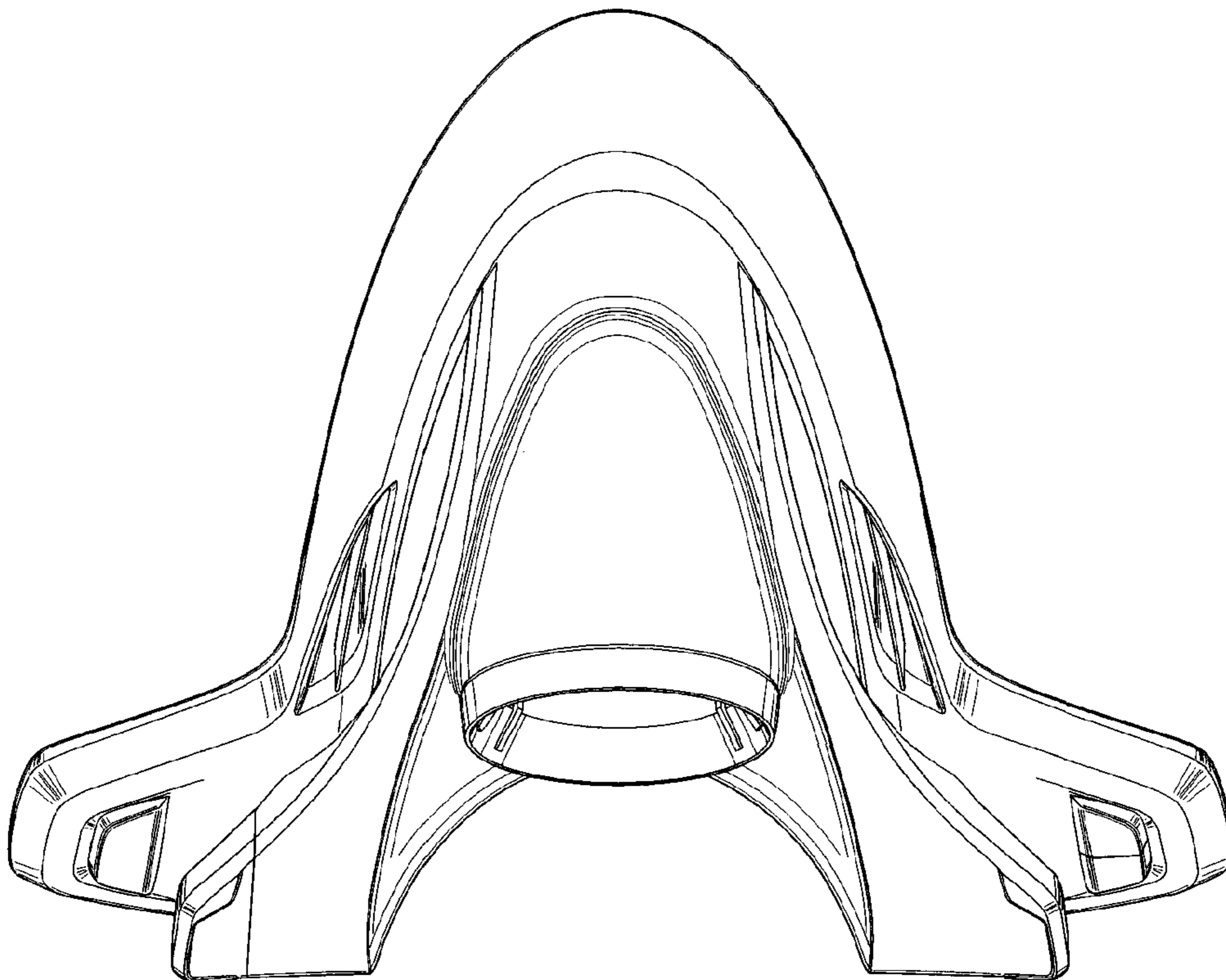

FIG.3

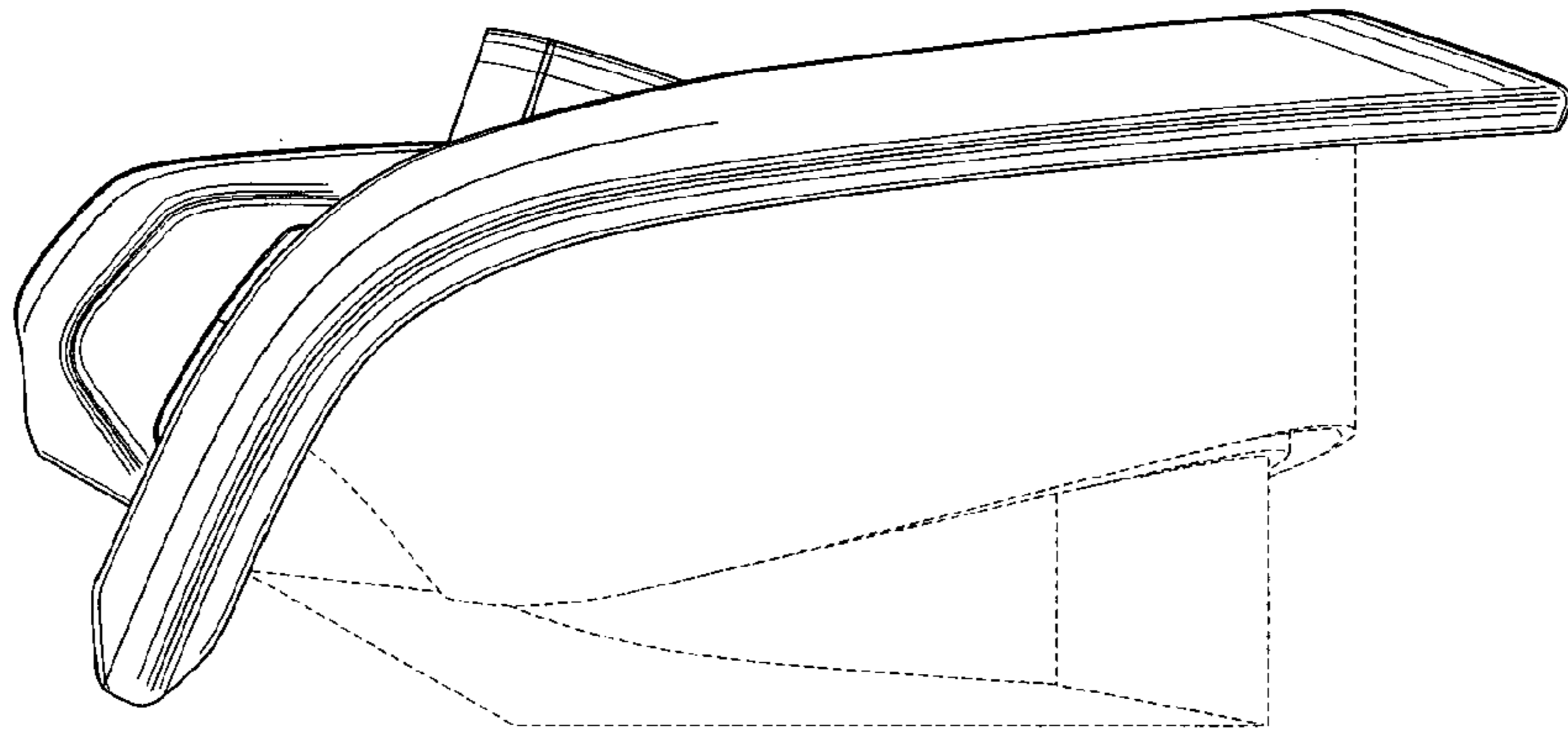

FIG.4

