



US00D582318S

(12) **United States Design Patent**
Kishi et al.

(10) **Patent No.:** **US D582,318 S**

(45) **Date of Patent:** **** Dec. 9, 2008**

(54) **MOTORCYCLE**

D531,090 S * 10/2006 Iimura D12/110
D559,738 S * 1/2008 Takigawa et al. D12/110

(75) Inventors: **Toshiaki Kishi**, Wako (JP); **Toshio Kurihara**, Wako (JP)

* cited by examiner

(73) Assignee: **Honda Motor Co., Ltd.**, Tokyo (JP)

Primary Examiner—Cathron Brooks

Assistant Examiner—Linda Brooks

(**) Term: **14 Years**

(74) *Attorney, Agent, or Firm*—Birch, Stewart, Kolasch & Birch, LLP

(21) Appl. No.: **29/300,230**

(57) **CLAIM**

(22) Filed: **Feb. 29, 2008**

What is claimed is; the ornamental design for, a motorcycle, as shown and described.

(30) **Foreign Application Priority Data**

Sep. 3, 2007 (JP) 2007-023925

DESCRIPTION

(51) **LOC (8) Cl.** **12-11**

FIG. 1 is a first perspective view of a motorcycle, showing our new design;

(52) **U.S. Cl.** **D12/110**

FIG. 2 is a second perspective view thereof;

(58) **Field of Classification Search** D12/110;
180/219

FIG. 3 is a front elevation view thereof;

See application file for complete search history.

FIG. 4 is a rear elevation view thereof;

(56) **References Cited**

FIG. 5 is a top plan view thereof;

U.S. PATENT DOCUMENTS

FIG. 6 is a right side elevation view thereof; and,

D268,999 S * 5/1983 Nakano et al. D12/110

FIG. 7 is a left side elevation view thereof.

D288,796 S * 3/1987 Nakano et al. D12/110

1 Claim, 7 Drawing Sheets

D516,468 S * 3/2006 Kuboshima et al. D12/110

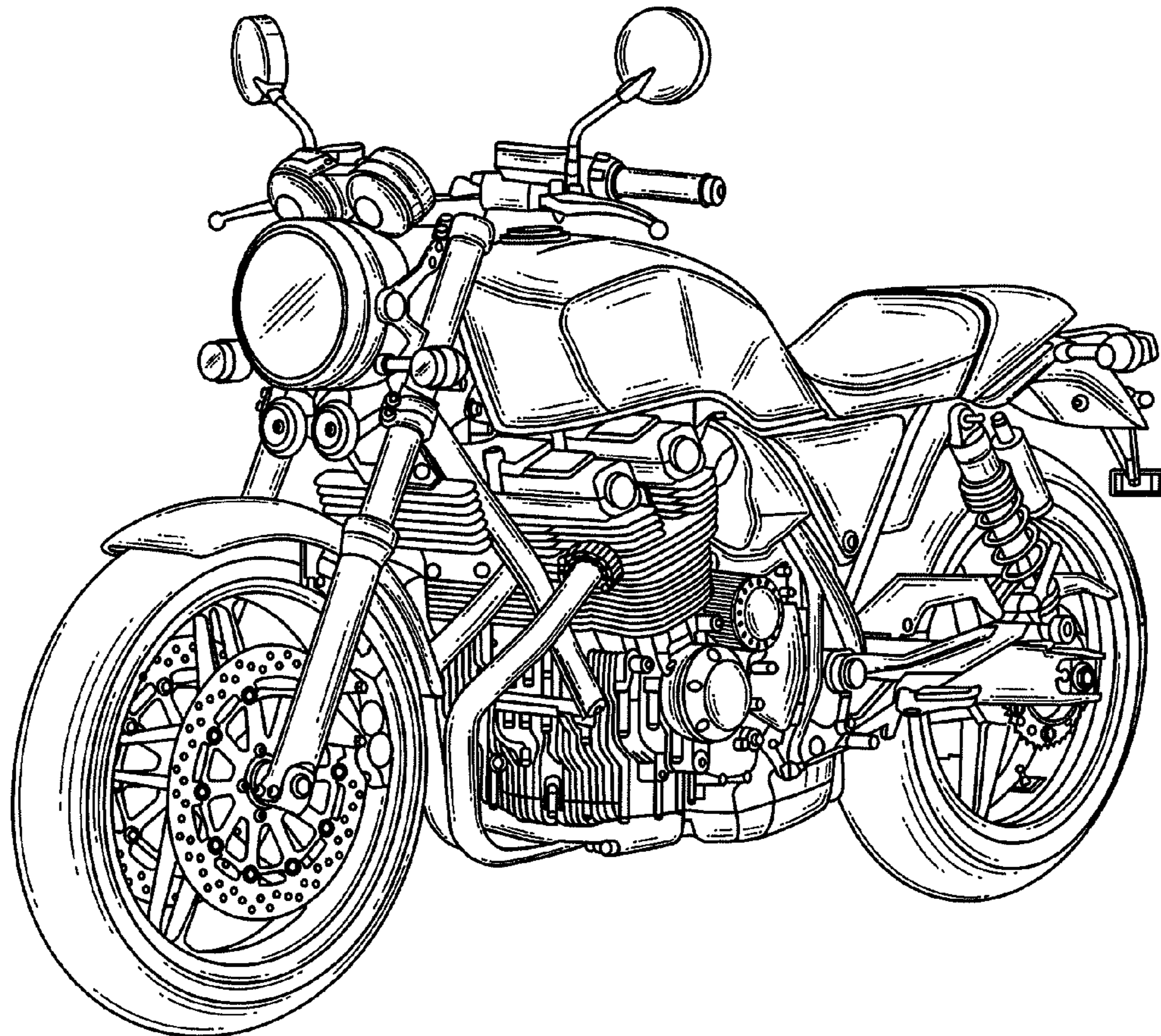

Fig. 1

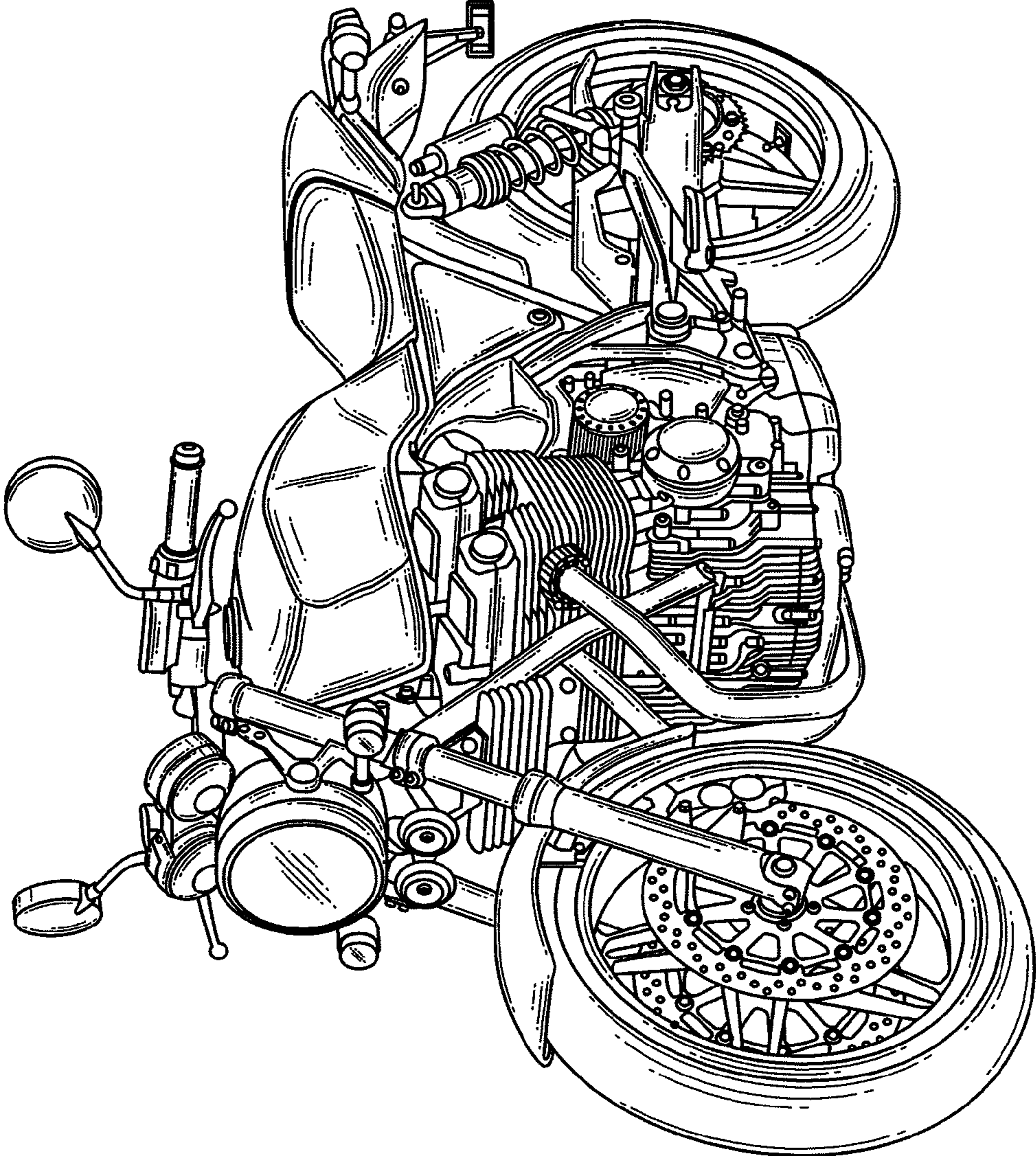

Fig. 2

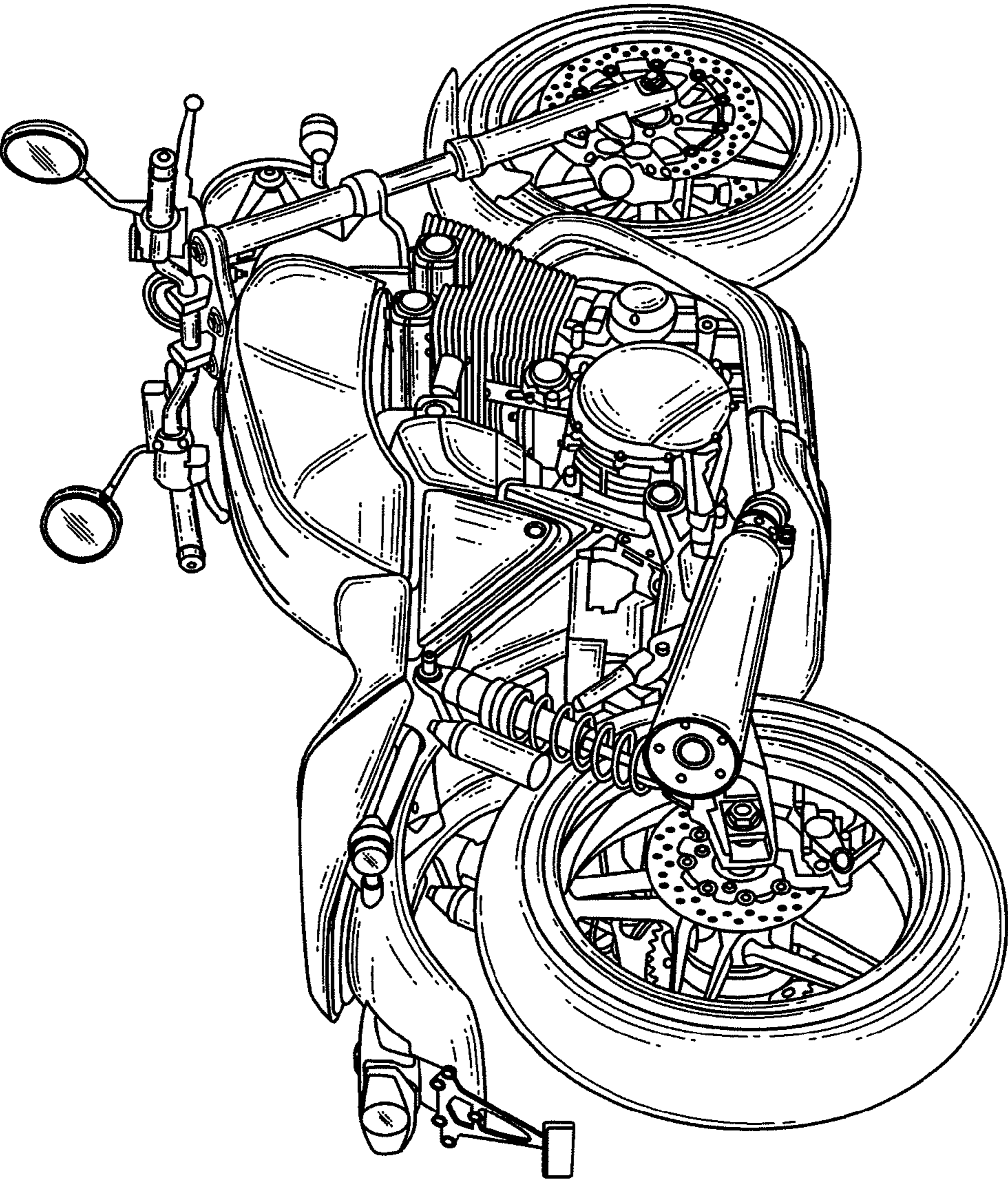

Fig. 3

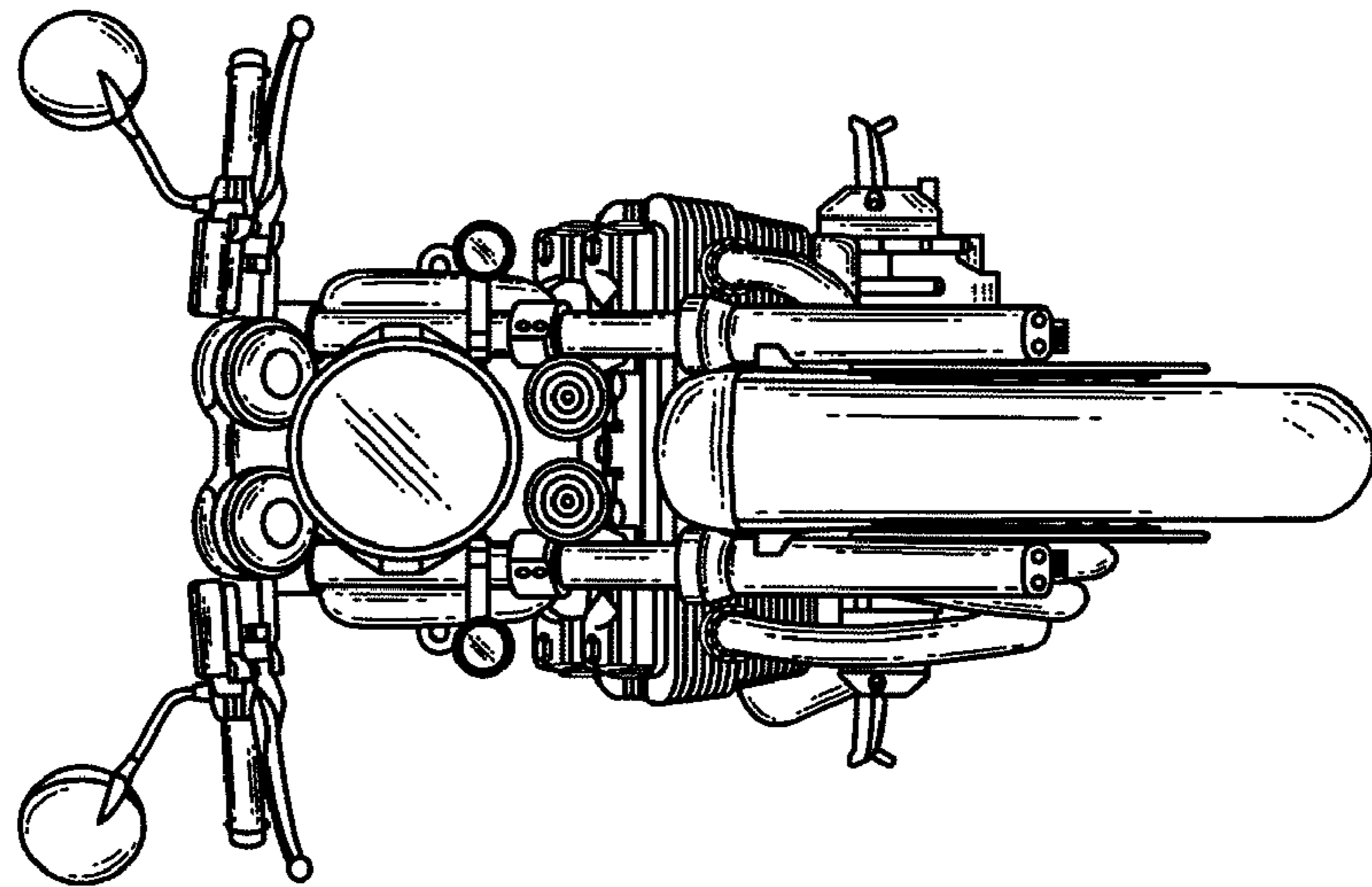

Fig. 4

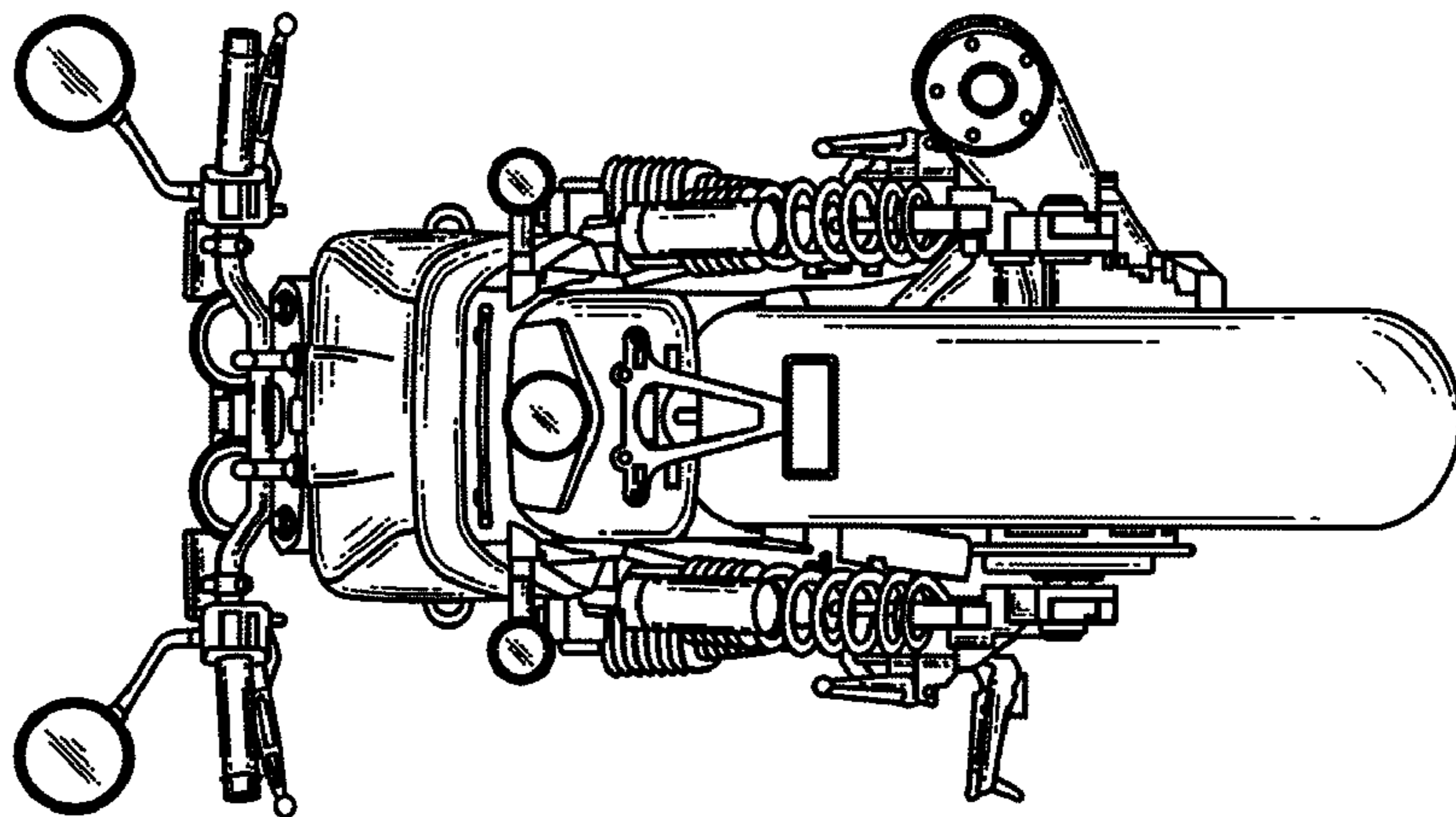

Fig. 5

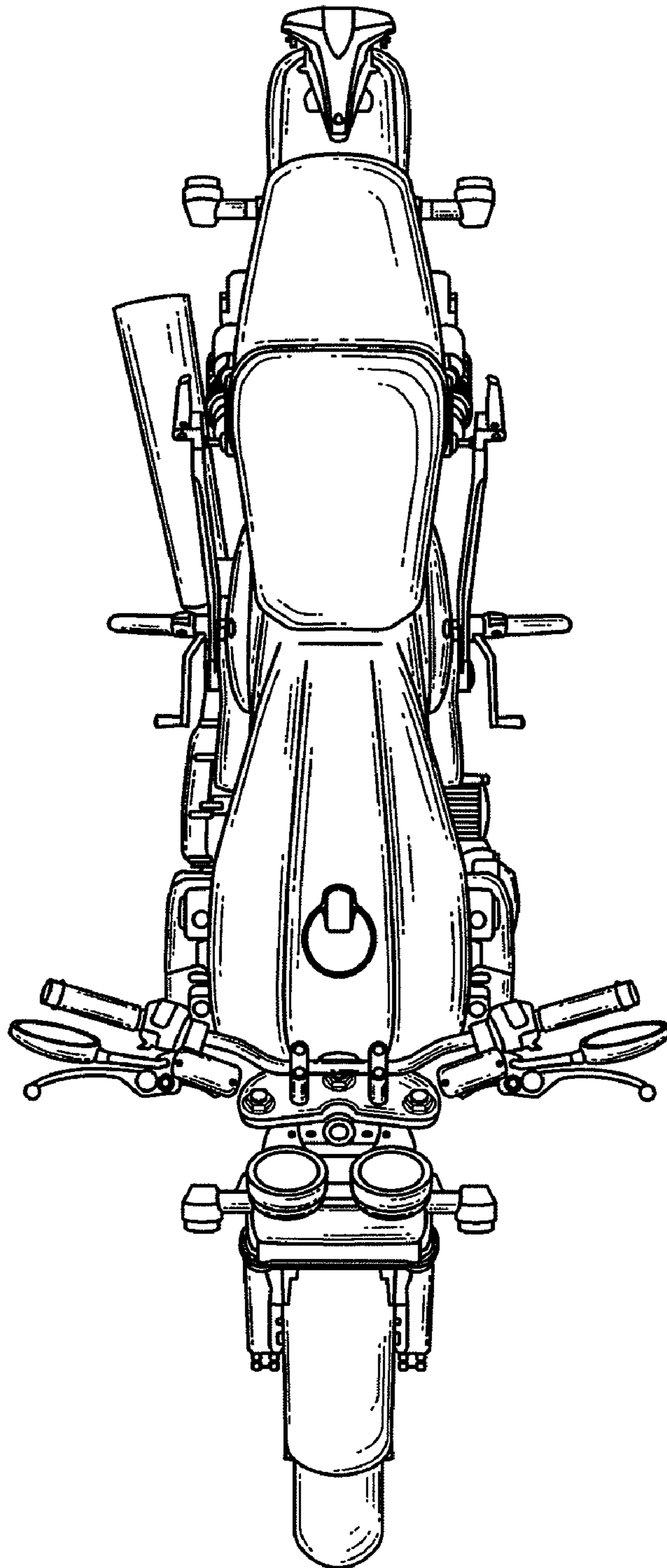

Fig. 6

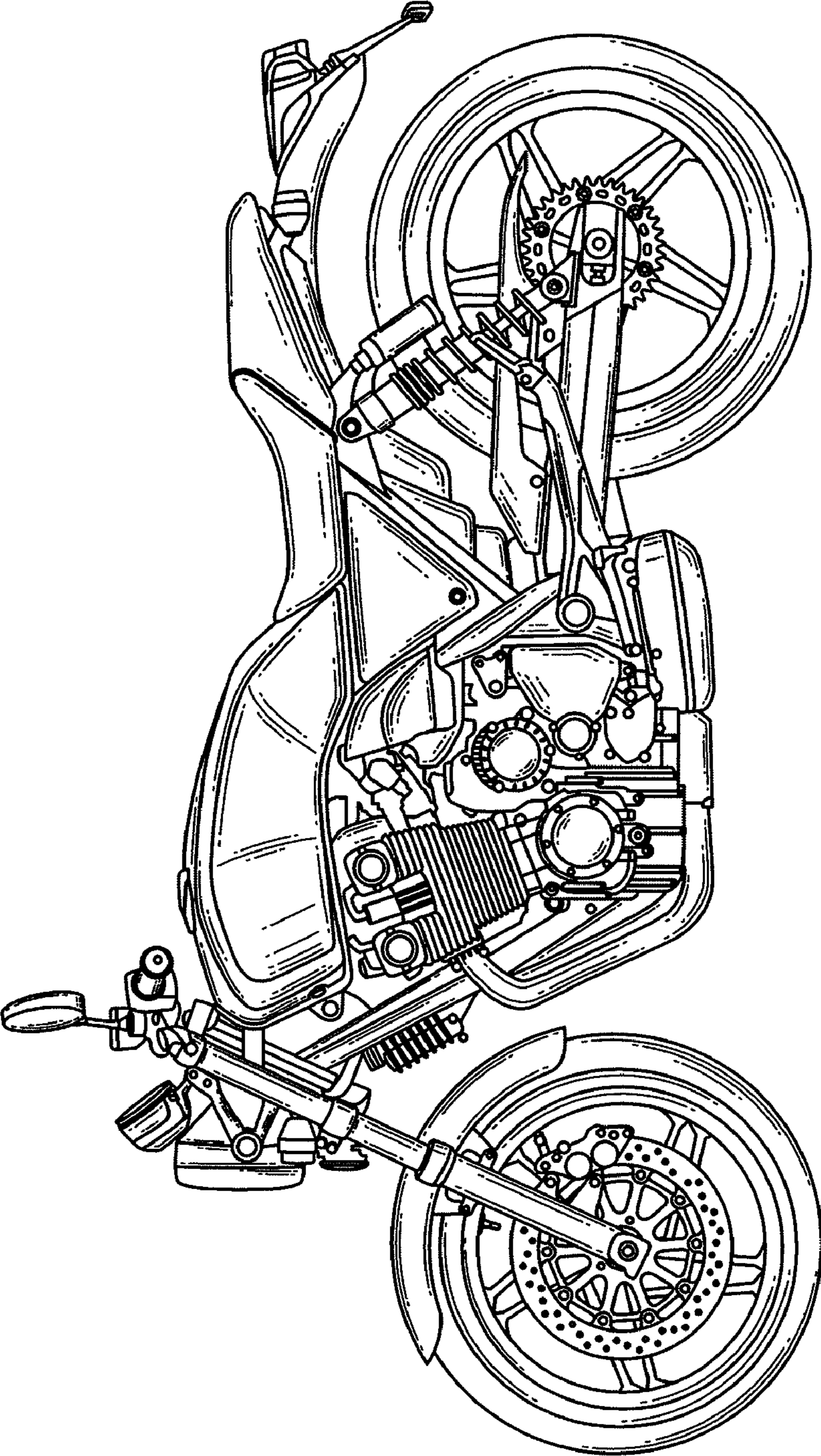

Fig. 7

