



US00D582105S

(12) **United States Design Patent**  
**Cho et al.**

(10) **Patent No.:** **US D582,105 S**  
(45) **Date of Patent:** **\*\* Dec. 2, 2008**

(54) **WASHING MACHINE**

(75) Inventors: **Kyeong Chul Cho**, Seoul (KR); **Bo Won Suh**, Gwangmyeong-Shi (KR); **Seung Hyun Song**, Seoul (KR); **Hyoung Won Roh**, Seoul (KR)

(73) Assignee: **LG Electronics Inc.**, Seoul (KR)

(\*\*) Term: **14 Years**

(21) Appl. No.: **29/300,722**

(22) Filed: **Apr. 30, 2008**

(30) **Foreign Application Priority Data**

Nov. 1, 2007 (KR) ..... 30-2007-0045637

(51) **LOC (8) Cl.** ..... **15-05**

(52) **U.S. Cl.** ..... **D32/6**

(58) **Field of Classification Search** ..... D32/1,  
D32/5-6, 8, 10; 68/3 R, 5 R, 12.01, 12.08,  
68/212; 34/523-524, 87-88, 58, 108, 130-132,  
34/595-597, 600, 417, 499, 534; 312/31  
See application file for complete search history.

(56) **References Cited**

**U.S. PATENT DOCUMENTS**

D496,709 S \* 9/2004 Suh et al. .... D32/6  
D517,257 S \* 3/2006 Kim et al. .... D32/6  
D517,756 S \* 3/2006 Ha et al. .... D32/6  
D520,686 S \* 5/2006 Jeon et al. .... D32/6

D528,712 S \* 9/2006 Ha et al. .... D32/6  
D528,713 S \* 9/2006 Ha et al. .... D32/6  
D529,242 S \* 9/2006 Ha et al. .... D32/6  
D550,907 S \* 9/2007 Jeon et al. .... D32/6  
D551,401 S \* 9/2007 Jeon et al. .... D32/6  
D552,807 S \* 10/2007 Jeon et al. .... D32/6  
D559,480 S \* 1/2008 Kwon et al. .... D32/6  
D572,419 S \* 7/2008 Park et al. .... D32/6

\* cited by examiner

*Primary Examiner*—Ian Simmons

*Assistant Examiner*—Kathleen M Sims

(74) *Attorney, Agent, or Firm*—Morgan Lewis & Bockius LLP

(57) **CLAIM**

We claim the ornamental design for a washing machine, as shown and described.

**DESCRIPTION**

FIG. 1 is a perspective view of a washing machine showing our new design;

FIG. 2 is a front elevation view thereof;

FIG. 3 is a rear elevation view thereof;

FIG. 4 is a left-side elevation view thereof;

FIG. 5 is a right-side elevation view thereof;

FIG. 6 is a top plan view thereof; and,

FIG. 7 is a bottom plan view thereof.

**1 Claim, 6 Drawing Sheets**

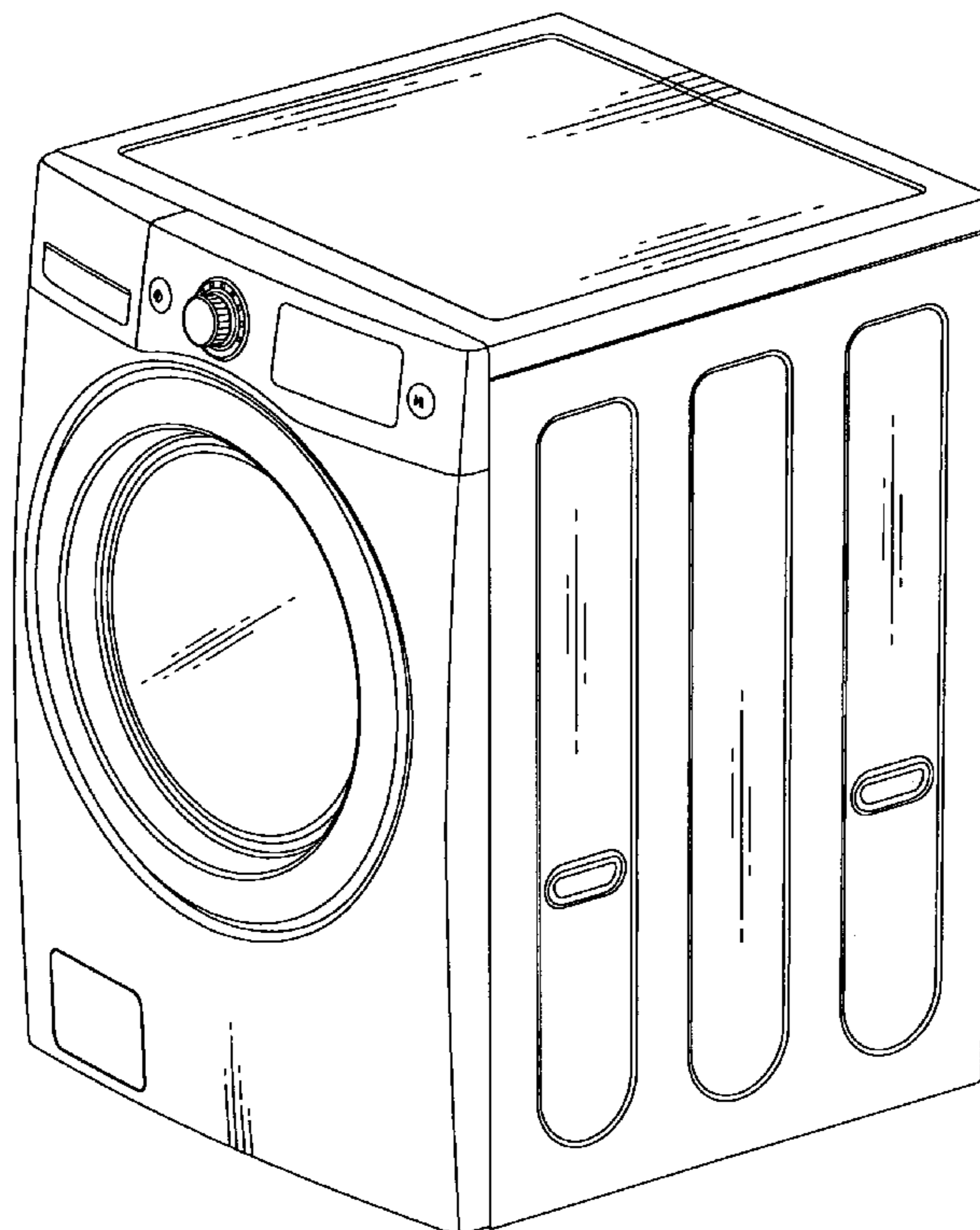

FIG. 1

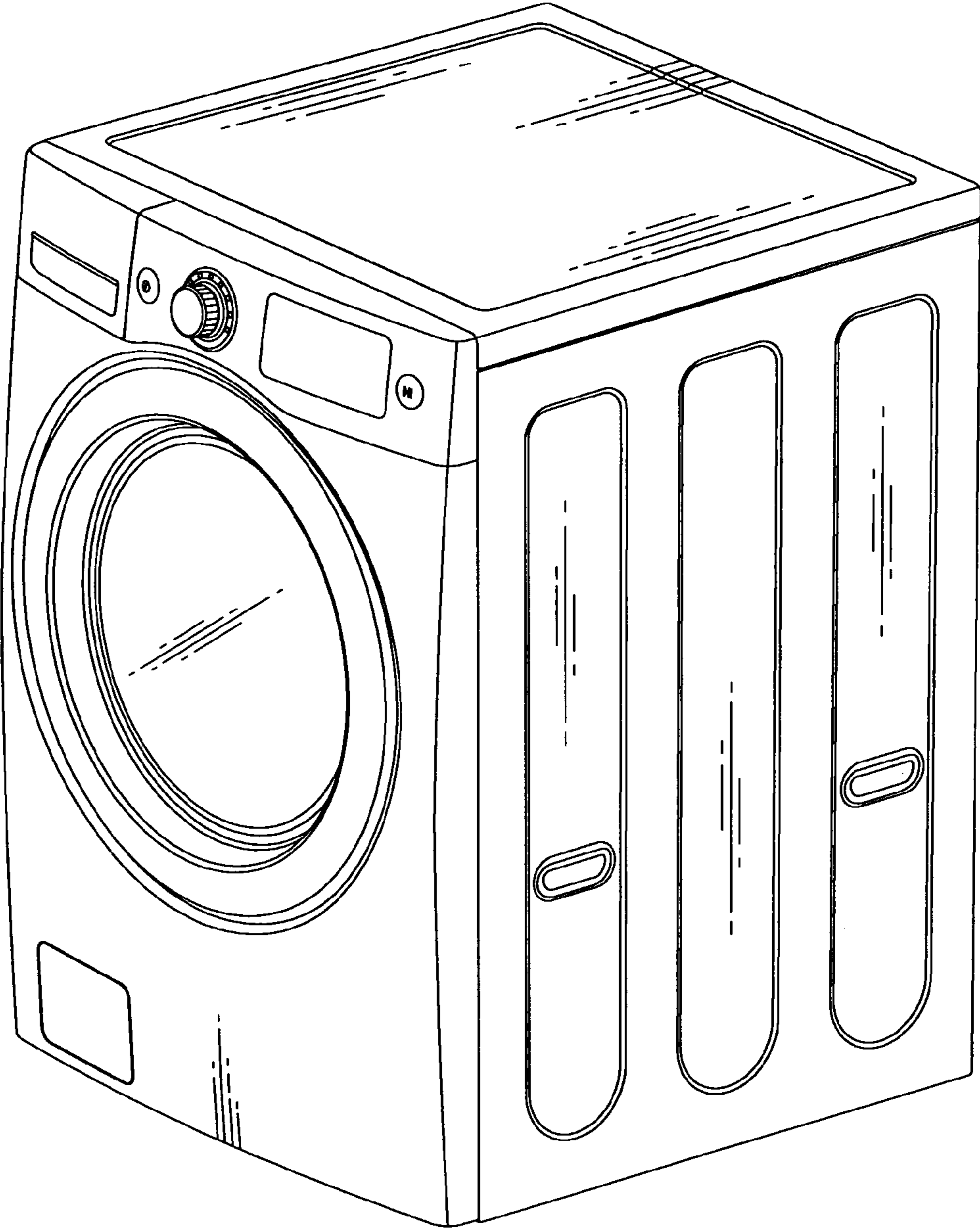

FIG. 2

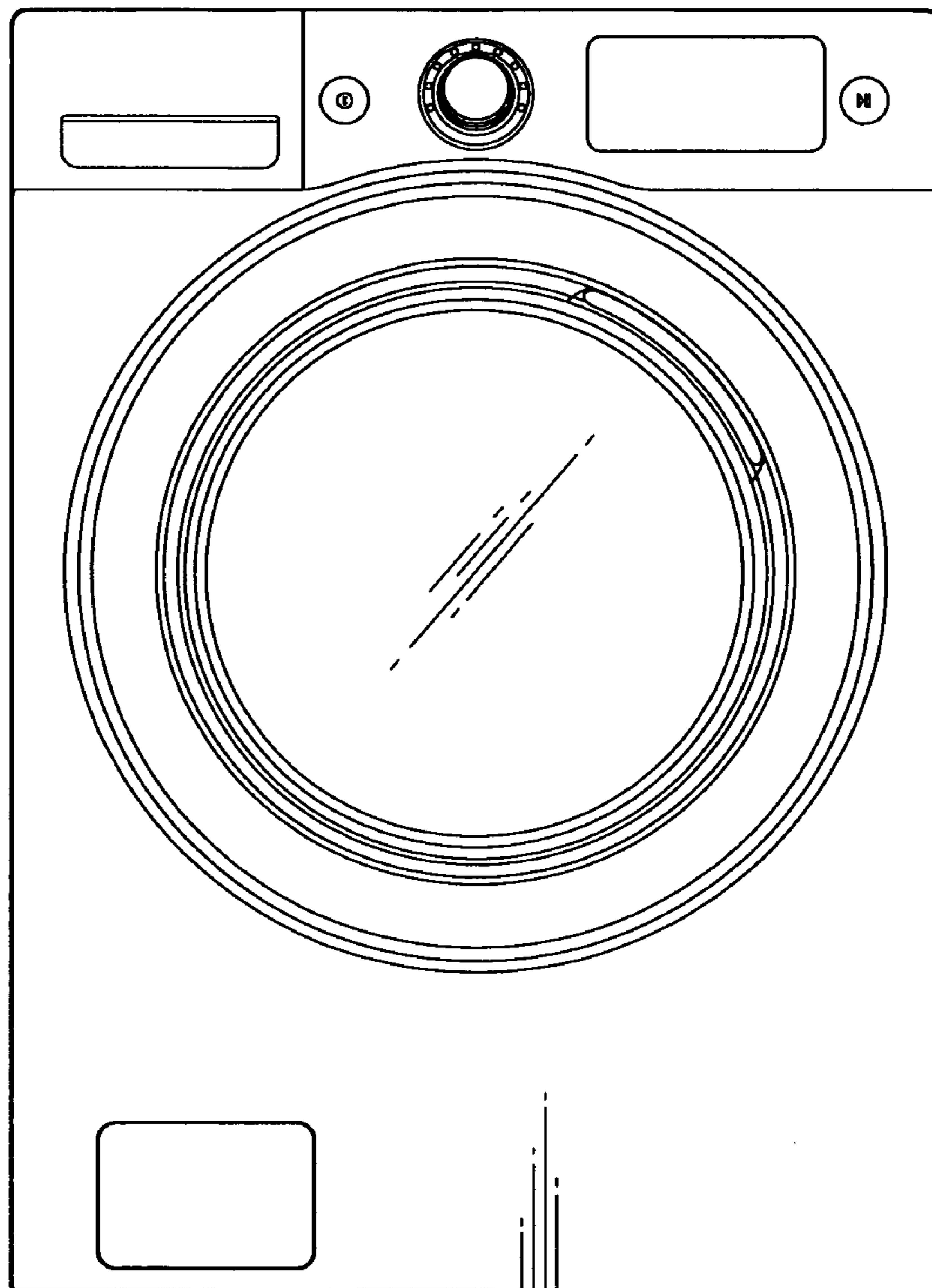

FIG. 3

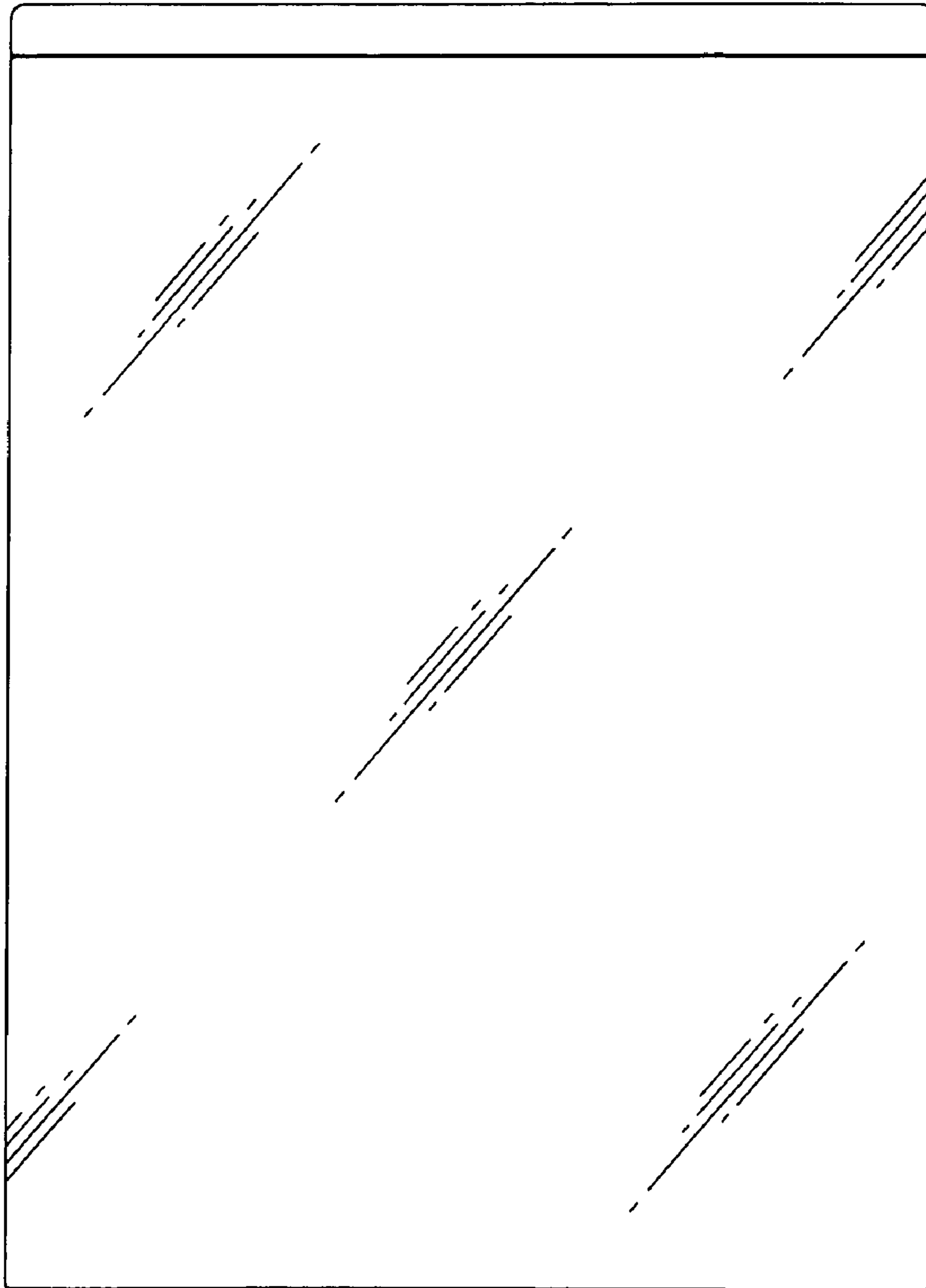

FIG. 4

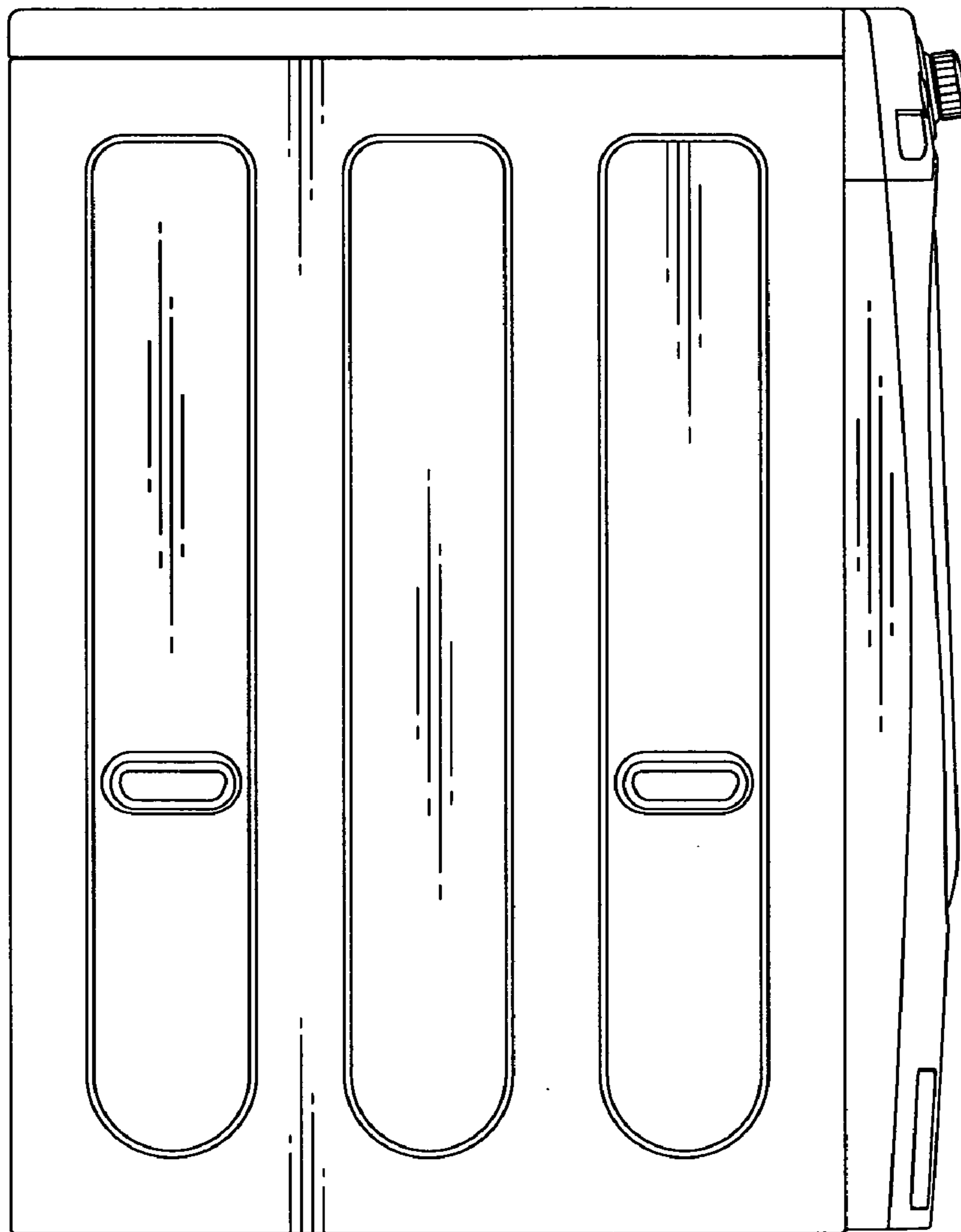

FIG. 5

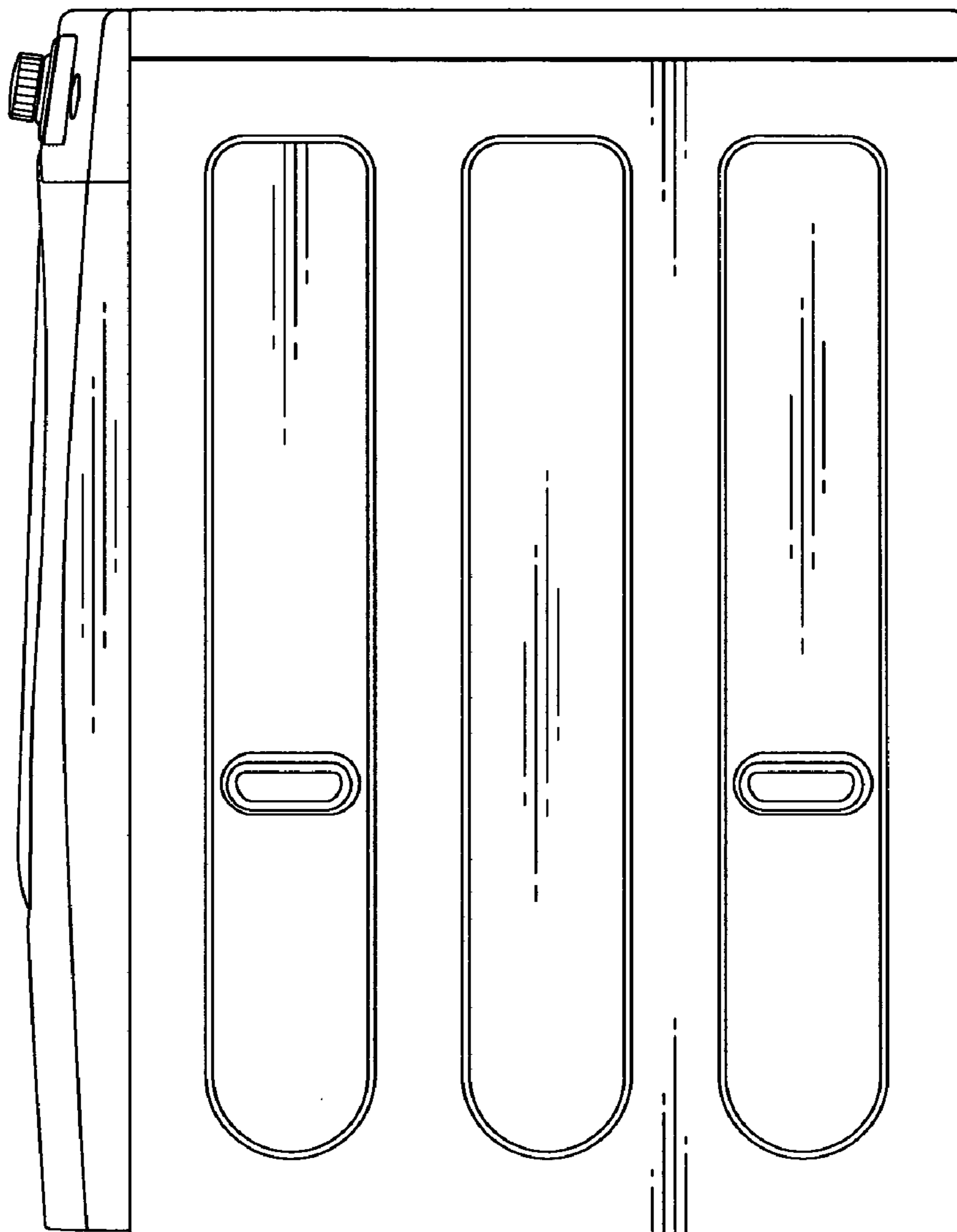

FIG. 6

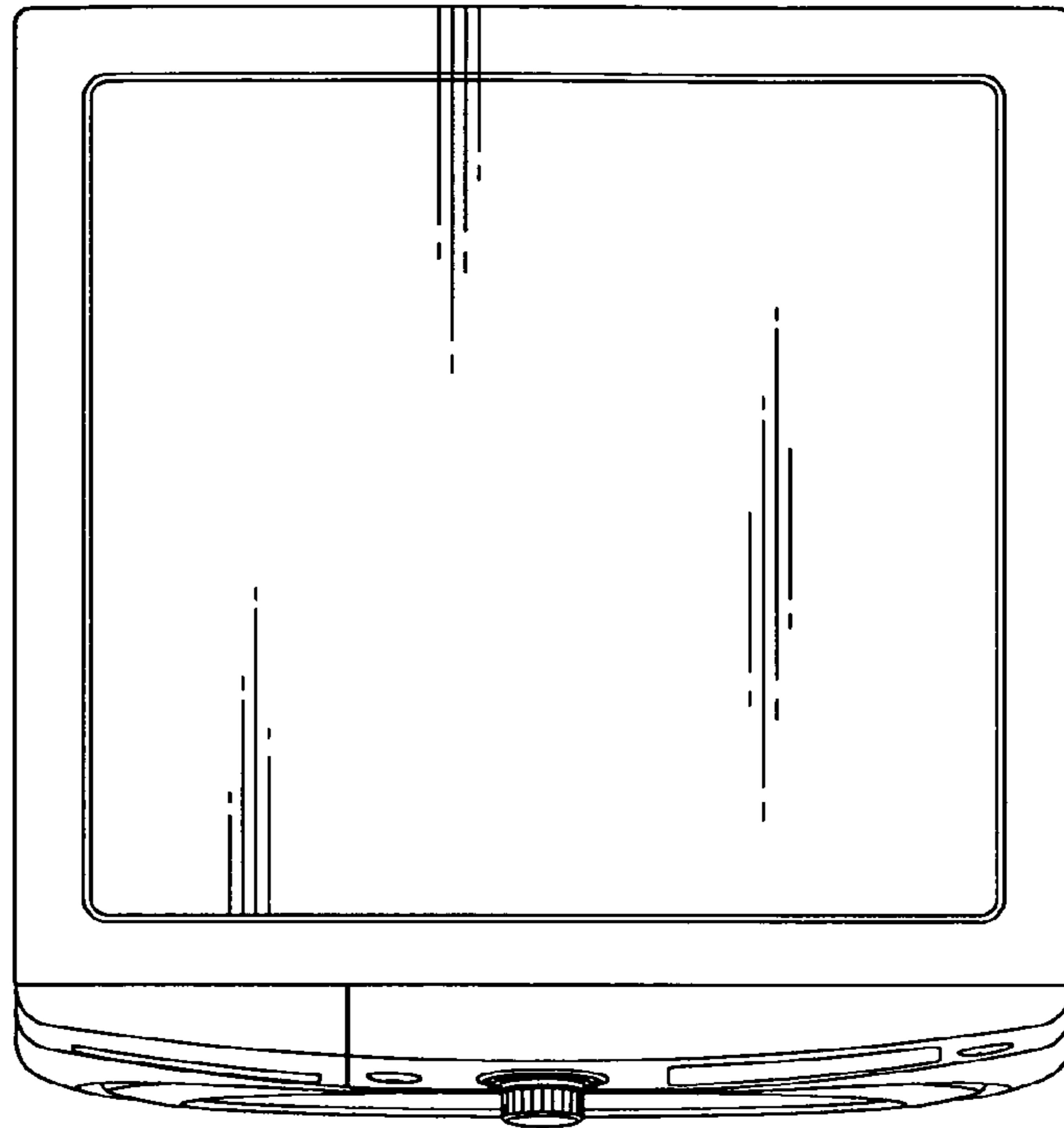

FIG. 7

