



US00D581797S

(12) **United States Design Patent**
Calvo

(10) **Patent No.:** **US D581,797 S**

(45) **Date of Patent:** **** Dec. 2, 2008**

(54) **BOTTLE**

(75) Inventor: **Carles Vila Calvo**, Barcelona (ES)

(73) Assignee: **Fragrance and Skincare S.L.**,
Barcelona (ES)

(**) Term: **14 Years**

(21) Appl. No.: **29/270,447**

(22) Filed: **Dec. 22, 2006**

(30) **Foreign Application Priority Data**

Jun. 26, 2006 (EM) 000550371

(51) **LOC (8) Cl.** **09-01**

(52) **U.S. Cl.** **D9/523; D9/572**

(58) **Field of Classification Search** D9/682-694,
D9/516-575, 436, 447-449; D28/91.1; 215/379;
220/660, 662, 665; 222/372, 373, 383.1,
222/386, 401-402.25

See application file for complete search history.

(56) **References Cited**

U.S. PATENT DOCUMENTS

D60,472 S *	2/1922	Smith	D9/573
D61,829 S *	1/1923	Javal	D9/544
D67,625 S *	6/1925	Terry	D9/544
D76,142 S *	8/1928	Liddell	D9/544
D98,598 S *	2/1936	Kihn	D9/563
D141,775 S *	7/1945	Buckingham	D9/544
3,136,438 A *	6/1964	Marsh	215/12.1
D217,659 S *	5/1970	Dinand	D9/574
D218,281 S *	8/1970	Diener	D9/523
D221,520 S *	8/1971	Plummer	D9/529
D299,429 S *	1/1989	Dinand	D9/566
D379,766 S *	6/1997	Schneider et al.	D9/542
D502,268 S *	2/2005	Sakai et al.	D24/224
6,945,428 B2 *	9/2005	Shimizu et al.	222/105
D512,638 S *	12/2005	Baron	D9/523

D516,917 S *	3/2006	Baron	D9/523
D525,142 S *	7/2006	Baron	D9/682
D531,049 S *	10/2006	De France	D9/686
D536,259 S *	2/2007	Herrmann	D9/573

FOREIGN PATENT DOCUMENTS

WO DM/057017 * 5/2001

OTHER PUBLICATIONS

Bormioli Luigi, Brooks Brothers fragrance, shown in Soap & Cosmetics magazine, Jun. 1999, p. 36.

Tommy Hilfiger, Hilfiger Athletics fragrance, advertisement in Outside magazine, Jun. 1998, p. 21.

* cited by examiner

Primary Examiner—Catherine Tuttle

(74) *Attorney, Agent, or Firm*—Fross Zelnick Lehrman & Zissu, P.C.; Charles T. J. Weigell, Esq.; Lawrence E. Apolzon, Esq.

(57) **CLAIM**

The ornamental design for a bottle, as shown and described.

DESCRIPTION

FIG. 1 is a front perspective view of a bottle showing my new design;

FIG. 2 is a front view of the bottle shown in FIG. 1;

FIG. 3 is a right side view of the bottle shown in FIG. 1;

FIG. 4 is a bottom view of the bottle shown in FIG. 1;

FIG. 5 is a rear view of the bottle shown in FIG. 1;

FIG. 6 is a left side view of the bottle shown in FIG. 1; and,

FIG. 7 is a top view of the bottle shown in FIG. 1.

The broken line showing of the internal compartment of the bottle is for illustrative purposes only and forms no part of the claimed design.

1 Claim, 3 Drawing Sheets

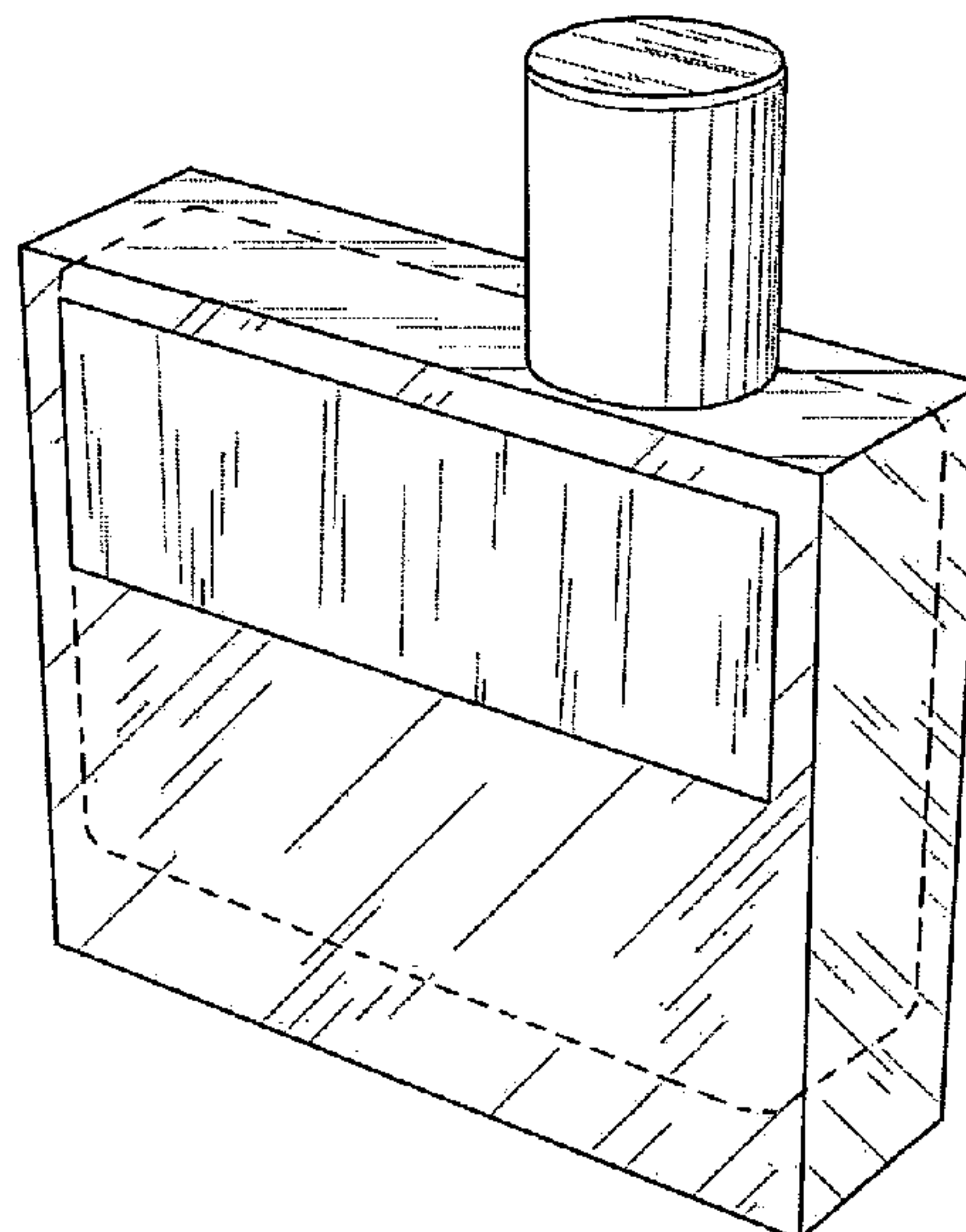

Fig. 1

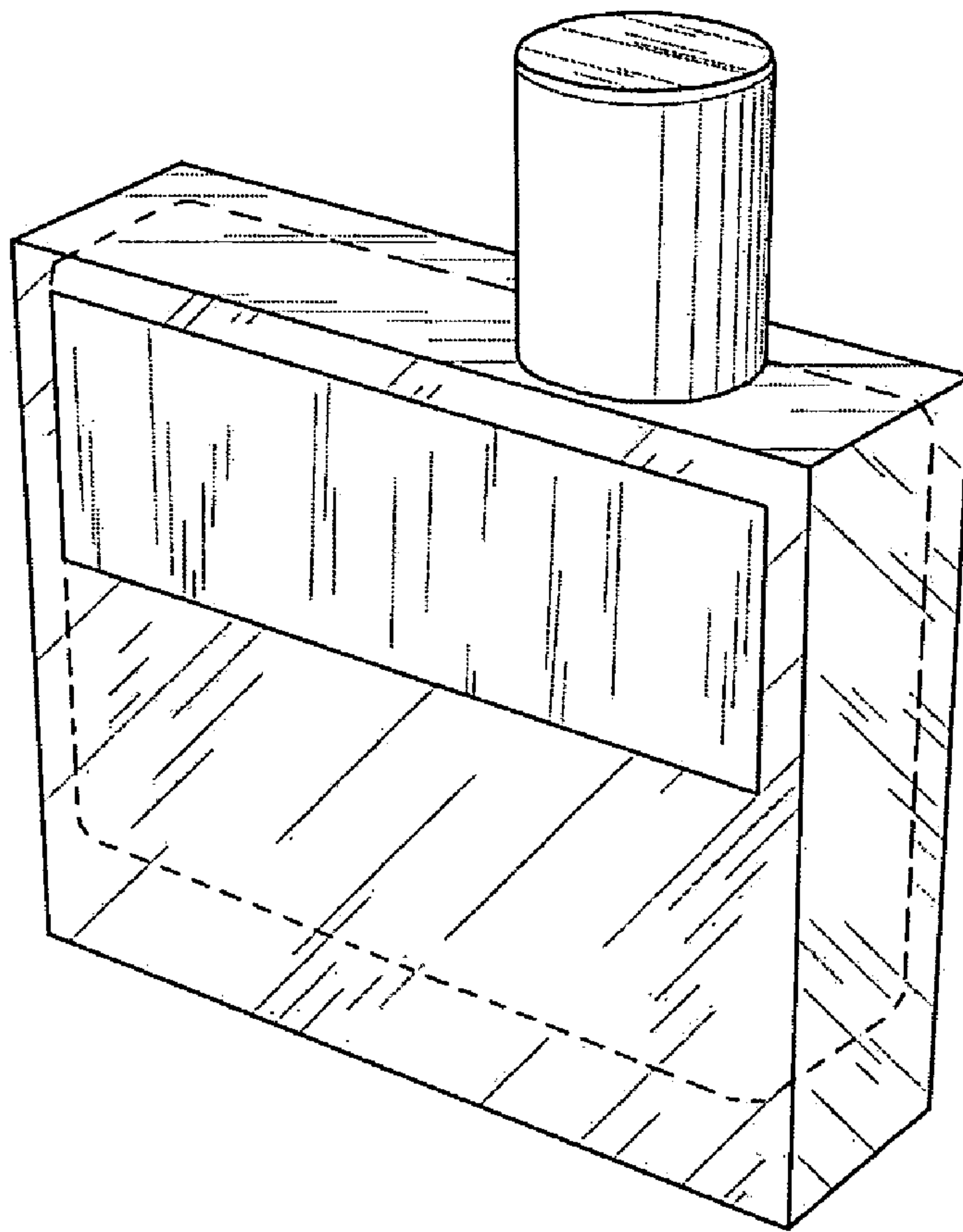

Fig.3

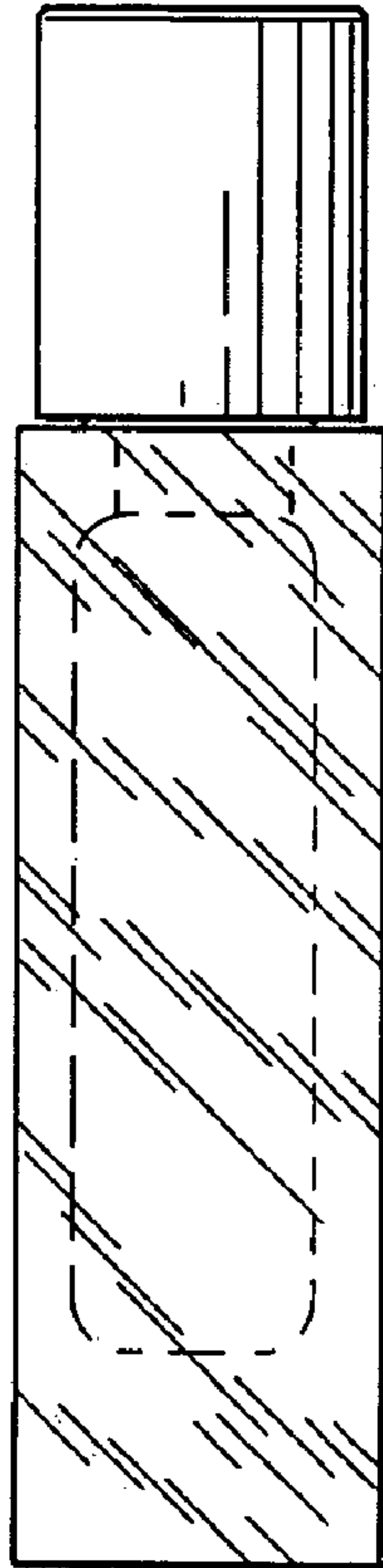

Fig.2

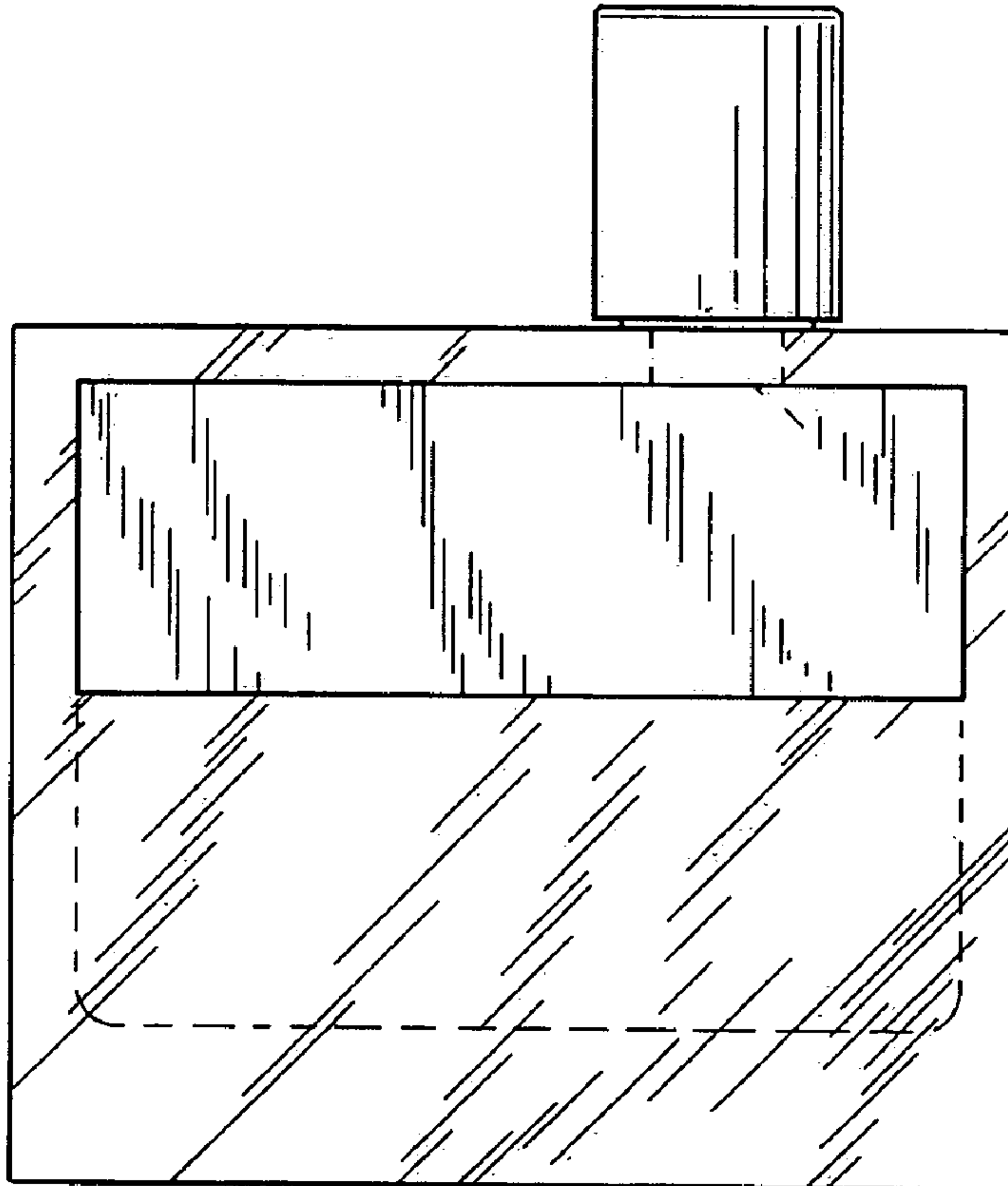

Fig.4

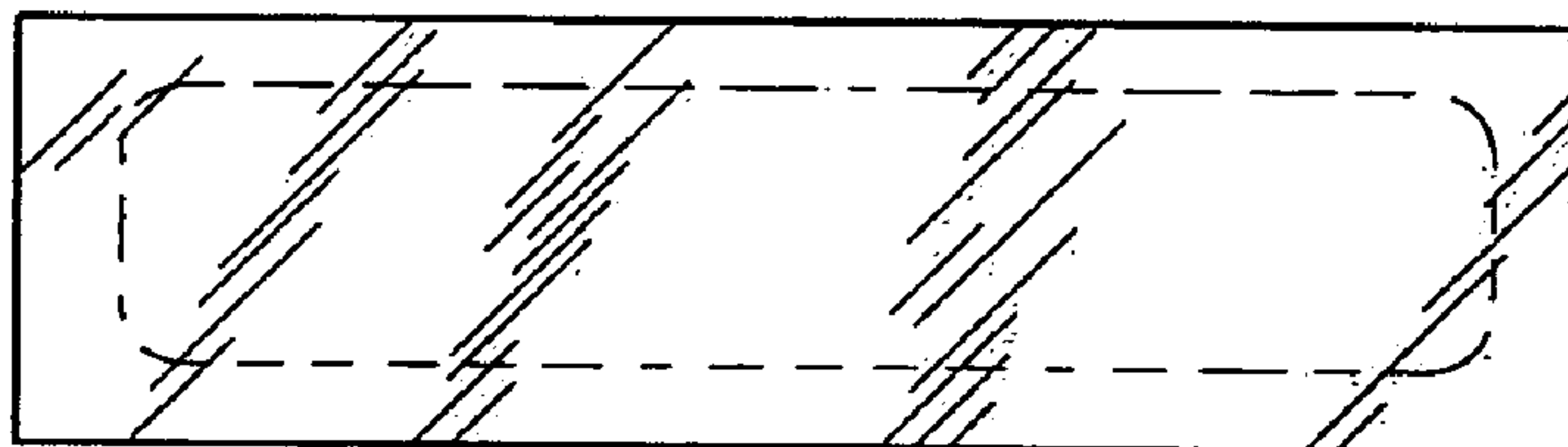

Fig.5

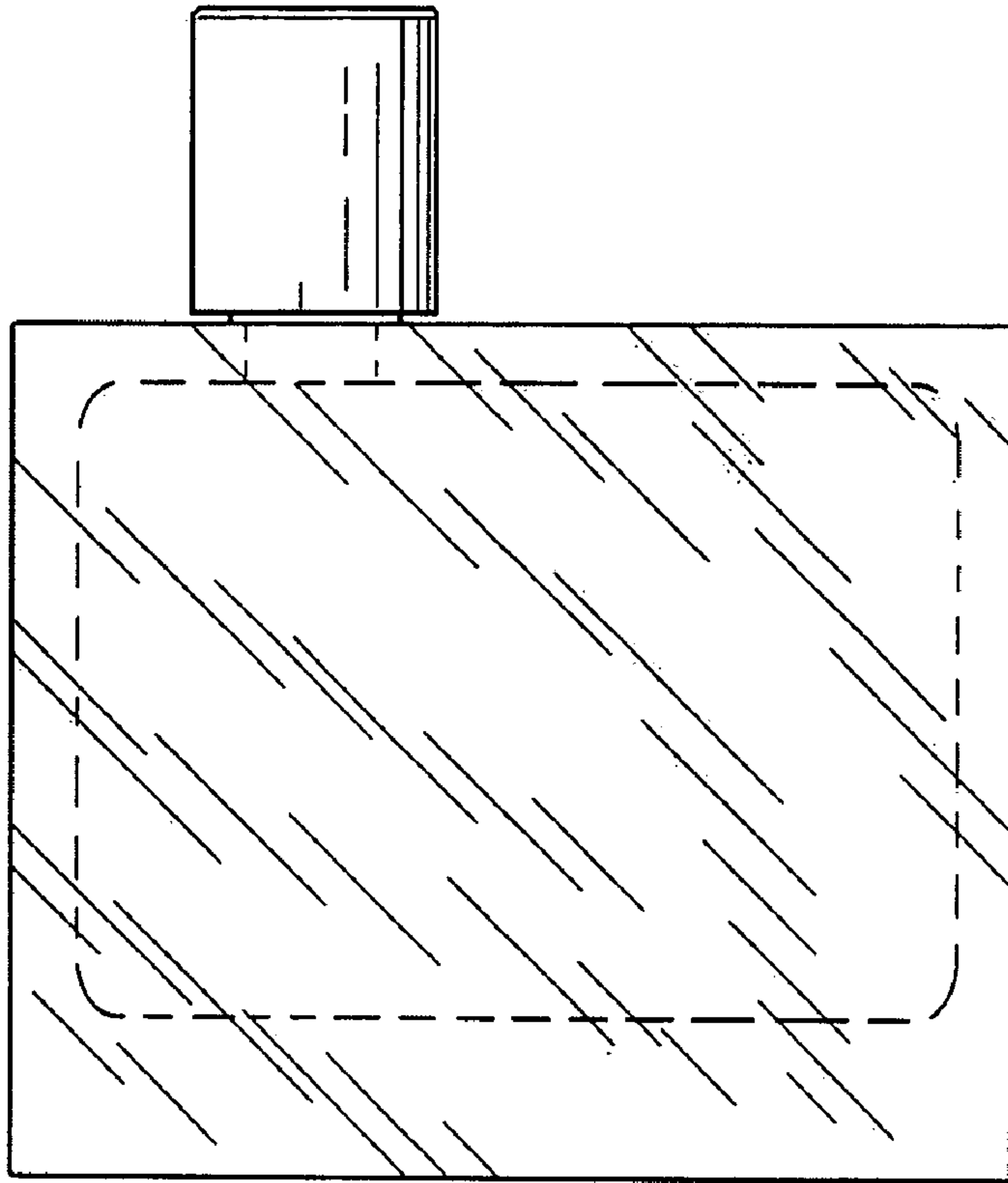

Fig.6



Fig.7

