



US00D581772S

(12) **United States Design Patent**
Hozen

(10) **Patent No.:** **US D581,772 S**

(45) **Date of Patent:** **** Dec. 2, 2008**

(54) **HANDRAIL COUPLING**

6,948,840 B2 9/2005 Grenda et al.
7,011,297 B1 3/2006 Guillot
7,048,412 B2 5/2006 Martin et al.

(76) **Inventor:** **Jim F. Hozen**, 227 Airport Rd. NE.,
Silverton, OR (US) 97381

* cited by examiner

(**) **Term:** **14 Years**

Primary Examiner—Holly H. Baynham

Assistant Examiner—Sheryl Lane

(21) **Appl. No.:** **29/250,021**

(74) *Attorney, Agent, or Firm*—Dennis T. Griggs

(22) **Filed:** **Oct. 31, 2006**

(57) **CLAIM**

(51) **LOC (8) Cl.** **08-08**

The ornamental design for a handrail coupling, as shown and described.

(52) **U.S. Cl.** **D8/382**

(58) **Field of Classification Search** **D8/382**

See application file for complete search history.

DESCRIPTION

(56) **References Cited**

FIG. 1 is a top plan view of a double-ended handrail coupling showing my new design;

U.S. PATENT DOCUMENTS

FIG. 2 is a bottom plan view thereof;

3,057,991	A	10/1962	Grenadier	
3,740,541	A	6/1973	Conradt	
4,161,769	A	7/1979	Elliott	
4,367,517	A	1/1983	Balzer	
4,394,714	A	7/1983	Rote	
5,099,402	A	3/1992	Starniri	
5,370,368	A *	12/1994	Terrels et al.	256/19
5,450,299	A	9/1995	Lepre	
5,701,236	A	12/1997	Viviano	
5,779,228	A	7/1998	Hansen	
5,803,647	A *	9/1998	Hughes	403/306
6,045,240	A	4/2000	Hochstein	
6,065,250	A *	5/2000	McCabe	52/27
6,065,852	A	5/2000	Crumley	
6,173,517	B1	1/2001	Eibner	
6,415,732	B1	7/2002	Delorenzo	
6,425,676	B1	7/2002	Lyons	
6,481,874	B2	11/2002	Petroski	
6,492,725	B1	12/2002	Loh et al.	
6,517,218	B2	2/2003	Hochstein	
6,568,658	B2 *	5/2003	Strome	256/65.14
6,637,924	B2	10/2003	Pelka et al.	
6,827,468	B2	12/2004	Galli	
6,866,125	B2	3/2005	Ball et al.	
6,897,486	B2	5/2005	Loh	
6,916,103	B2	7/2005	Currie et al.	

FIG. 3 is a front side elevational view thereof, the rear side elevational view being a mirror image thereof;

FIG. 4 is a right end elevational view thereof, the left end elevational view being a mirror image thereof;

FIG. 5 is a perspective view thereof;

FIG. 6 is a top plan view of an alternative embodiment of a double-ended handrail coupling showing my new design;

FIG. 7 is a bottom plan view thereof;

FIG. 8 is a front side elevational view thereof, the rear side elevational view being a mirror image thereof;

FIG. 9 is a right end elevational view thereof, the left end elevational view being a mirror image thereof; and,

FIG. 10 is a perspective view thereof.

The dashed lines shown in FIG. 5 and FIG. 10 represent environmental subject matter and form no part of the claimed design.

The dotted lines shown in FIG. 4, FIG. 5, FIG. 9 and FIG. 10 represent boundaries between claimed and unclaimed subject matter and form no part of the claimed design.

1 Claim, 6 Drawing Sheets

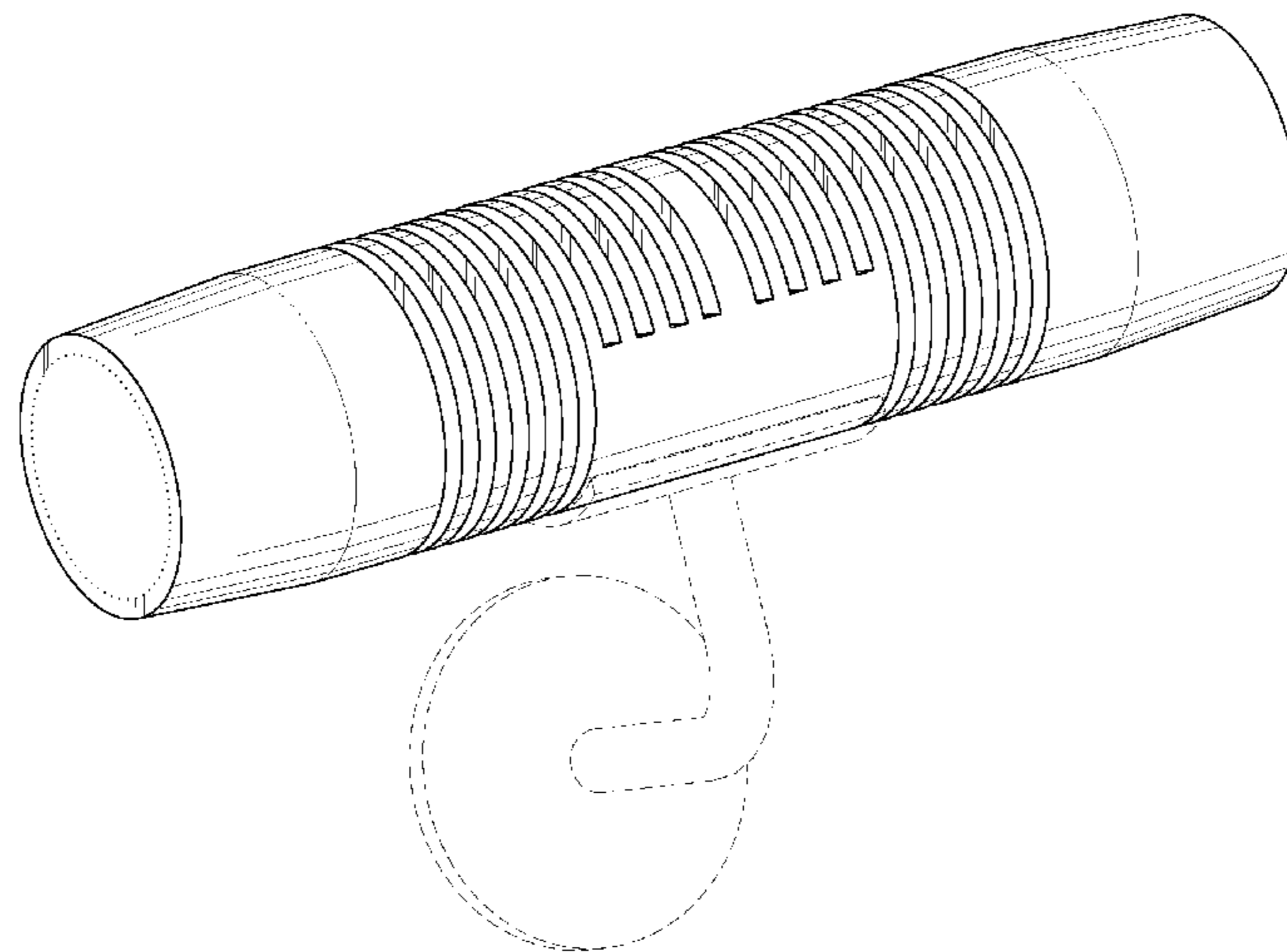

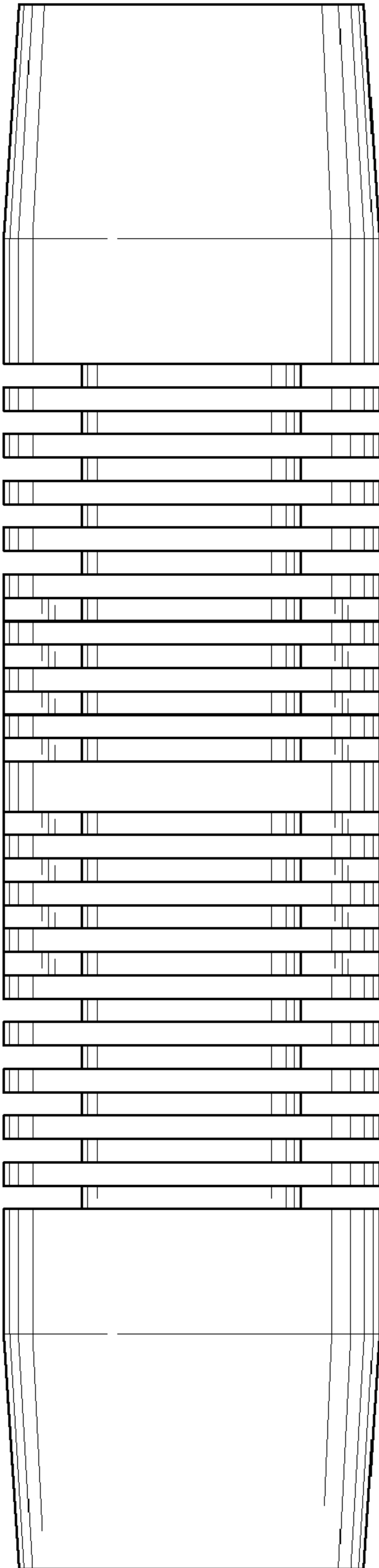

FIG. 1

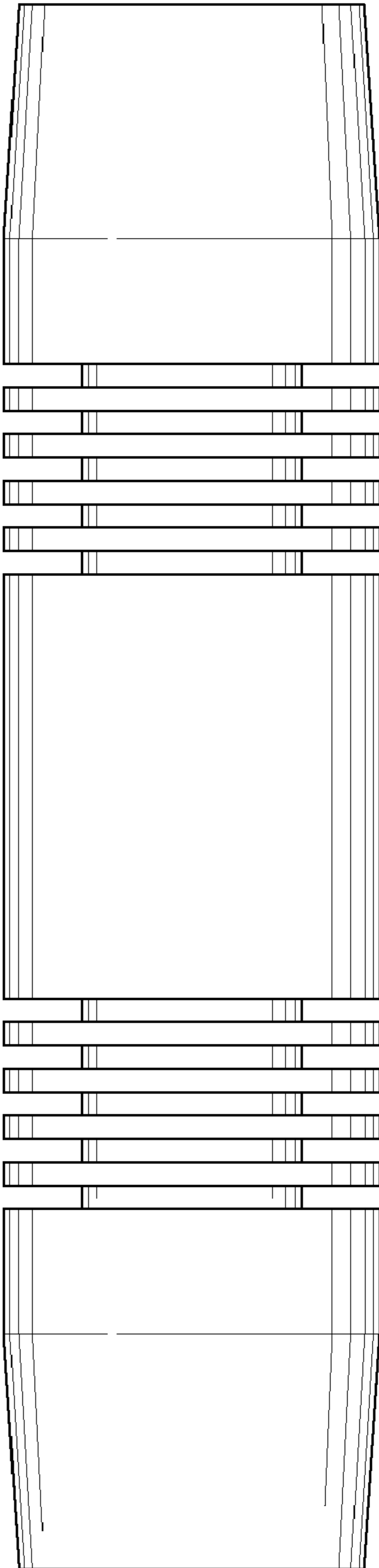

FIG. 2

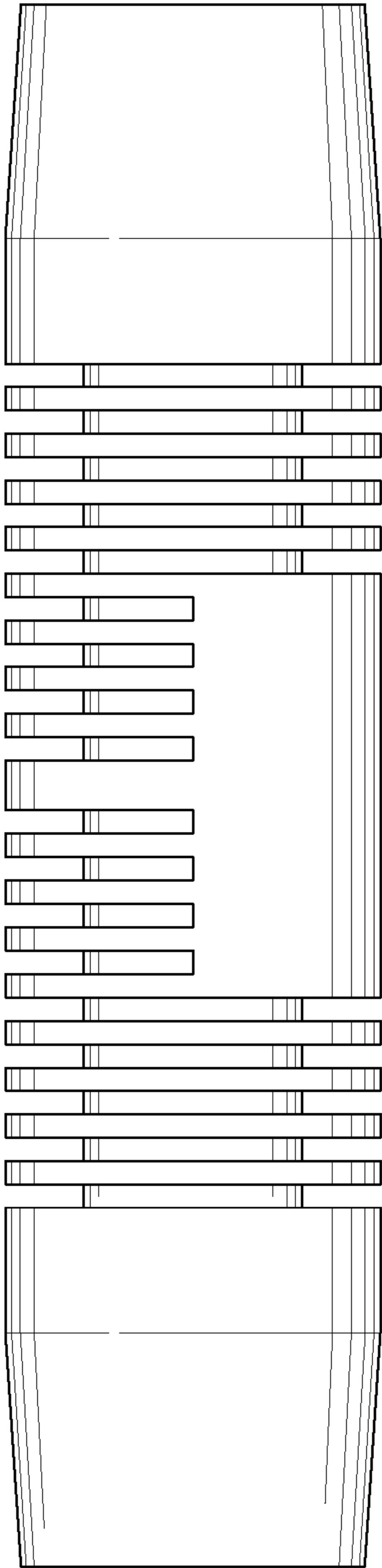

FIG. 3

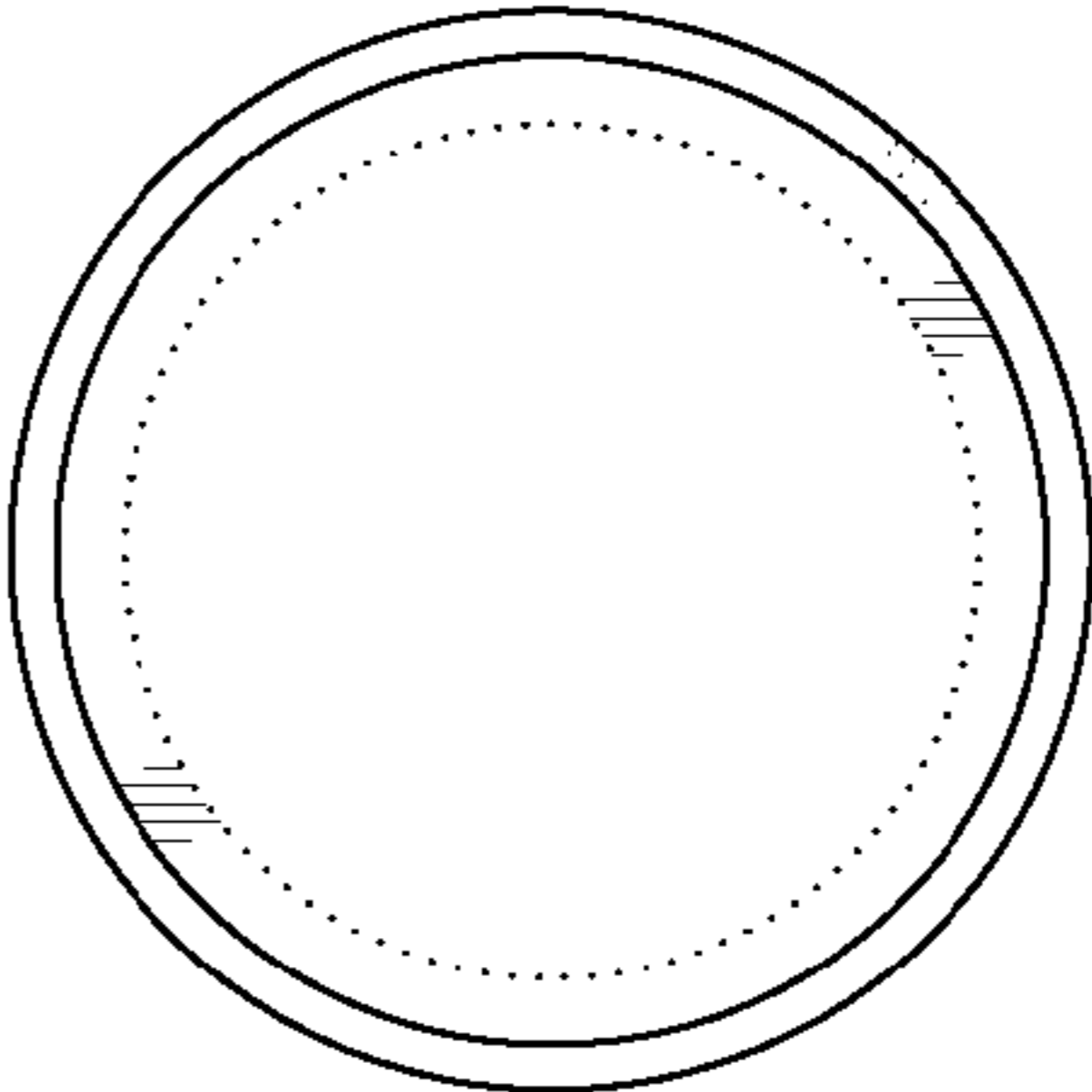

FIG. 4

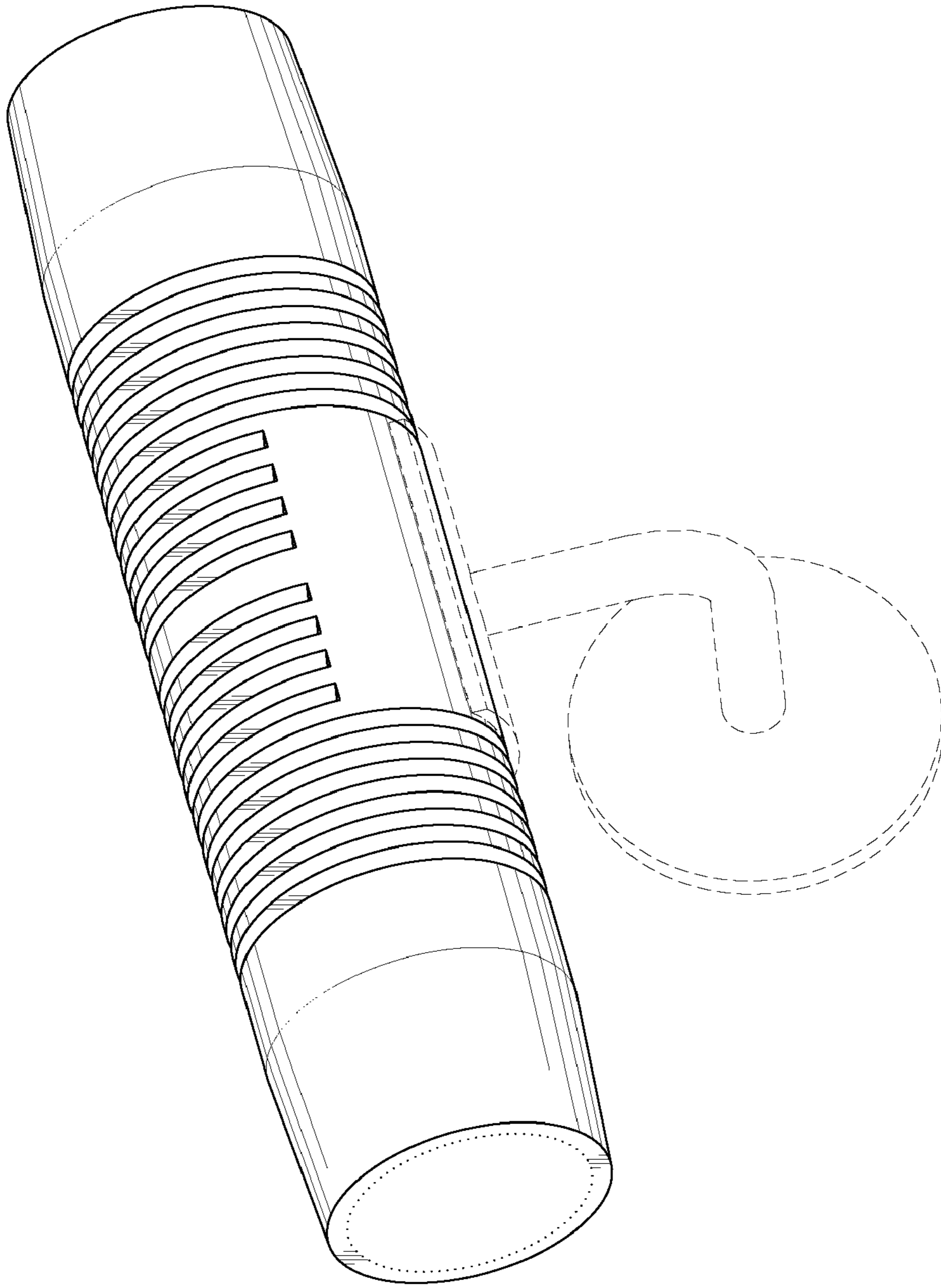

FIG. 5

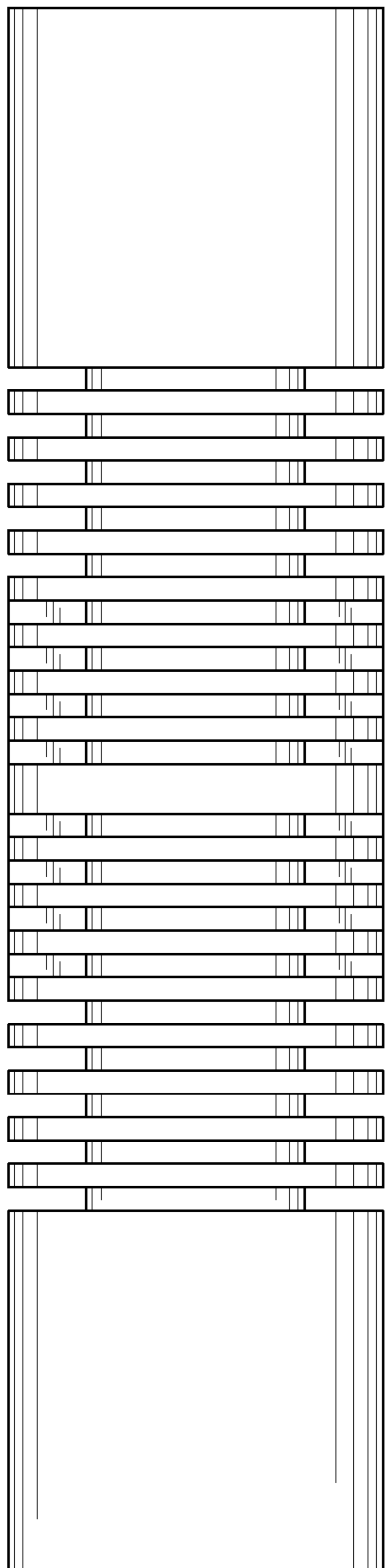

FIG. 6

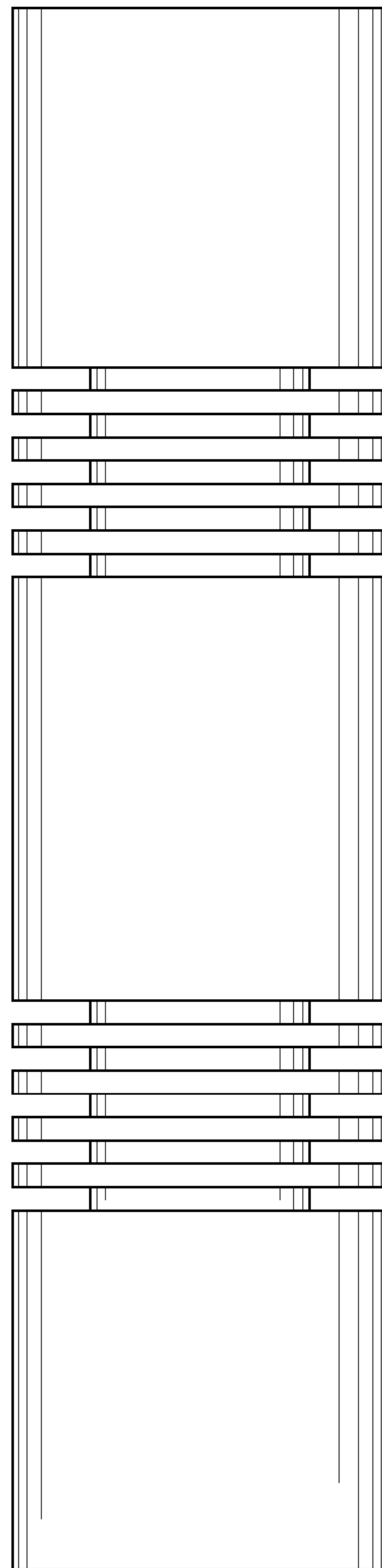

FIG. 7

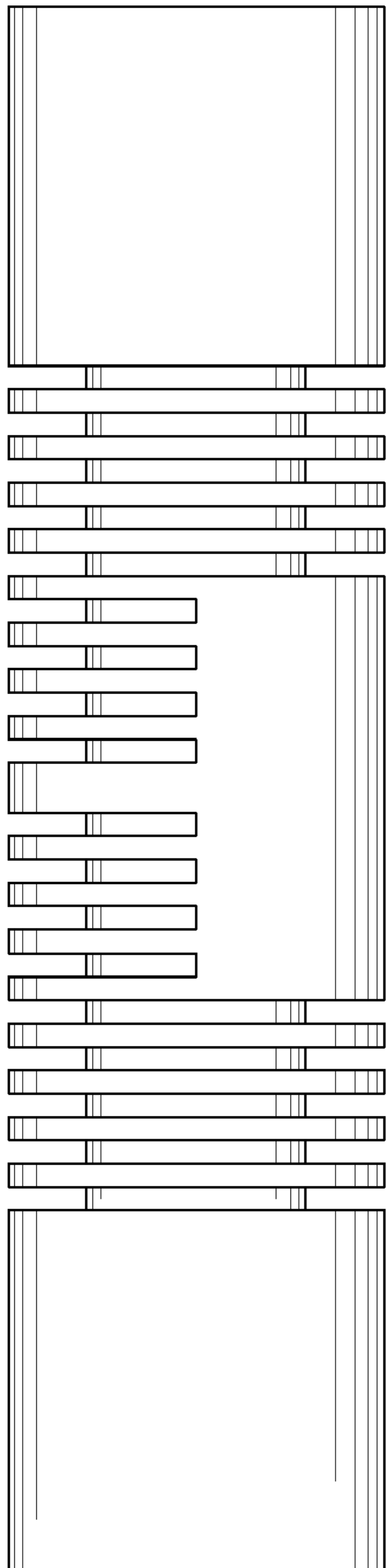

FIG. 8

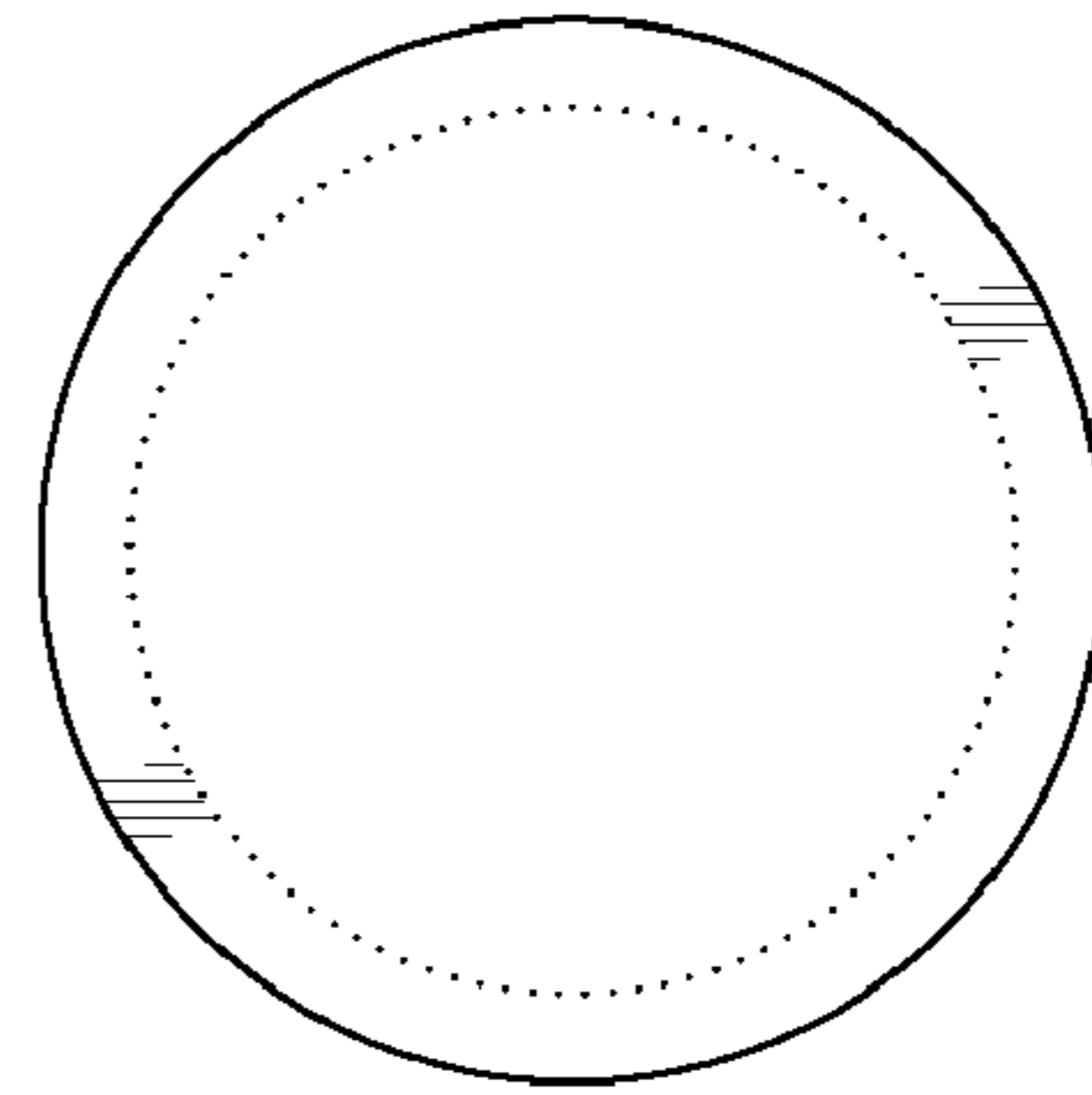

FIG. 9

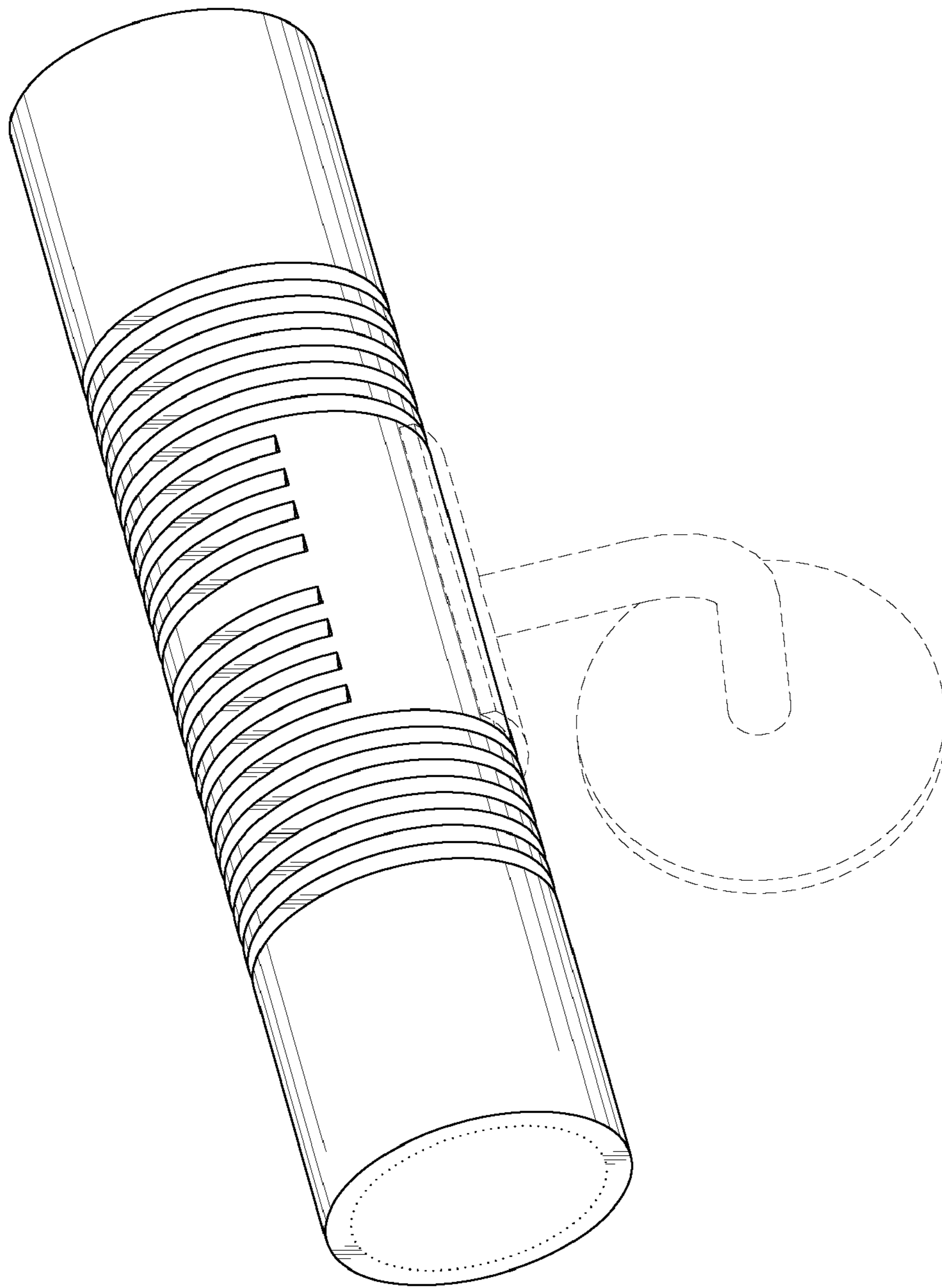

FIG. 10