



US00D581763S

(12) **United States Design Patent**  
**Post**

(10) **Patent No.:** **US D581,763 S**  
(45) **Date of Patent:** **\*\* Dec. 2, 2008**

(54) **ADJUSTMENT RING**

(76) Inventor: **Joseph Post**, 8070 Ridgeway Dr.,  
Burlington, WI (US) 53105

(\*\*) Term: **14 Years**

(21) Appl. No.: **29/301,482**

(22) Filed: **Mar. 4, 2008**

(51) **LOC (8) Cl.** ..... **08-05**

(52) **U.S. Cl.** ..... **D8/70**

(58) **Field of Classification Search** ..... D8/61,  
D8/62, 70, 396, 397, 399; D16/132; D22/109;  
D23/226, 262; D32/25; 239/301, 432; 411/11,  
411/120, 134, 155, 179, 180, 181, 302, 304,  
411/427, 436, 533, 542

See application file for complete search history.

(56) **References Cited**

**U.S. PATENT DOCUMENTS**

D44,178 S *	6/1913	McMurtrie	.....	D23/262
D273,561 S *	4/1984	Ozaki et al.	.....	D8/397
D288,902 S *	3/1987	Lewis	.....	D8/397
D308,982 S *	7/1990	Moore	.....	D16/132
D413,153 S *	8/1999	Tucker	.....	D22/109
6,036,109 A *	3/2000	DeYoung	.....	239/301
D427,658 S *	7/2000	Tucker	.....	D22/109
D439,819 S *	4/2001	Bass et al.	.....	D8/70
D441,436 S *	5/2001	Chao	.....	D23/262

D457,604 S *	5/2002	Chen	.....	D23/262
D494,056 S *	8/2004	Clendenning	.....	D8/399
D561,019 S *	2/2008	Riedel et al.	.....	D8/397
2006/0266850 A1 *	11/2006	Weinberger et al.	.....	239/432

\* cited by examiner

*Primary Examiner*—Holly H Baynham

*Assistant Examiner*—Cynthia M Chin

(74) *Attorney, Agent, or Firm*—Ryan Kromholz & Manion  
S.C.

(57) **CLAIM**

The ornamental design for an adjustment ring, as shown and described.

**DESCRIPTION**

FIG. 1 is a top perspective view an adjustment ring according to the present invention.

FIG. 2 is a bottom perspective view of the adjustment ring of FIG. 1.

FIG. 3 is a top plan view of the adjustment ring of FIG. 1.

FIG. 4 is a right side view of the adjustment ring of FIG. 1, with the left side view being a mirror image thereof; and,

FIG. 5 is a bottom plan view of the adjustment ring of FIG. 1.

The broken lines shown in FIGS. 1–5 showing an attached driver are for environmental purposes only and form no part of the present invention.

**1 Claim, 2 Drawing Sheets**

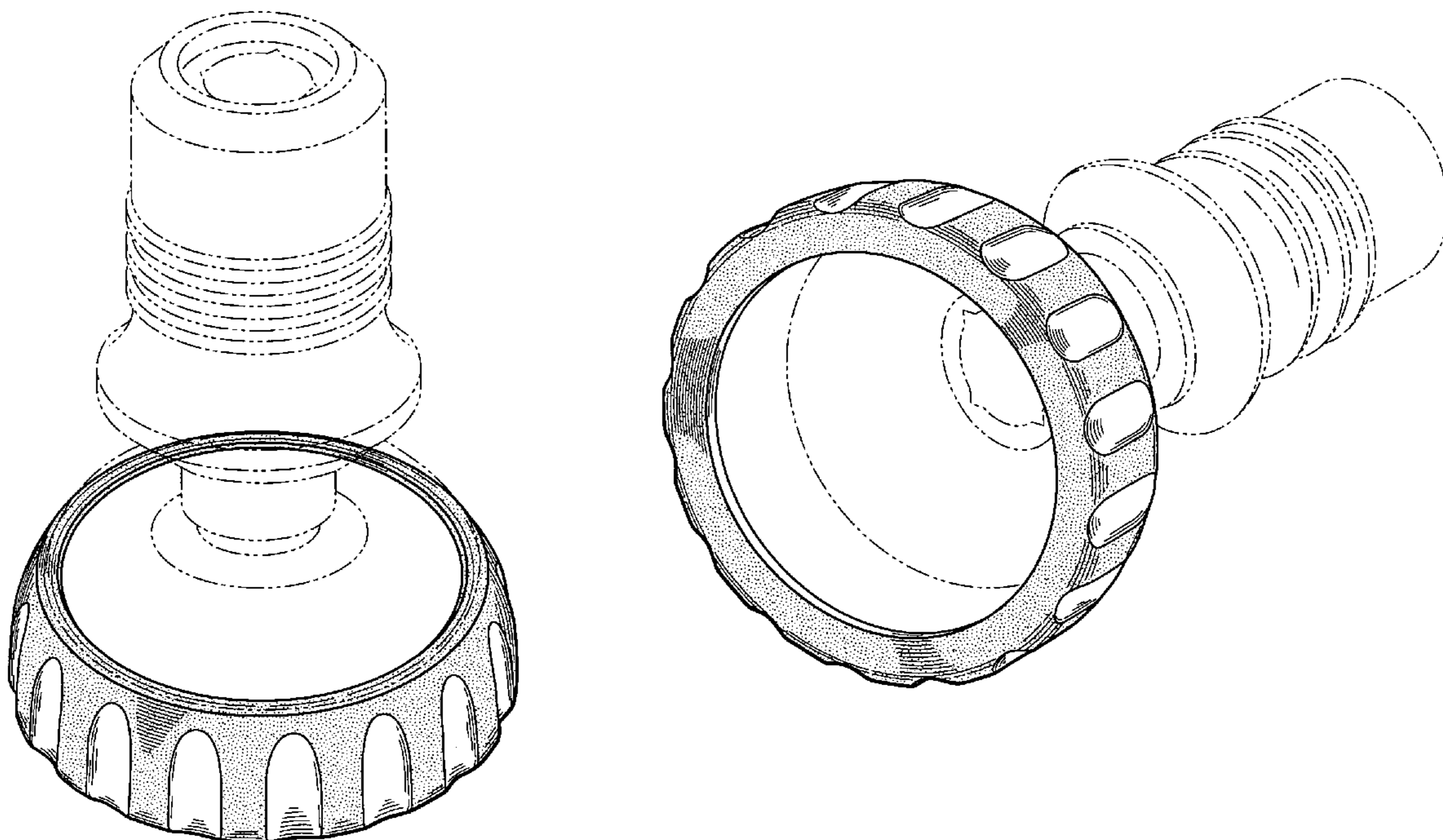

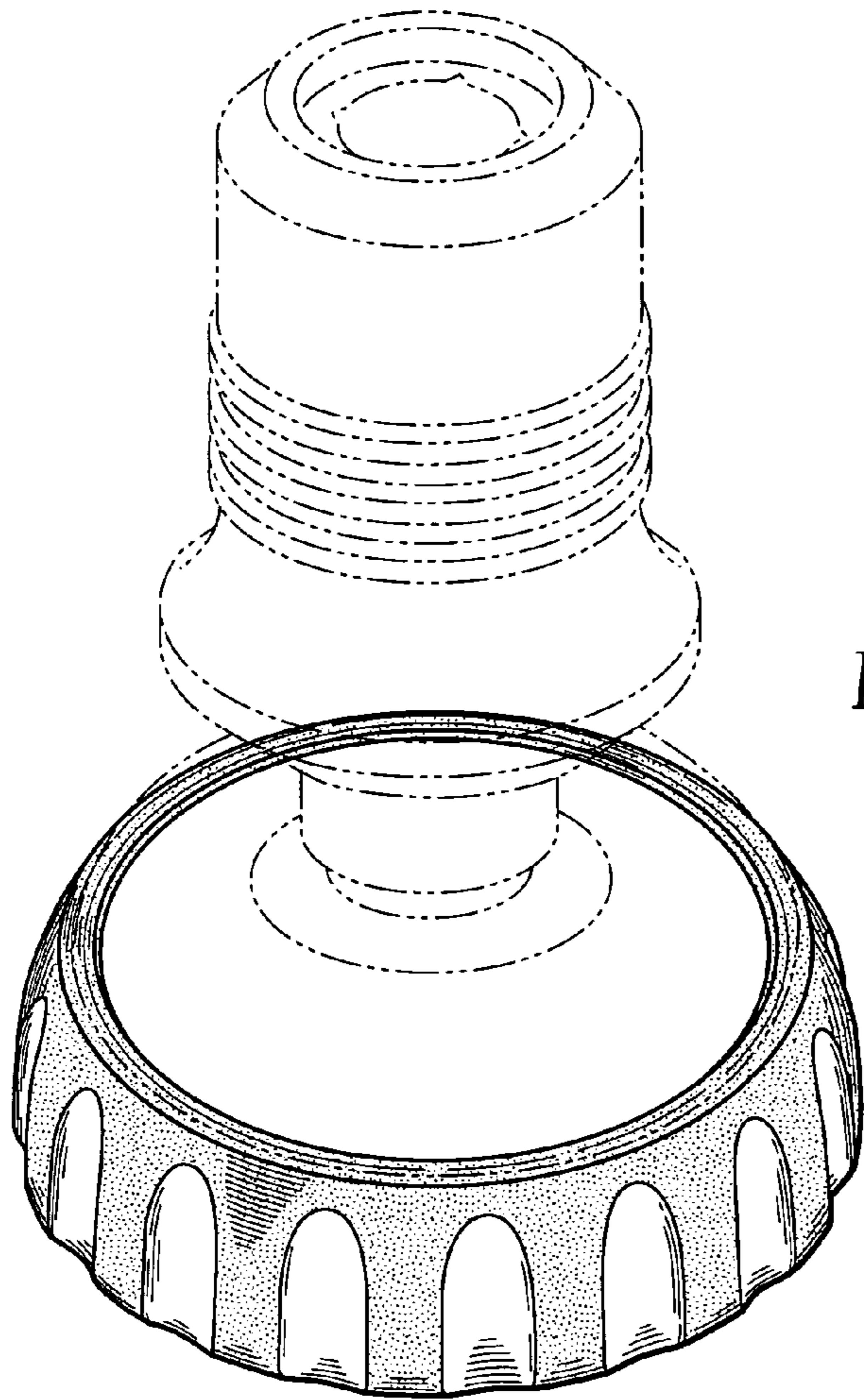

Fig. 1

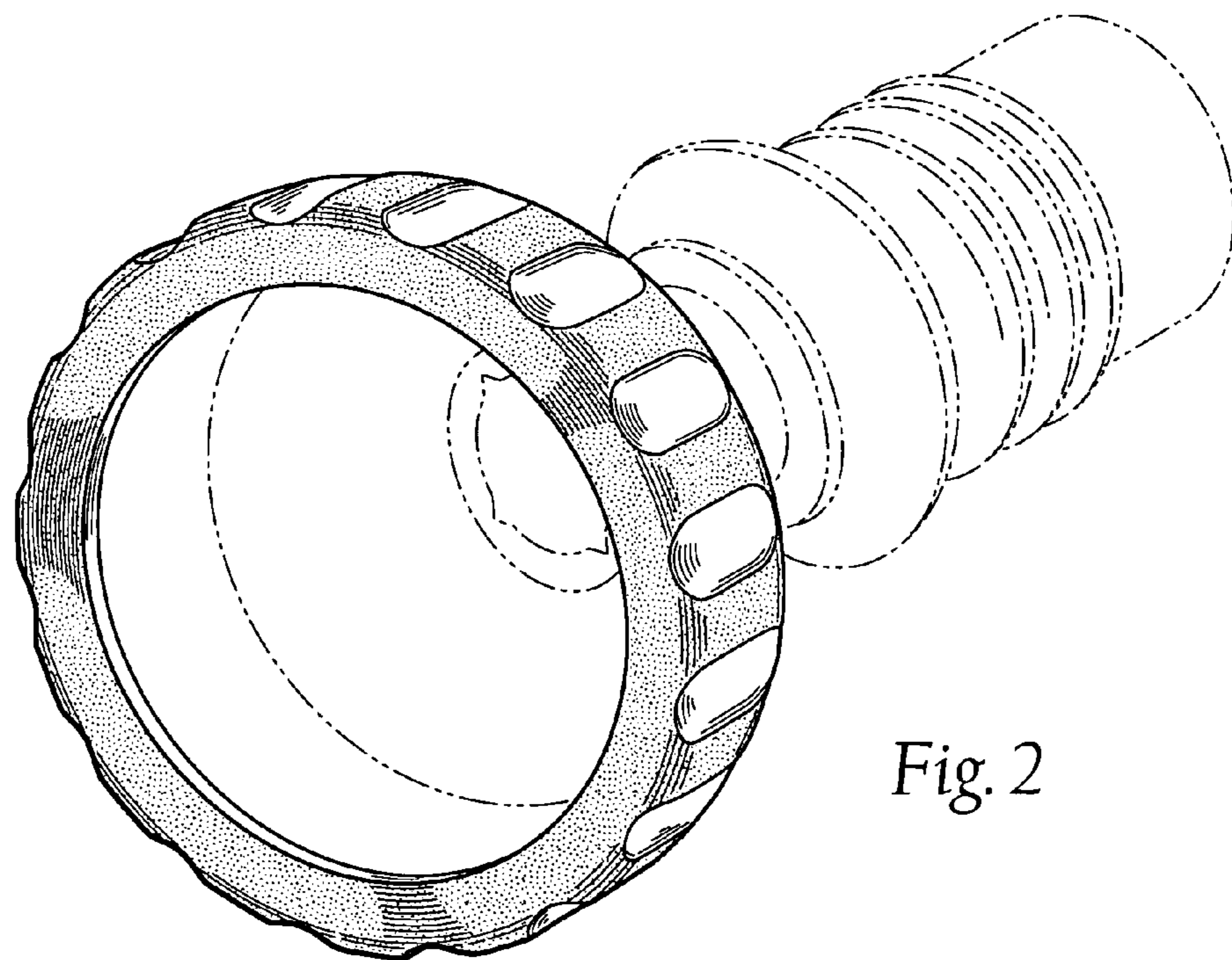

Fig. 2



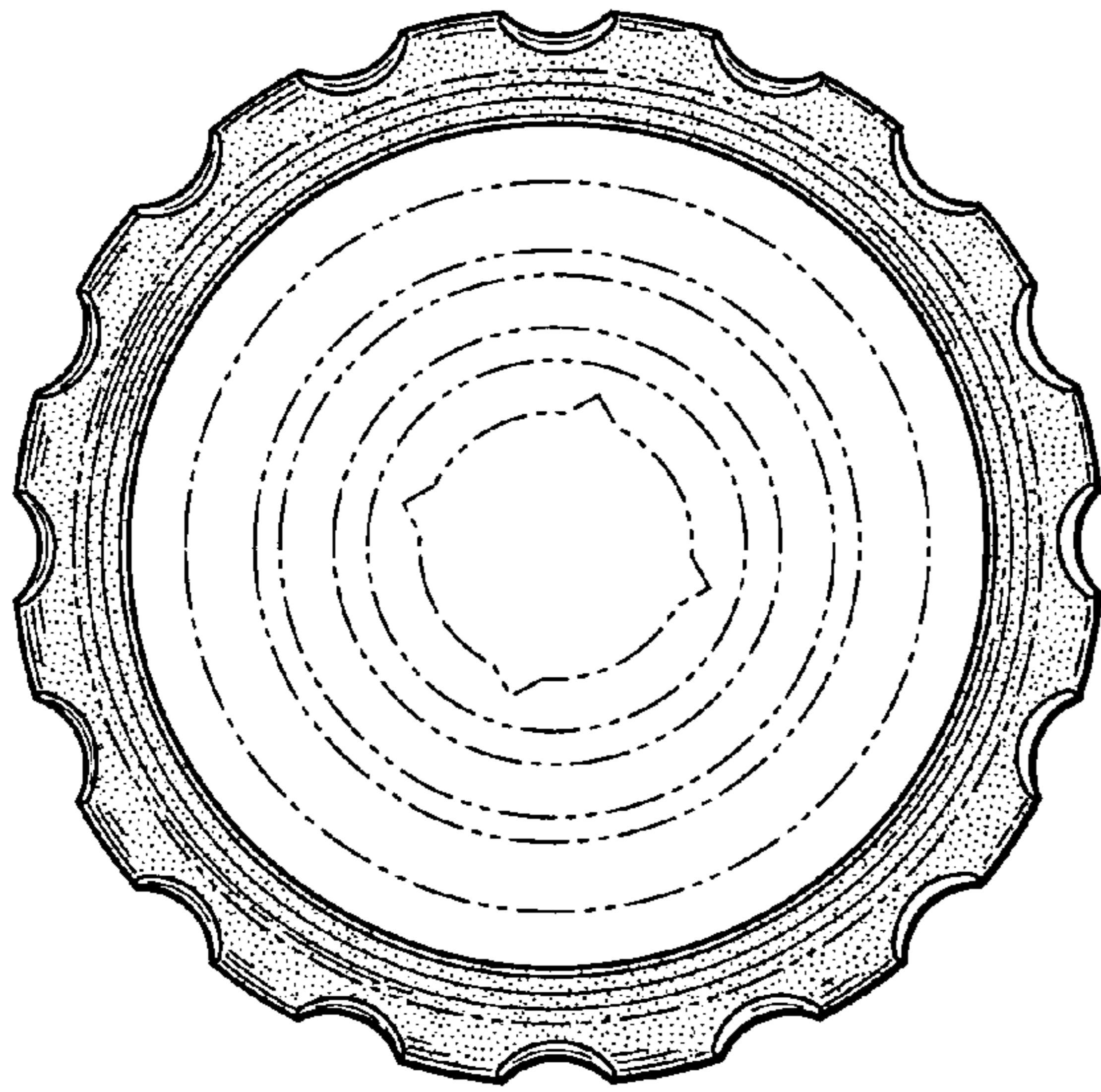

Fig. 3

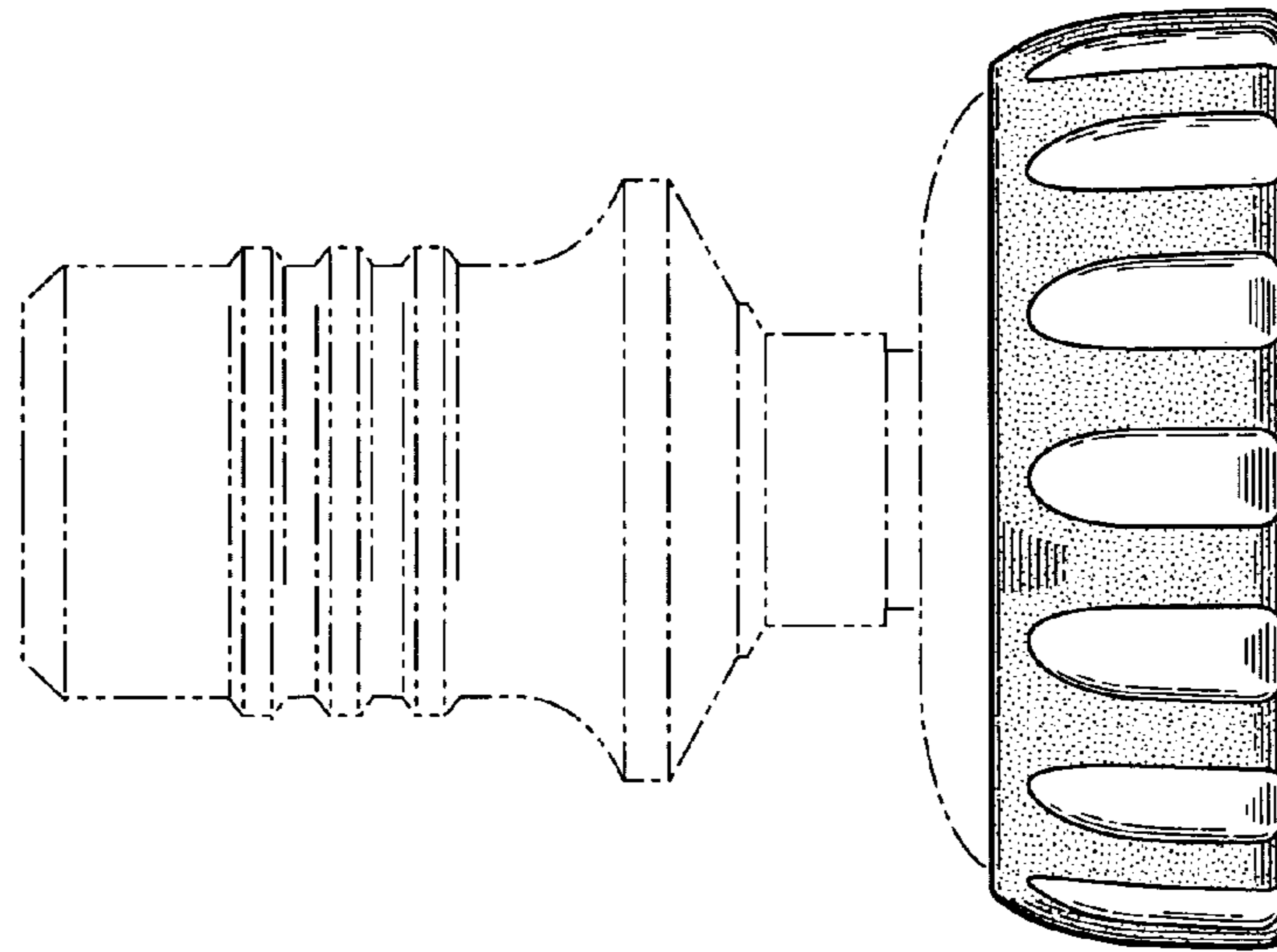

Fig. 4

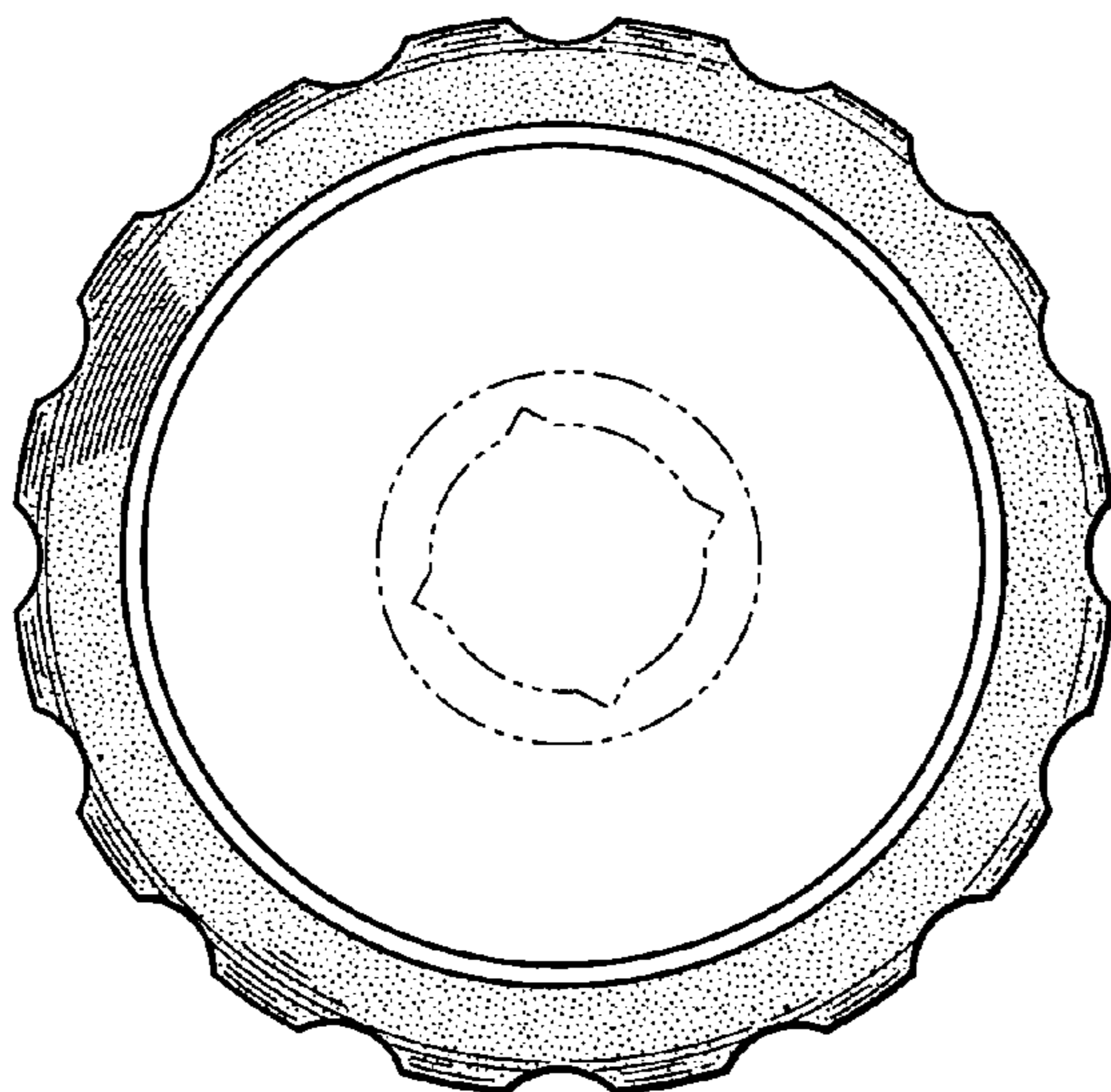

Fig. 5