



US00D581724S

(12) **United States Design Patent**  
**Pan**

(10) **Patent No.:** **US D581,724 S**  
(45) **Date of Patent:** **\*\* Dec. 2, 2008**

(54) **INLET BAFFLE FOR A FOOD WASTE DISPOSAL UNIT**

(75) Inventor: **Ji Cheng Pan**, Tai Po (HK)

(73) Assignee: **Johnson Electric S.A.**, La Chaux-de-Fonds (CH)

(\*\*) Term: **14 Years**

(21) Appl. No.: **29/261,727**

(22) Filed: **Jun. 20, 2006**

(51) **LOC (8) Cl.** ..... **31-00**

(52) **U.S. Cl.** ..... **D7/375; D23/261**

(58) **Field of Classification Search** ..... D23/261;  
D7/375, 372; 4/DIG. 4, 629, 292, 652; 241/46.016,  
241/81, 46.013–46.015, 46.018

See application file for complete search history.

(56) **References Cited**

U.S. PATENT DOCUMENTS

D58,046	S	*	5/1921	Smith	.....	D7/414
2,793,373	A	*	5/1957	Ewing	.....	241/46.016
2,857,109	A	*	10/1958	Haeussler	.....	241/46.015
3,432,108	A		3/1969	Enright		
3,524,596	A		8/1970	Smith		
4,171,103	A	*	10/1979	Rossler	.....	241/152.2
4,199,110	A	*	4/1980	Eriksson	.....	241/20
4,216,918	A	*	8/1980	Kahmann et al.	.....	241/46.017
5,531,385	A	*	7/1996	Witsken	.....	241/21

5,593,098	A	*	1/1997	Spencer et al.	.....	241/46.01
6,719,228	B2		4/2004	Berger et al.		
D539,078	S	*	3/2007	Anderson et al.	.....	D7/375
2004/0195409	A1		10/2004	Berger et al.		
2007/0152087	A1*		7/2007	Pan	.....	241/46.016

FOREIGN PATENT DOCUMENTS

GB 2 392 636 3/2004

\* cited by examiner

*Primary Examiner*—Louis S Zarfaz

*Assistant Examiner*—Eric L Goodman

(74) *Attorney, Agent, or Firm*—Young & Thompson

(57) **CLAIM**

The ornamental design for an inlet baffle for a food waste disposal unit, as shown and described.

**DESCRIPTION**

FIG. 1 is a perspective view showing my new design of an inlet baffle for a food waste disposal unit;

FIG. 2 is a perspective view from below thereof;

FIG. 3 is a top plan view thereof;

FIG. 4 is a bottom plan view thereof; and,

FIG. 5 is a side view thereof, all side views correspond.

The phantom lines indicate environment and do not form a part of the claimed design.

**1 Claim, 3 Drawing Sheets**

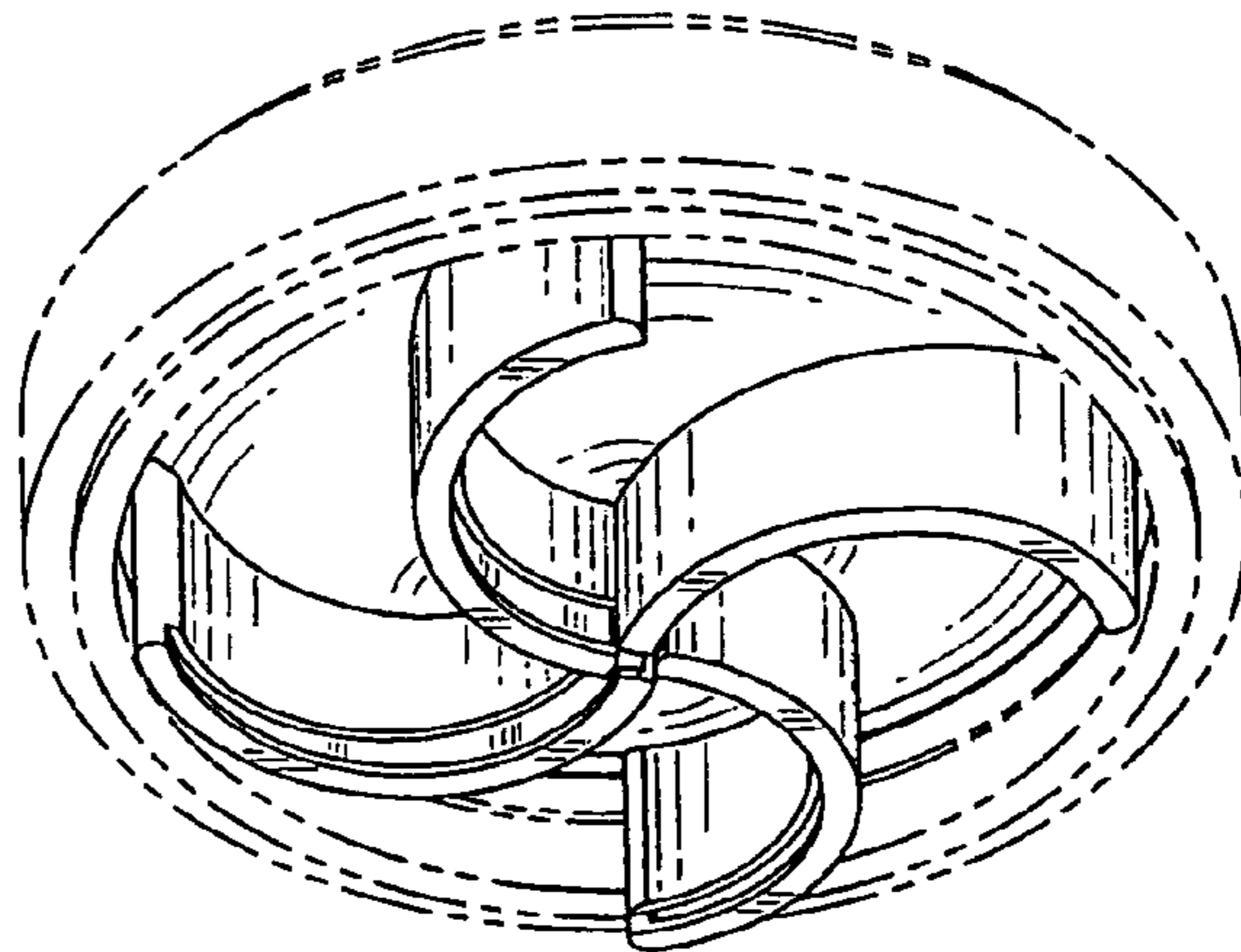
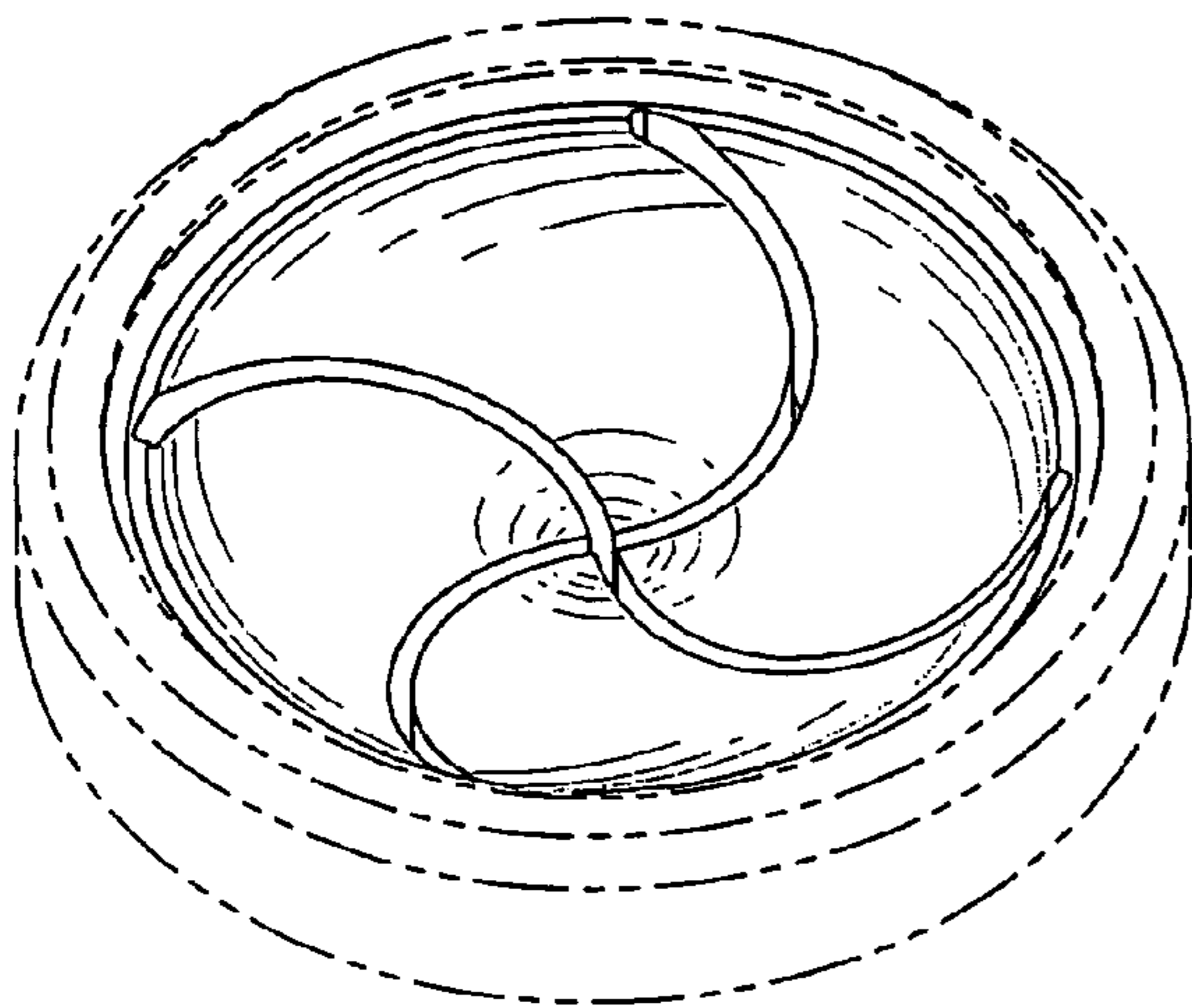

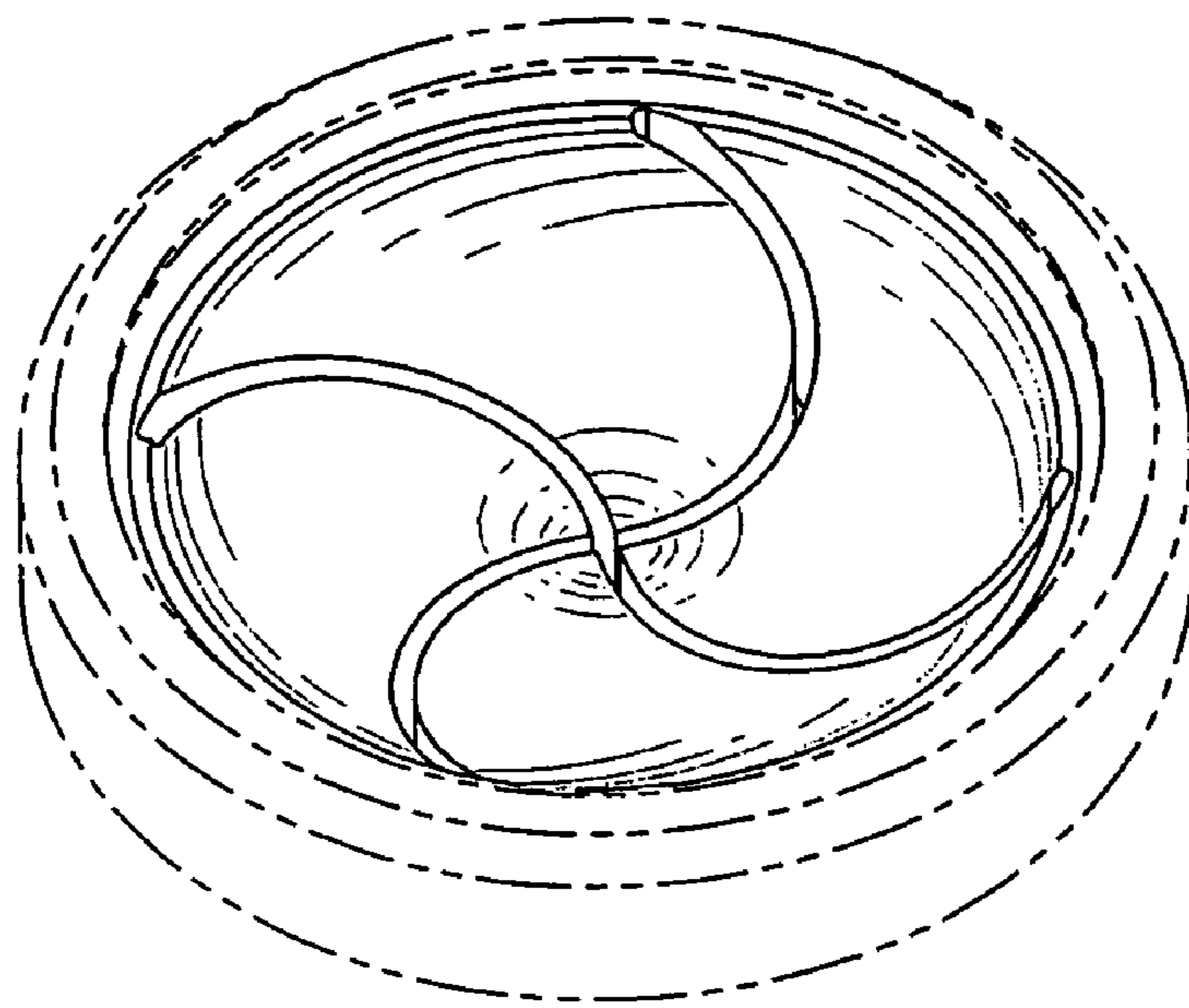

FIG. 1

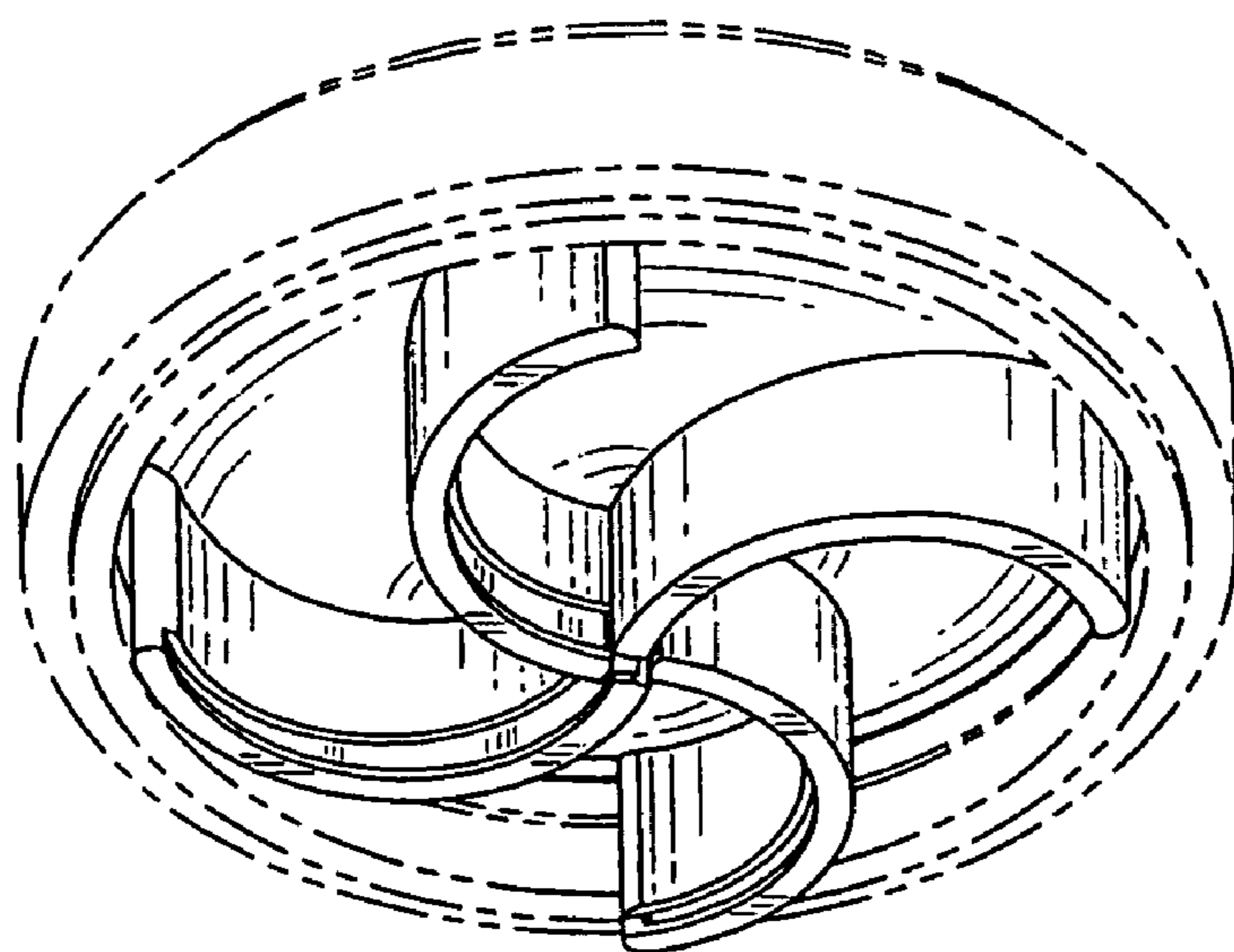

FIG. 2

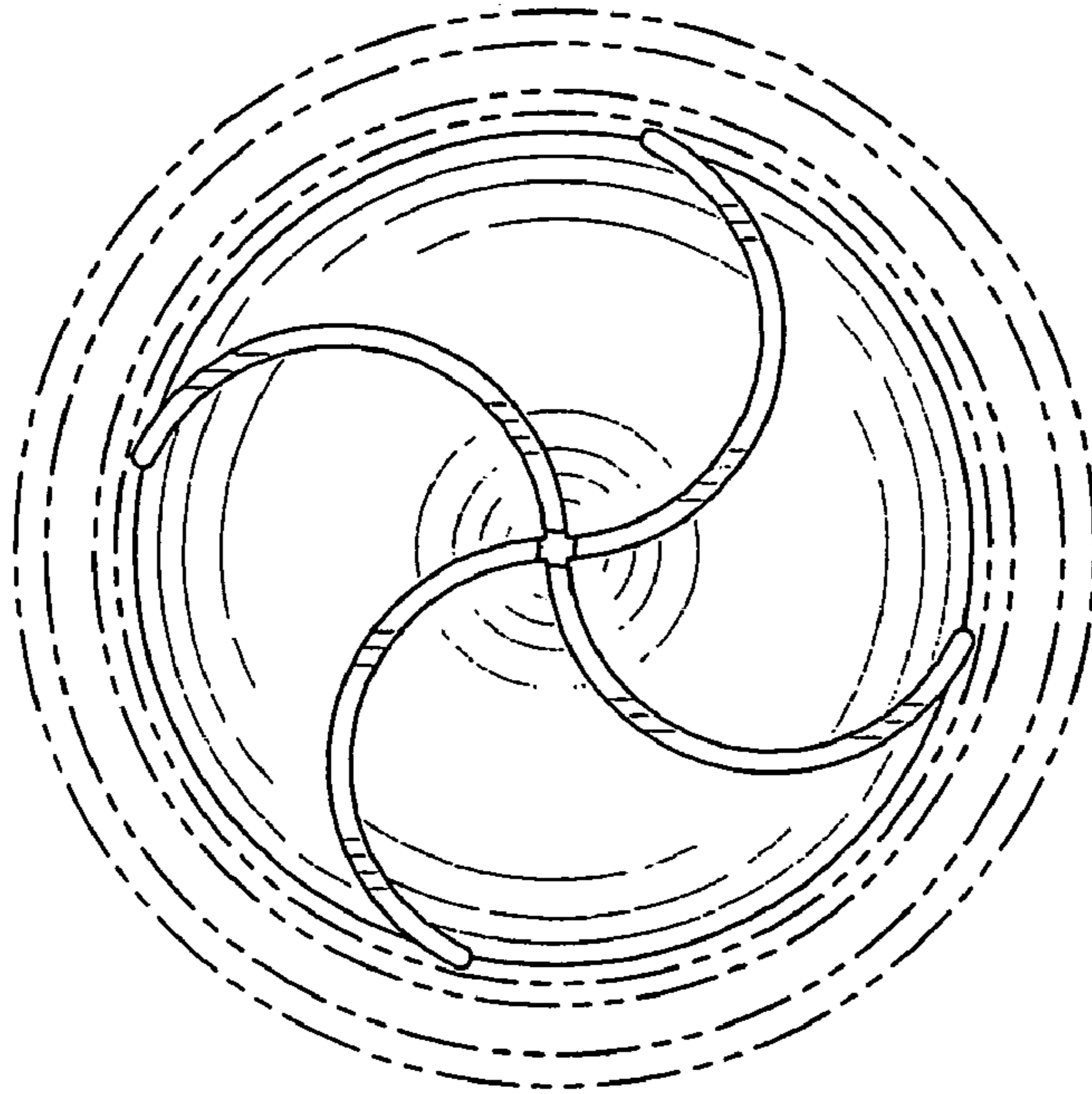

FIG. 3

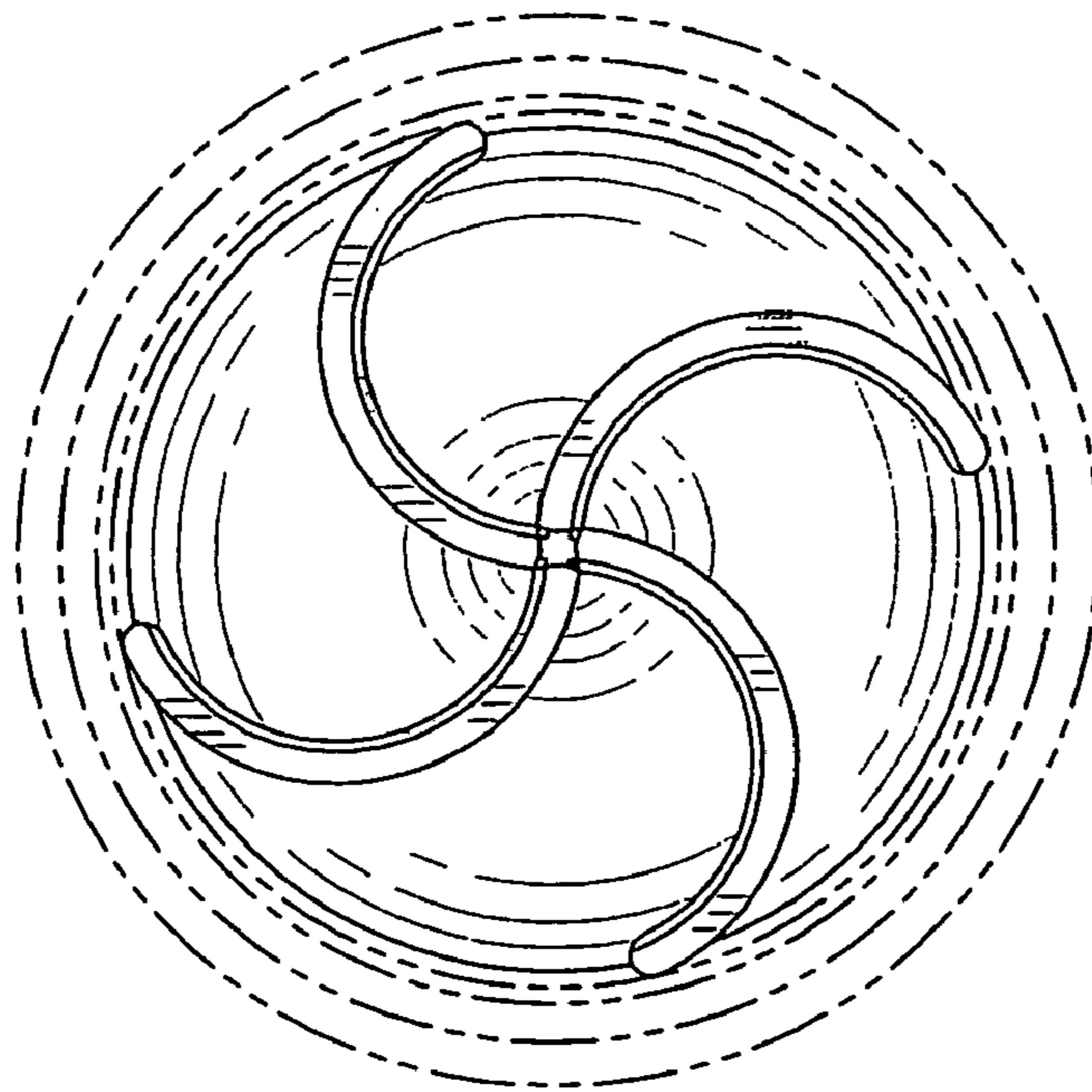

FIG. 4

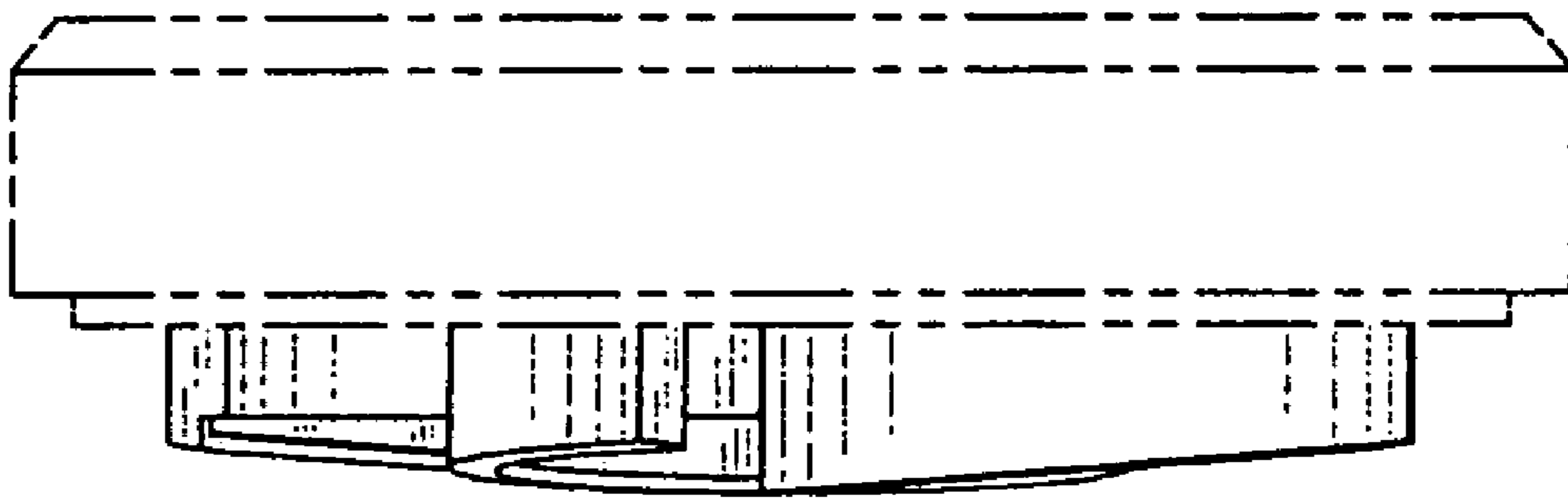

FIG. 5