



US00D581568S

(12) **United States Design Patent**
Bertken

(10) **Patent No.:** **US D581,568 S**

(45) **Date of Patent:** **** Nov. 25, 2008**

(54) **MULTI-PURPOSE SAFETY DEVICE**

(75) Inventor: **Dennis Bertken**, Encinitas, CA (US)

(73) Assignee: **Pacific Pathway, Inc.**, Solana Beach, CA (US)

(**) Term: **14 Years**

(21) Appl. No.: **29/297,179**

(22) Filed: **Nov. 6, 2007**

(51) **LOC (8) Cl.** **26-02**

(52) **U.S. Cl.** **D26/40; D26/38**

(58) **Field of Classification Search** D26/24,
D26/37, 40, 93, 104, 106–108, 110–112,
D26/46, 49–50; 362/171–174, 183, 194–195,
362/202–205

See application file for complete search history.

(56) **References Cited**

U.S. PATENT DOCUMENTS

3,496,349	A	2/1970	Townsend	
3,710,092	A	1/1973	Olbermann, Jr.	
D291,012	S *	7/1987	Liljeqvist D26/104
5,412,548	A	5/1995	Yee	
5,573,109	A	11/1996	Isacson	
6,736,523	B2	5/2004	Alvey	
7,070,297	B1	7/2006	Muhl nickel, Jr.	
D529,212	S	9/2006	Yuen	
D537,968	S *	3/2007	Shiu D26/40
D541,960	S	5/2007	Rothman	
D544,617	S *	6/2007	Johnson D26/37
D553,272	S *	10/2007	Leung D26/37

OTHER PUBLICATIONS

ICC Innovative Concepts Corporation, Megabrite® Self-Powered LED Lights, self-powered AM/FM radio & super bright LED flashlight, dated Jan. 28, 2008, http://www.durapro.com/megabrite/self_powered/10_180.html.

ICC Innovative Concepts Corporation, Megabrite® Self-Powered LED Lights, self-powered AM/FM/Weatherband, dated Jan. 28, 2008, http://www.durapro.com/megabrite/self_powered/10_183.htm.

ICC Innovative Concepts Corporation, Megabrite® Self-Powered LED Lights, self-powered turbo-power, dated Jan. 28, 2008, http://www.durapro.com/megabrite/self_powered/10_157.html.

* cited by examiner

Primary Examiner—Ian Simmons

Assistant Examiner—Dana L Sipos

(74) *Attorney, Agent, or Firm*—Marger Johnson & McCollom, P.C.

(57) **CLAIM**

The ornamental design for a multi-purpose safety device, as shown and described.

DESCRIPTION

FIG. 1 is a top, front, right side perspective view of a multi-purpose safety device according to the present design;

FIG. 2 is a front elevation view thereof, shown at a reduced scale;

FIG. 3 is a rear elevation view thereof;

FIG. 4 is a right side elevation view thereof;

FIG. 5 is a top plan view thereof;

FIG. 6 is a bottom plan view thereof;

FIG. 7 is a top, rear perspective view thereof, shown at an enlarged scale; and,

FIG. 8 is a top, rear perspective view thereof, with the hand-crank member in an extended position.

The broken lines shown in the drawings represent unclaimed details and form no part of the claimed design.

1 Claim, 5 Drawing Sheets

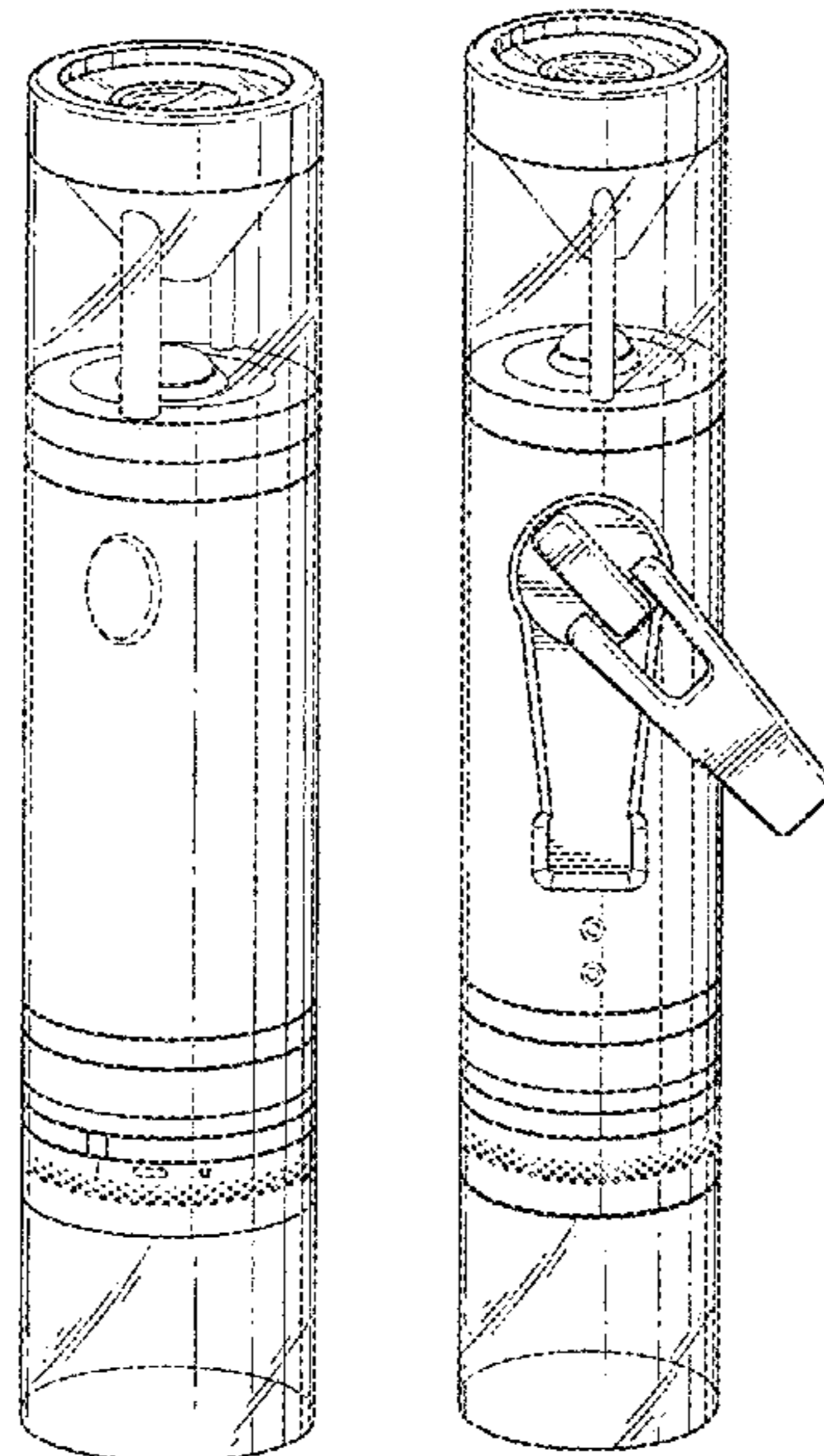

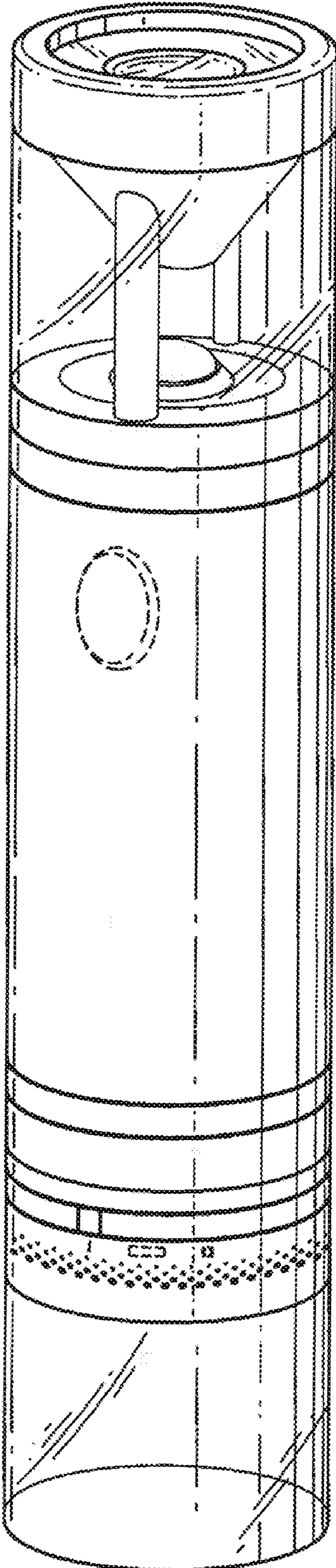

FIG. 1

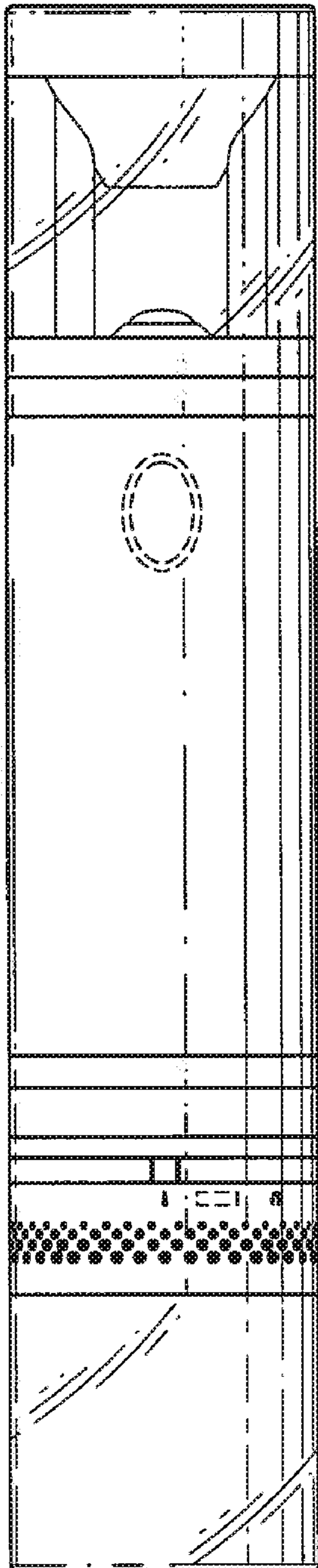

FIG. 2

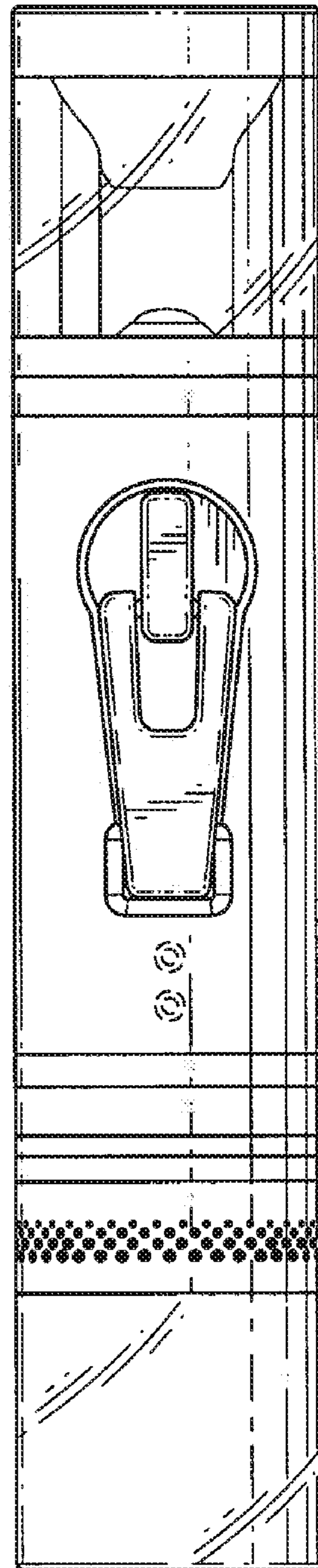

FIG. 3

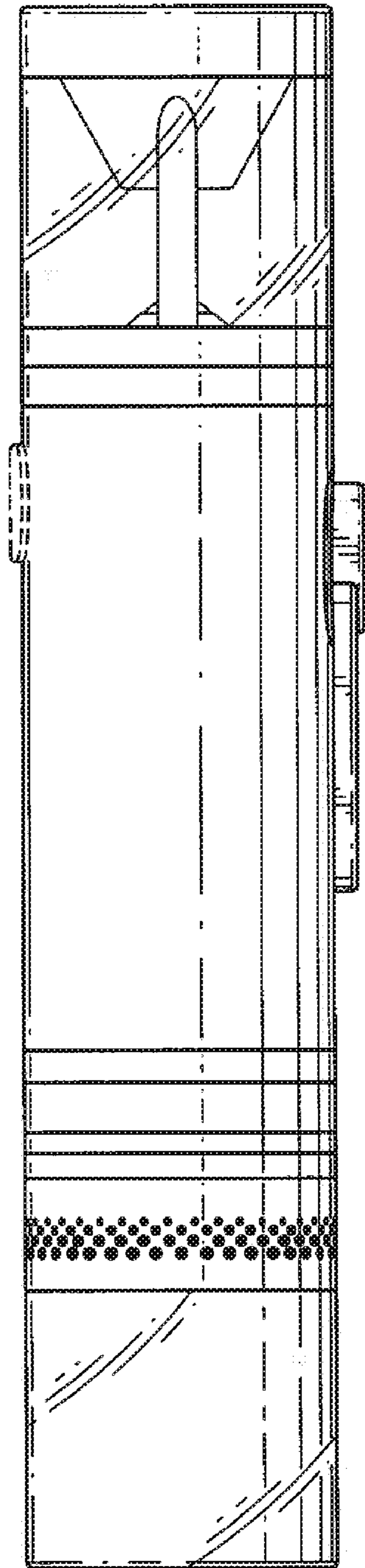

FIG. 4

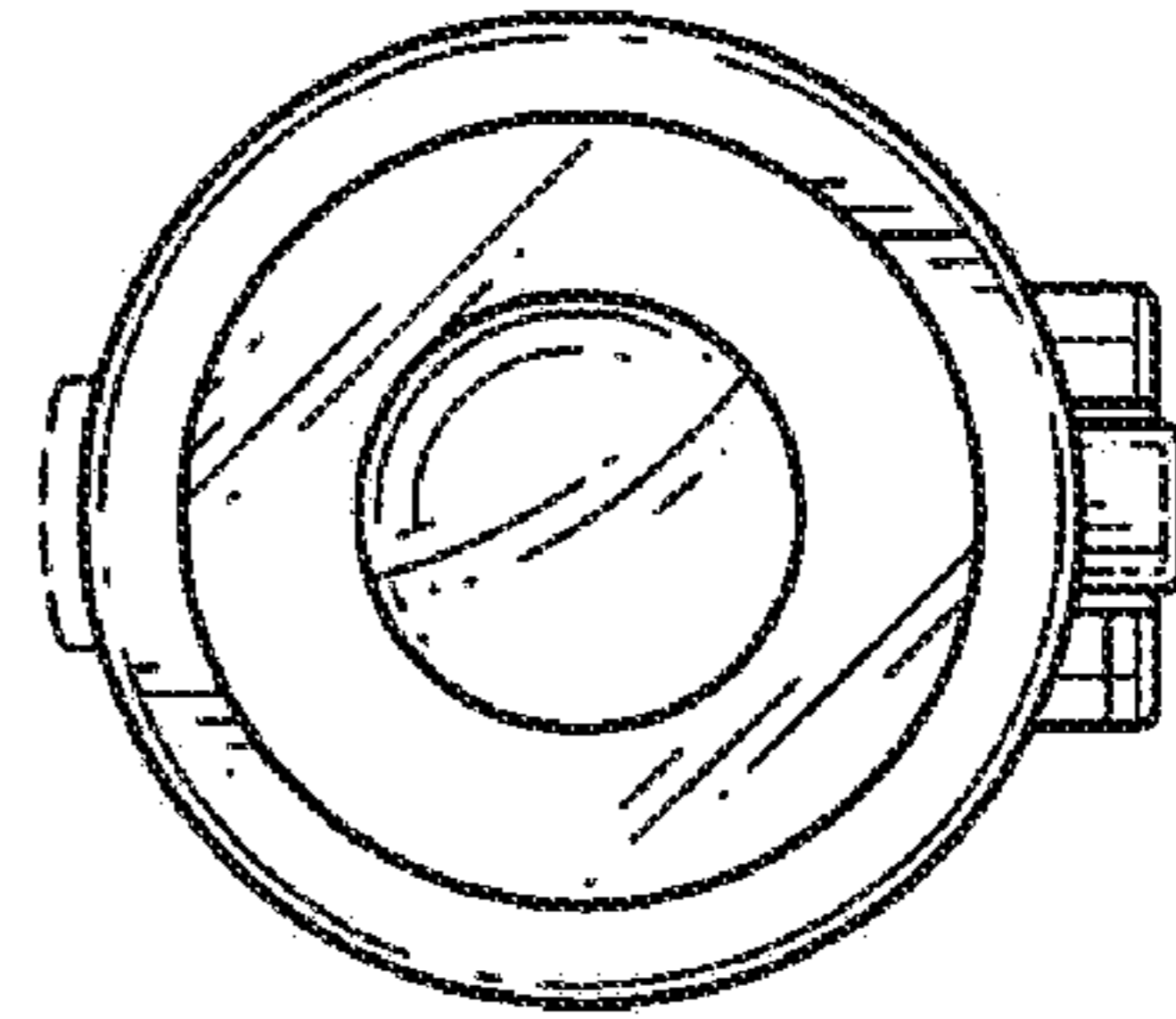

FIG. 5

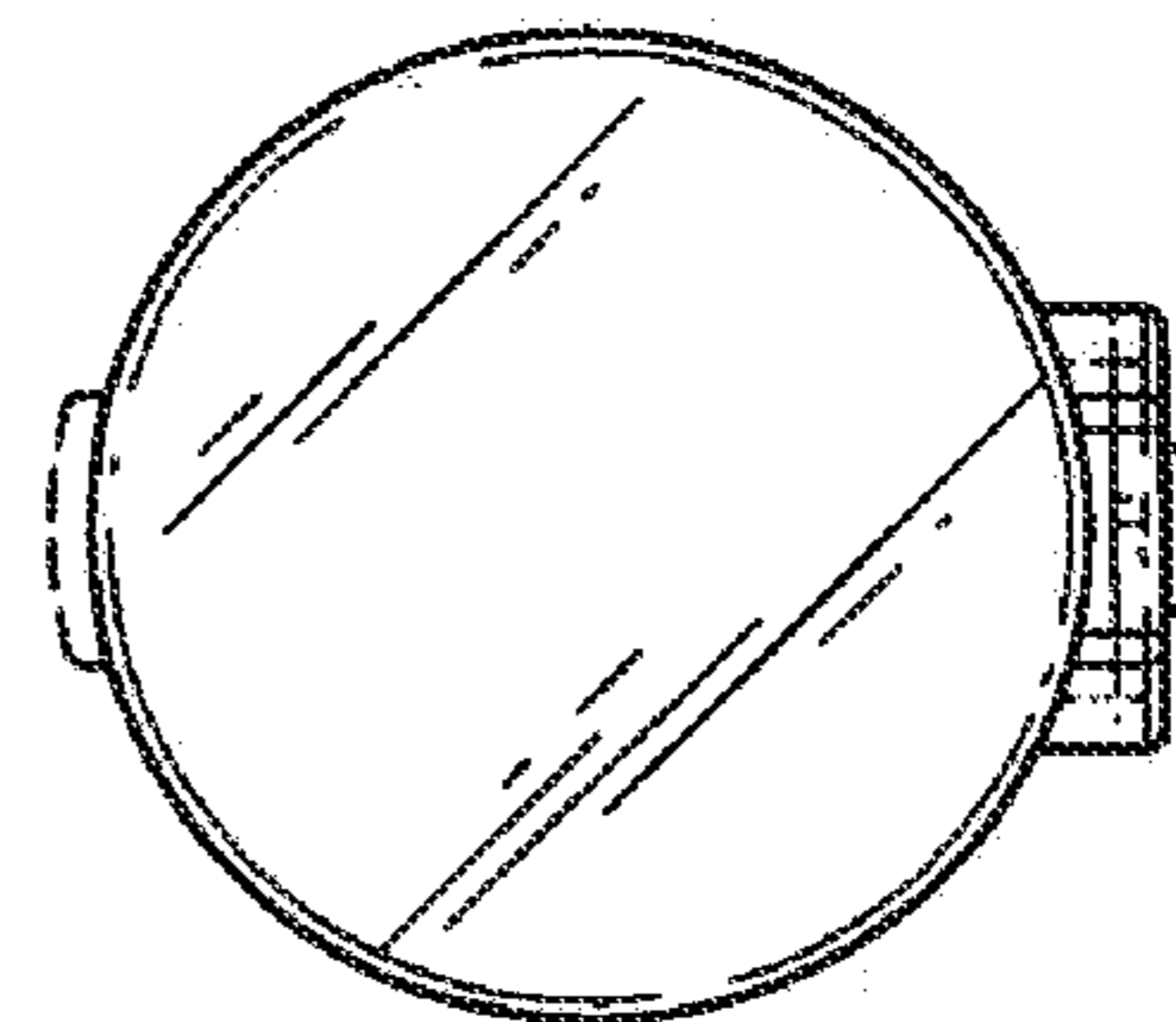

FIG. 6

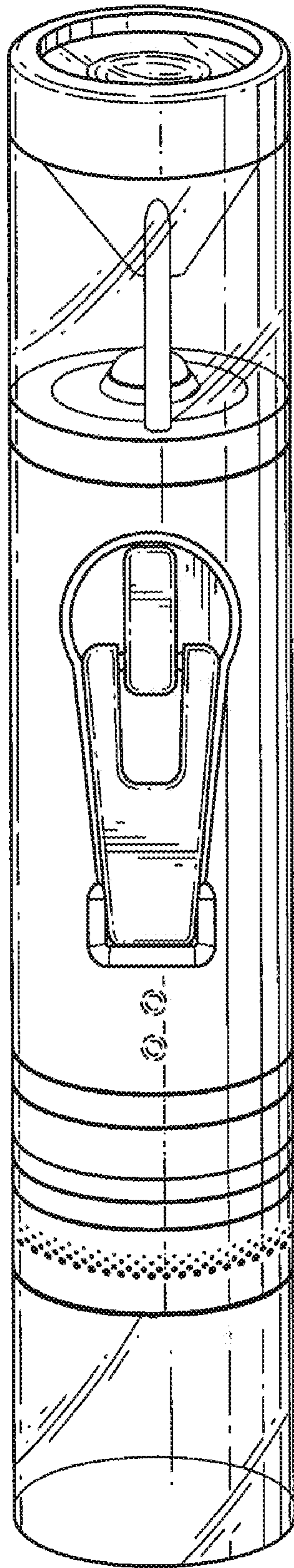

FIG. 7

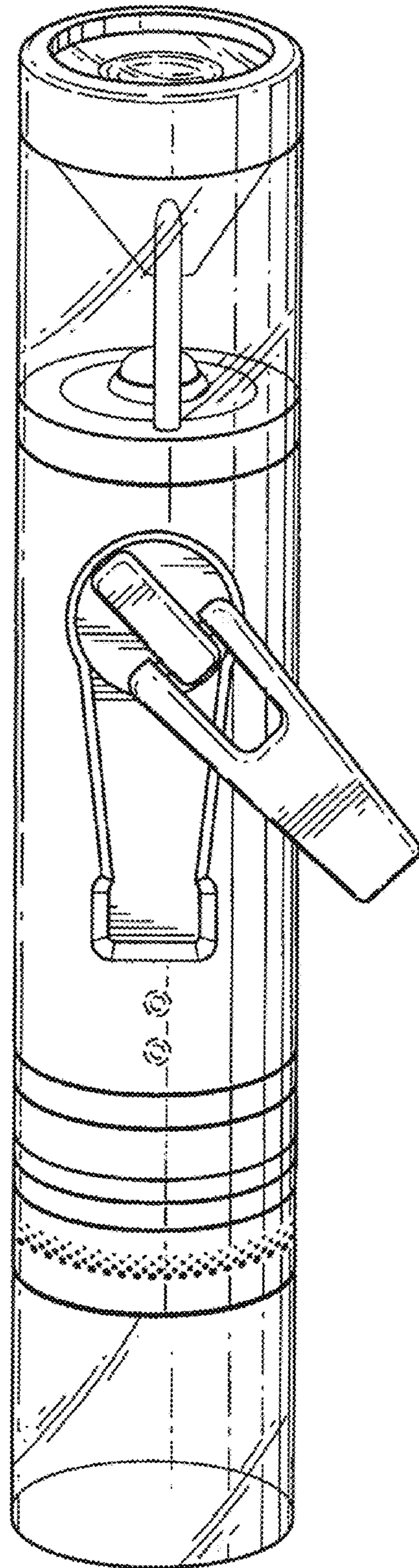

FIG. 8