



US00D581475S

(12) **United States Design Patent**  
**Dickie et al.**

(10) **Patent No.:** **US D581,475 S**  
(45) **Date of Patent:** **\*\* Nov. 25, 2008**

(54) **SHAFT FOR LACROSSE STICK**

(75) Inventors: **Robert G. Dickie**, Newmarket (CA);  
**Steve A. Copeland**, Barrie (CA)

(73) Assignee: **Henson Company, Inc.**, Sinking Spring,  
PA (US)

(\*\*) Term: **14 Years**

(21) Appl. No.: **29/289,771**

(22) Filed: **Jul. 31, 2007**

(51) **LOC (8) Cl.** ..... **21-02**

(52) **U.S. Cl.** ..... **D21/757; D21/724**

(58) **Field of Classification Search** ..... D21/724,  
D21/756-757; 473/505-515

See application file for complete search history.

(56) **References Cited**

**U.S. PATENT DOCUMENTS**

4,206,918	A	6/1980	Lewis, Jr.	
4,739,994	A *	4/1988	Lewis, Jr.	473/513
5,749,798	A *	5/1998	Kuebler et al.	473/549
6,752,730	B1 *	6/2004	Brine et al.	473/513
6,960,144	B2 *	11/2005	Tucker, Sr.	473/513
D534,227	S *	12/2006	Lee	D21/724
7,201,678	B2 *	4/2007	Filice et al.	473/513

D544,932 S \* 6/2007 Scott ..... D21/724  
D558,289 S \* 12/2007 Main ..... D21/757  
2005/0130773 A1 6/2005 Hayden et al.

\* cited by examiner

*Primary Examiner*—Mitchell I Siegel

(74) *Attorney, Agent, or Firm*—Sand & Sebolt

(57) **CLAIM**

The ornamental design for the shaft for lacrosse stick, as shown and described.

**DESCRIPTION**

FIG. 1 is a perspective view of a lacrosse stick shaft in accordance with the present invention shown attached to a head and handle that are illustrated in phantom as they do not form part of the design;

FIG. 2 is a perspective view of a portion of the lacrosse stick shaft of FIG. 1;

FIG. 3 is a cross-sectional view of the shaft taken thru line 3—3 of FIG. 1;

FIG. 4 is a top view of the shaft taken thru line 4—4 of FIG. 3; and,

FIG. 5 is a side view of the shaft taken thru line 5—5 of FIG. 3.

**1 Claim, 5 Drawing Sheets**

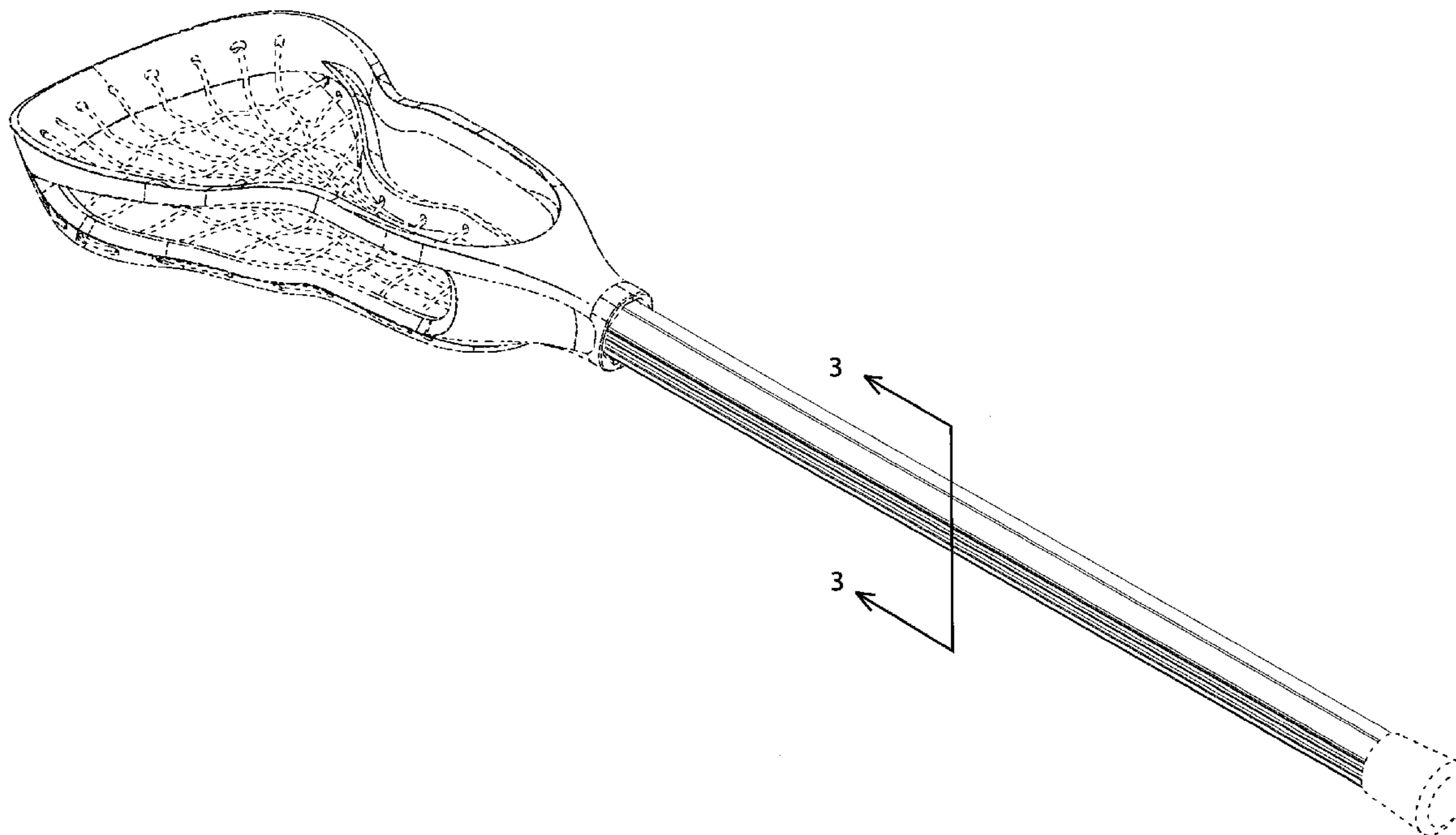

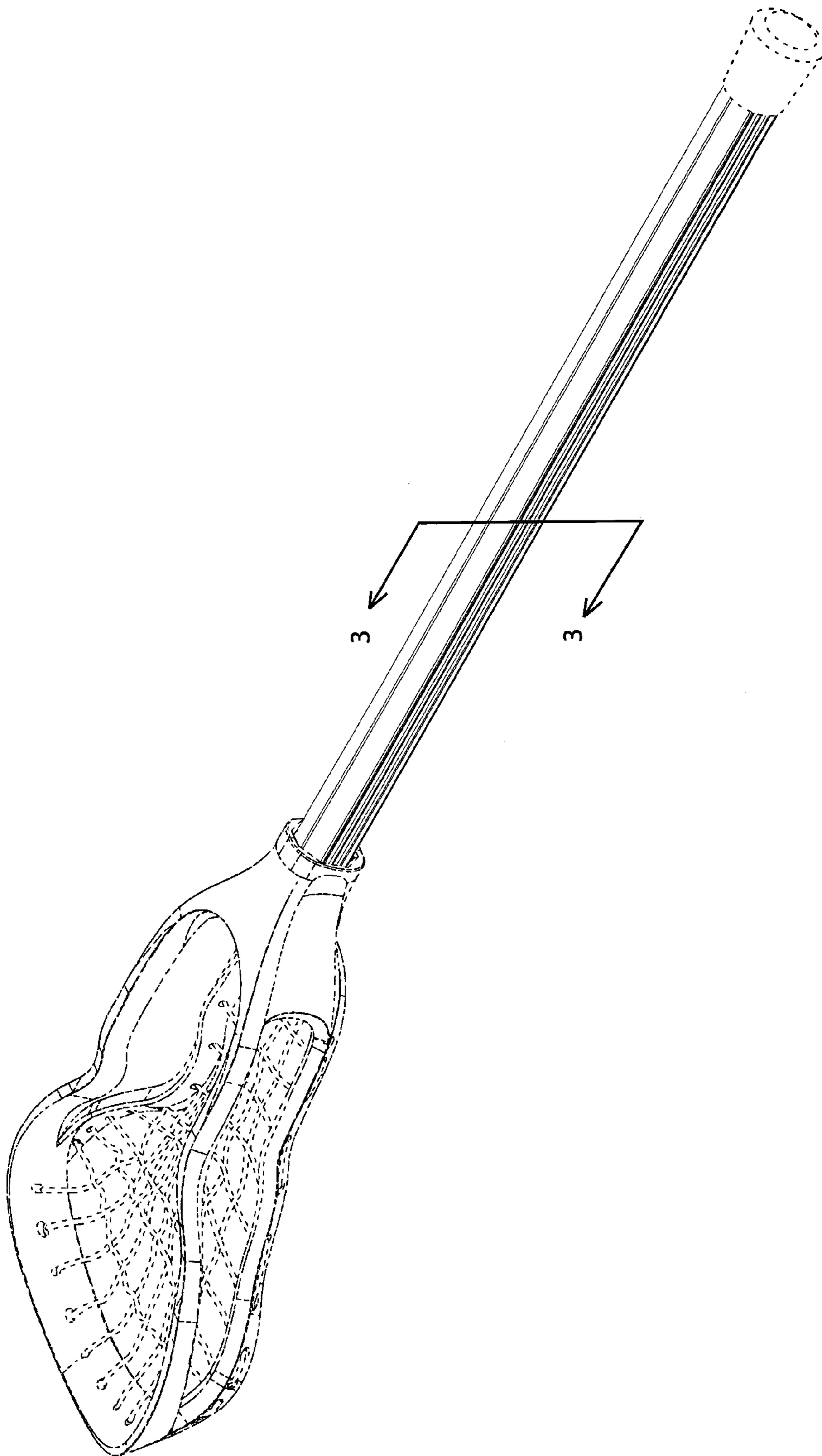

FIG. 1

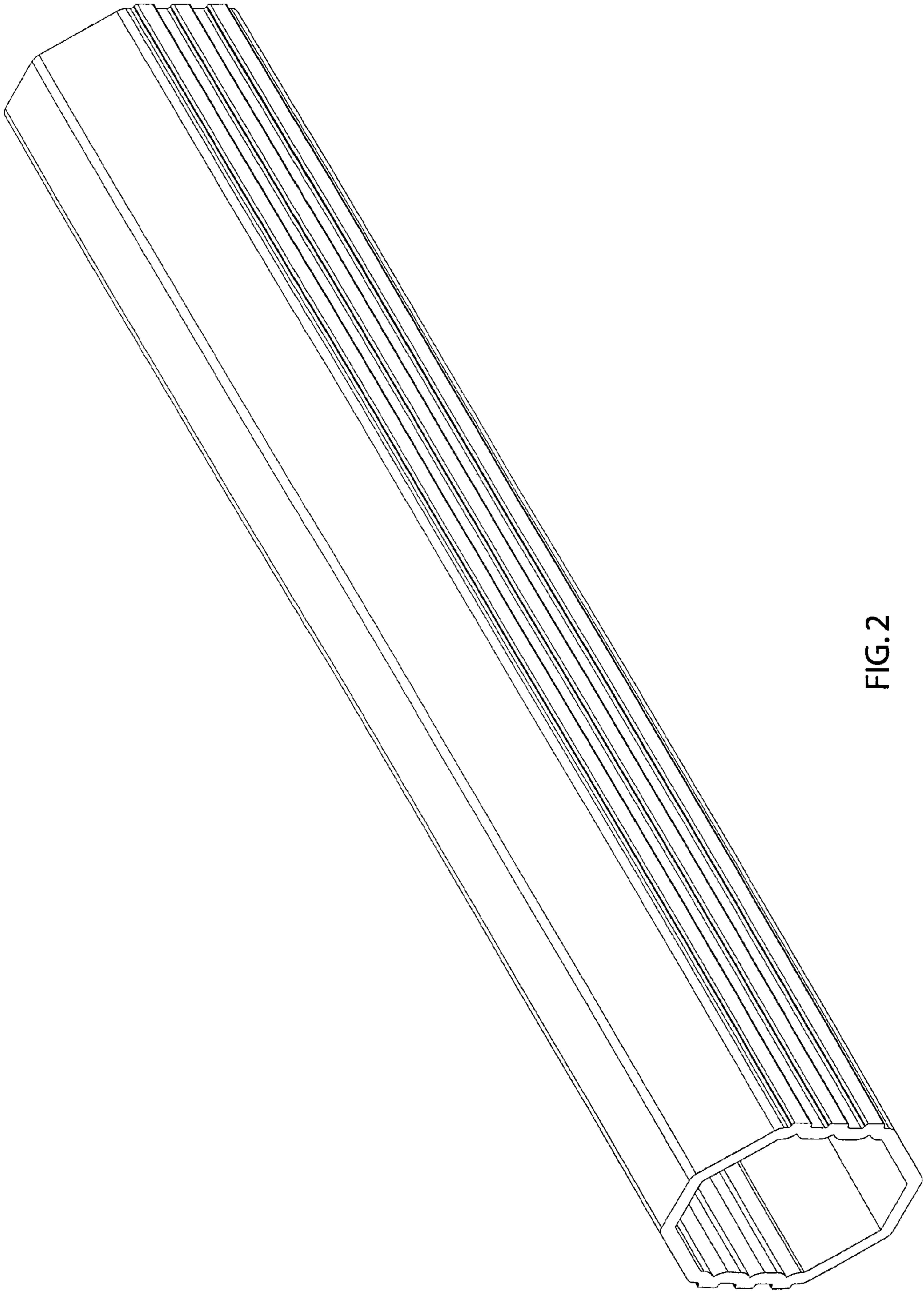

FIG. 2

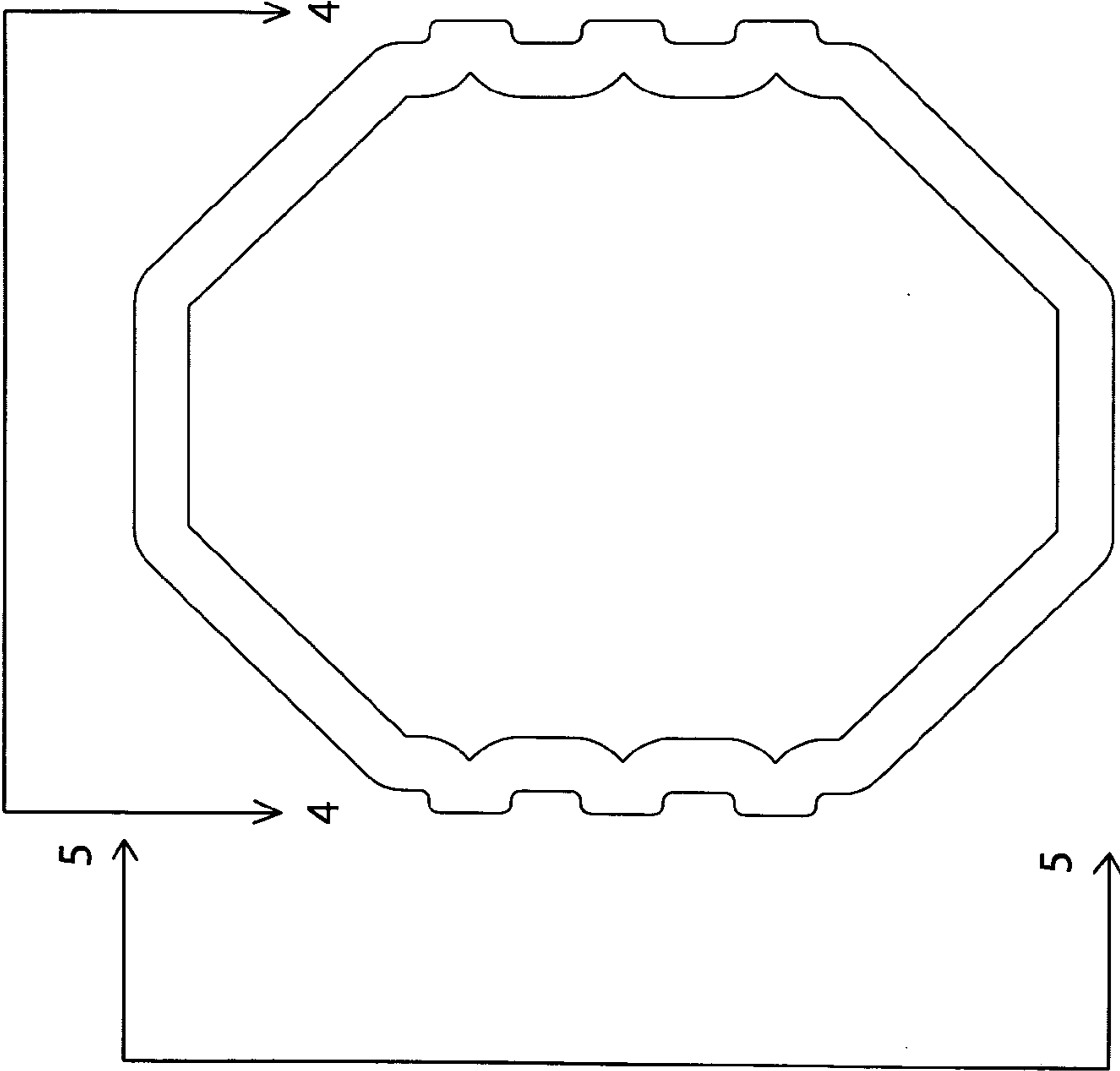

FIG. 3

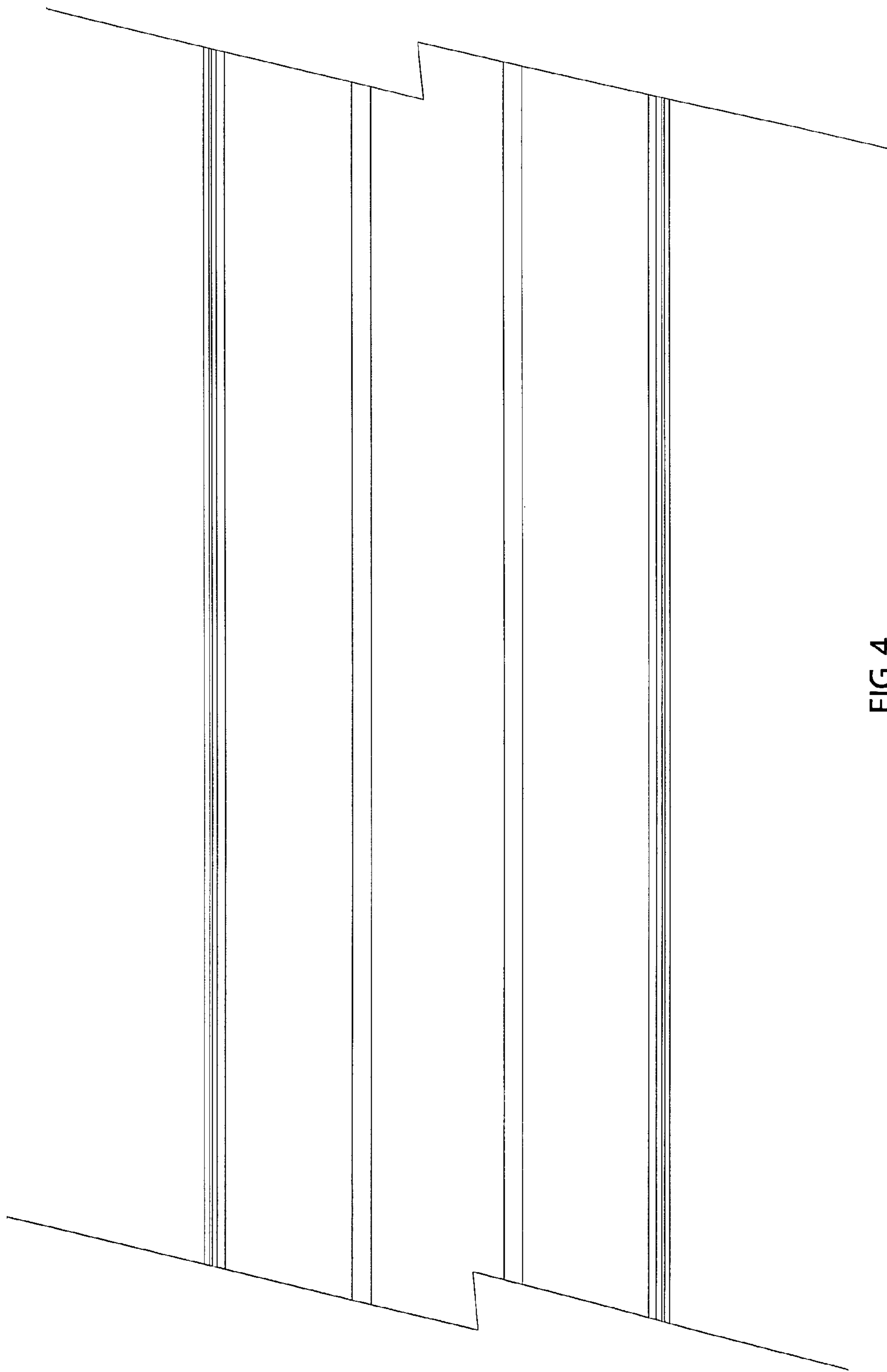

FIG. 4

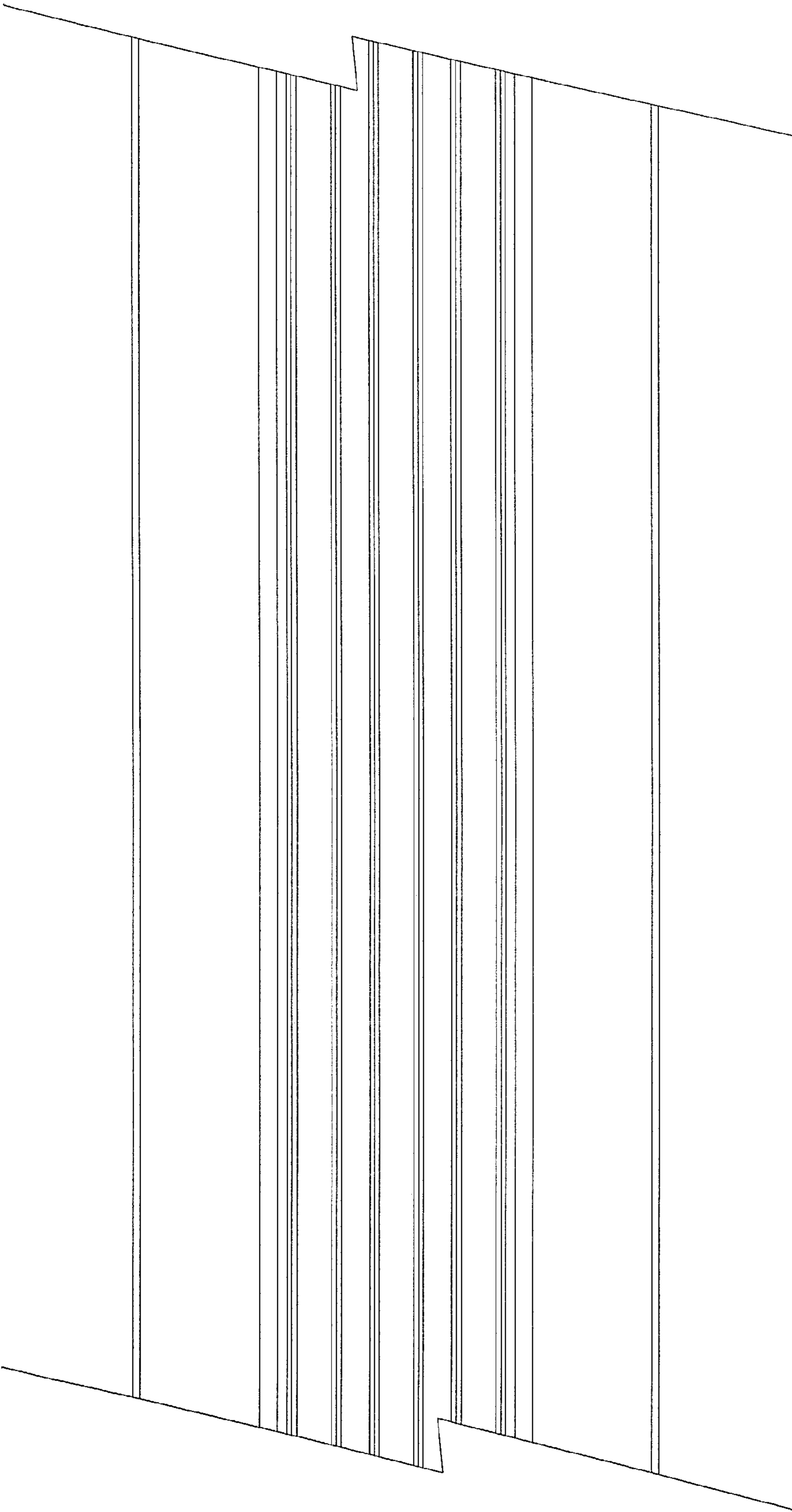

FIG. 5