



US00D581343S

(12) **United States Design Patent**
Cazals

(10) **Patent No.:** **US D581,343 S**
(45) **Date of Patent:** **** Nov. 25, 2008**

(54) **ELEMENT OF AN AIRCRAFT BODY**

(75) Inventor: **Olivier Cazals**, Daux (FR)

(73) Assignee: **Airbus France SAS**, Toulouse (FR)

(**) Term: **14 Years**

(21) Appl. No.: **29/306,062**

(22) Filed: **Apr. 1, 2008**

(51) **LOC (8) Cl.** **12-07**

(52) **U.S. Cl.** **D12/345**; D12/319

(58) **Field of Classification Search** D12/319,
D12/345, 400, 190, 494, 322, 331, 337, 196;
244/117 R, 119, 125-126; D32/18, 24, 32
See application file for complete search history.

(56) **References Cited**

U.S. PATENT DOCUMENTS

D150,692 S *	8/1948	Glasgow	D12/339
D217,888 S *	6/1970	Biamond	D12/324
D354,474 S *	1/1995	Murphy et al.	D12/340
D354,936 S *	1/1995	Kraft et al.	D12/344
D359,472 S *	6/1995	Day	D12/343
D370,456 S *	6/1996	Buchsel et al.	D12/340
5,699,662 A *	12/1997	Born et al.	60/39.5
D517,467 S *	3/2006	Vigneron et al.	D12/319

OTHER PUBLICATIONS

U.S. Appl. No. 29/305,899; Title: Elements of an Aircraft Tail, filed Mar. 29, 2008.

U.S. Appl. No. 29/306,053; Title: Elements of an Aircraft Tail, filed Apr. 1, 2008.

U.S. Appl. No. 29/306,060; Title: Element of an Aircraft, filed Apr. 1, 2008.

U.S. Appl. No. 29/306,066; Title: Elements of an Aircraft Tail, filed Apr. 1, 2008.

U.S. Appl. No. 29/306,067; Title: Elements of an Aircraft Tail, filed Apr. 1, 2008.

U.S. Appl. No. 29/306,068; Title: Elements of an Aircraft Tail, filed Apr. 1, 2008.

U.S. Appl. No. 29/306,078; Title: Elements of an Aircraft Tail, filed Apr. 1, 2008.

U.S. Appl. No. 29/306,079; Title: Elements of an Aircraft Tail, filed Apr. 1, 2008.

U.S. Appl. No. 29/306,412; Title: Elements of an Aircraft Tail, filed Apr. 9, 2008.

U.S. Appl. No. 29/306,405; Title: Elements of an Aircraft Tail, filed Apr. 9, 2008.

U.S. Appl. No. 29/306,406; Title: Elements of an Aircraft Tail, filed Apr. 9, 2008.

U.S. Appl. No. 29/306,407; Title: Elements of an Aircraft Tail, filed Apr. 9, 2008.

U.S. Appl. No. 29/306,408; Title: Elements of an Aircraft Tail, filed Apr. 9, 2008.

U.S. Appl. No. 29/306,409; Title: Elements of an Aircraft Tail, filed Apr. 9, 2008.

U.S. Appl. No. 29/306,410; Title: Elements of an Aircraft Tail, filed Apr. 9, 2008.

* cited by examiner

Primary Examiner—Charles A. Rademaker

Assistant Examiner—Dana L Sipos

(74) *Attorney, Agent, or Firm*—Osler, Hoskin & Harcourt LLP

(57) **CLAIM**

The ornamental design of an element of an aircraft body, as shown and described.

DESCRIPTION

FIG. 1 is a top, front, right side perspective view of an element of an aircraft body showing my new design;

FIG. 2 is a bottom, rear, right side perspective view thereof;

FIG. 3 is a right side elevation view thereof;

FIG. 4 is a top plan view thereof;

FIG. 5 is a bottom plan view;

FIG. 6 is a top, front, right side perspective view of the element of an aircraft body shown applied to an aircraft; and,

FIG. 7 is a top, rear, left side perspective partial view thereof shown at an enlarged scale.

Throughout the Figures, broken lines showing environment or structure are for illustrative purposes only and form no part of the claimed design.

1 Claim, 5 Drawing Sheets

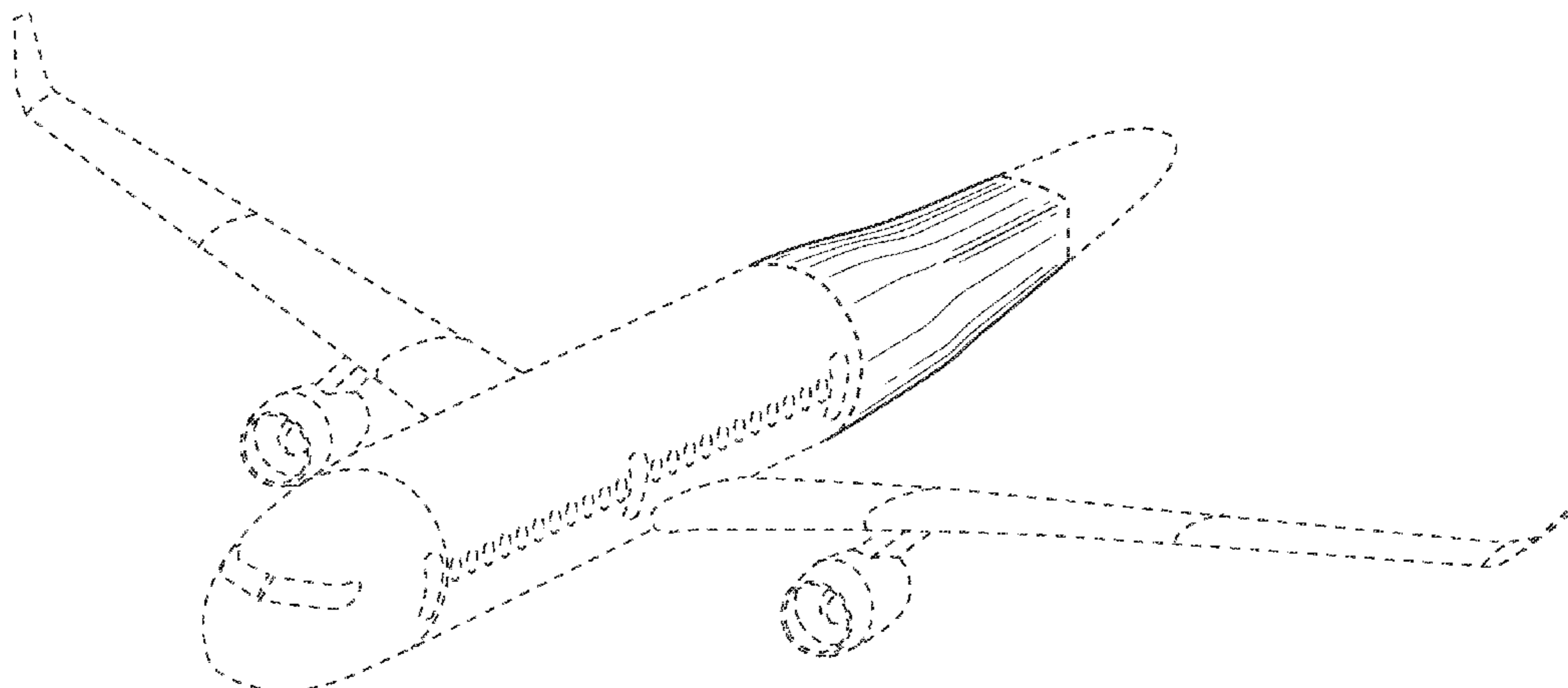

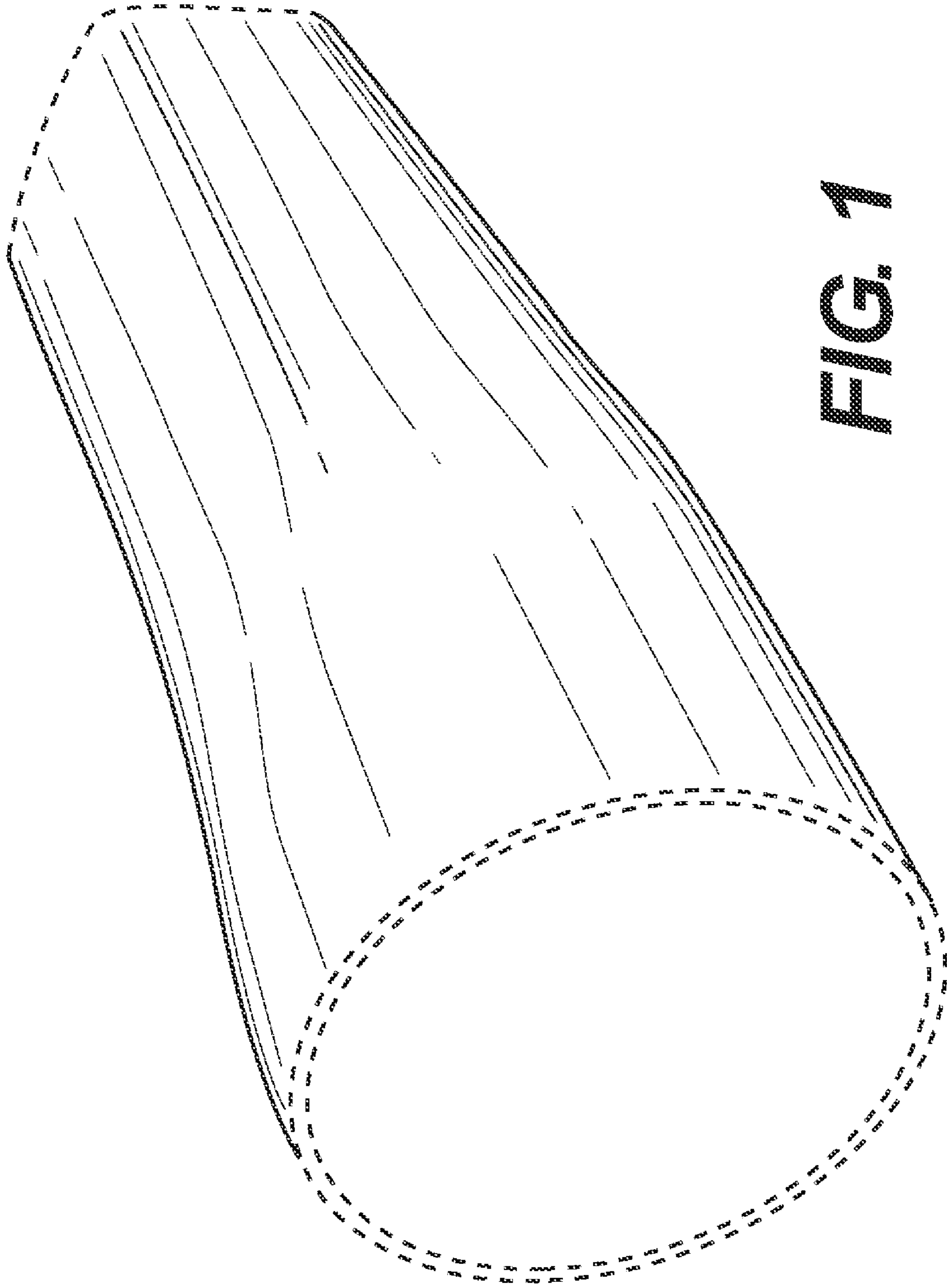

FIG. 1

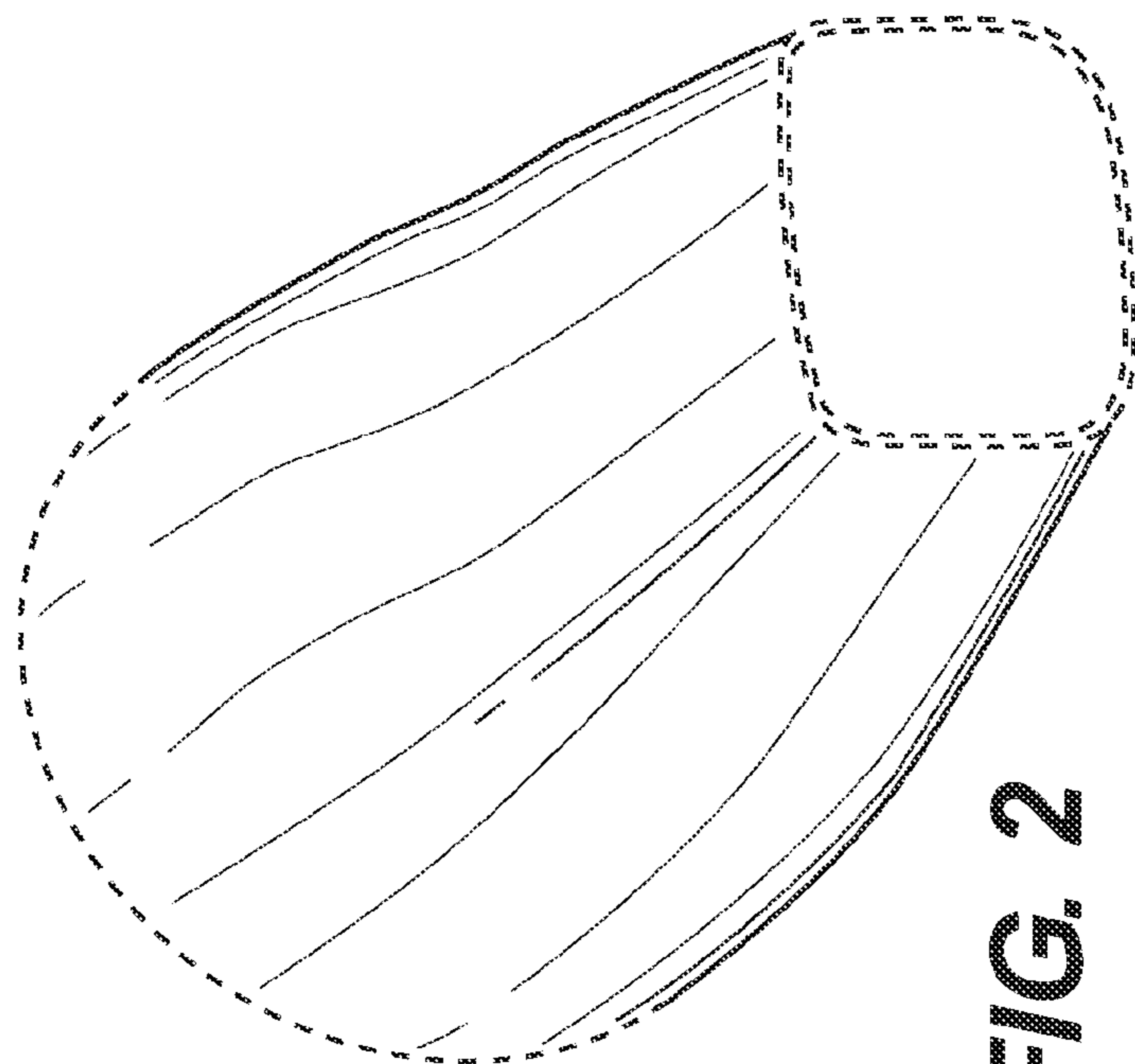

FIG. 2

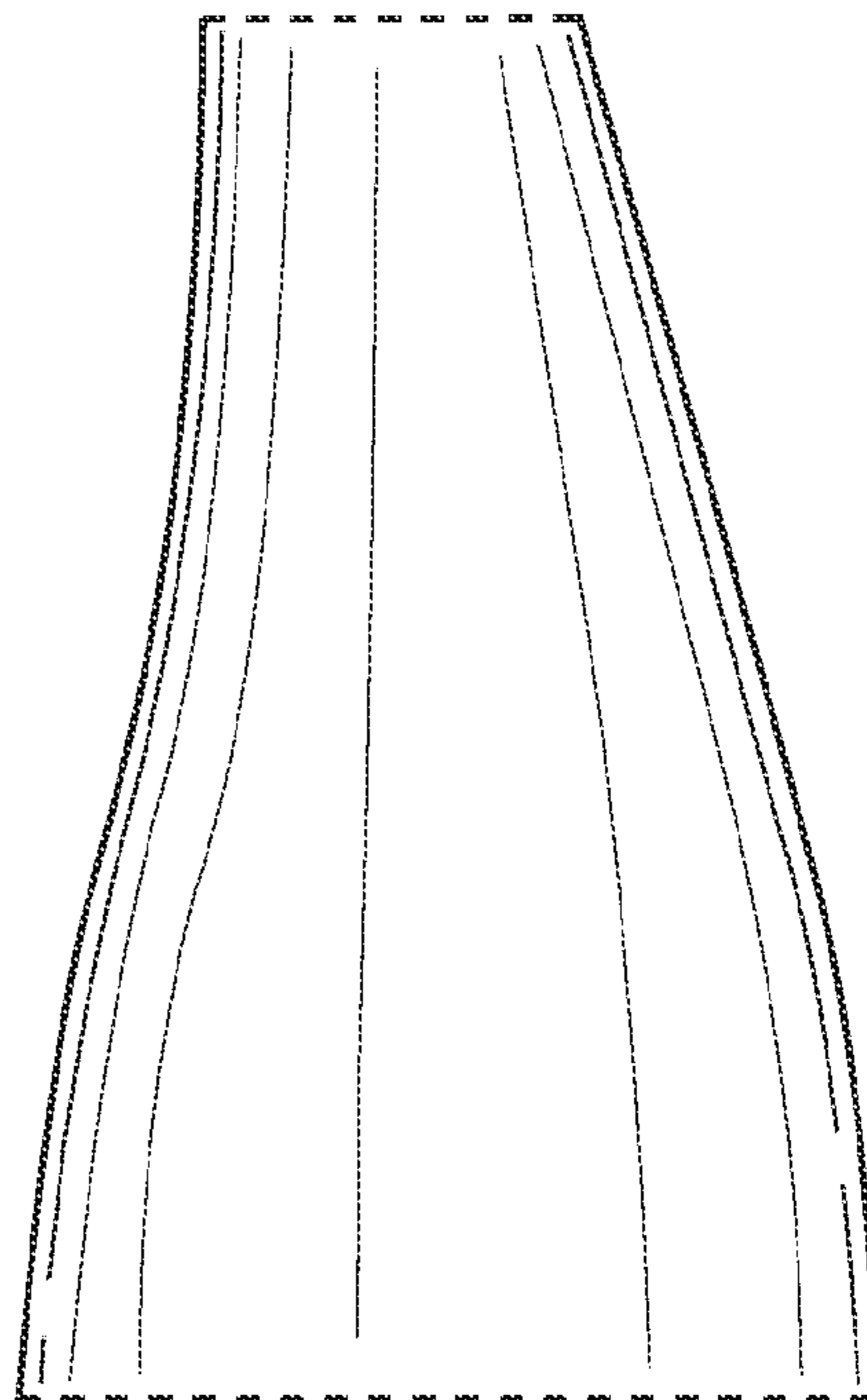

FIG. 3

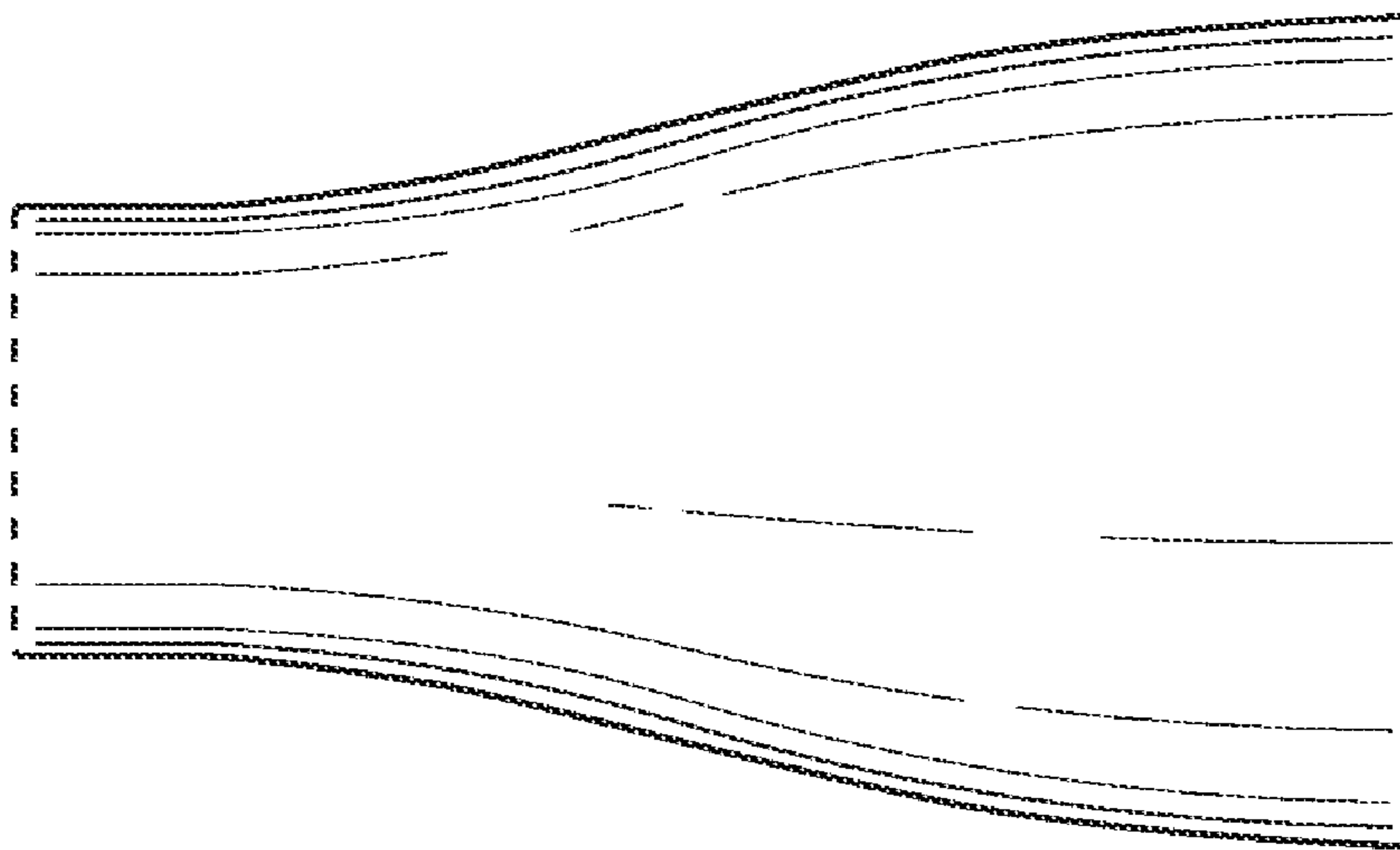

FIG. 4

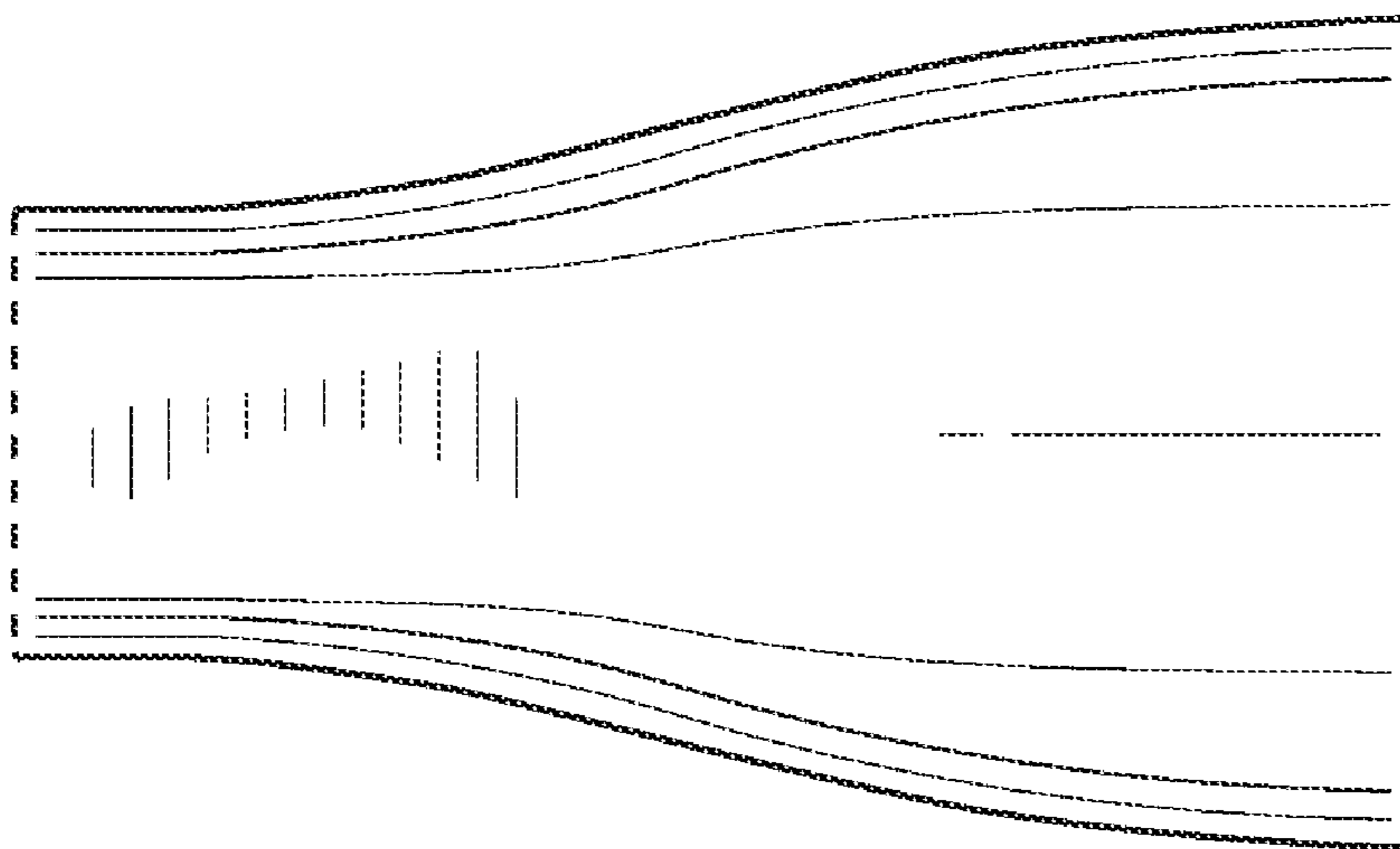

FIG. 5

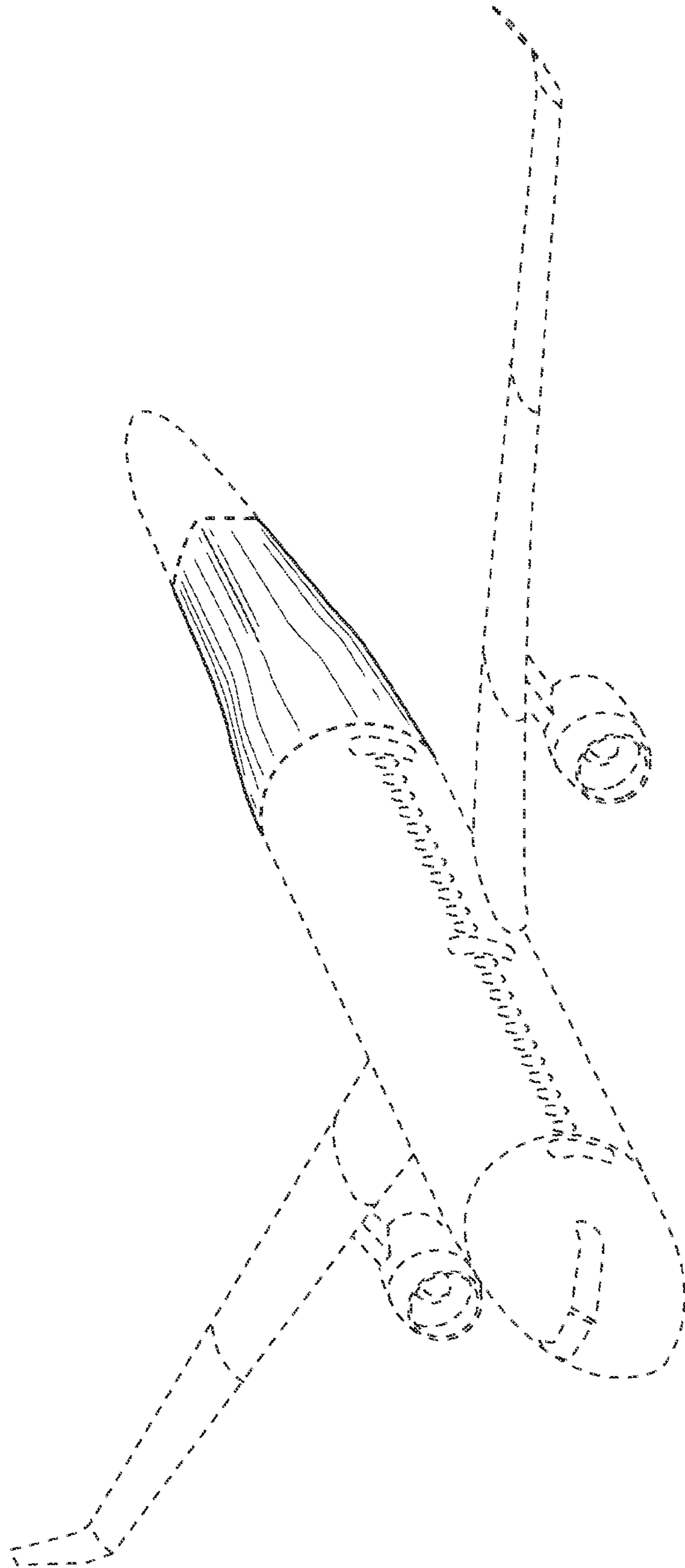

FIG. 6

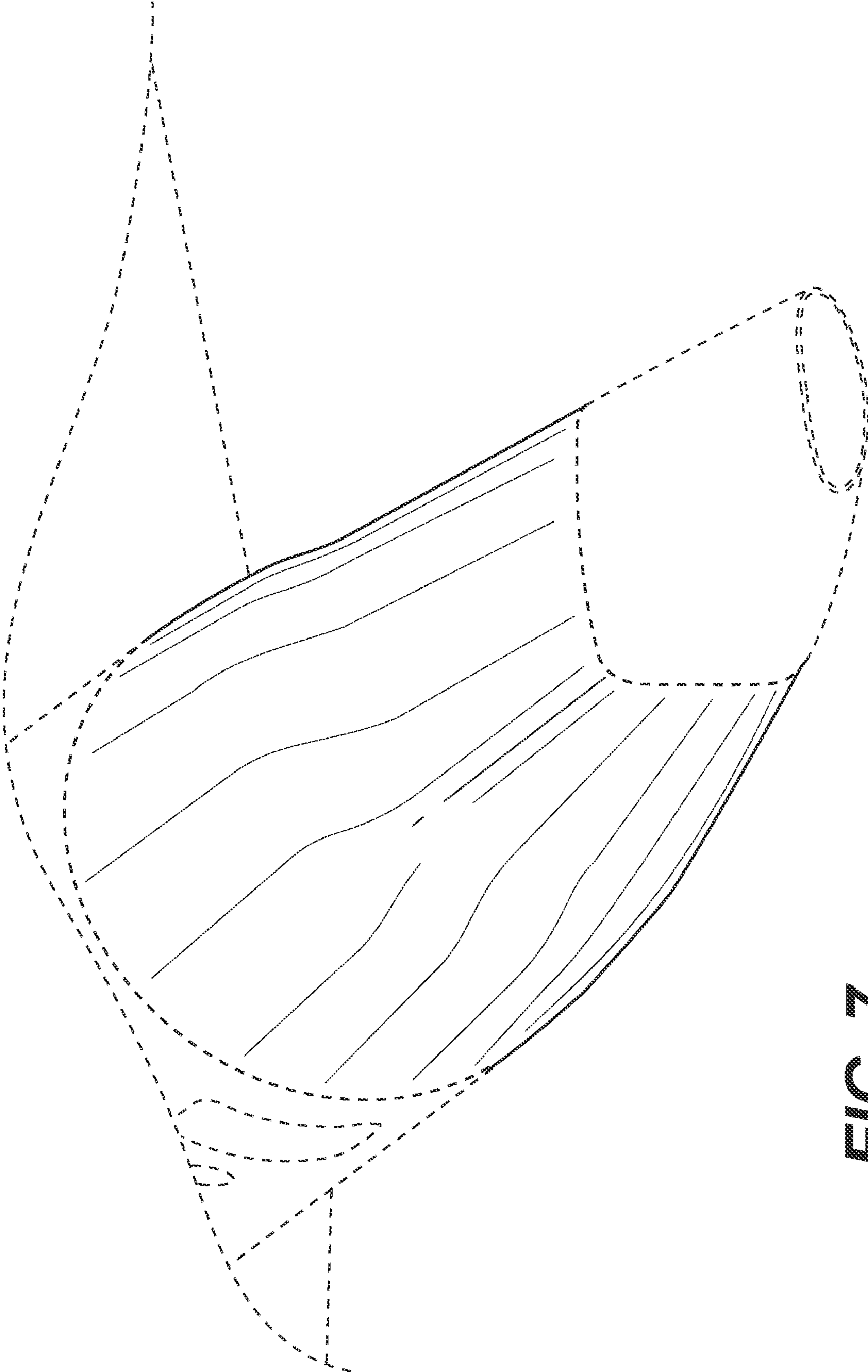

FIG. 7