



US00D581342S

(12) **United States Design Patent**
Cazals

(10) **Patent No.:** **US D581,342 S**
(45) **Date of Patent:** **** Nov. 25, 2008**

(54) **ELEMENT OF AN AIRCRAFT**

(75) Inventor: **Olivier Cazals**, Daux (FR)

(73) Assignee: **Airbus France SAS**, Toulouse (FR)

(**) Term: **14 Years**

(21) Appl. No.: **29/306,060**

(22) Filed: **Apr. 1, 2008**

(51) **LOC (8) Cl.** **12-07**

(52) **U.S. Cl.** **D12/345; D12/319**

(58) **Field of Classification Search** D12/319,
D12/345, 400, 190, 494, 322, 331, 337, 196;
244/117 R, 119, 125–126; D32/18, 24, 32
See application file for complete search history.

(56) **References Cited**

U.S. PATENT DOCUMENTS

- D350,722 S * 9/1994 Figueroa D12/345
- D354,474 S * 1/1995 Murphy et al. D12/340
- D355,058 S * 1/1995 Phelan D32/18
- D359,472 S * 6/1995 Day D12/343
- 5,699,662 A * 12/1997 Born et al. 60/39.5
- D432,743 S * 10/2000 Santiago D32/18
- D435,707 S * 12/2000 Leung D32/18
- D517,467 S * 3/2006 Vigneron et al. D12/319
- D533,322 S * 12/2006 Blateri D32/25

OTHER PUBLICATIONS

- U.S. Appl. No. 29/305,899; Title: Elements of an Aircraft Tail, filed Mar. 29, 2008.
- U.S. Appl. No. 29/306,053; Title: Elements of an Aircraft Tail, filed Apr. 1, 2008.
- U.S. Appl. No. 29/306,062; Title: Elements of an Aircraft Body, filed Apr. 1, 2008.
- U.S. Appl. No. 29/306,066; Title: Elements of an Aircraft Tail, filed Apr. 1, 2008.
- U.S. Appl. No. 29/306,067; Title: Elements of an Aircraft Tail, filed Apr. 1, 2008.
- U.S. Appl. No. 29/306,068; Title: Elements of an Aircraft Tail, filed Apr. 1, 2008.
- U.S. Appl. No. 29/306,078; Title: Elements of an Aircraft Tail, filed Apr. 1, 2008.

- U.S. Appl. No. 29/306,079; Title: Elements of an Aircraft Tail, filed Apr. 1, 2008.
- U.S. Appl. No. 29/306,412; Title: Elements of an Aircraft Tail, filed Apr. 9, 2008.
- U.S. Appl. No. 29/306,405; Title: Elements of an Aircraft Tail, filed Apr. 9, 2008.
- U.S. Appl. No. 29/306,406; Title: Elements of an Aircraft Tail, filed Apr. 9, 2008.
- U.S. Appl. No. 29/306,407; Title: Elements of an Aircraft Tail, filed Apr. 9, 2008.
- U.S. Appl. No. 29/306,408; Title: Elements of an Aircraft Tail, filed Apr. 9, 2008.
- U.S. Appl. No. 29/306,409; Title: Elements of an Aircraft Tail, filed Apr. 9, 2008.
- U.S. Appl. No. 29/306,410; Title: Elements of an Aircraft Tail, filed Apr. 9, 2008.

* cited by examiner

Primary Examiner—Charles A. Rademaker

Assistant Examiner—Dana L Sipos

(74) *Attorney, Agent, or Firm*—Osler, Hoskin & Harcourt LLP

(57) **CLAIM**

The ornamental design of an element of an aircraft, as shown and described.

DESCRIPTION

FIG. 1 is a top, front, right side perspective view of an element of an aircraft showing my new design;

FIG. 2 is a bottom, rear, right side perspective view thereof;

FIG. 3 is a right side elevation view thereof;

FIG. 4 is a top plan view thereof;

FIG. 5 is a bottom plan view;

FIG. 6 is a top, front, right side perspective view of the element of an aircraft shown applied to an aircraft; and,

FIG. 7 is a top, rear, left side perspective partial view thereof.

Throughout the Figures, broken lines showing environment or structure are for illustrative purposes only and form no part of the claimed design.

1 Claim, 4 Drawing Sheets

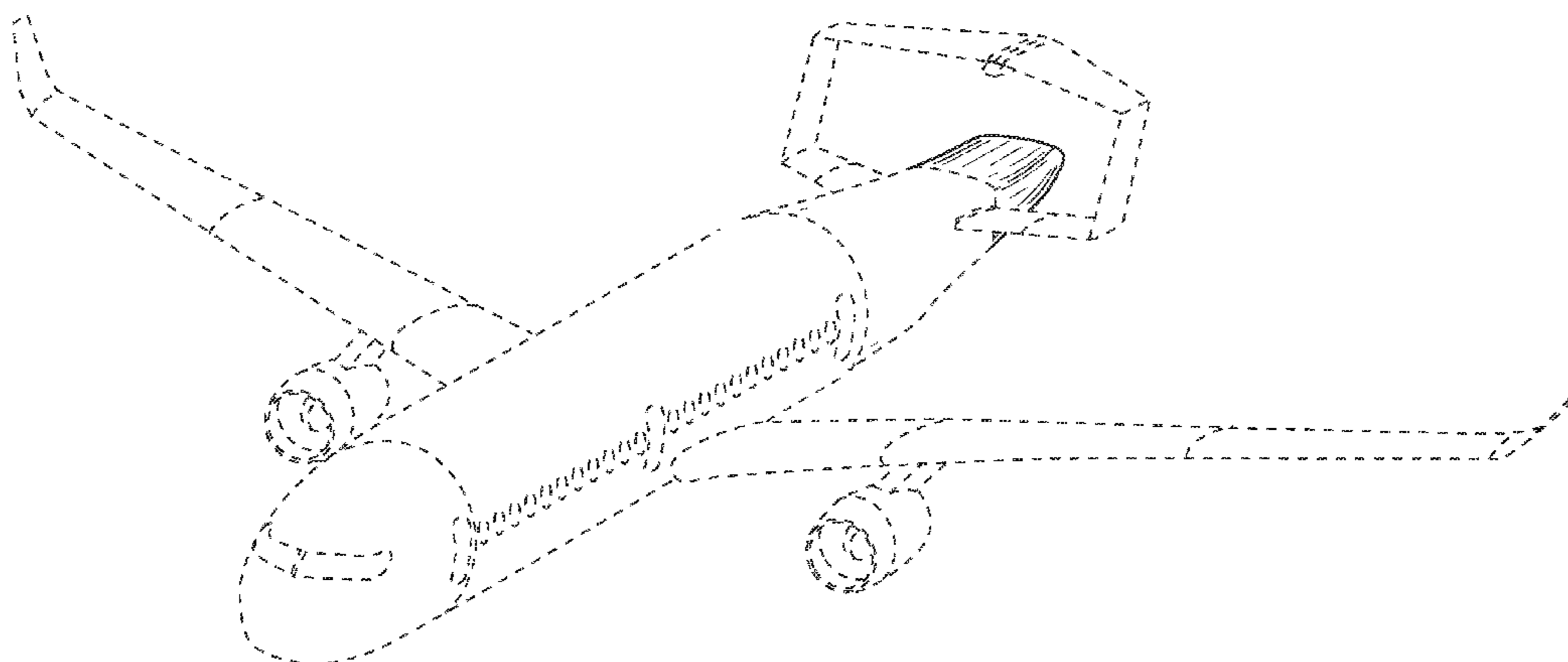

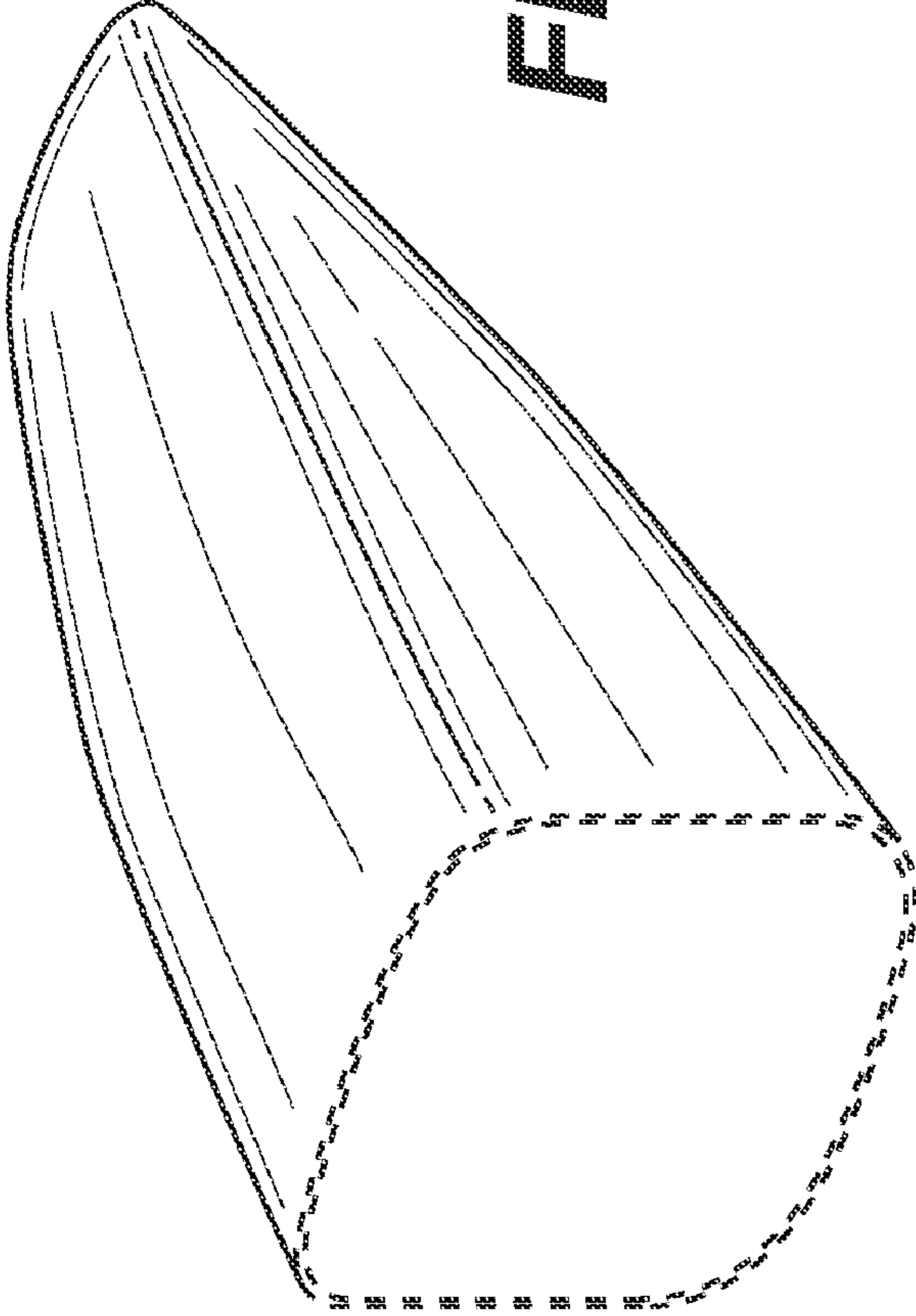

FIG. 1

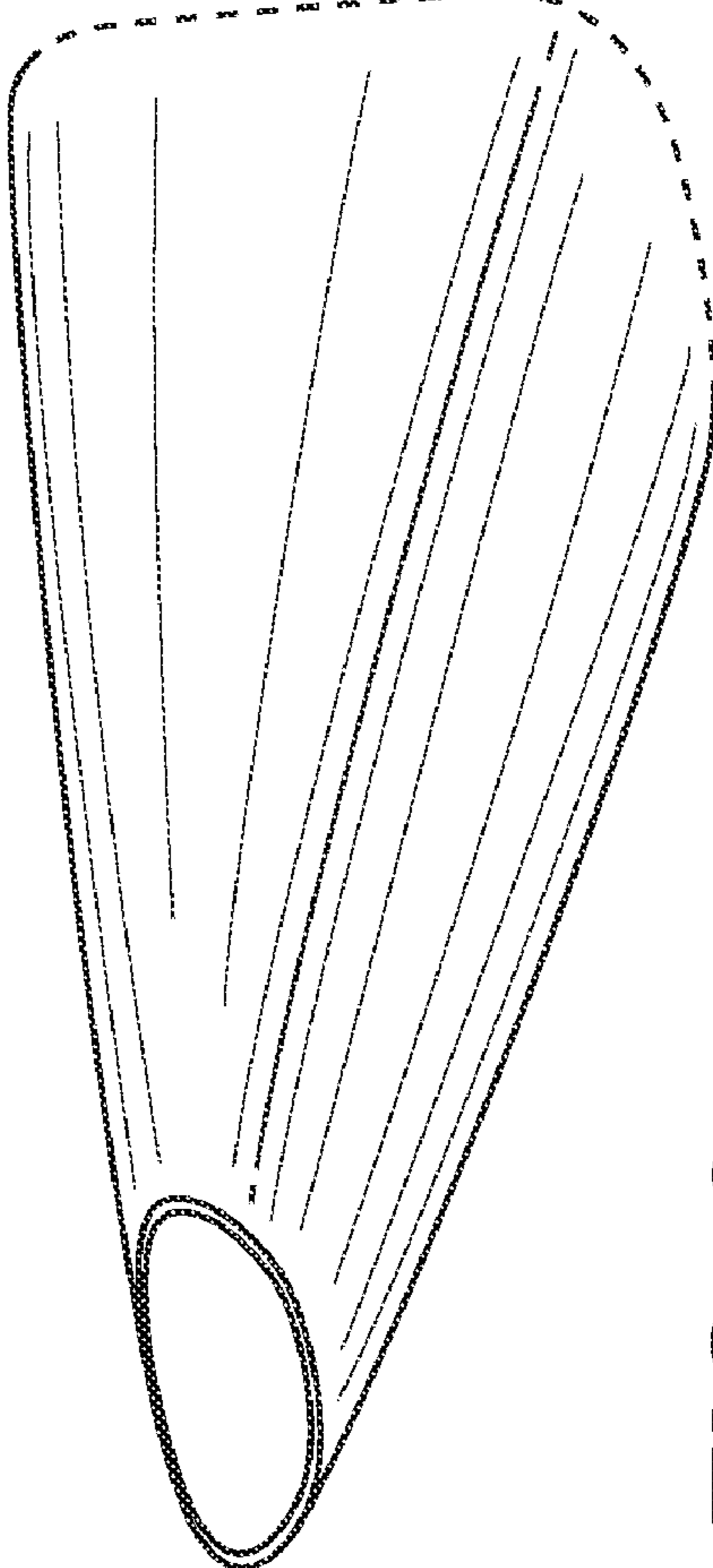

FIG. 2

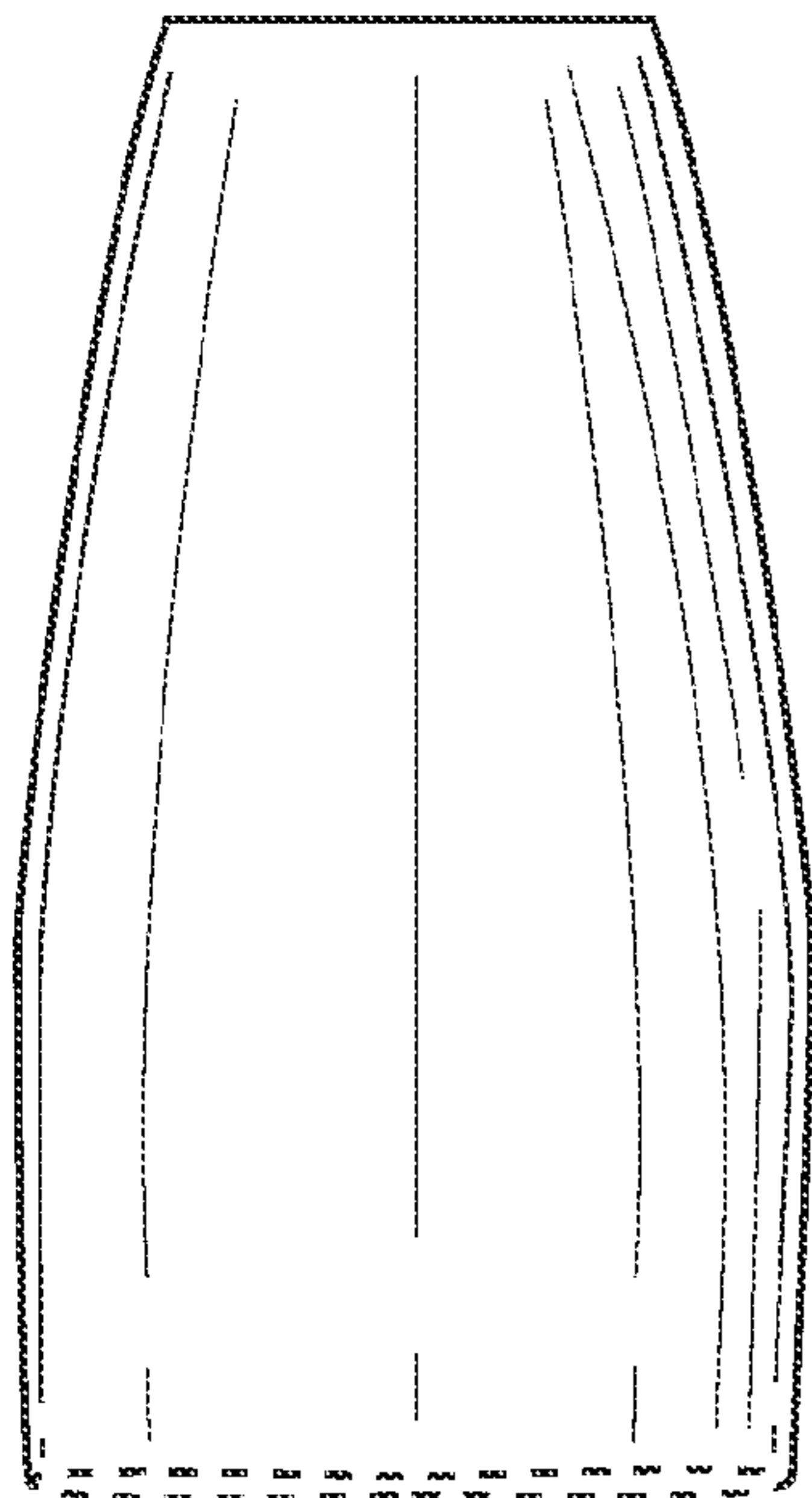

FIG. 3

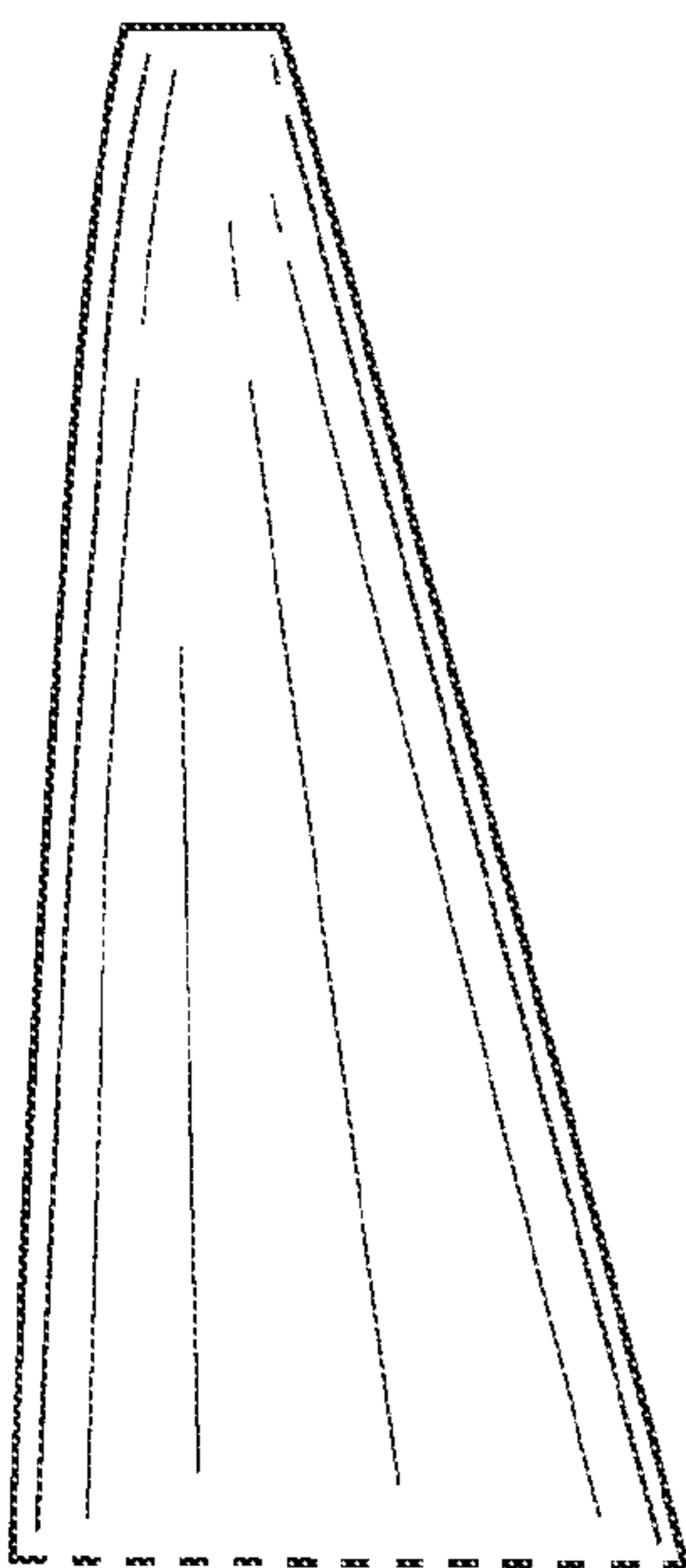

FIG. 4

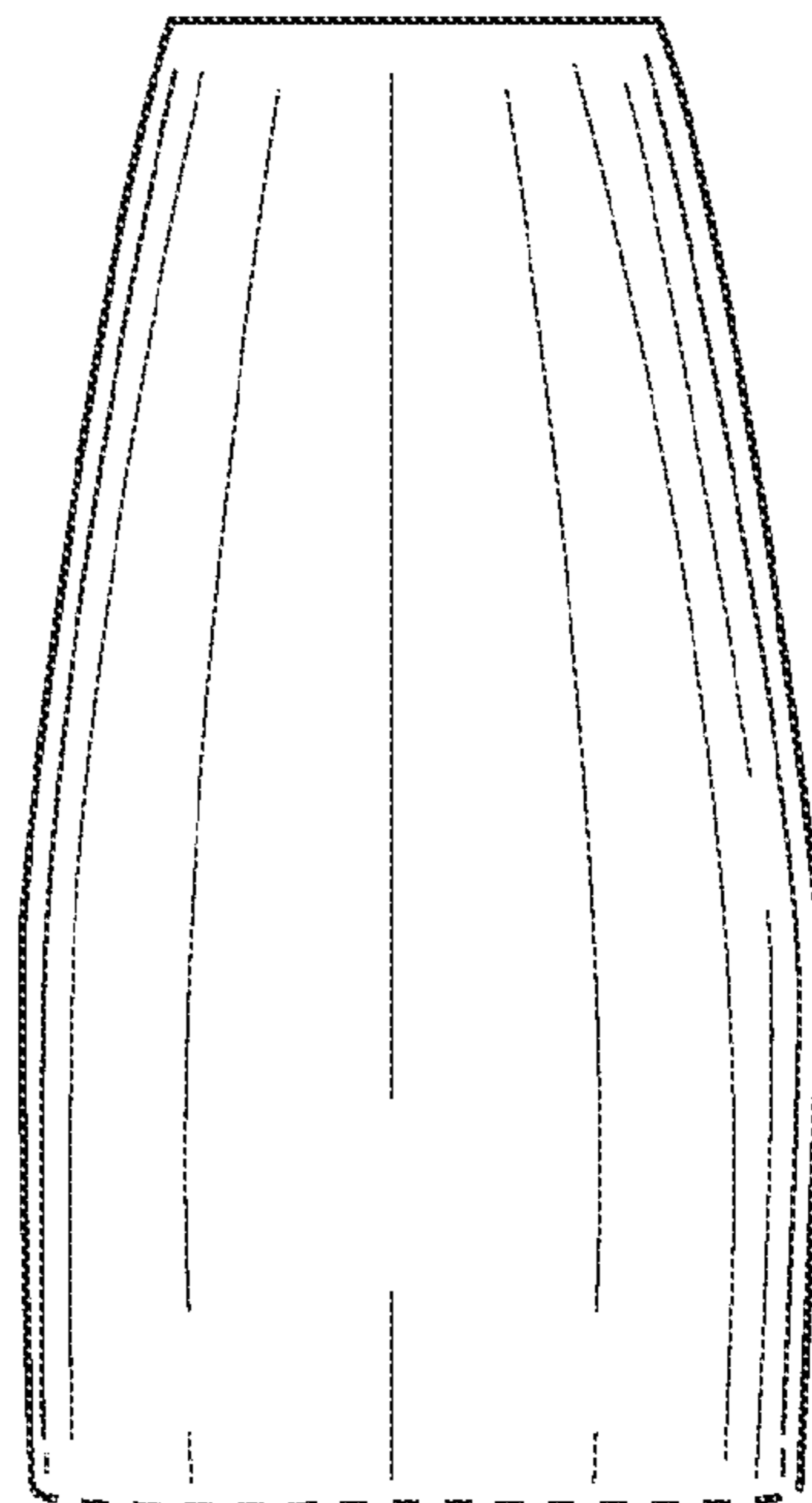

FIG. 5

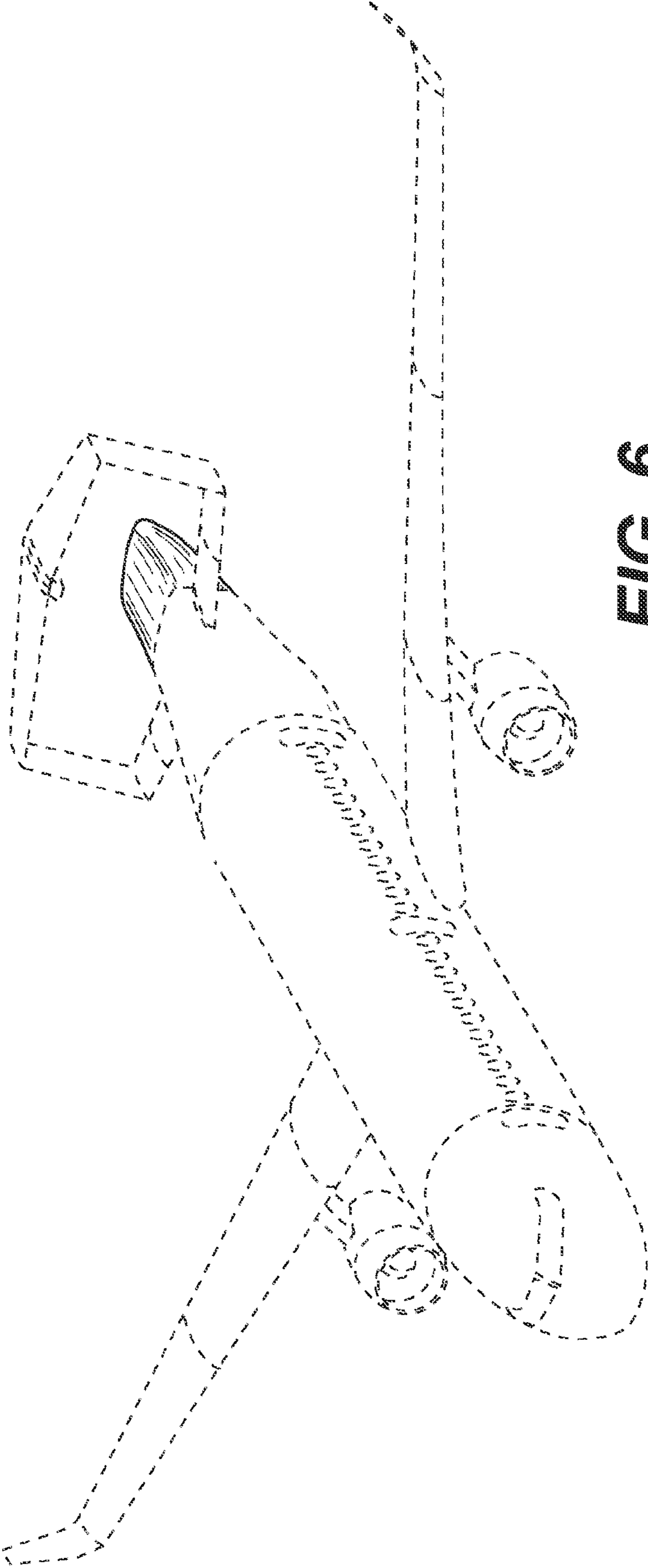

FIG. 6

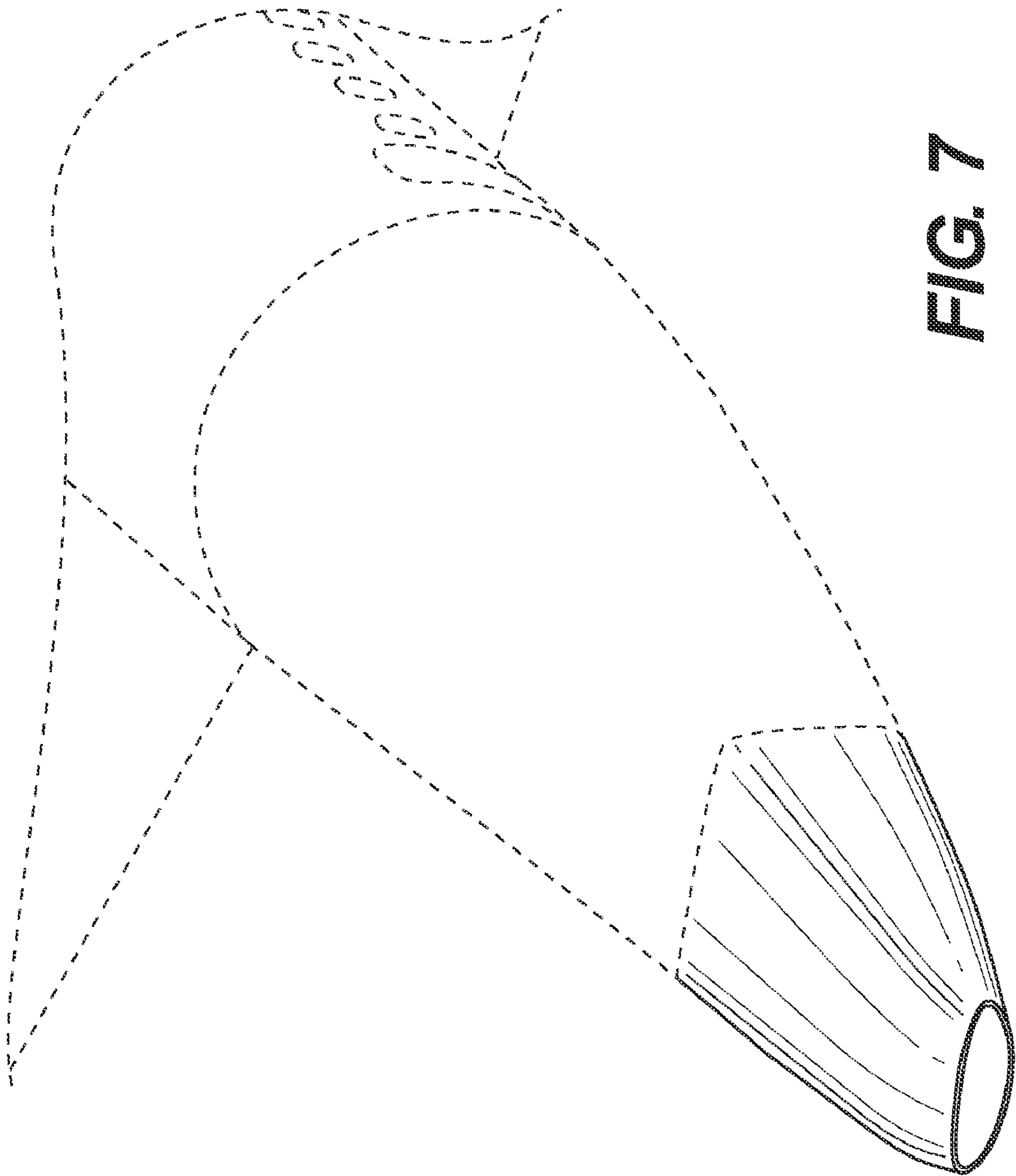

FIG. 7