



US00D581330S

(12) **United States Design Patent**
Stender

(10) **Patent No.:** **US D581,330 S**

(45) **Date of Patent:** **** Nov. 25, 2008**

(54) **EXPANSION MODULE FOR AN ELECTRONICALLY CONTROLLED BRAKE SYSTEM UNIT**

(75) **Inventor:** **Axel Stender**, Hameln (DE)

(73) **Assignee:** **WABCO GmbH**, Hannover (DE)

(**) **Term:** **14 Years**

(21) **Appl. No.:** **29/301,353**

(22) **Filed:** **Feb. 25, 2008**

(30) **Foreign Application Priority Data**

Aug. 30, 2007 (EM) 000781828

(51) **LOC (8) Cl.** **12-16**

(52) **U.S. Cl.** **D12/180**

(58) **Field of Classification Search** D12/179,
D12/180; D15/143, 148; 188/18 A, 71.5,
188/170; 303/7, 10, 20, 87, 113.5, 114.1,
303/119.2, 119.3

See application file for complete search history.

(56) **References Cited**

U.S. PATENT DOCUMENTS

5,288,141	A *	2/1994	Isshiki et al.	303/119.3
5,449,227	A *	9/1995	Steinberg et al.	303/119.2
5,945,743	A *	8/1999	Pattantyus et al.	307/10.1
6,186,603	B1 *	2/2001	Park	303/119.3
6,260,668	B1 *	7/2001	McClanahan	188/71.5
6,293,890	B1 *	9/2001	Kaku	475/230
6,312,061	B1 *	11/2001	Schliebe et al.	303/20
6,354,421	B1 *	3/2002	Mochizuki et al.	192/218
6,846,050	B2 *	1/2005	Inoue et al.	303/119.3
6,997,523	B1 *	2/2006	Banoczky et al.	303/87

D517,105	S *	3/2006	Negishi	D15/199
7,025,181	B2 *	4/2006	Affeldt et al.	188/170
D556,114	S *	11/2007	Hardesty Thompson ...	D12/218
7,357,466	B2 *	4/2008	Schluter	303/114.1
2004/0090115	A1 *	5/2004	Inoue et al.	303/119.3
2005/0056331	A1 *	3/2005	Schlitzkus et al.	137/884
2005/0166748	A1 *	8/2005	Schramm et al.	91/376 R
2005/0253451	A1 *	11/2005	Hinz et al.	303/119.3
2006/0237266	A1 *	10/2006	Powers	188/18 A
2007/0069574	A1 *	3/2007	Nazara	303/119.1
2008/0018171	A1 *	1/2008	Ohlig et al.	303/10
2008/0079309	A1 *	4/2008	Hatano et al.	303/113.5
2008/0156598	A1 *	7/2008	Nilsson	188/18 A

* cited by examiner

Primary Examiner—Sandra Snapp

Assistant Examiner—Patricia Palasik

(74) *Attorney, Agent, or Firm*—Kramer Levin Naftalis & Frankel LLP

(57) **CLAIM**

The ornamental design for an expansion module for an electronically controlled brake system unit, as shown and described.

DESCRIPTION

FIG. 1 is a front elevational view of an expansion module for an electronically controlled brake system unit showing the new design;

FIG. 2 is a right side elevational view thereof;

FIG. 3 is a top plan view thereof;

FIG. 4 is a bottom plan view thereof;

FIG. 5 is a rear elevational view thereof; and,

FIG. 6 is a left side elevational view thereof.

1 Claim, 6 Drawing Sheets

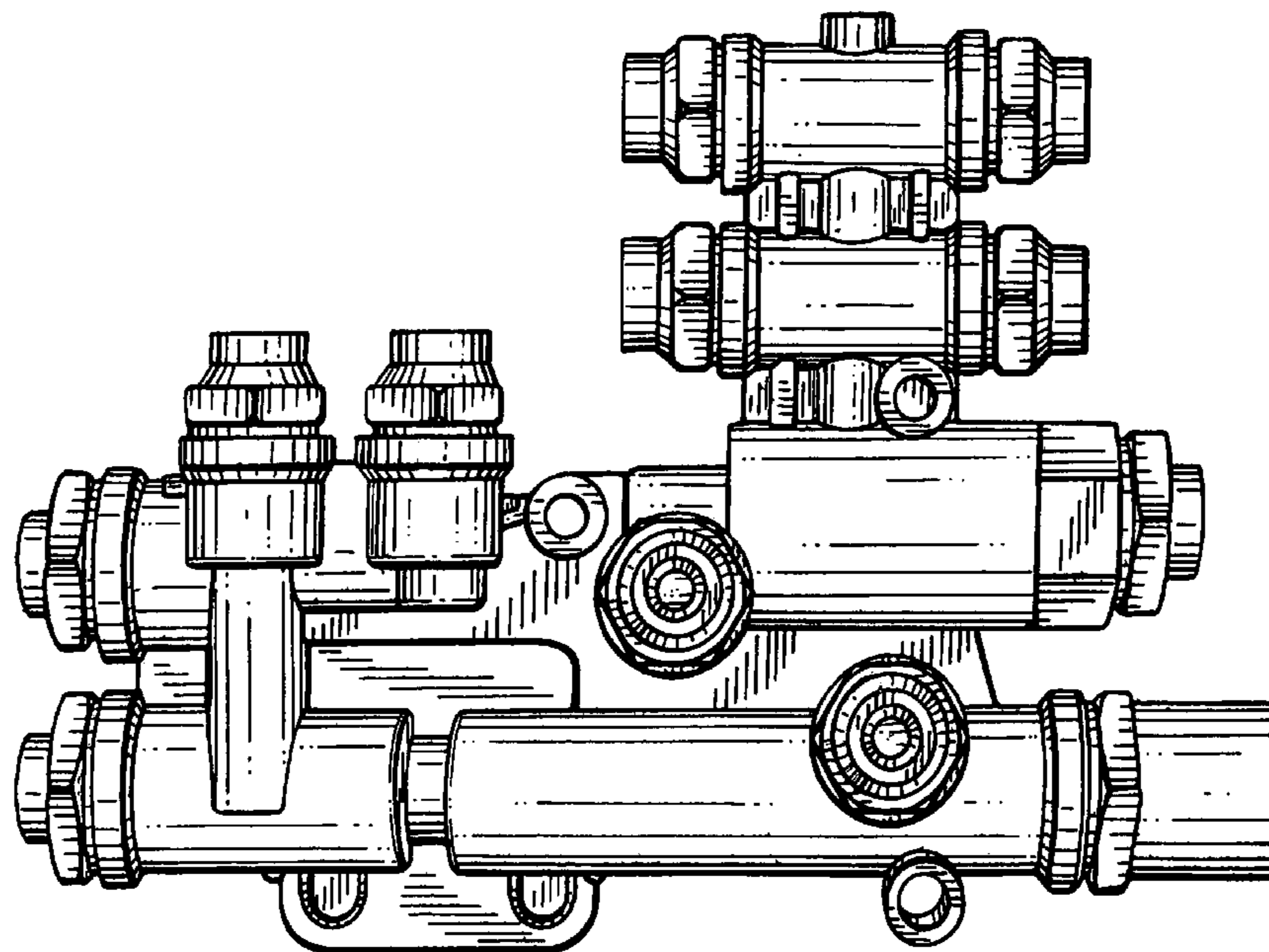

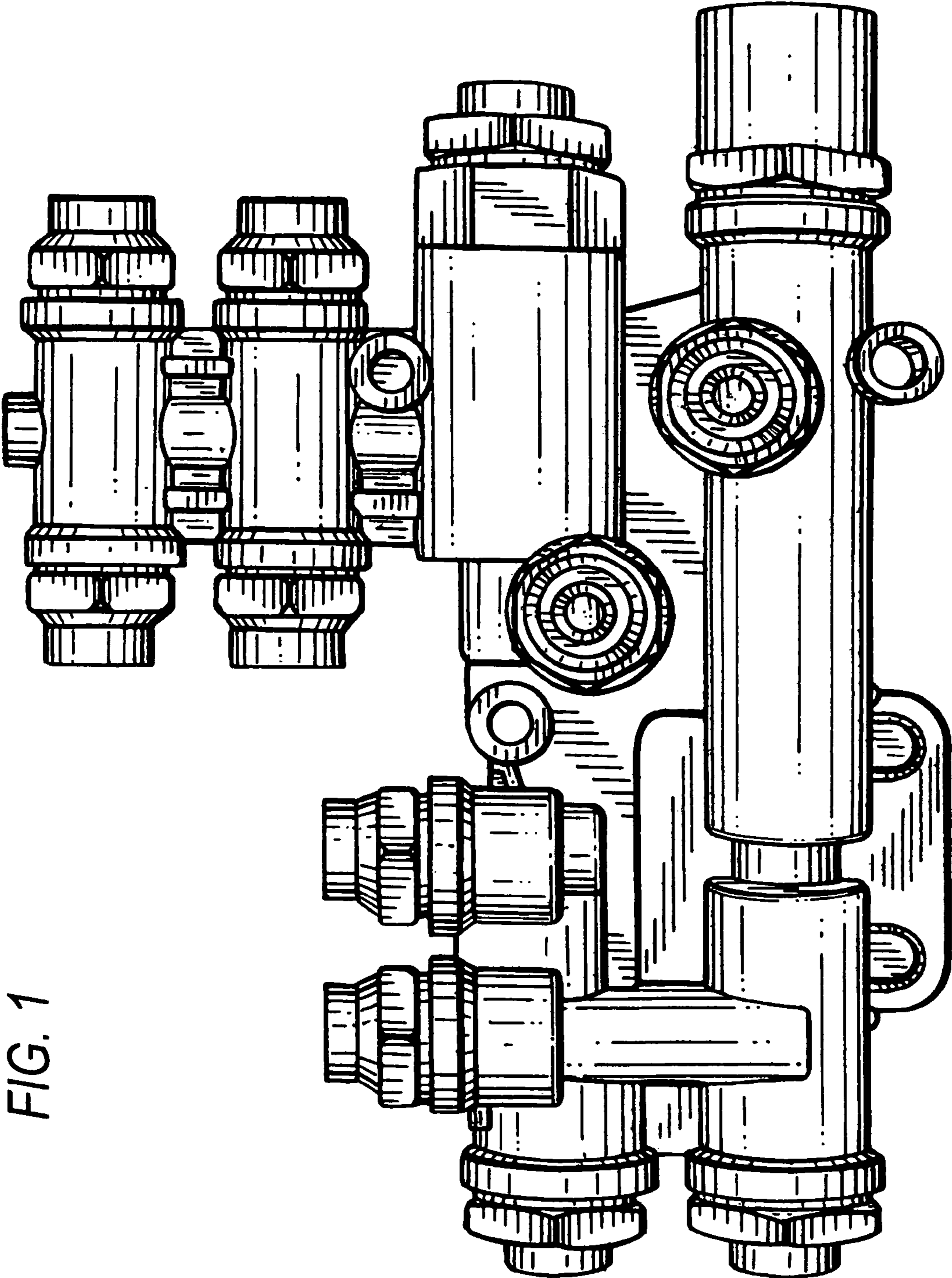

FIG. 1

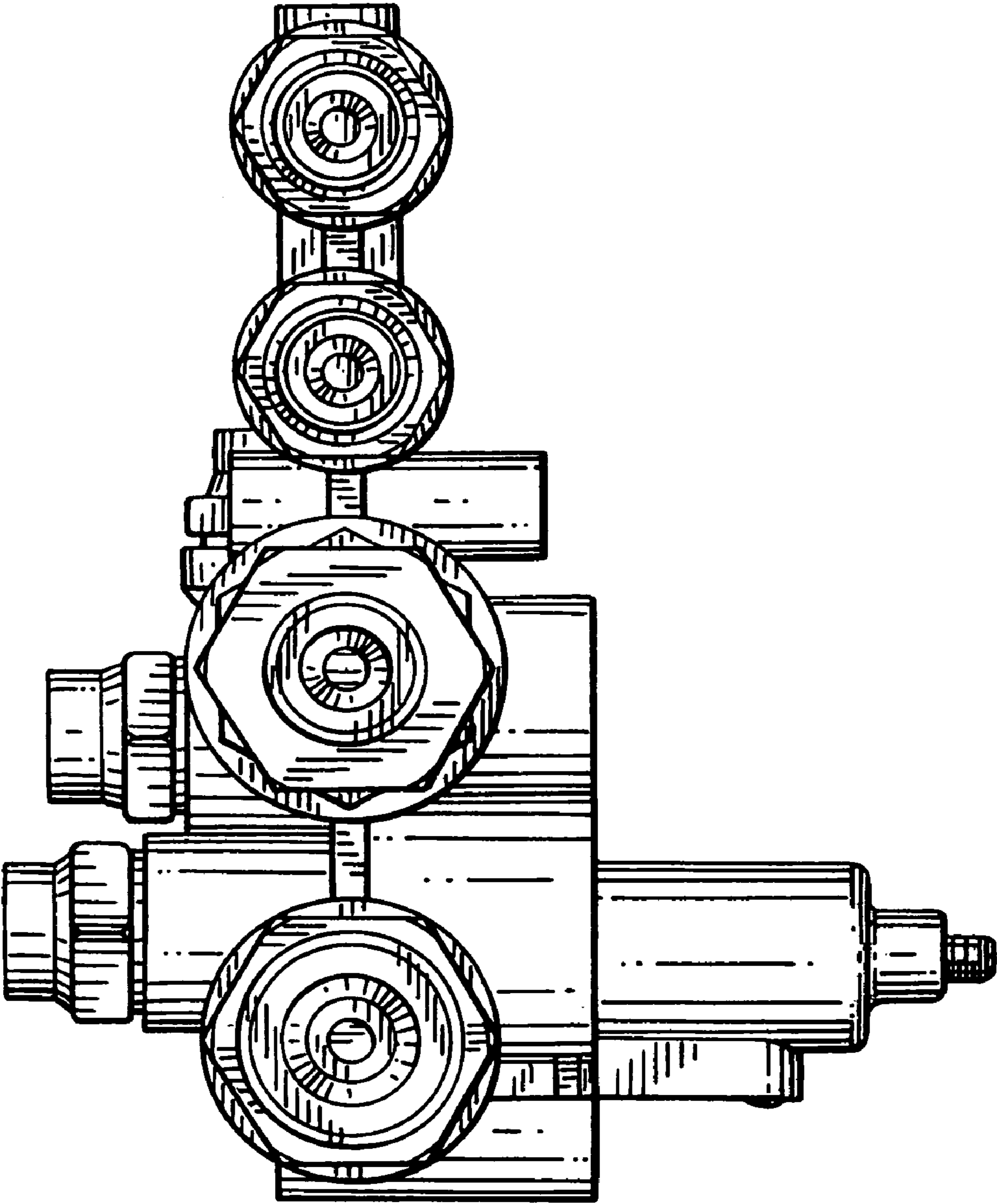
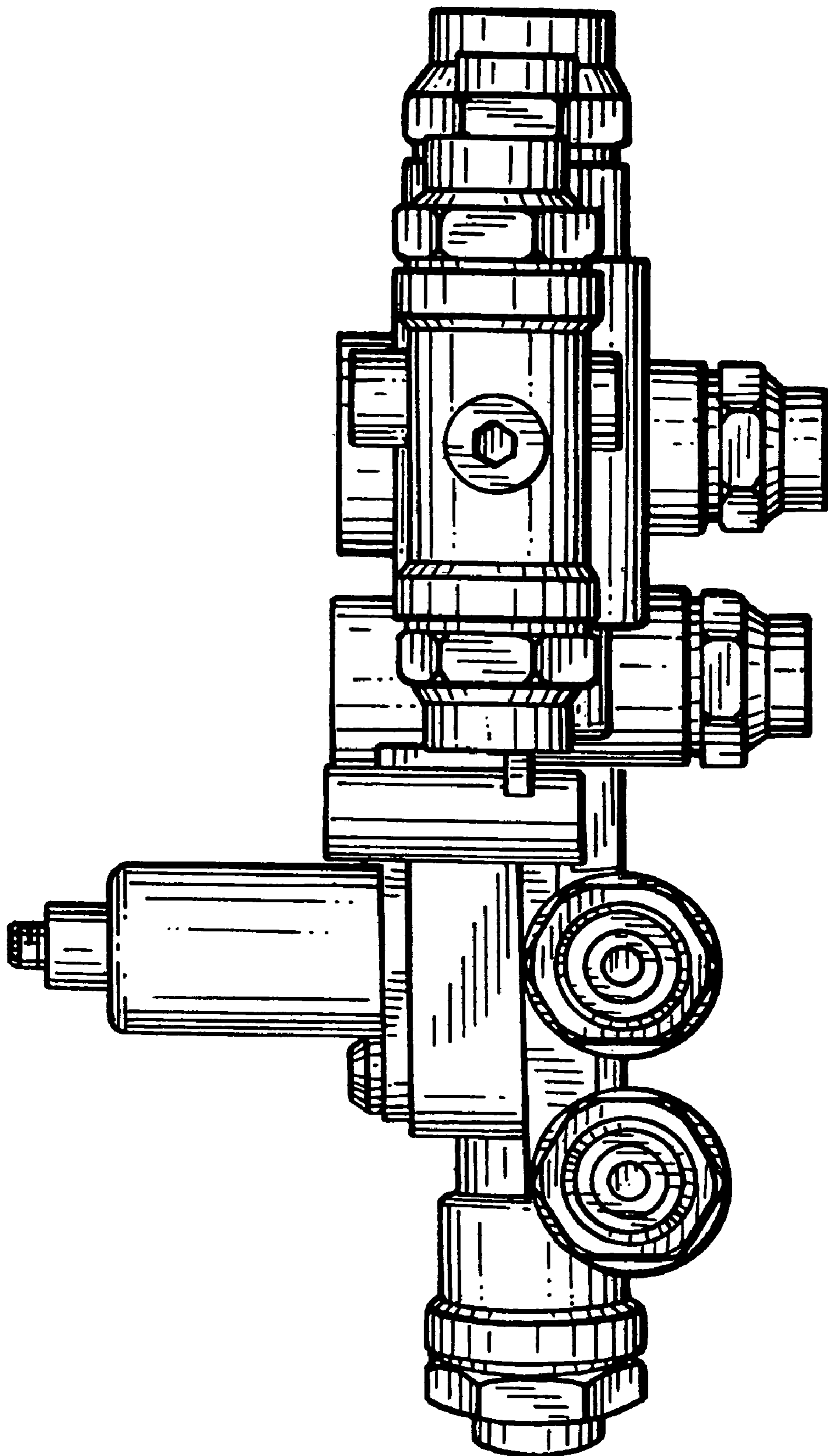

FIG. 2

FIG. 3



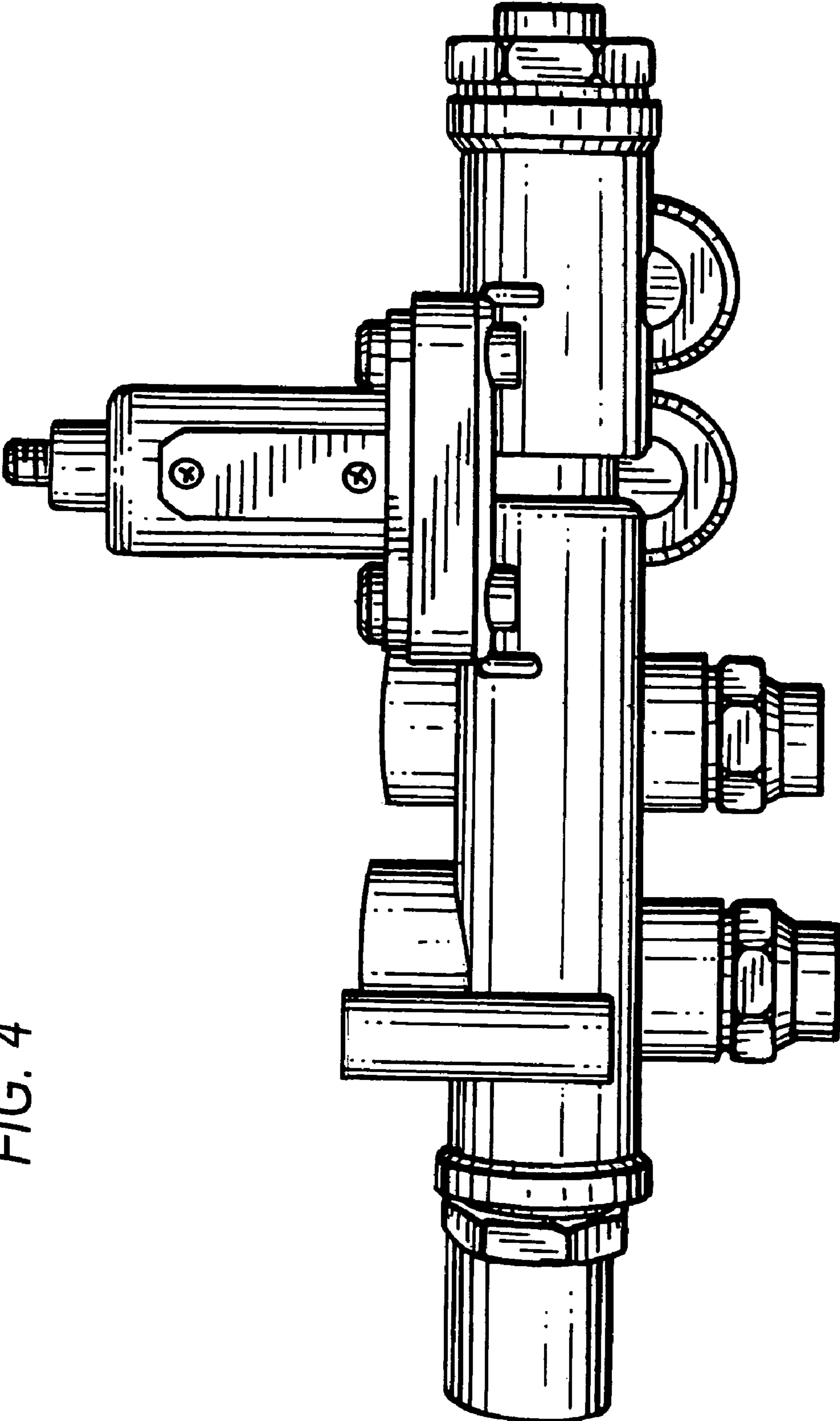
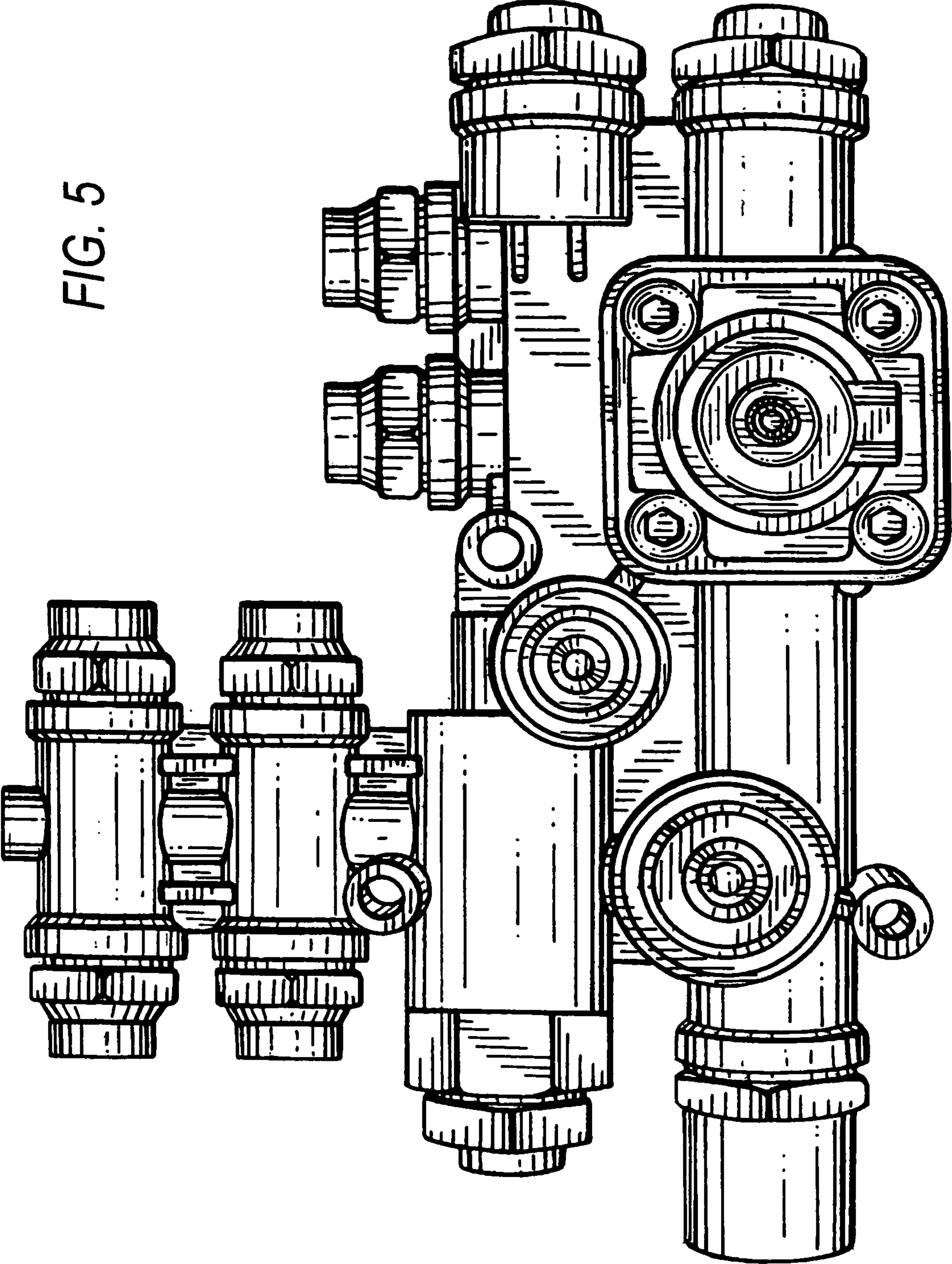

FIG. 4

FIG. 5



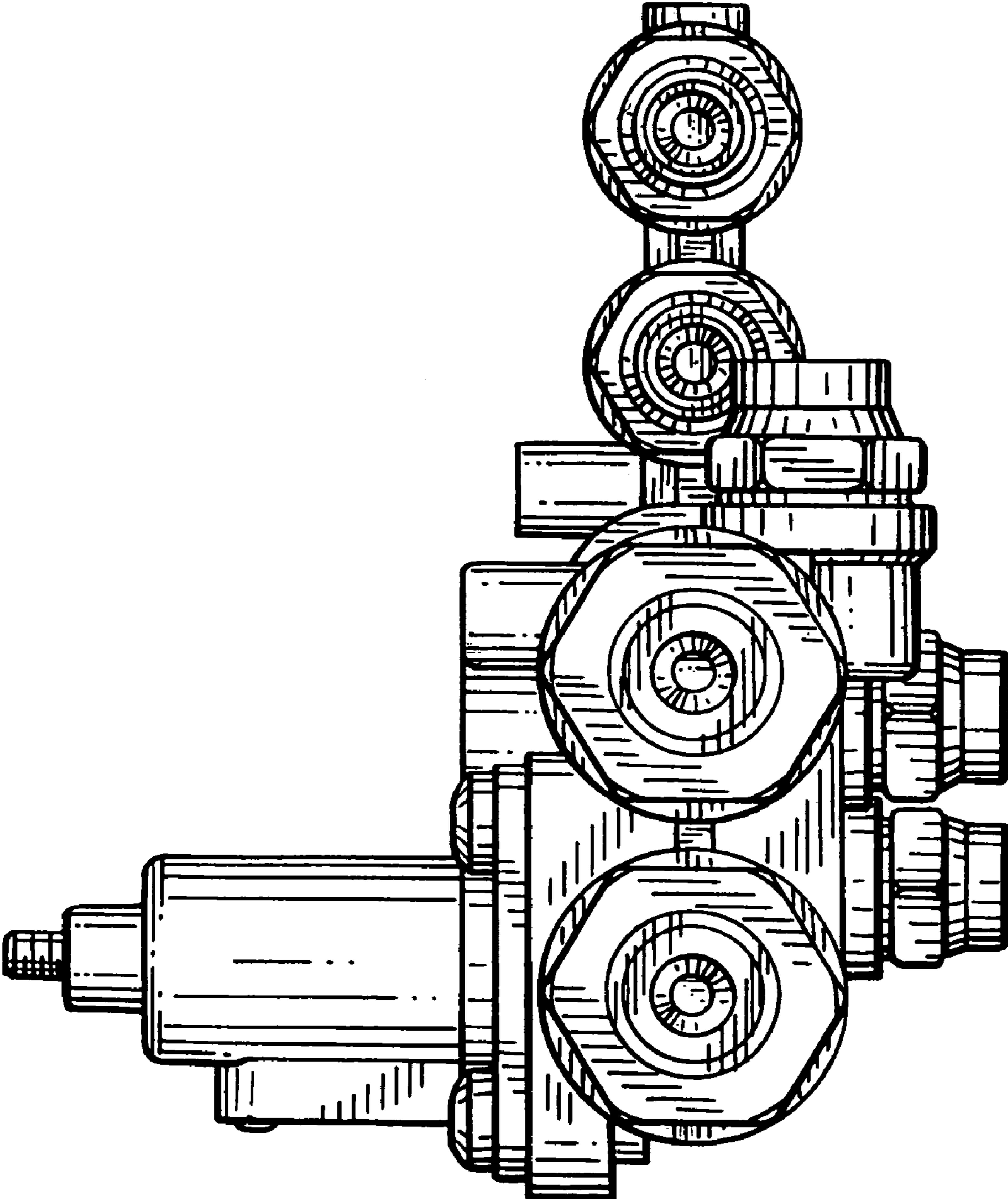

FIG. 6