



US00D581322S

(12) **United States Design Patent**
Madden

(10) **Patent No.:** **US D581,322 S**
(45) **Date of Patent:** **** Nov. 25, 2008**

(54) **MOTORCYCLE INNER PRIMARY COVER**

(75) Inventor: **Kenneth E. Madden**, Somerset, WI (US)

(73) Assignee: **Kuryakyn Holdings, Inc.**, Somerset, WI (US)

(**) Term: **14 Years**

(21) Appl. No.: **29/294,416**

(22) Filed: **Jan. 10, 2008**

(51) **LOC (8) Cl.** **12-11**

(52) **U.S. Cl.** **D12/126**

(58) **Field of Classification Search** D12/110, D12/114, 126, 127; 280/288.4, 304.3; 180/219, 180/231; 123/195 C, 198 E, 198 R, 195 A, 123/195 R, 196 P; D15/1-5, 149; 474/144, 474/146; 290/38 C, 38 R; 74/6, 7 A, 606 R
See application file for complete search history.

(56) **References Cited**

U.S. PATENT DOCUMENTS

D570,746 S * 6/2008 Arndt et al. D12/126

OTHER PUBLICATIONS

Custom Chrome® 2004 catalog, chrome inner primary covers on p. 12.07.*

Motorcycle Warehouse 2005 catalog, inner primary covers on p. 7-93.*

Kuryakyn Holdings, Inc. 2003 Catalog, (2 pgs.) (Cover page and p. 57).

* cited by examiner

Primary Examiner—Ian Simmons

Assistant Examiner—Linda Brooks

(74) *Attorney, Agent, or Firm*—Dicke, Billig & Czaja, PLLC

(57) **CLAIM**

The ornamental design for a motorcycle inner primary cover, as shown and described.

DESCRIPTION

FIG. 1 is a top perspective view of the motorcycle inner primary cover of the present invention.

FIG. 2 is a front side elevation view thereof.

FIG. 3 is a rear side elevation view thereof.

FIG. 4 is a top plan view thereof.

FIG. 5 is a bottom plan view thereof.

FIG. 6 is a left side elevation view thereof; and,

FIG. 7 is a right side elevation view thereof.

Those portions of the motorcycle inner primary cover shown broken lines form no part of the claimed design. The broken lines shown on the rear surfaces indicate that the rear surfaces of the motorcycle inner primary cover form no part of the claimed design.

1 Claim, 6 Drawing Sheets

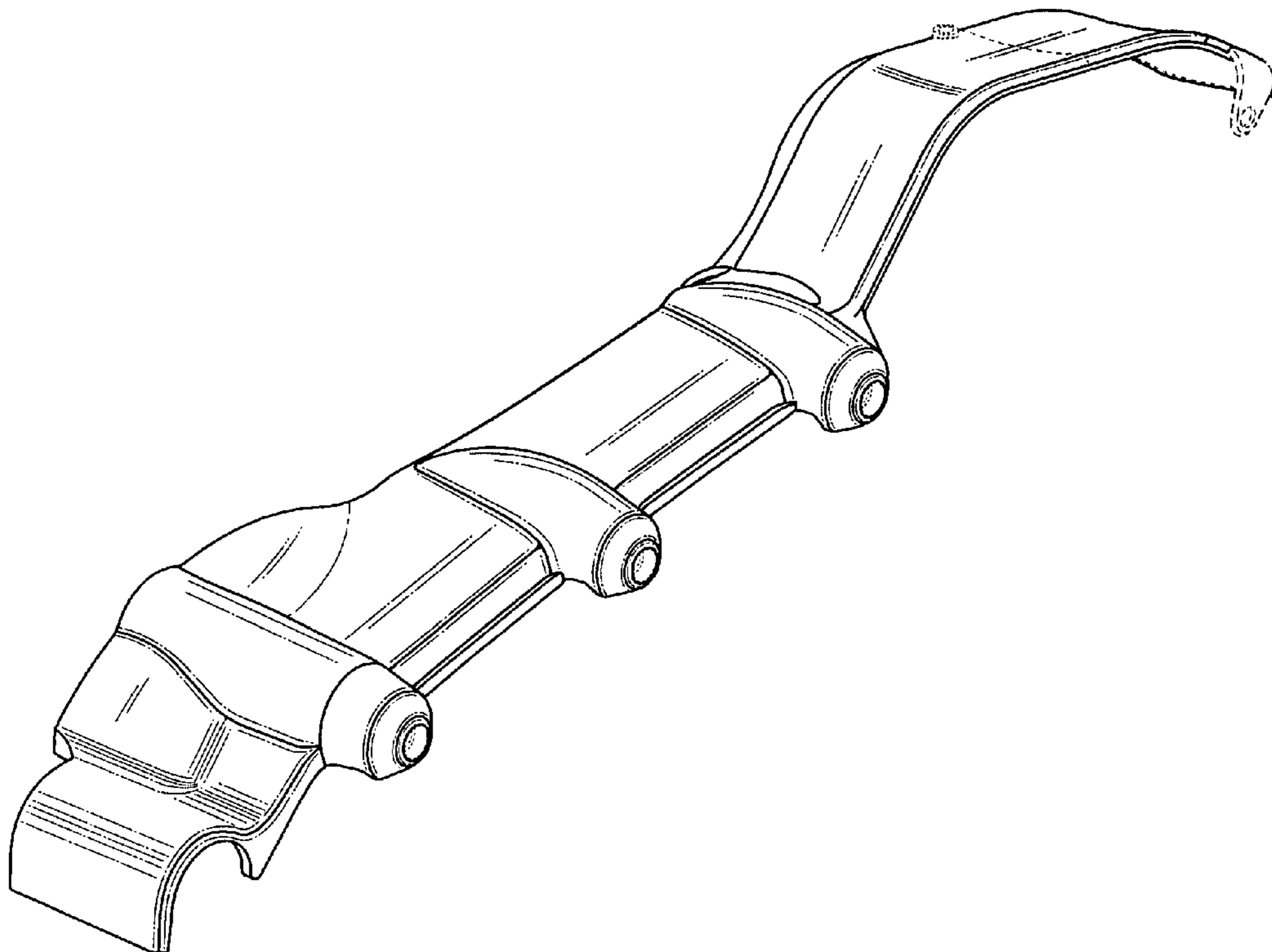

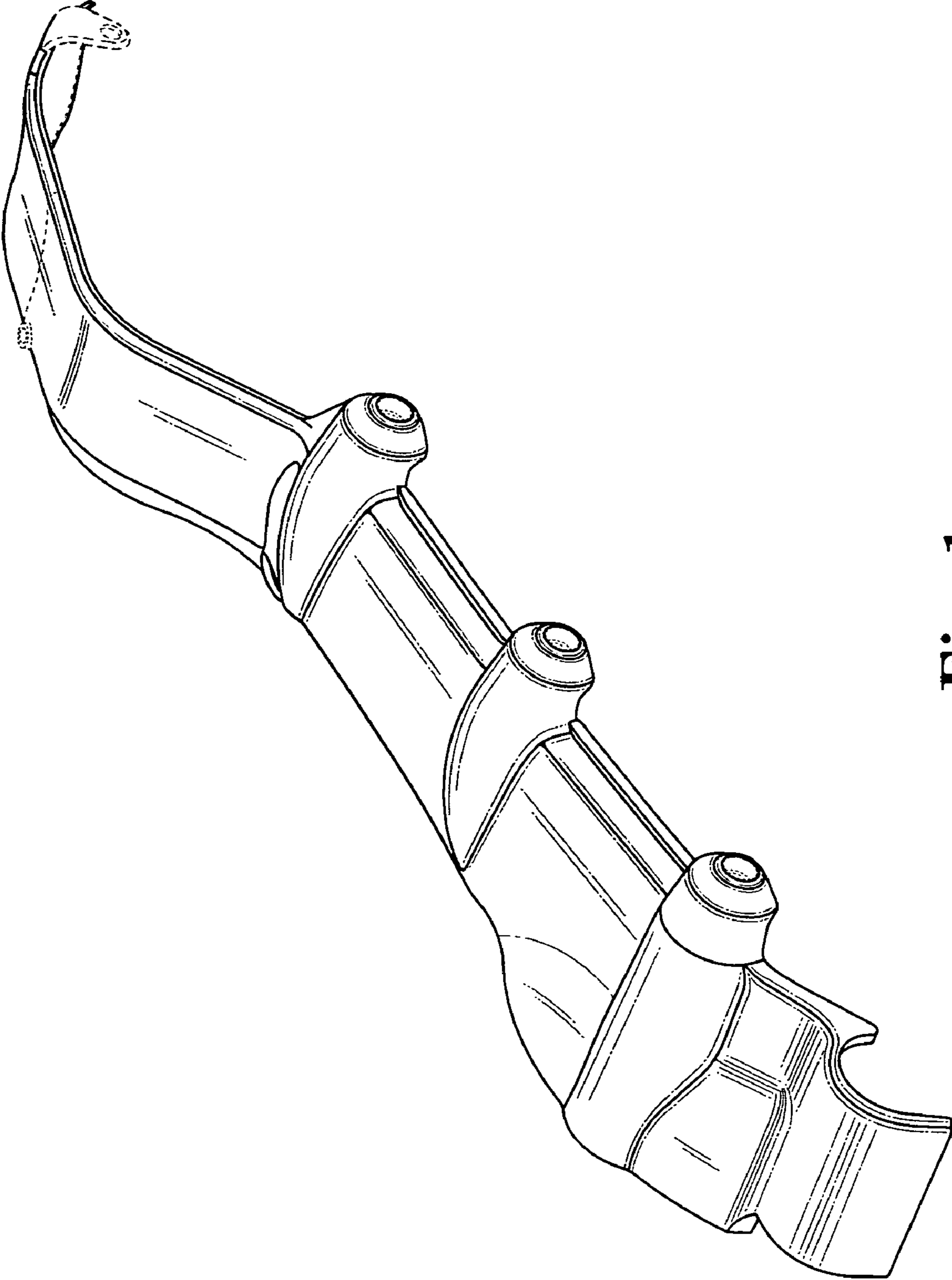

Fig. 1

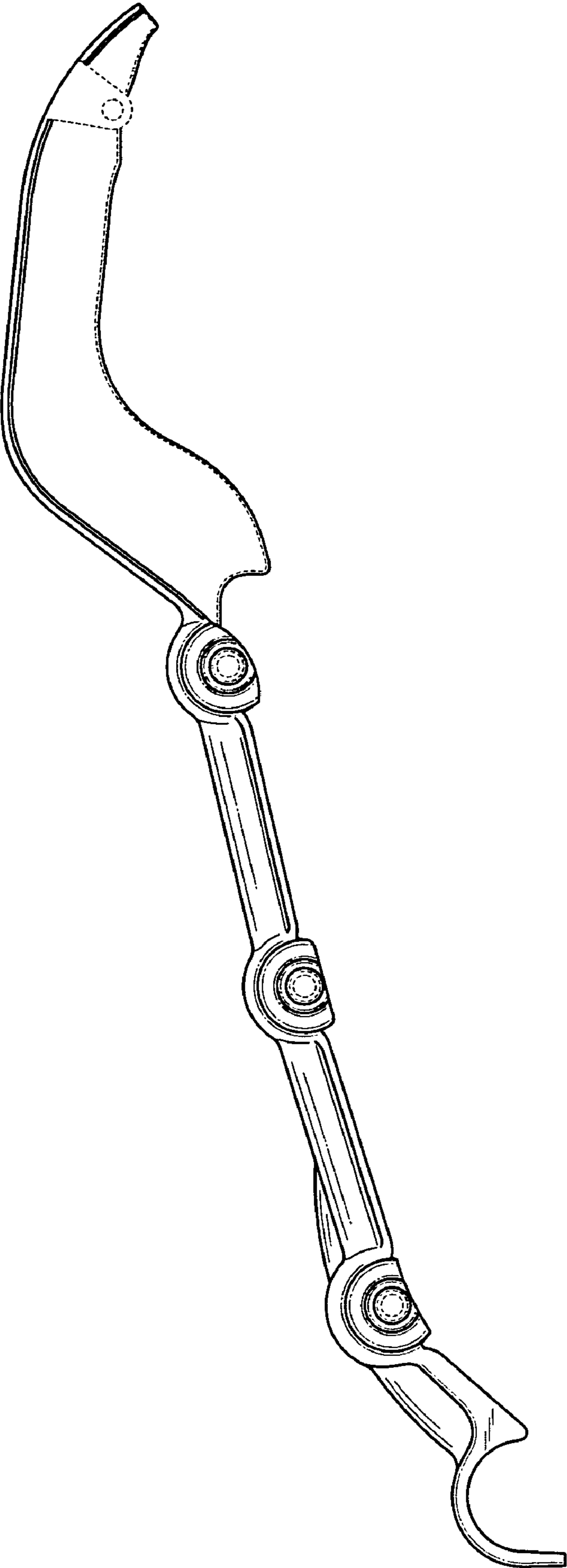

Fig. 2

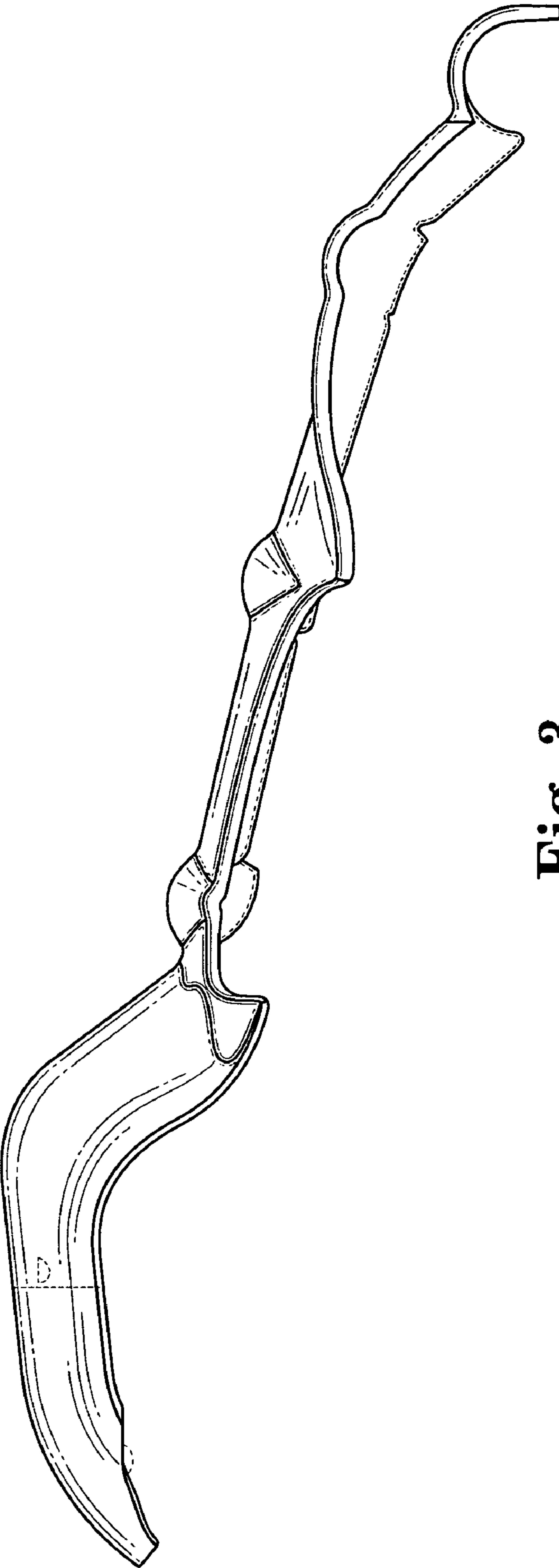

Fig. 3

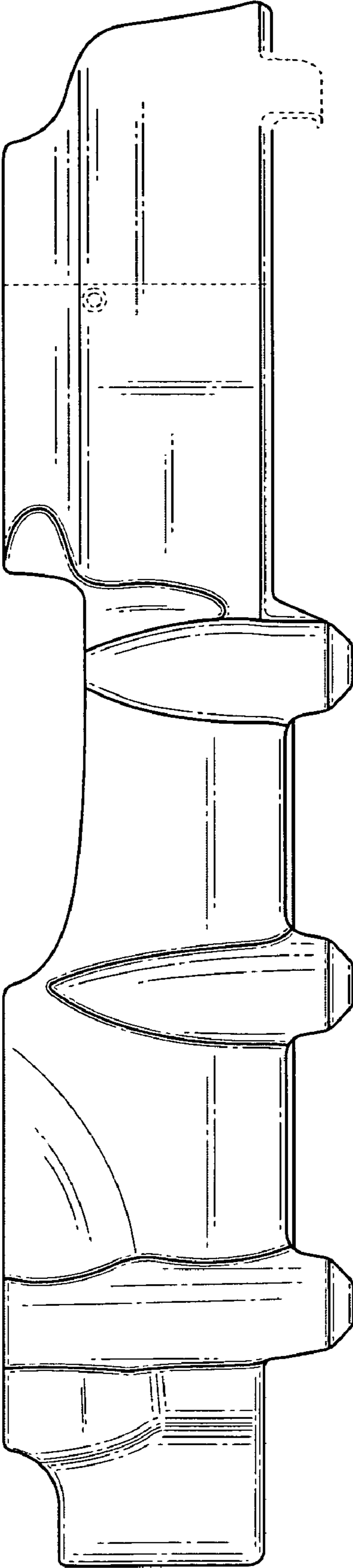

Fig. 4

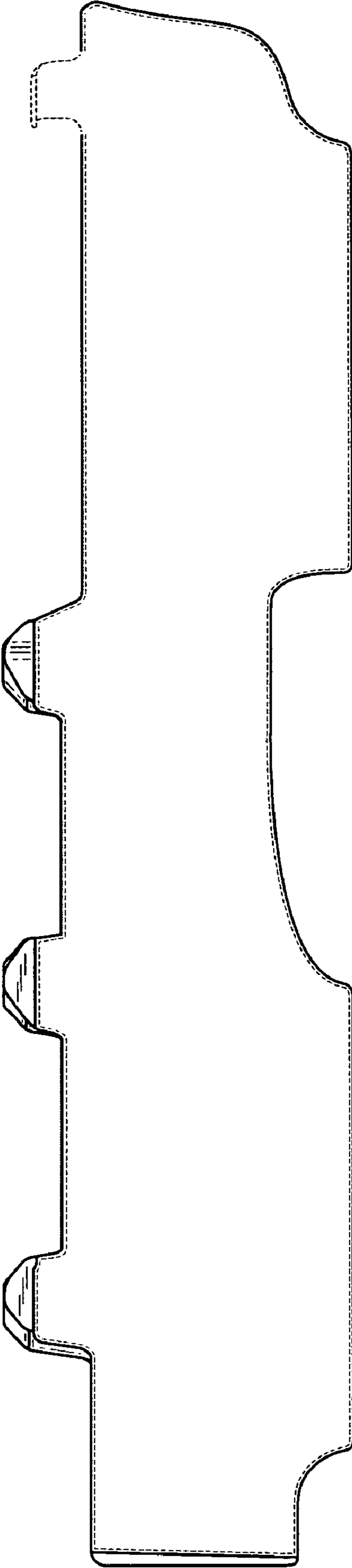

Fig. 5

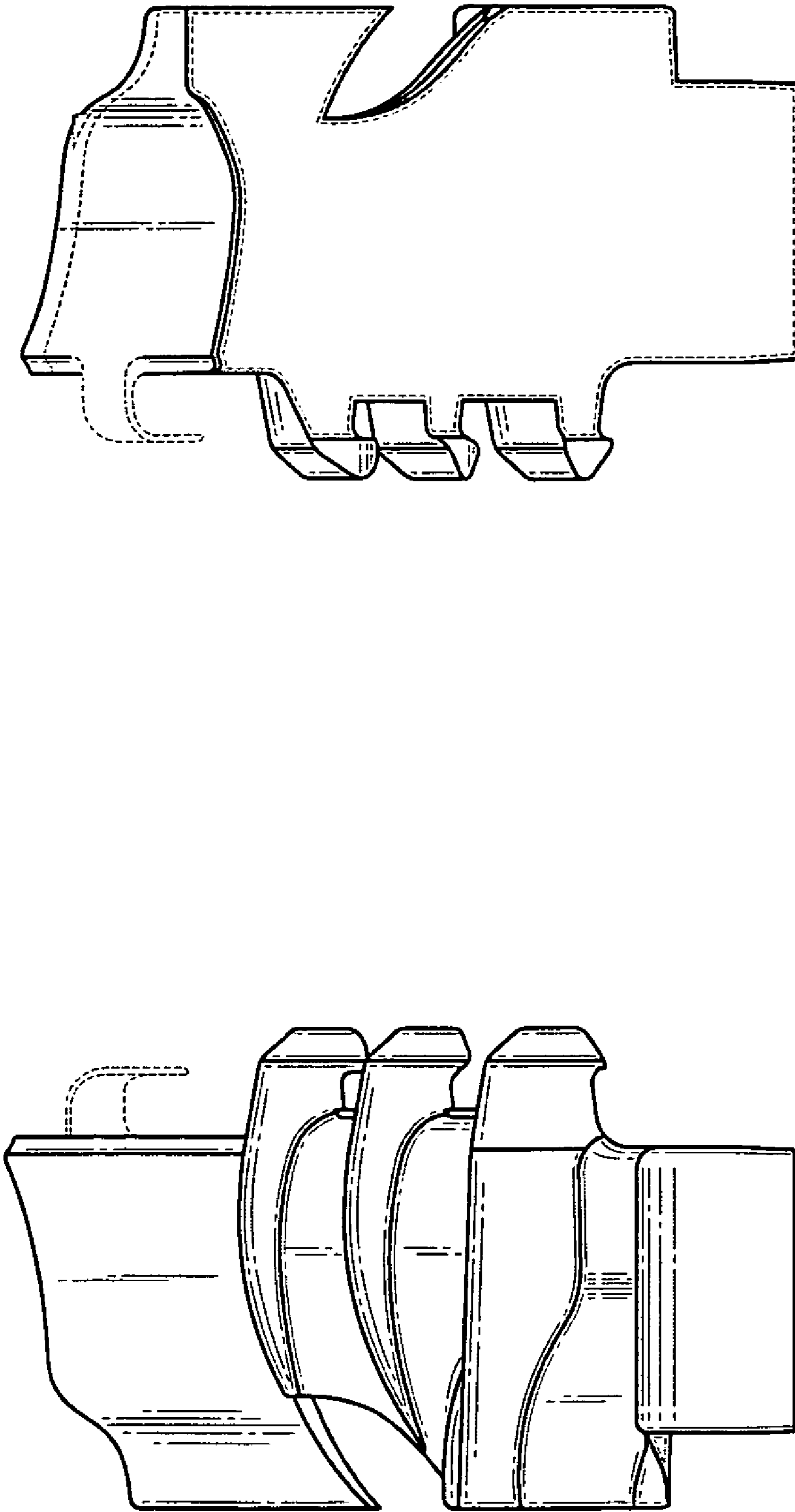

Fig. 7

Fig. 6