



US00D581320S

(12) **United States Design Patent**
Longpre et al.

(10) **Patent No.:** **US D581,320 S**

(45) **Date of Patent:** **** Nov. 25, 2008**

(54) **VEHICLE UPPER BODY ASSEMBLY**

(75) Inventors: **Guillaume Longpre**, Granby (CA);
Denys Lapointe, St-Bruno (CA);
Martin Portelance, Sherbrooke (CA);
Etienne Guay, Orford (CA); **Nicolas Deluy**, Sherbrooke (CA)

(73) Assignee: **Bombardier Recreational Products Inc.**, Valcourt (CA)

(**) Term: **14 Years**

(21) Appl. No.: **29/284,480**

(22) Filed: **Sep. 9, 2007**

Related U.S. Application Data

(63) Continuation-in-part of application No. 29/279,940, filed on May 11, 2007.

(51) **LOC (8) Cl.** **12-11**

(52) **U.S. Cl.** **D12/107**

(58) **Field of Classification Search** D12/107,
D12/110, 112, 85; 180/16, 210-217, 219,
180/220, 225, 229; 280/202, 282, 288.1-288.4;
296/78.1, 193.01, 193.05, 193.09, 193.11,
296/181.1, 181.4

See application file for complete search history.

(56) **References Cited**

U.S. PATENT DOCUMENTS

D175,558 S *	9/1955	Laub	D12/110
4,423,795 A *	1/1984	Winchell et al.	180/215
D292,565 S *	11/1987	Badsey	D12/85
6,446,744 B2	9/2002	Wubbolts et al.	
6,604,594 B2	8/2003	Wubbolts et al.	
6,655,487 B2	12/2003	Mallette et al.	
D485,788 S	1/2004	Guay et al.	
6,866,110 B2	3/2005	Mallette et al.	
6,948,581 B2	9/2005	Fecteau et al.	
D529,841 S *	10/2006	Vey	D12/110
D547,242 S *	7/2007	Lambri	D12/110
D547,701 S *	7/2007	Vey	D12/110

2001/0040064 A1	11/2001	Girouard et al.	
2002/0129984 A1	9/2002	Wubbolts et al.	
2003/0221890 A1	12/2003	Fecteau et al.	
2003/0221891 A1	12/2003	Fecteau et al.	
2004/0032120 A1	2/2004	Vaisanen et al.	
2004/0035623 A1	2/2004	Fecteau et al.	
2004/0035624 A1	2/2004	Fecteau et al.	
2004/0035625 A1	2/2004	Talbot et al.	
2004/0035626 A1	2/2004	Girouard et al.	
2004/0129473 A1	7/2004	Talbot et al.	
2004/0129483 A1	7/2004	Girouard et al.	
2004/0140140 A1	7/2004	Guay et al.	
2005/0039967 A1	2/2005	Aube et al.	
2007/0075514 A1 *	4/2007	Saiki	280/124.103

OTHER PUBLICATIONS

French Design Application No. 025060, published Feb. 14, 2003 (the certified document is filed in parent U.S. Appl. No. 29/279,940).*
FIG. 18 of U.S. Appl. No. 29/156,028, now U.S. No. D485,788 (figure cancelled during prosecution).

* cited by examiner

Primary Examiner—Cathron Brooks

Assistant Examiner—Linda Brooks

(74) *Attorney, Agent, or Firm*—Osler, Hoskin & Harcourt LLP

(57) **CLAIM**

The ornamental design for a vehicle upper body assembly, as shown and described.

DESCRIPTION

FIG. 1 is a perspective view from the front and left side of a vehicle upper body assembly according to our design;

FIG. 2 is a front elevational view thereof;

FIG. 3 is a rear elevational view thereof;

FIG. 4 is a left side elevational view thereof, the right side elevational view being a mirror image thereof;

FIG. 5 is a top plan view thereof;

FIG. 6 is a perspective view from the front and left side of the vehicle upper body assembly shown in FIG. 1, with more of the unclaimed features of a road vehicle shown in dashed broken lines;

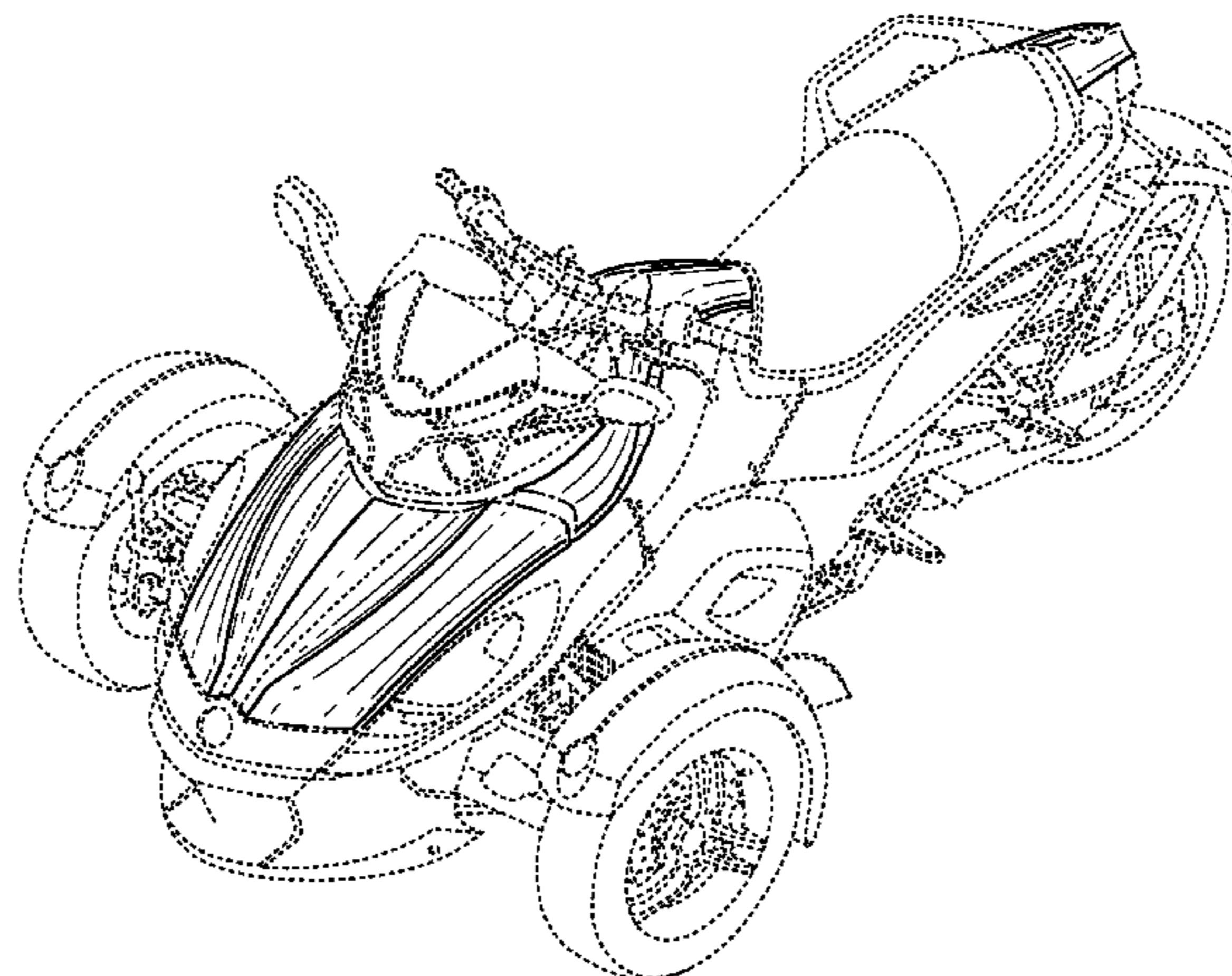

FIG. 7 is a front elevational view of the vehicle upper body assembly shown in FIG. 2, with more of the unclaimed features of a road vehicle shown in dashed broken lines;

FIG. 8 is a rear elevational view of the vehicle upper body assembly shown in FIG. 3, with more of the unclaimed features of a road vehicle shown in dashed broken lines;

FIG. 9 is a left side elevational view of the vehicle upper body assembly shown in FIG. 4, with more of the unclaimed features of a road vehicle shown in dashed broken lines, the right side elevational view being a mirror image thereof;

FIG. 10 is a top plan view of the vehicle upper body assembly shown in FIG. 5, with more of the unclaimed features of a road vehicle shown in dashed broken lines;

FIG. 11 is a perspective view from the front and left side of the vehicle upper body assembly according to our design shown in FIG. 1, without dashed broken lines;

FIG. 12 is a front elevational view of the vehicle upper body assembly shown in FIG. 11;

FIG. 13 is a rear elevational view of the vehicle upper body assembly shown in FIG. 11;

FIG. 14 is a left side elevational view of the vehicle upper body assembly shown in FIG. 11, the right side elevational view being a mirror image thereof; and,

FIG. 15 is a top plan view of the vehicle upper body assembly shown in FIG. 11.

Throughout the Figures, the dashed broken lines represent environmental matter and/or unclaimed portions of the road vehicle and form no part of the claimed design. The dash-dot broken lines represent the boundary between claimed and unclaimed areas and form no part of the claimed design. Portions of the article not shown in the drawings form no part of the claimed design.

1 Claim, 12 Drawing Sheets

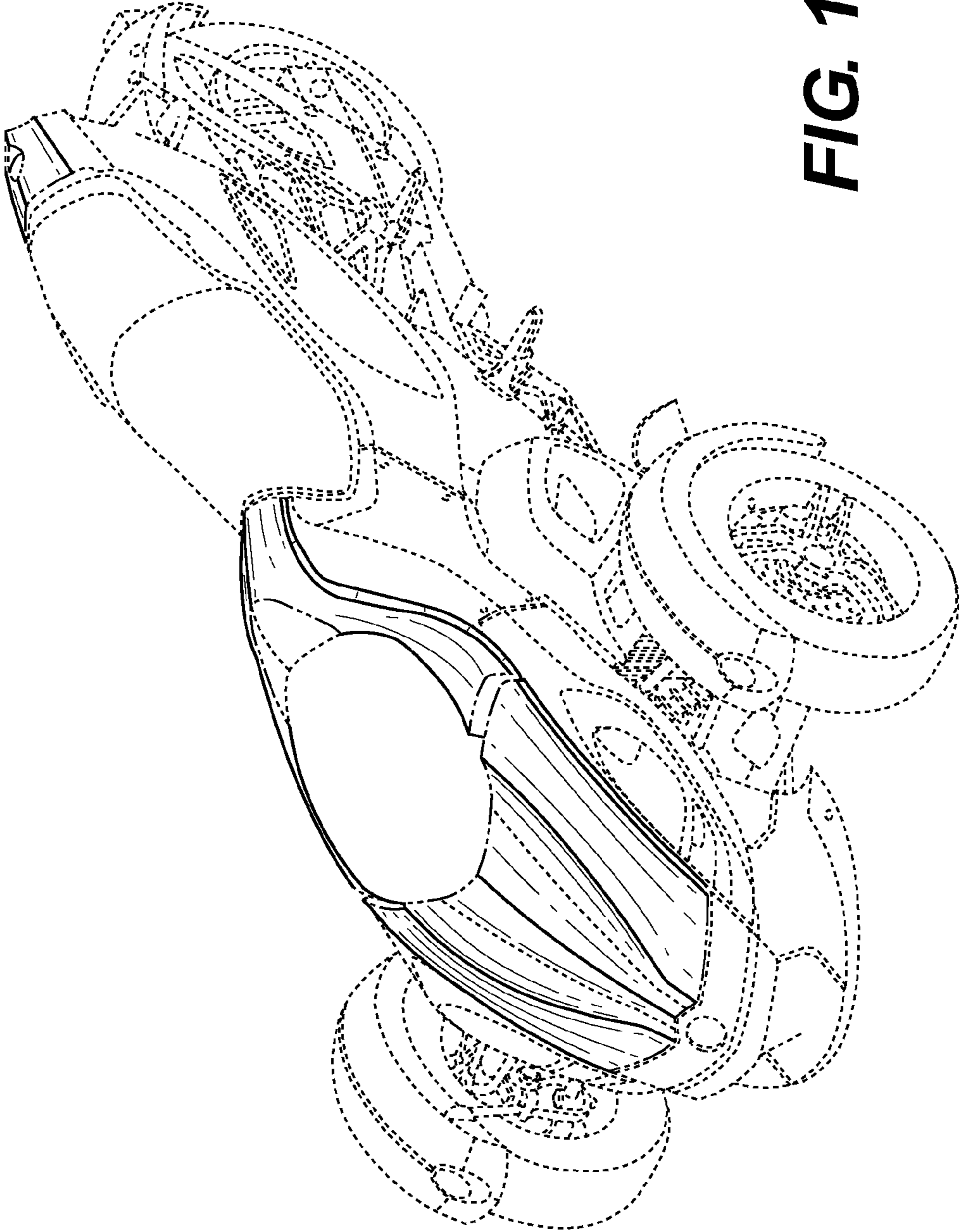

FIG. 1

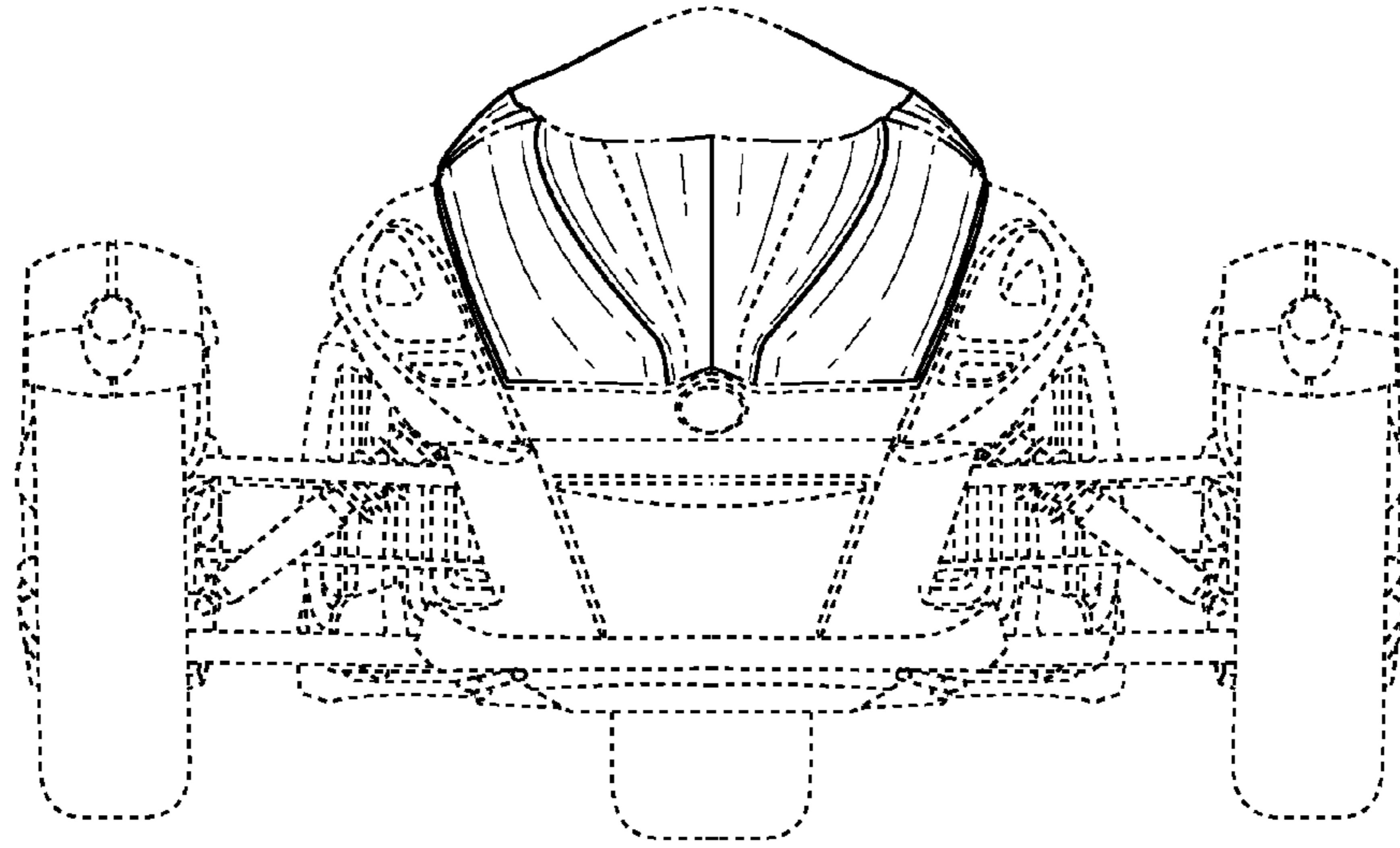

FIG. 2

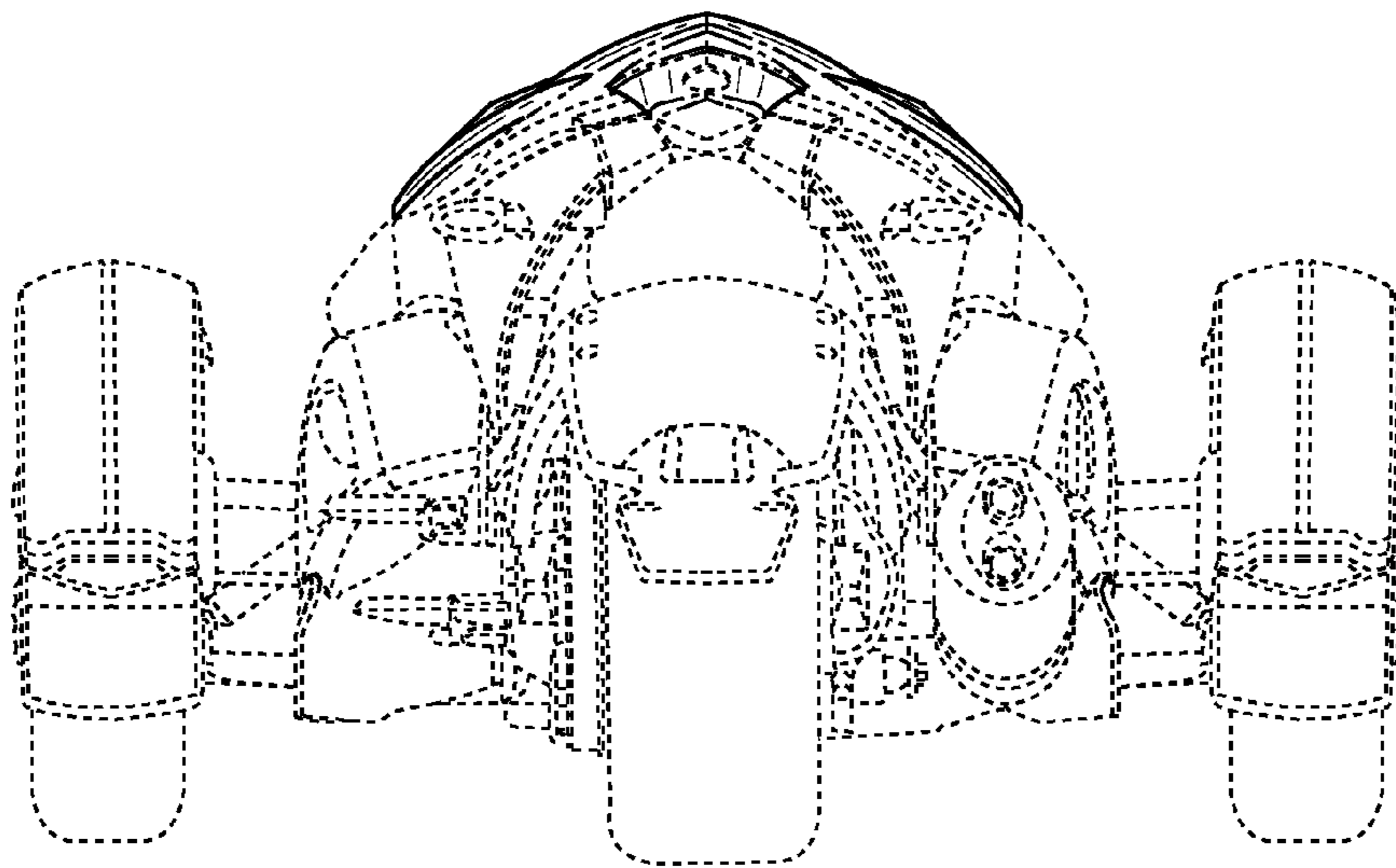

FIG. 3

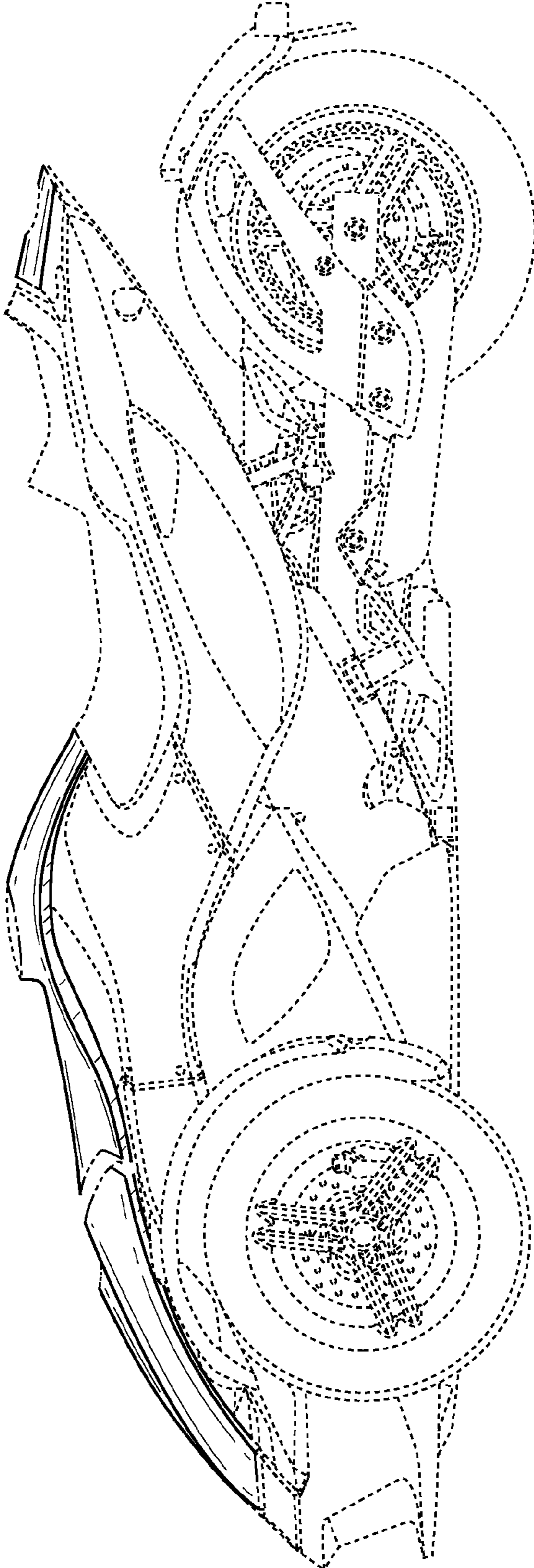

FIG. 4

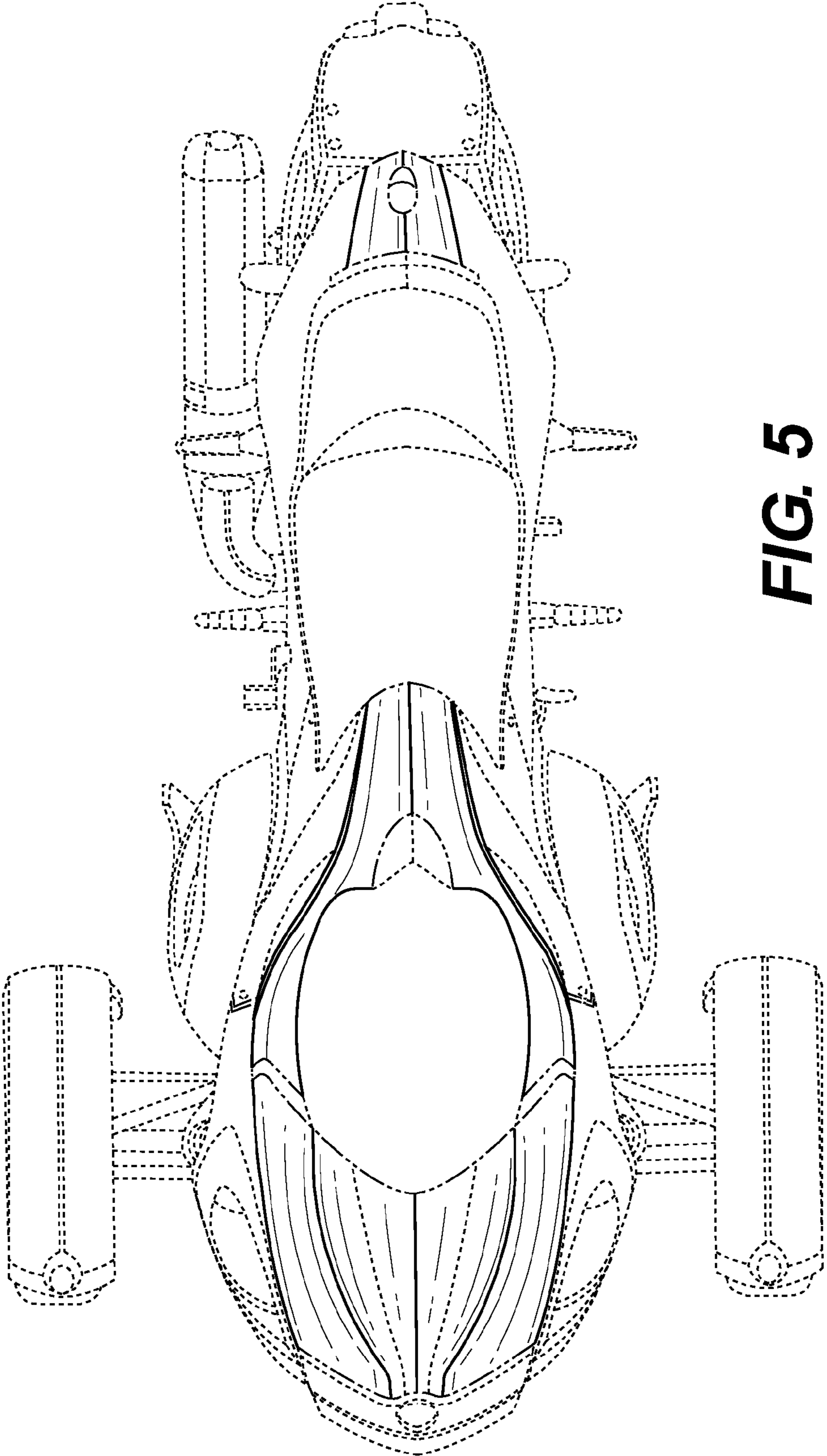

FIG. 5

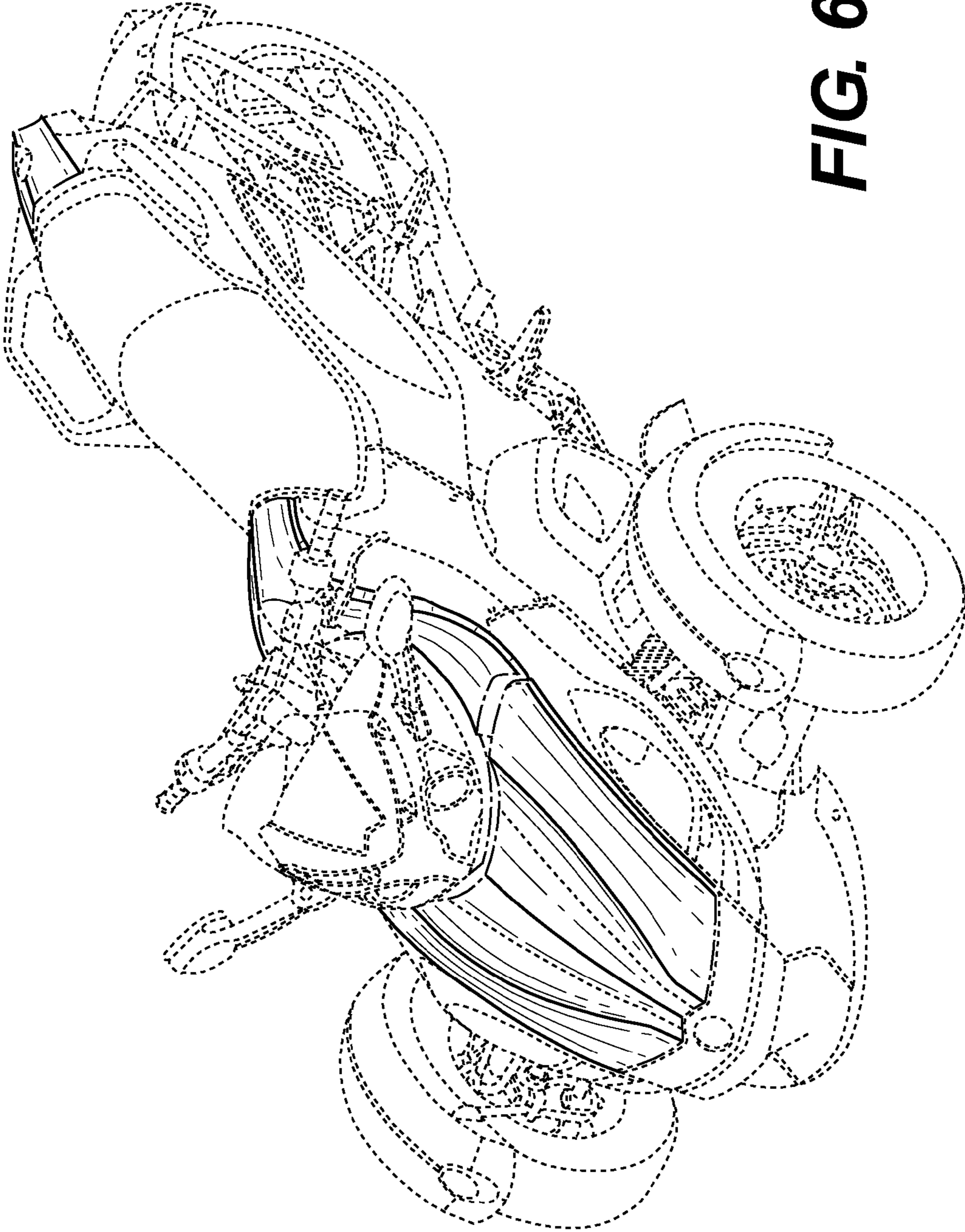

FIG. 6

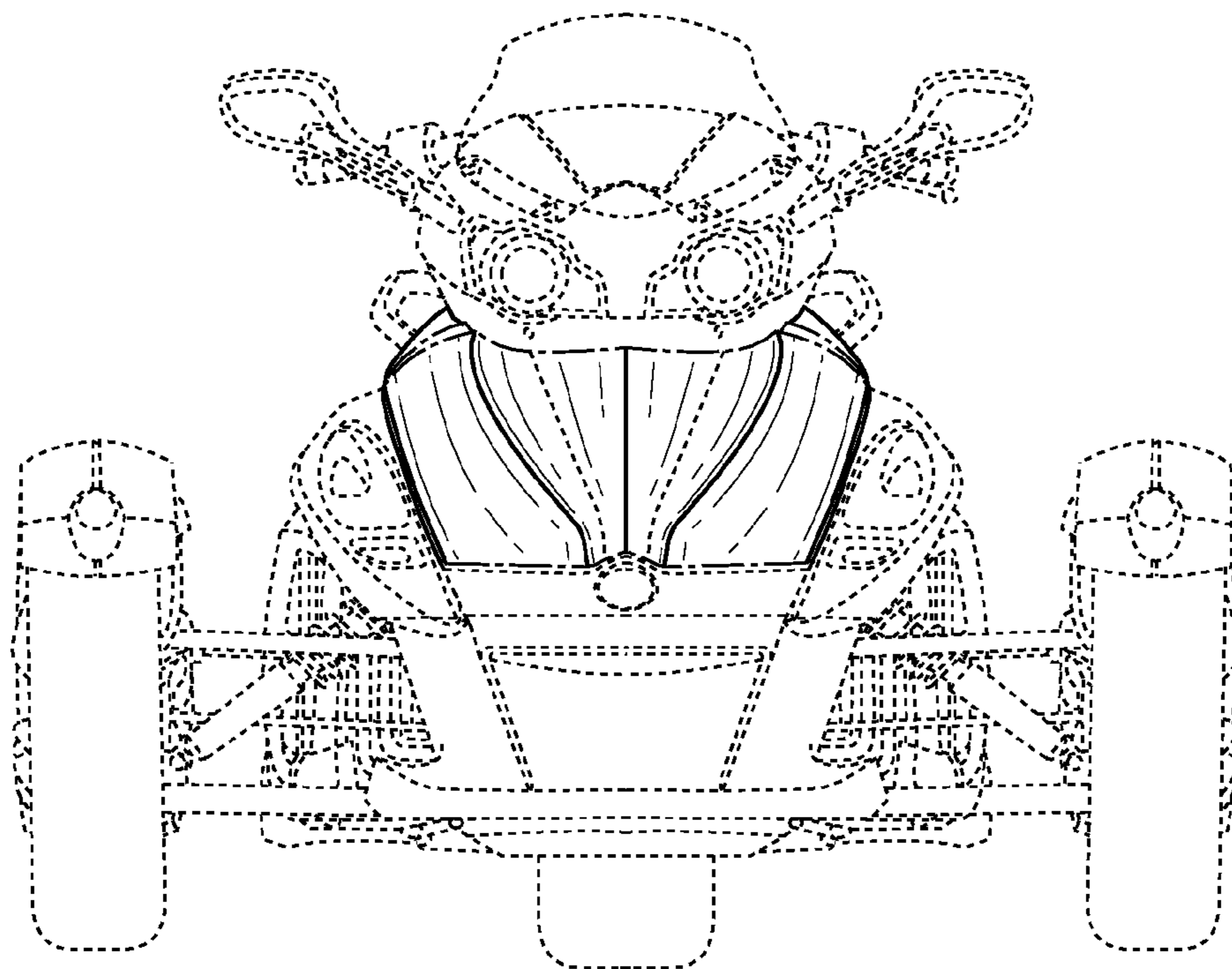

FIG. 7

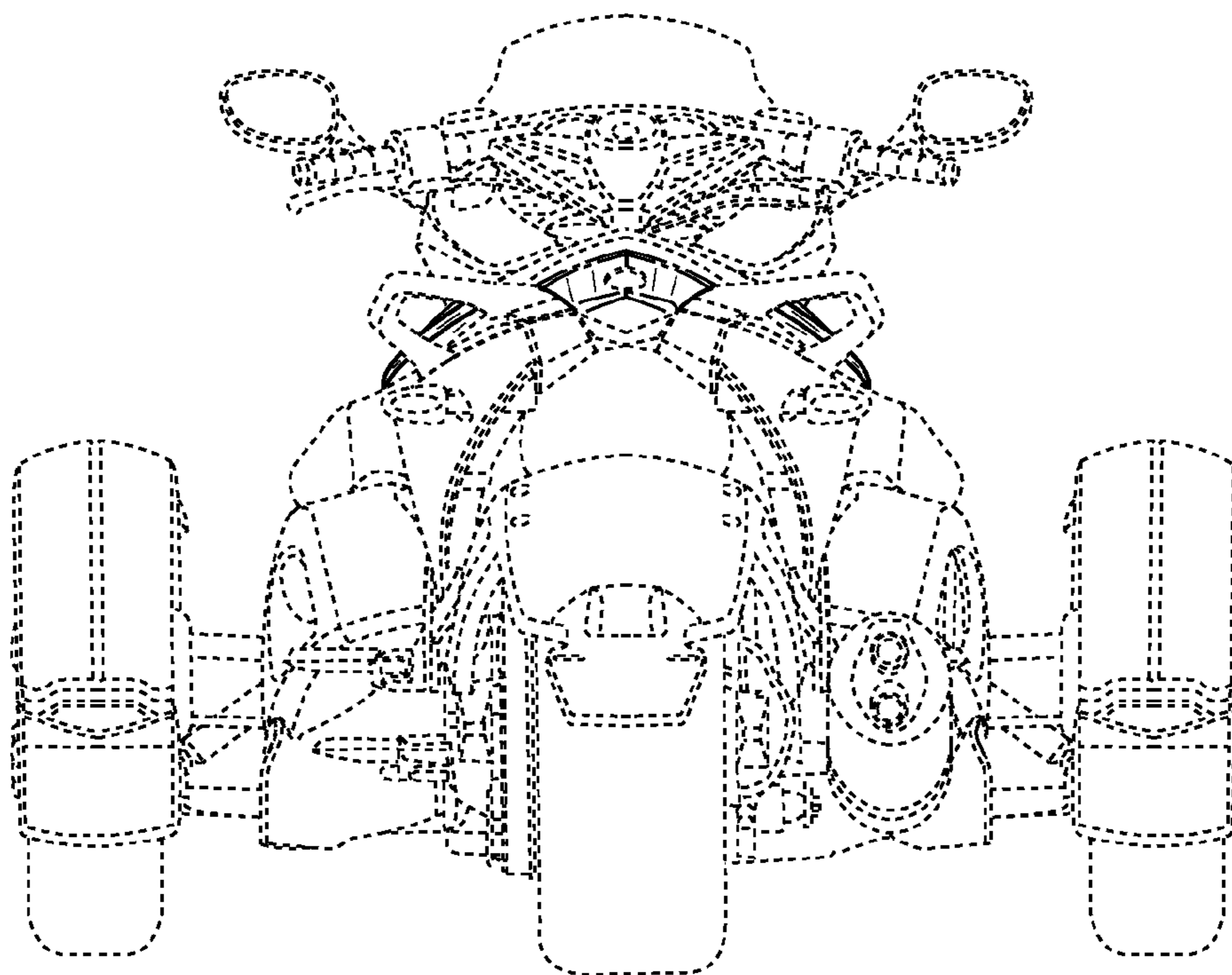

FIG. 8

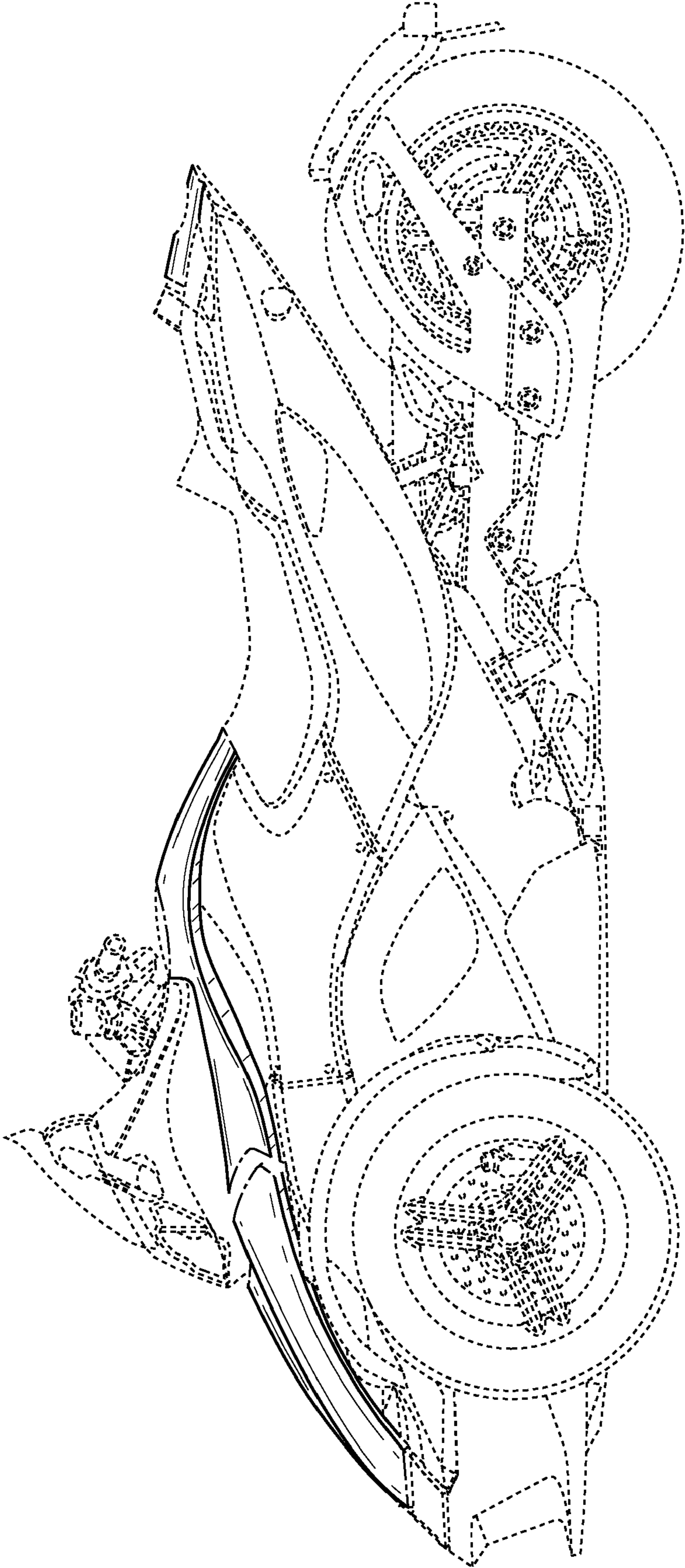

FIG. 9

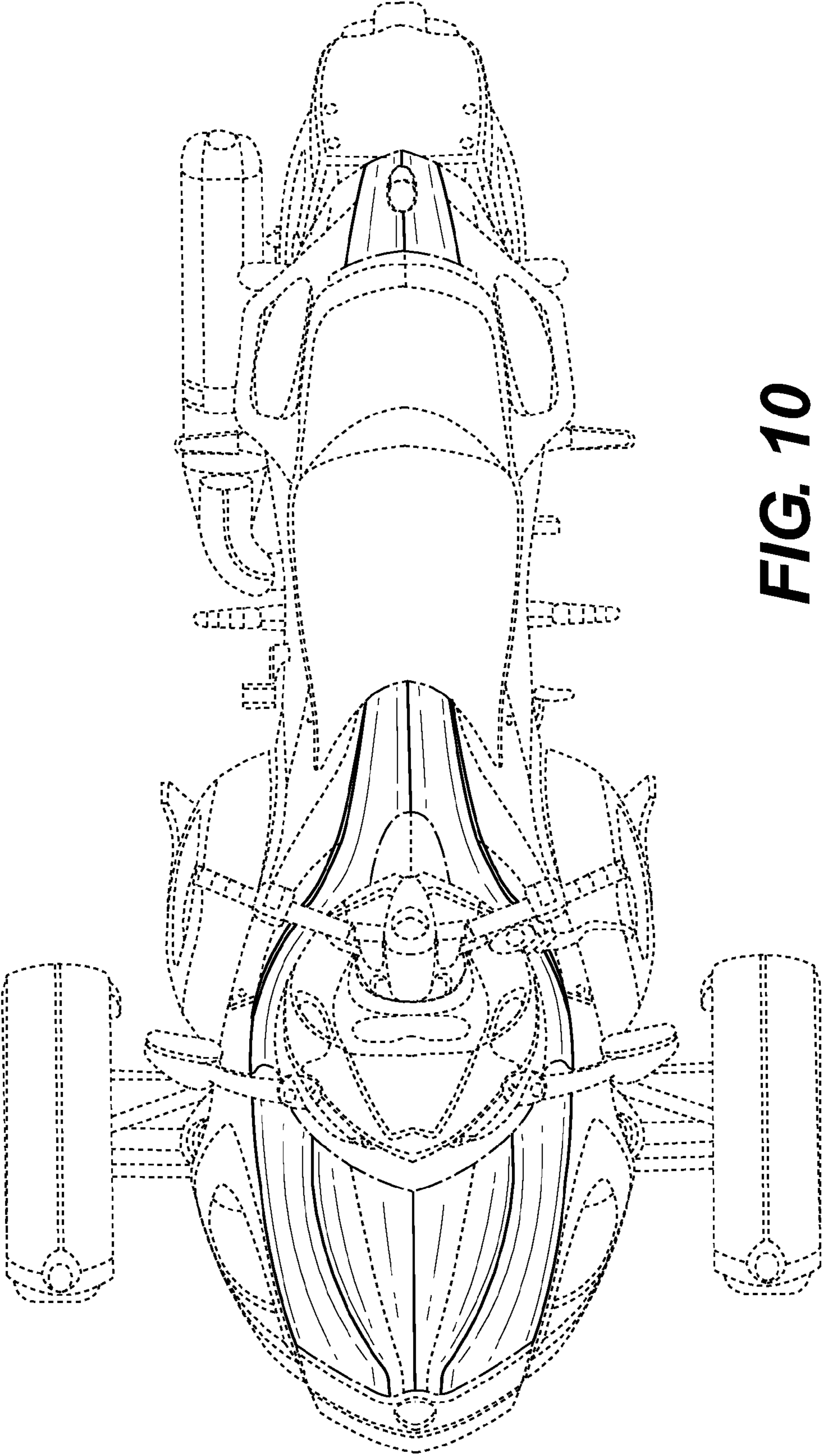

FIG. 10

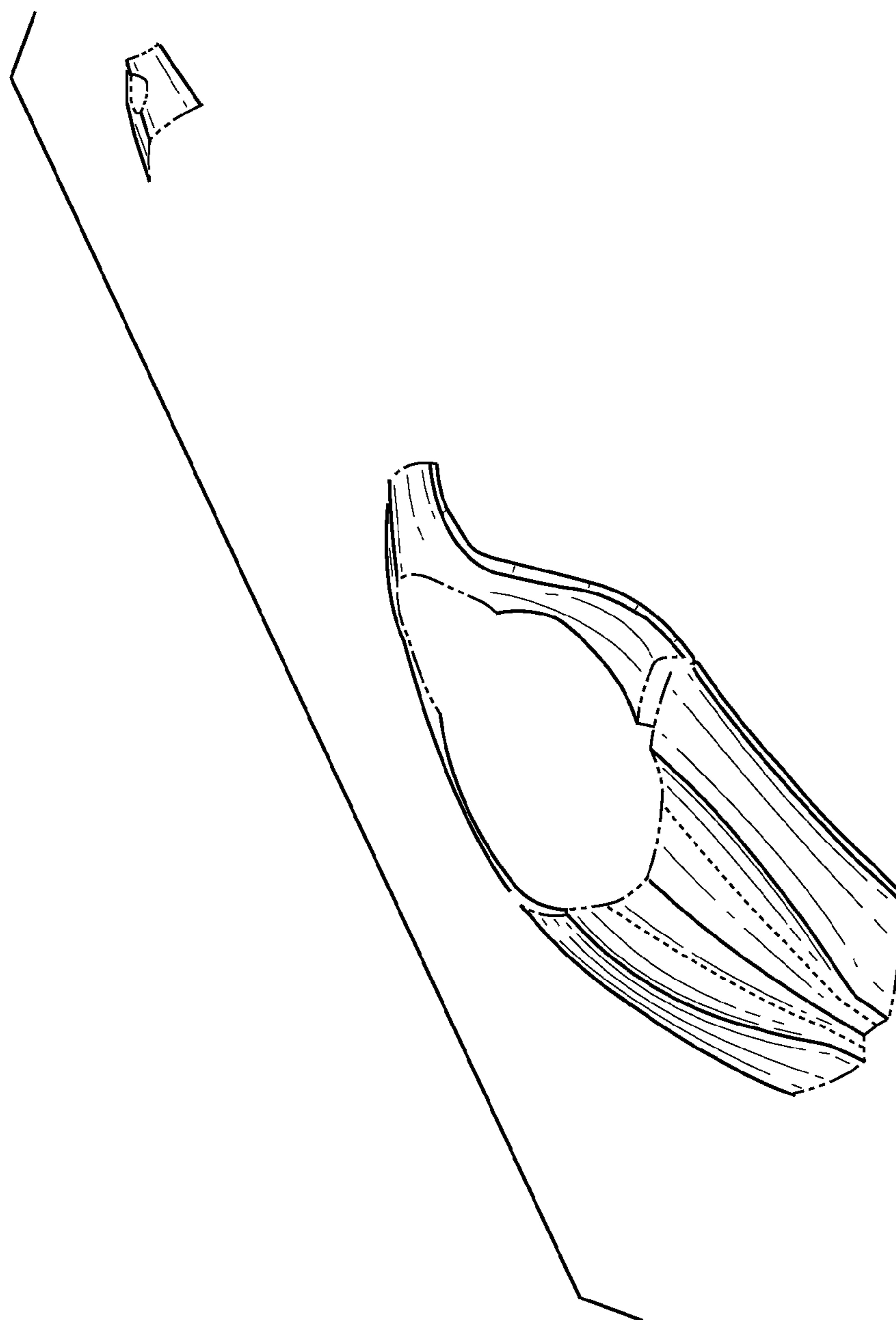

FIG. 11

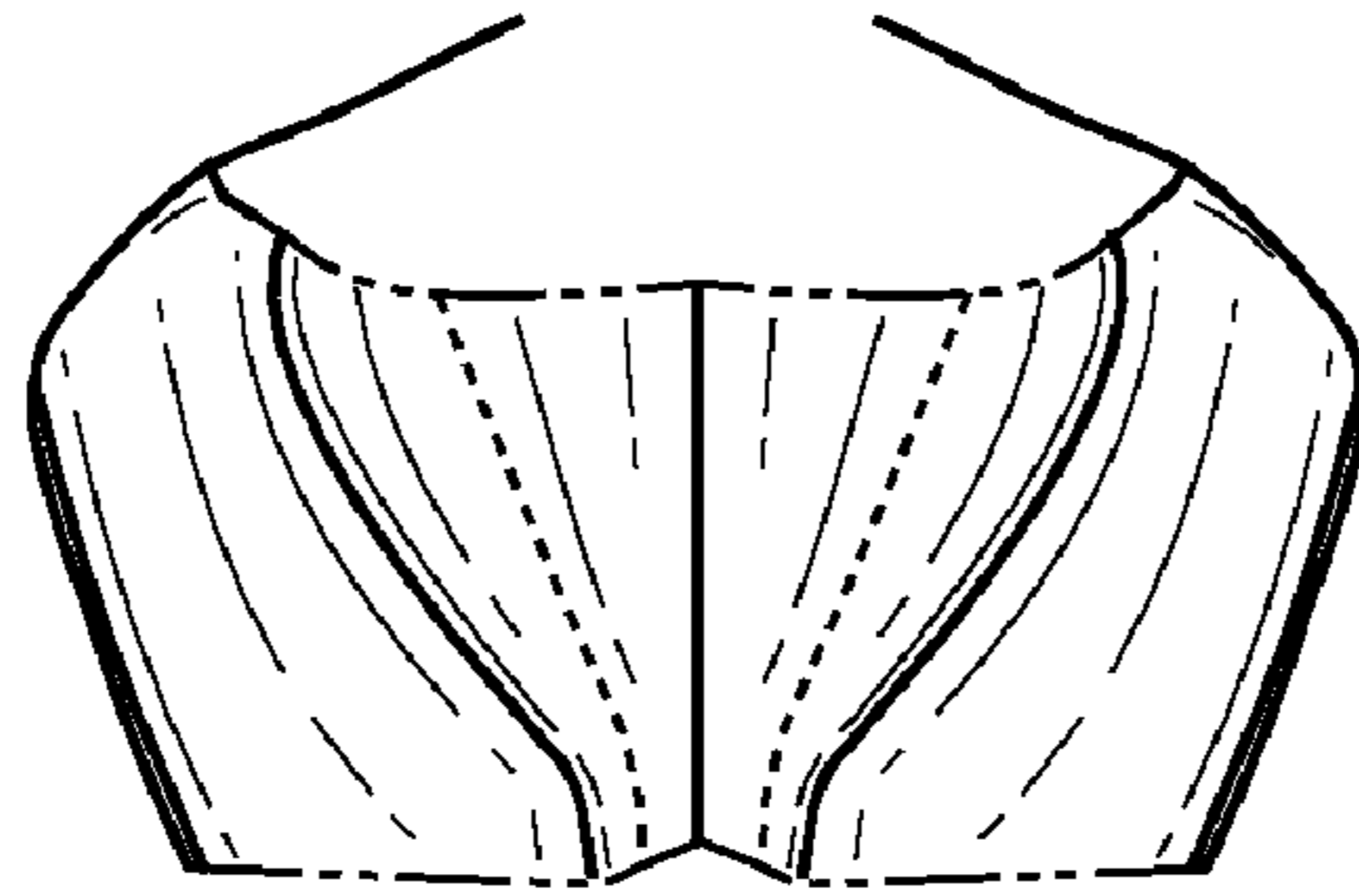

FIG. 12



FIG. 13

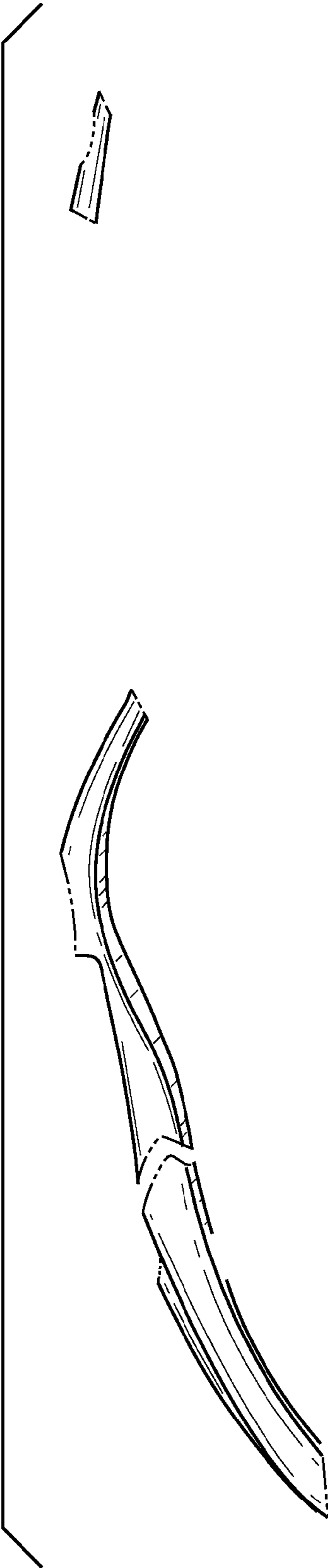

FIG. 14

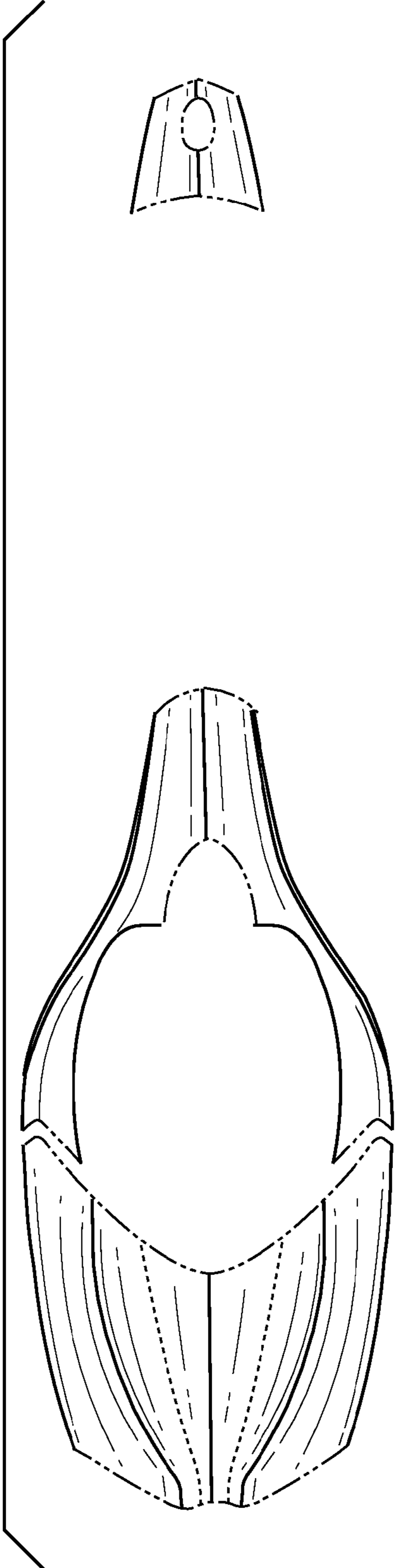

FIG. 15