



US00D581319S

(12) **United States Design Patent**
Longpre et al.

(10) **Patent No.:** **US D581,319 S**

(45) **Date of Patent:** **** *Nov. 25, 2008**

(54) **VEHICLE SIDE BODY PANEL**

(75) Inventors: **Guillaume Longpre**, Granby (CA);
Denys Lapointe, St-Bruno (CA);
Martin Portelance, Sherbrooke (CA);
Etienne Guay, Orford (CA); **Nicolas Deluy**, Sherbrooke (CA)

(73) Assignee: **Bombardier Recreational Products Inc.**, ValCourt (CA)

(**) Term: **14 Years**

(21) Appl. No.: **29/282,144**

(22) Filed: **Jul. 12, 2007**

Related U.S. Application Data

(63) Continuation-in-part of application No. 29/279,940, filed on May 11, 2007.

(51) **LOC (8) Cl.** **12-11**

(52) **U.S. Cl.** **D12/107; D12/184**

(58) **Field of Classification Search** D12/3,
D12/86, 87, 107, 110, 126, 184-186, 85;
280/304.3, 304.4, 152.1-152.3, 160, 160.1,
280/847-852, 770, 202, 282, 288.1-288.4;
296/77.1, 78.1, 180.1, 192, 193.01, 193.03-193.05;
180/219, 225, 220, 229, 223, 233, 311, 312,
180/16, 210-217

See application file for complete search history.

(56) **References Cited**

U.S. PATENT DOCUMENTS

4,423,795 A * 1/1984 Winchell et al. 180/215

(Continued)

FOREIGN PATENT DOCUMENTS

FR 025060 2/2003

OTHER PUBLICATIONS

Fig. 18 of U.S. Appl. No. 29/156,028, now U.S. Design No. D485,788 (figure cancelled during prosecution).

Primary Examiner—Cathron C Brooks

Assistant Examiner—Linda Brooks

(74) *Attorney, Agent, or Firm*—Osler, Hoskin & Harcourt LLP

(57) **CLAIM**

The ornamental design for a vehicle side body panel, as shown and described.

DESCRIPTION

FIG. 1 is a perspective view from the rear and left side of a vehicle side body panel

FIG. 2 is a left side elevational view thereof;

FIG. 3 is a top plan view thereof;

FIG. 4 is a bottom plan view thereof;

FIG. 5 is a front elevational view thereof; FIG. 6 is a rear elevational view thereof;

FIG. 7 is a perspective view from the rear and right side of a vehicle side body panel according to a second embodiment of our design;

FIG. 8 is a right side elevational view thereof;

FIG. 9 is a top plan view thereof;

FIG. 10 is a bottom plan view thereof;

FIG. 11 is a front elevational view thereof;

FIG. 12 is a rear elevational view thereof;

FIG. 13 is a perspective view from the rear and left side of a vehicle side body panel according to a third embodiment of our design;

FIG. 14 is a left side elevational view thereof;

FIG. 15 is a top plan view thereof;

FIG. 16 is a bottom plan view thereof;

FIG. 17 is a front elevational view thereof; and,

FIG. 18 is a rear elevational view thereof.

Throughout the Figures, broken lines showing structure or environment are for illustrative purposes only and form no part of the claimed design. Portions of the article not shown in the drawings, and portions of the article shown in the drawings but not shaded, form no part of the claimed design.

1 Claim, 15 Drawing Sheets

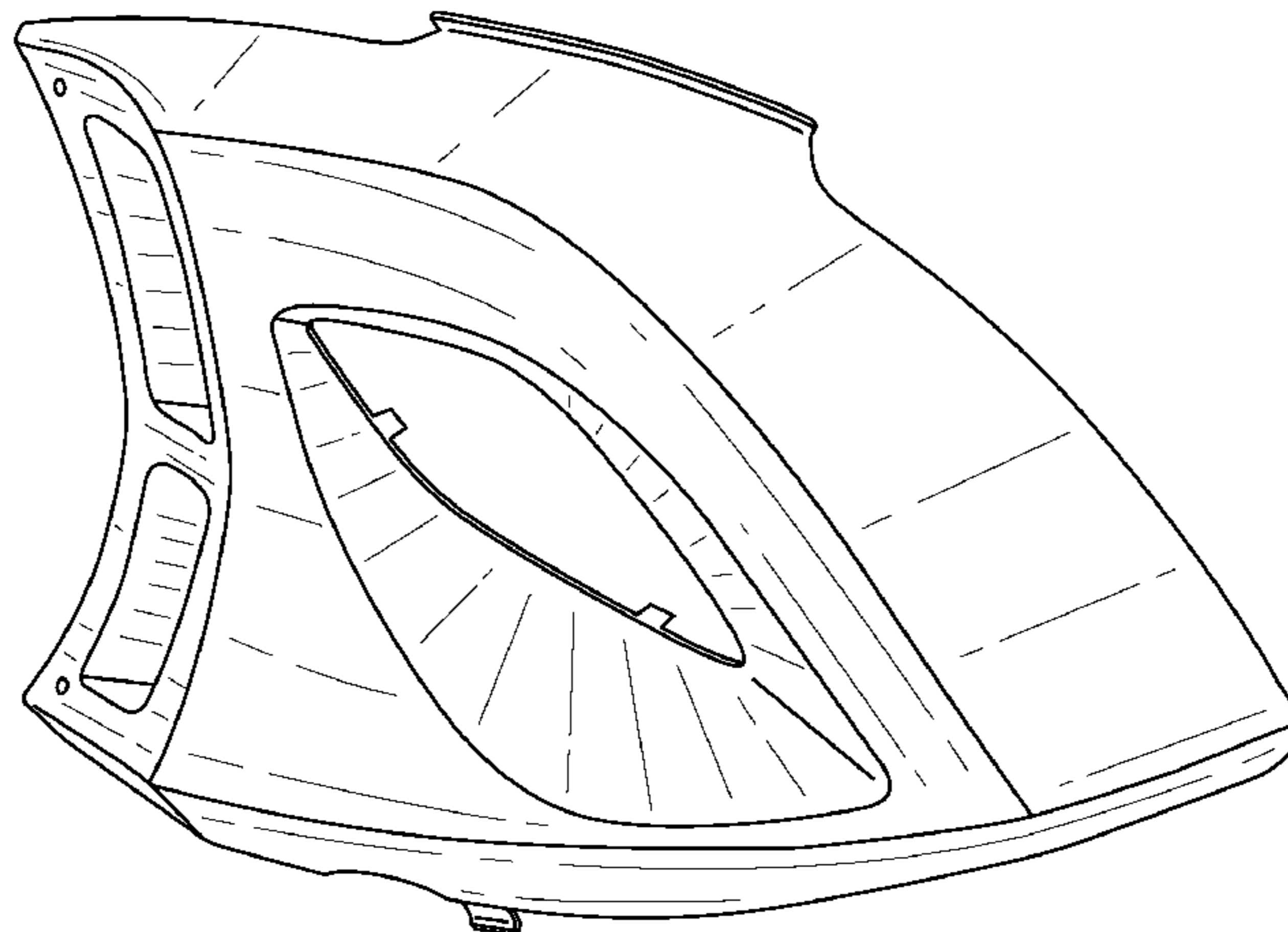

US D581,319 S

Page 2

U.S. PATENT DOCUMENTS									
D292,565	S *	11/1987	Badsey	D12/85	2003/0221890	A1	12/2003	Fecteau et al.	
6,446,744	B2	9/2002	Wubbolts et al.		2003/0221891	A1	12/2003	Fecteau et al.	
6,604,594	B2	8/2003	Wubbolts et al.		2004/0032120	A1	2/2004	Vaisanen et al.	
6,655,487	B2	12/2003	Mallette et al.		2004/0035623	A1	2/2004	Fecteau et al.	
D485,788	S	1/2004	Guay et al.		2004/0035624	A1	2/2004	Fecteau et al.	
6,866,110	B2	3/2005	Mallette et al.		2004/0035625	A1	2/2004	Talbot et al.	
D506,961	S *	7/2005	Sugimoto	D12/186	2004/0035626	A1	2/2004	Girouard et al.	
6,948,581	B2	9/2005	Fecteau et al.		2004/0129473	A1	7/2004	Talbot et al.	
7,097,207	B2 *	8/2006	Kudo et al.	280/848	2004/0129483	A1	7/2004	Girouard et al.	
D529,841	S *	10/2006	Vey	D12/110	2004/0140140	A1	7/2004	Guay et al.	
D547,242	S *	7/2007	Lambri et al.	D12/110	2005/0039967	A1	2/2005	Aube et al.	
D547,701	S *	7/2007	Vey	D12/110	2007/0075514	A1 *	4/2007	Saiki	280/124.103
2001/0040064	A1	11/2001	Girouard et al.		2007/0256882	A1 *	11/2007	Bedard et al.	180/312
2002/0129984	A1	9/2002	Wubbolts et al.						

* cited by examiner

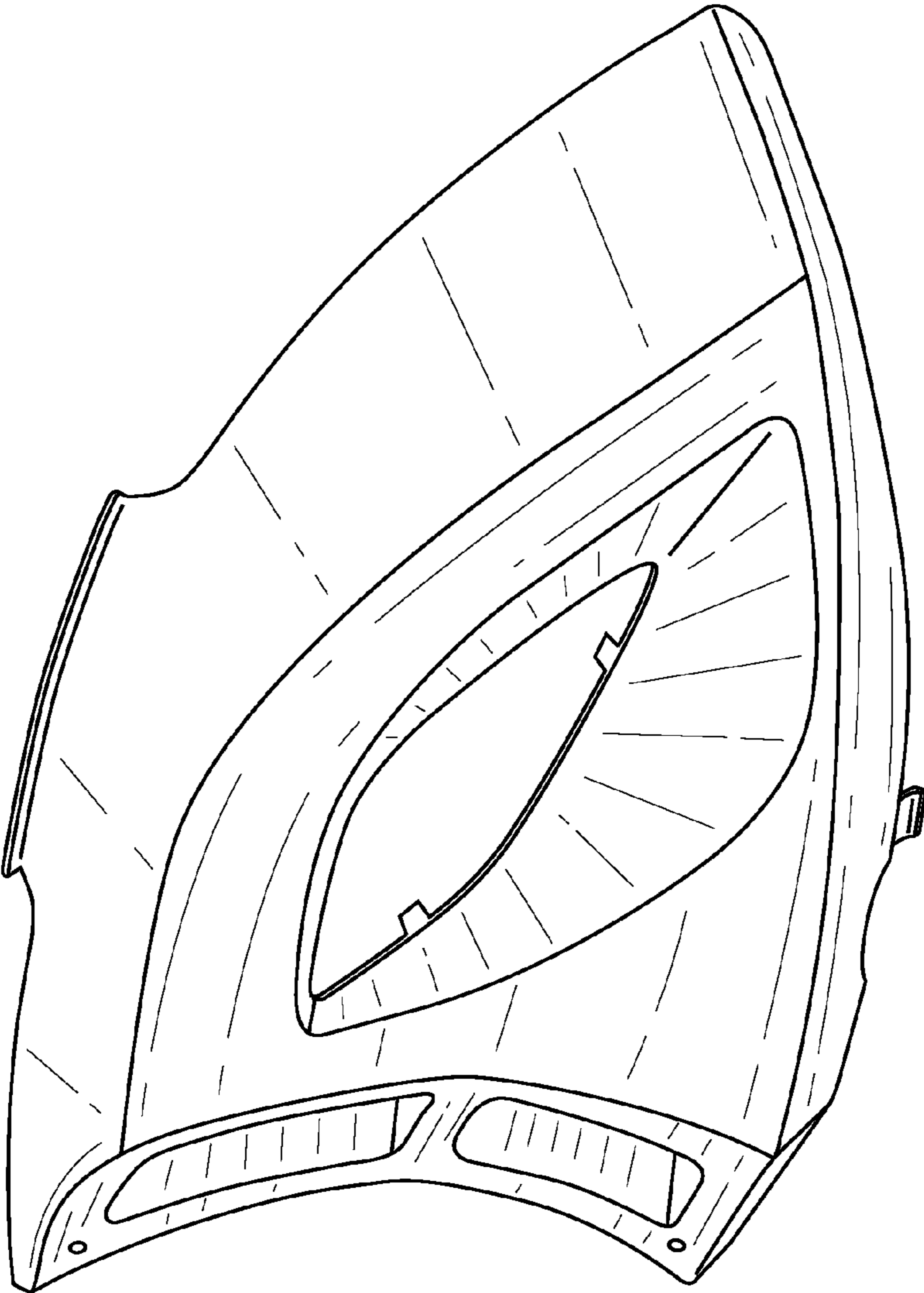

FIG. 1

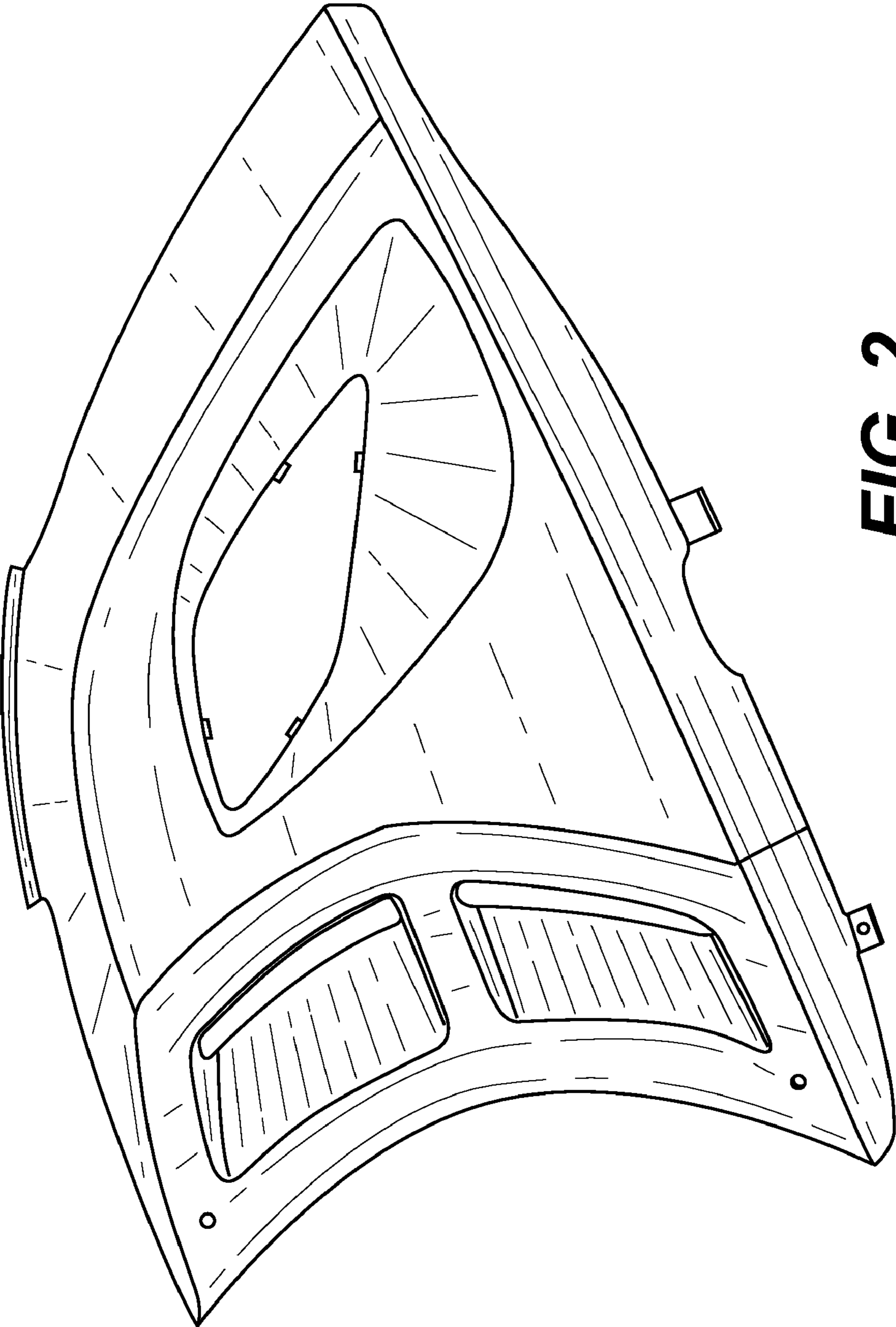

FIG. 2



FIG. 3

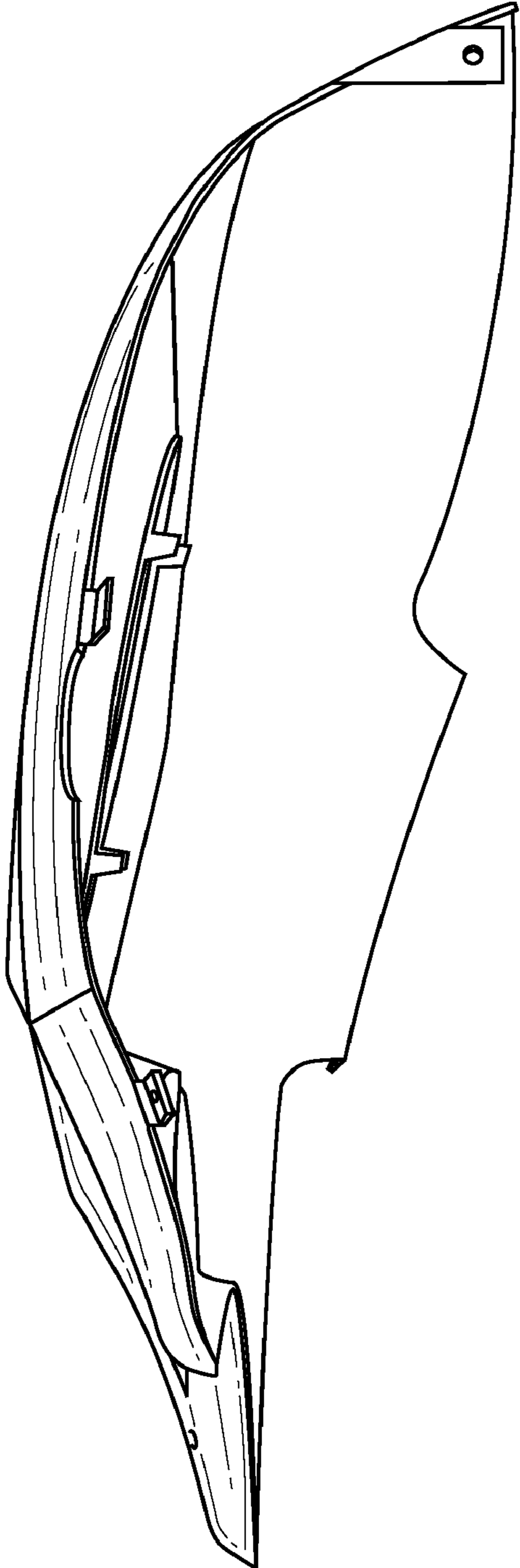

FIG. 4

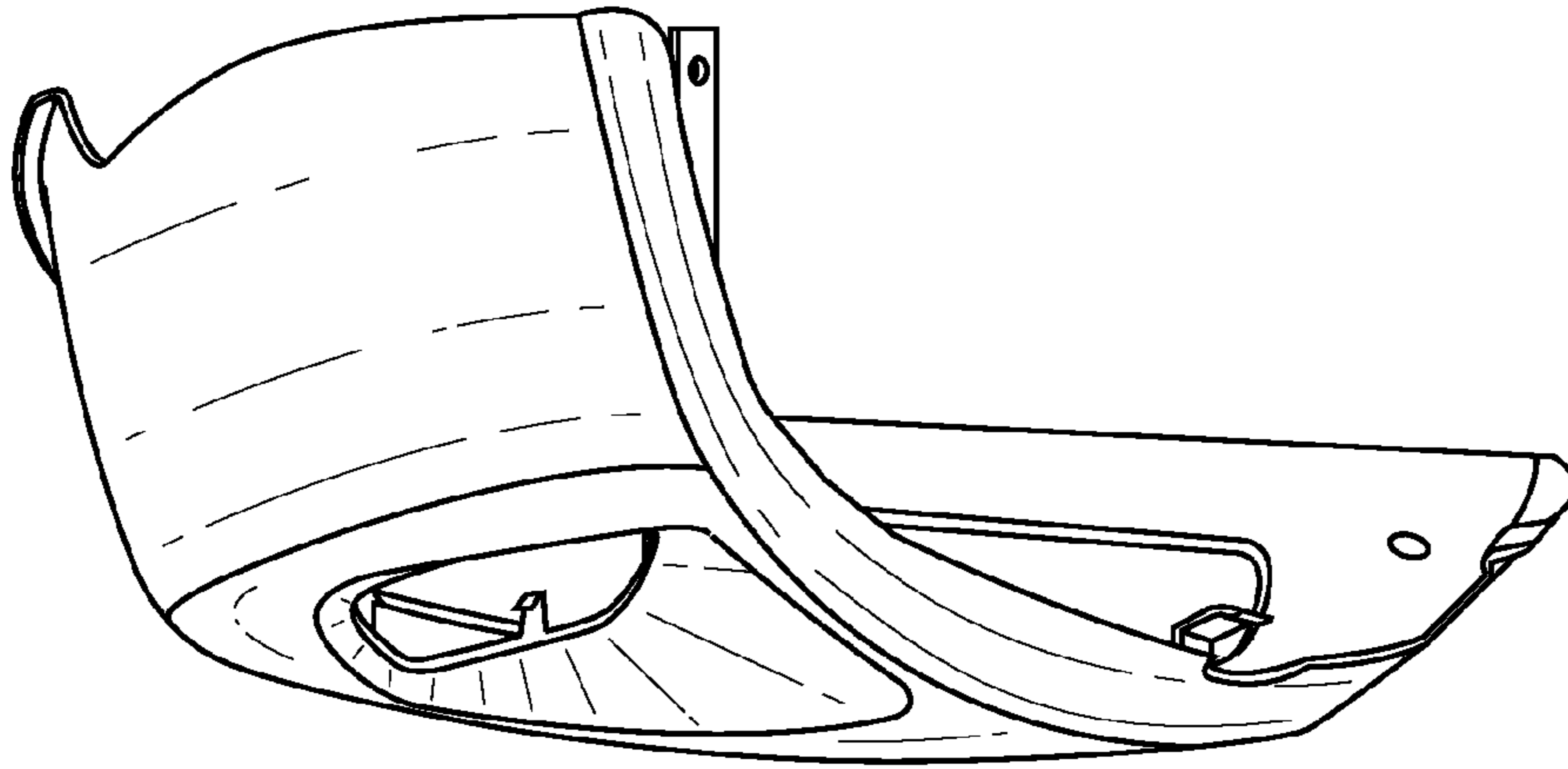

FIG. 5

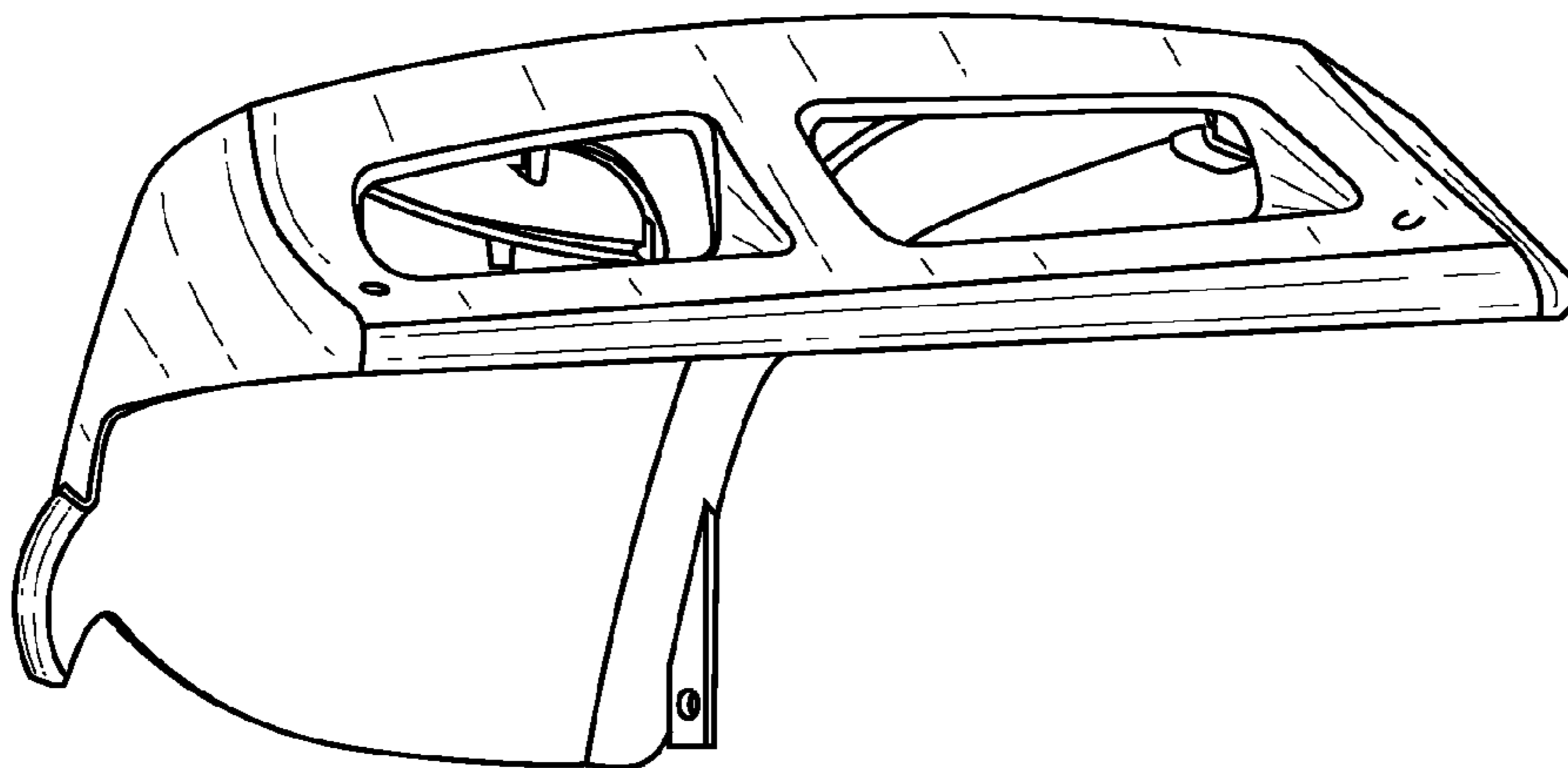

FIG. 6

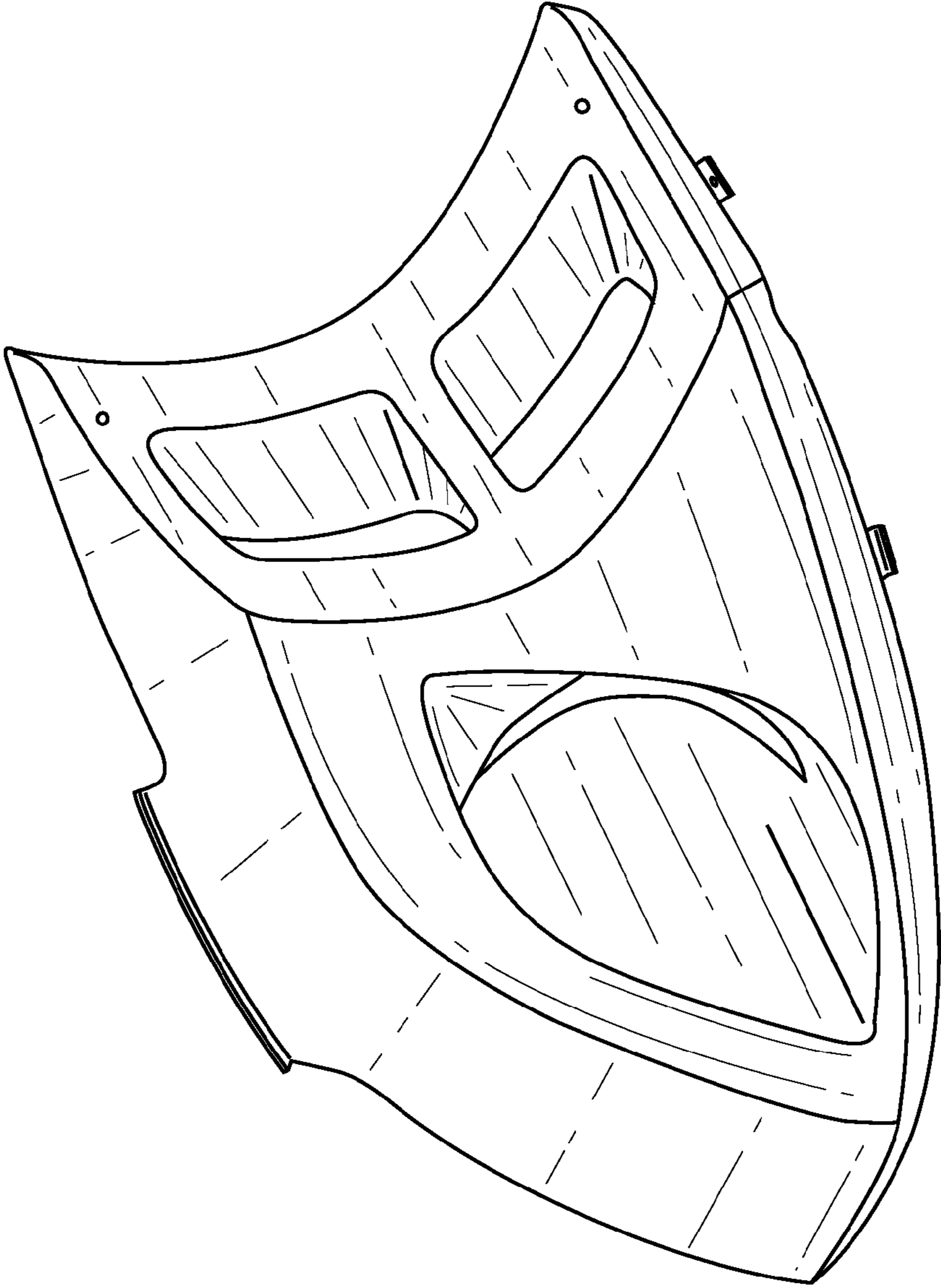

FIG. 7

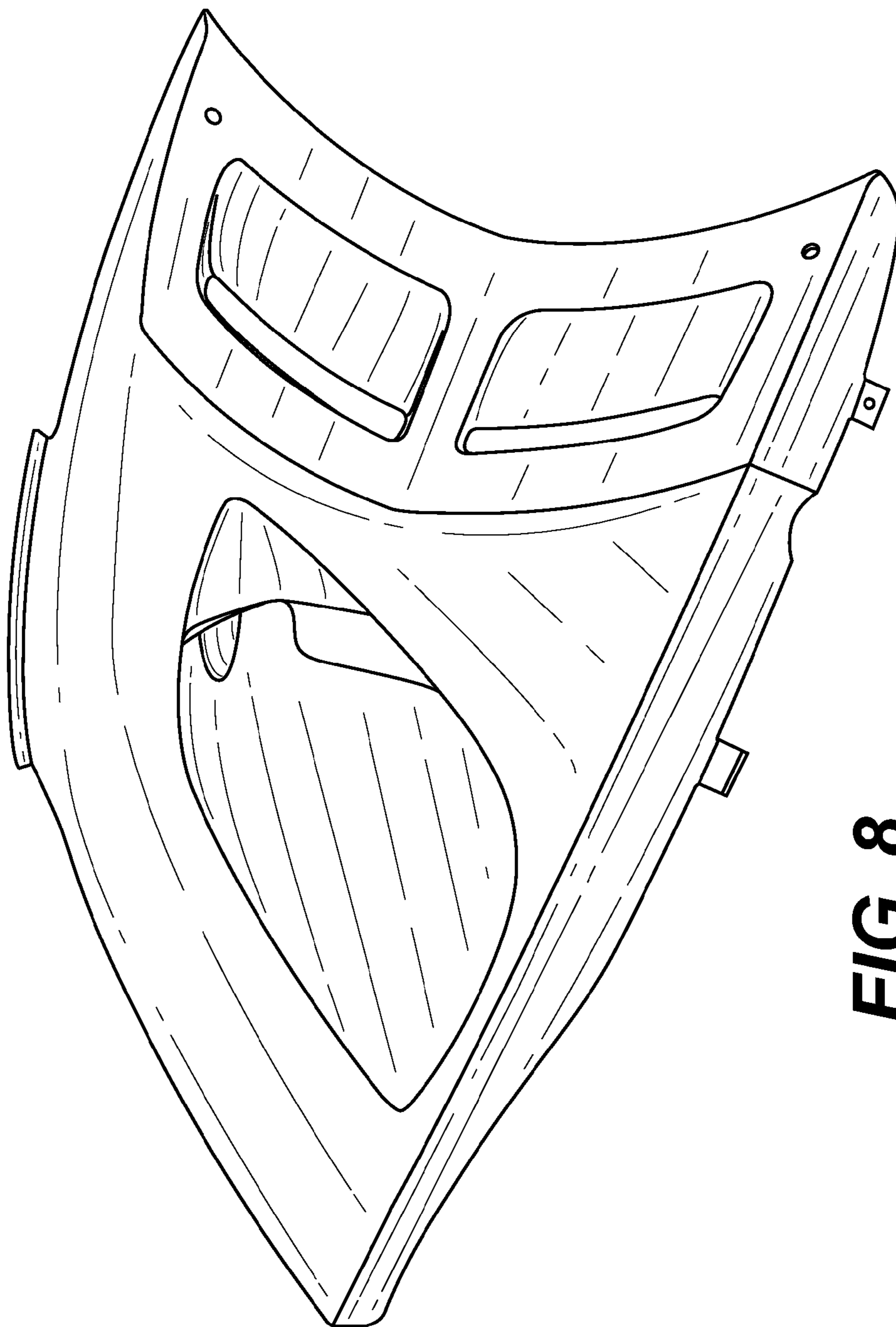

FIG. 8

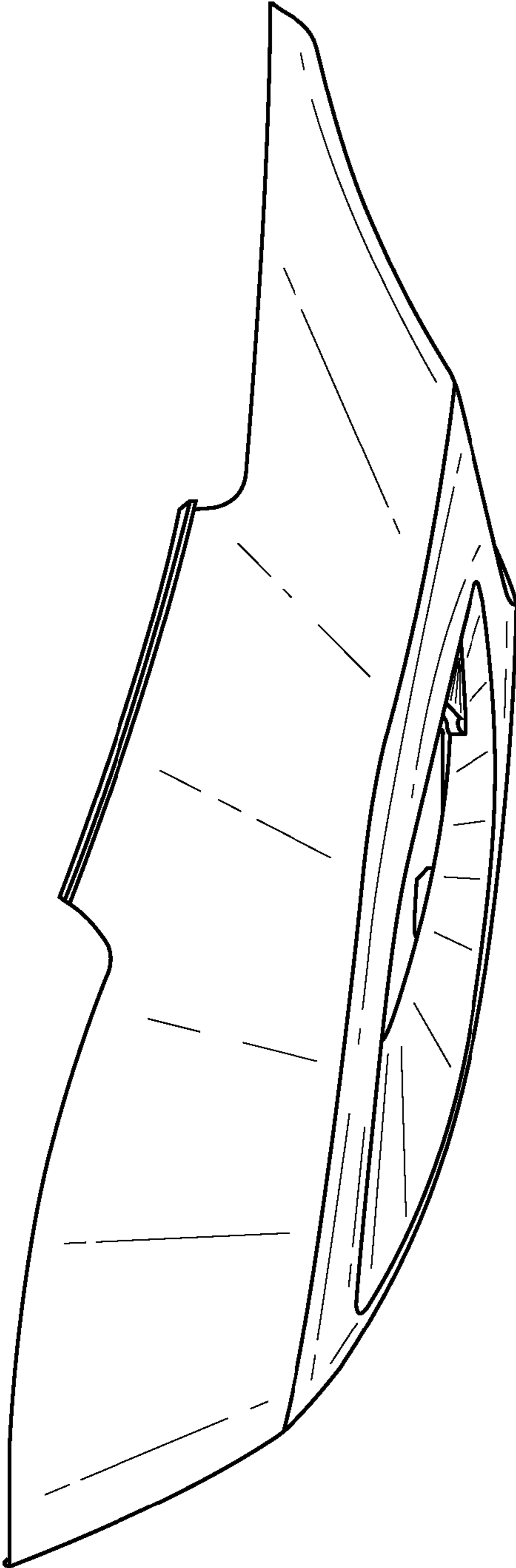

FIG. 9

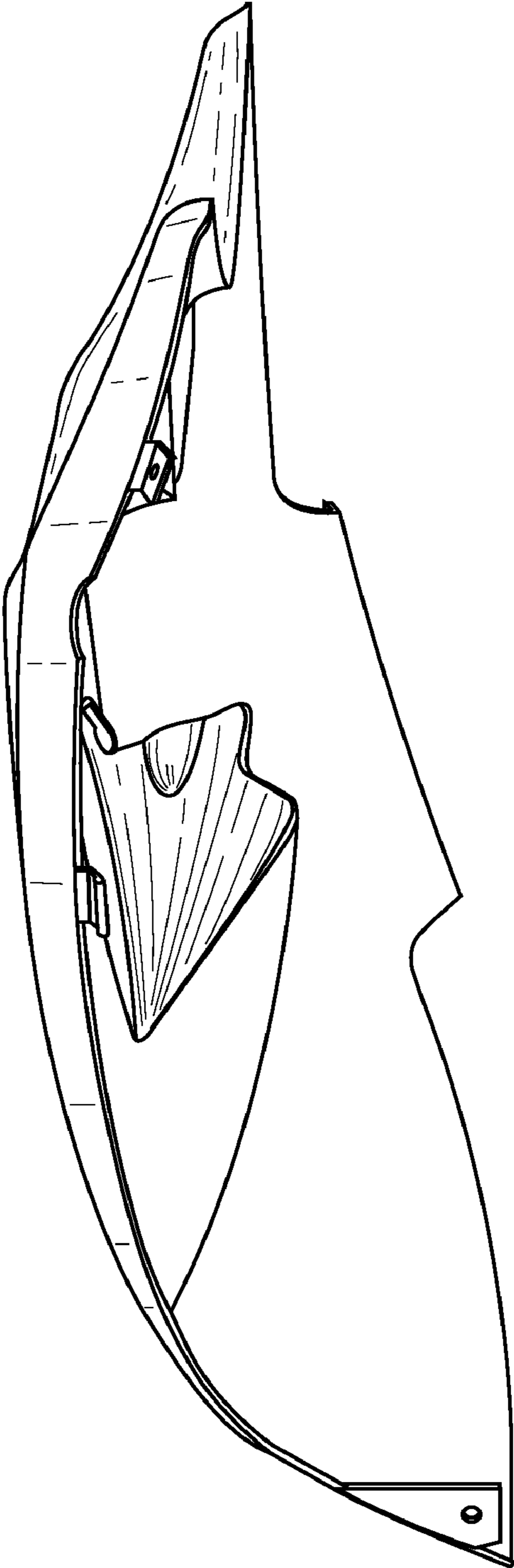

FIG. 10

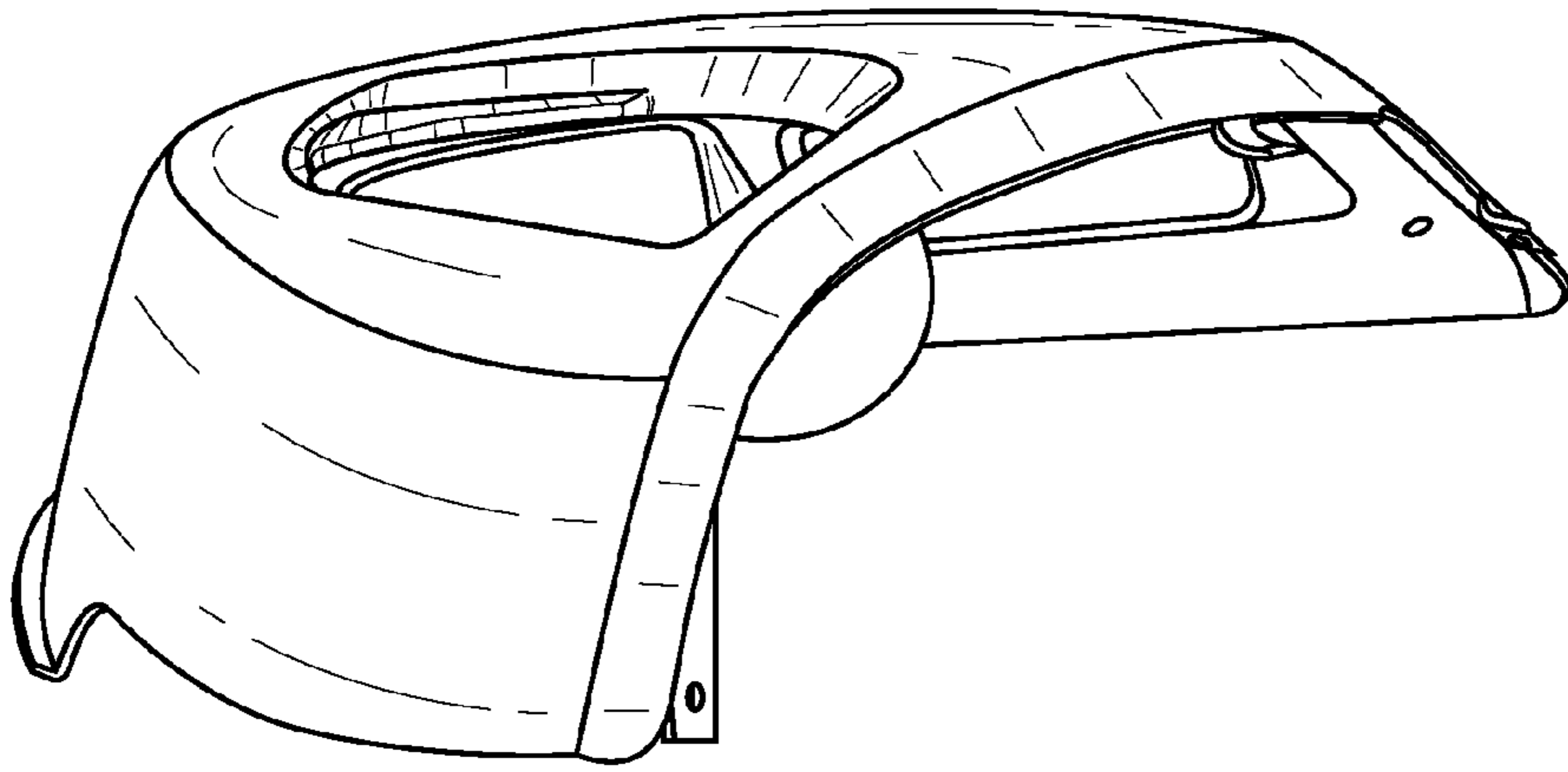

FIG. 12

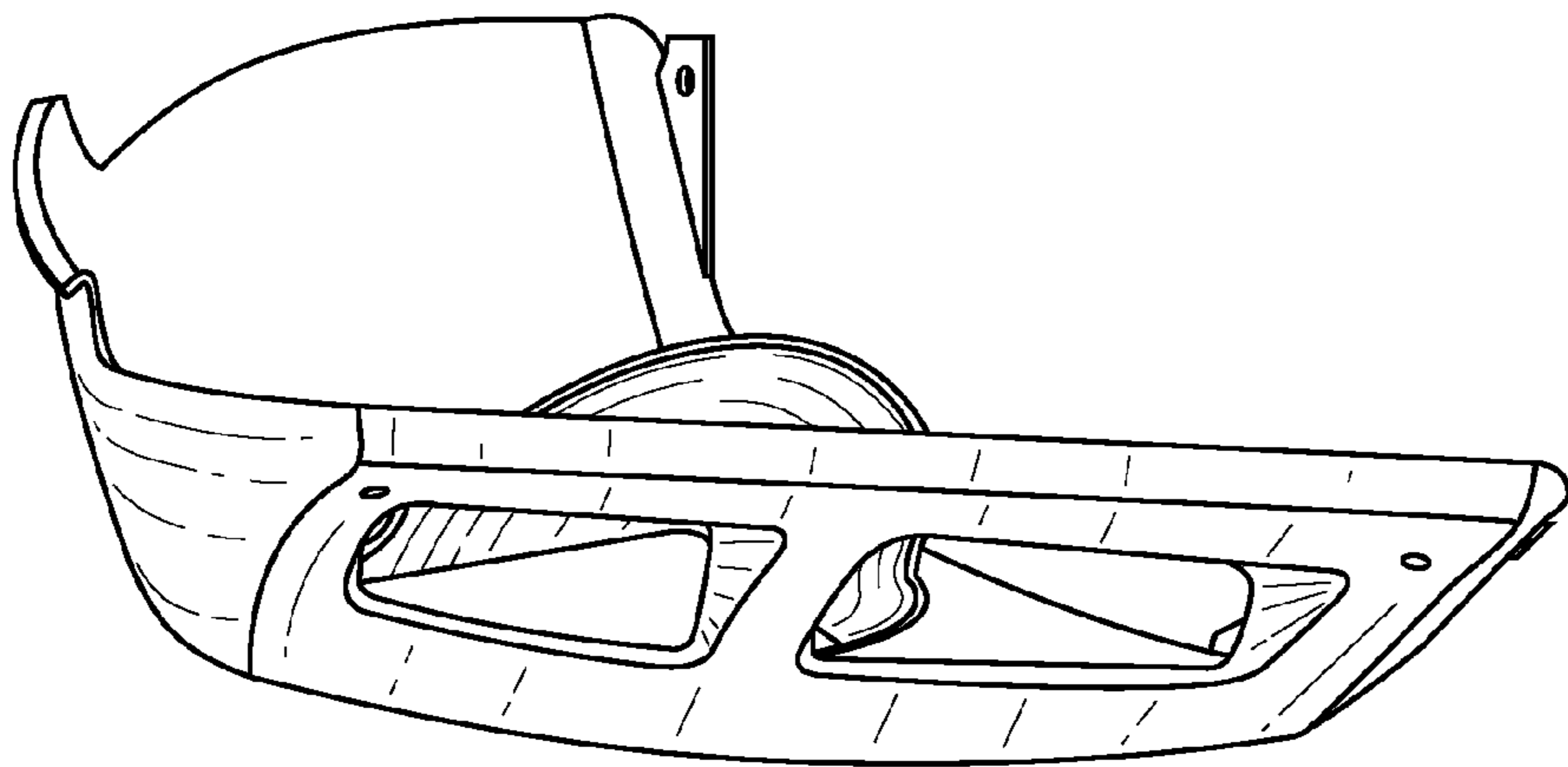

FIG. 11

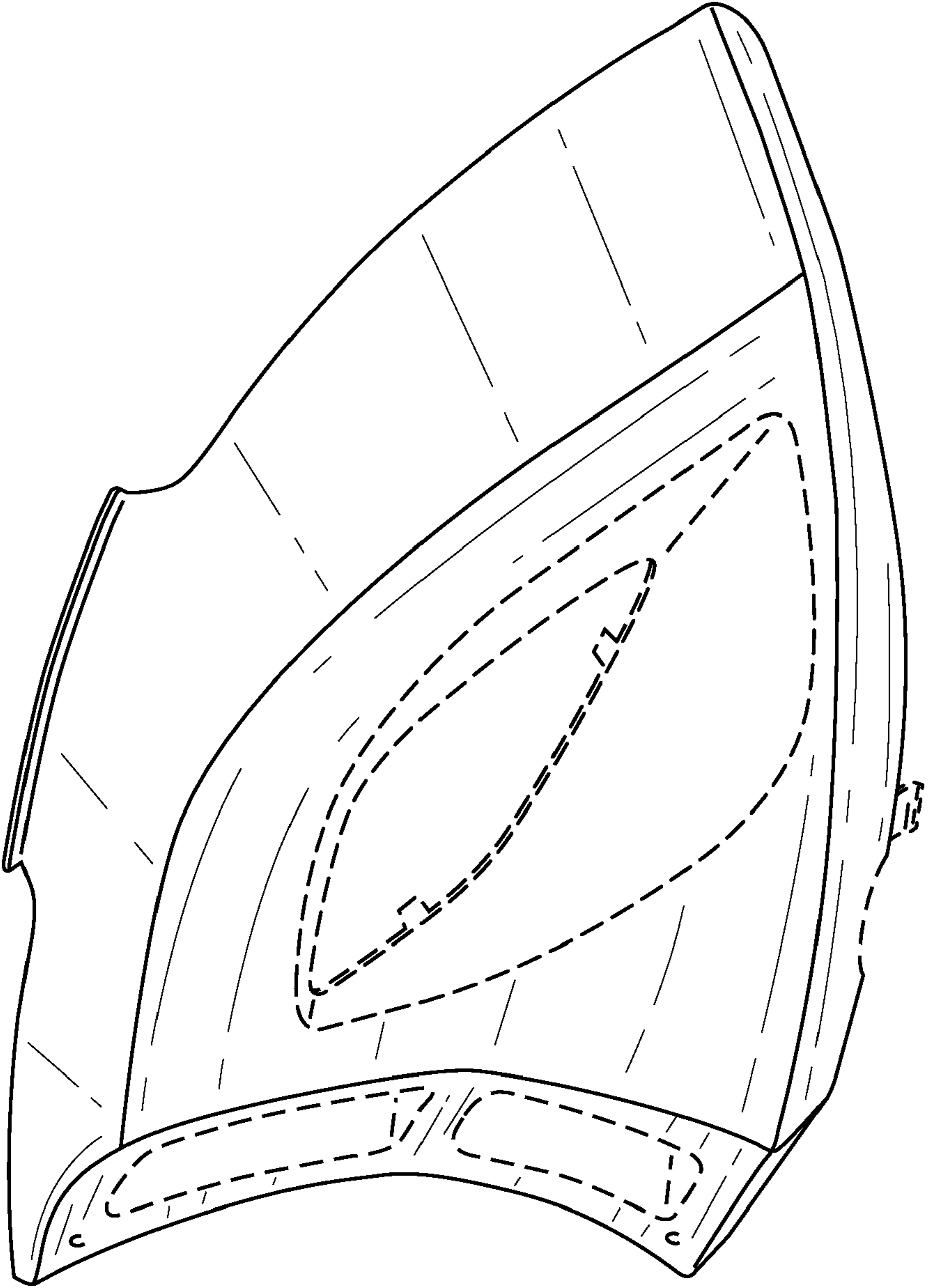

FIG. 13

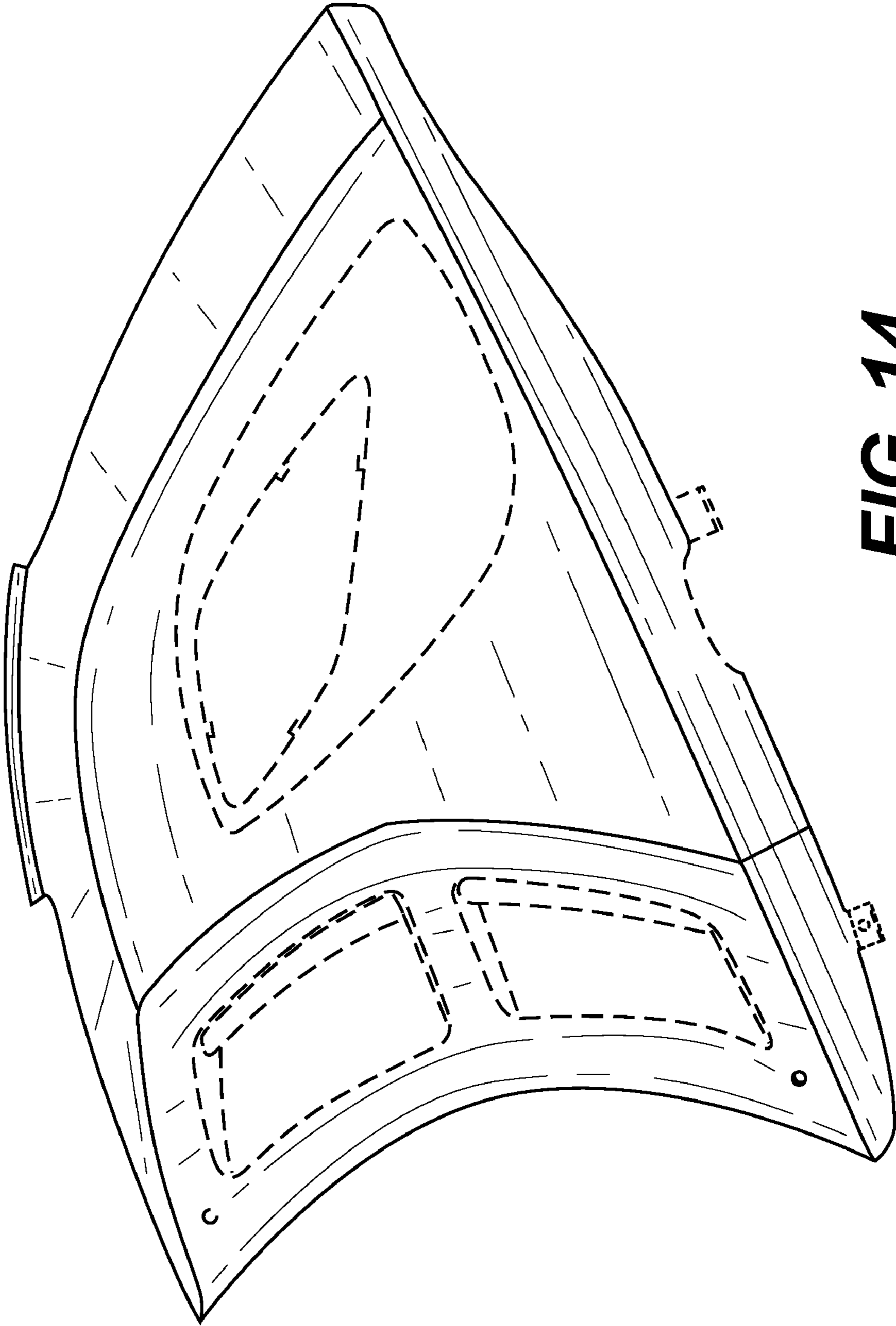

FIG. 14

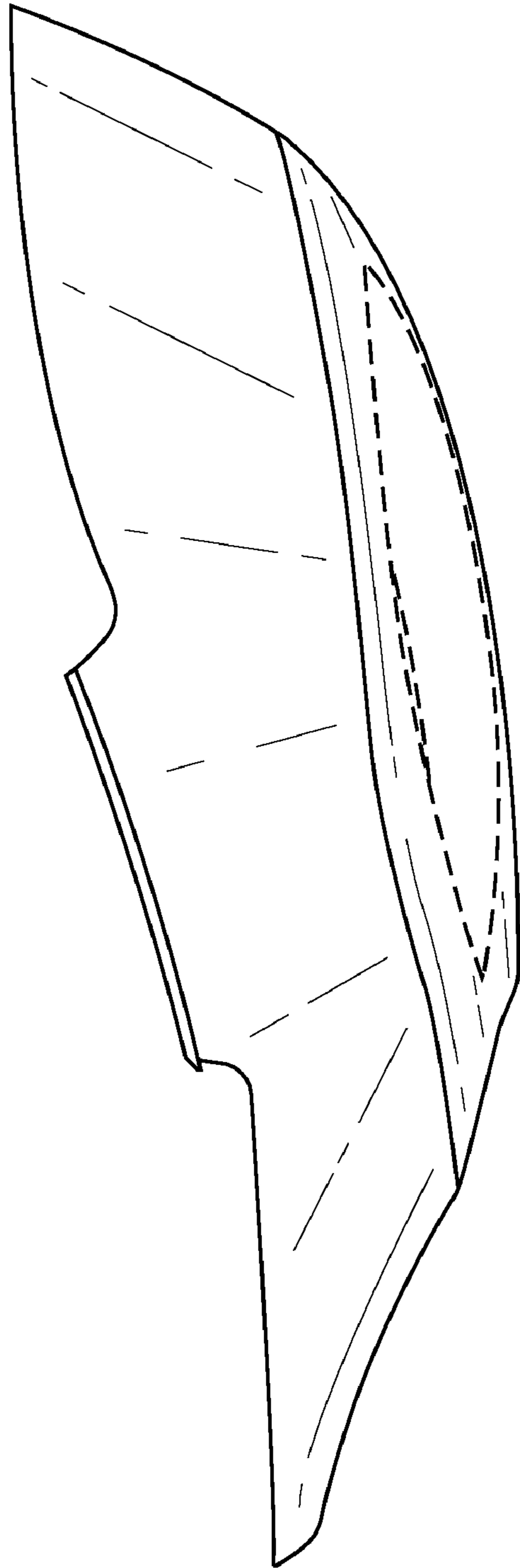

FIG. 15

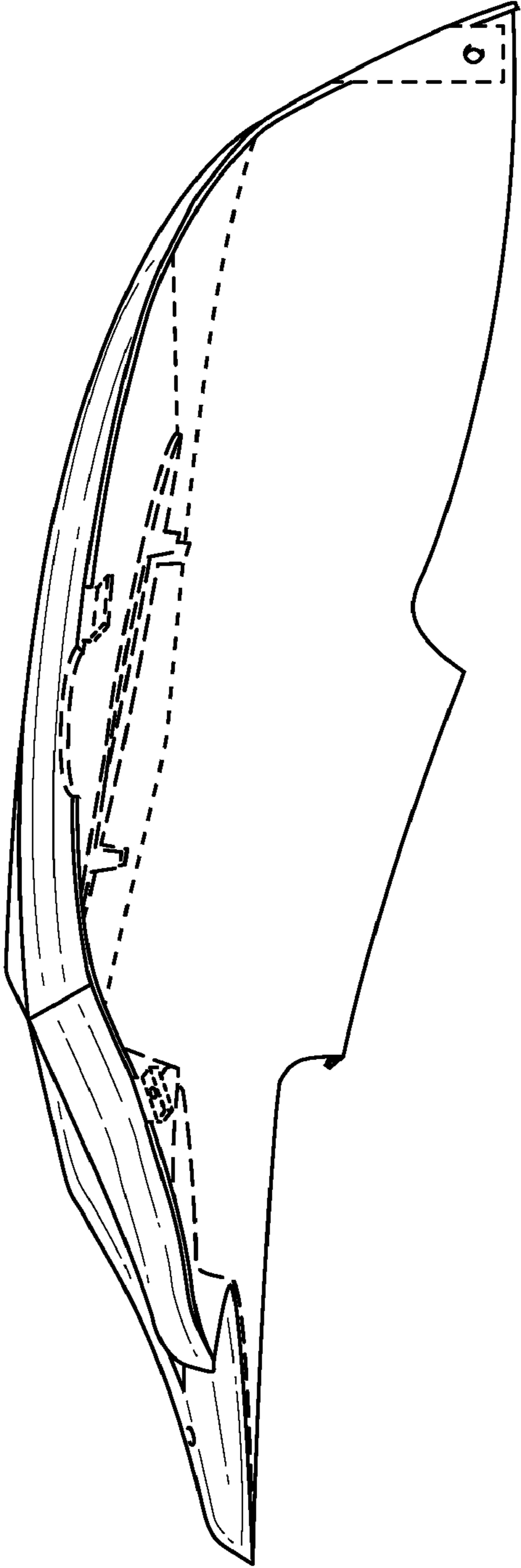

FIG. 16

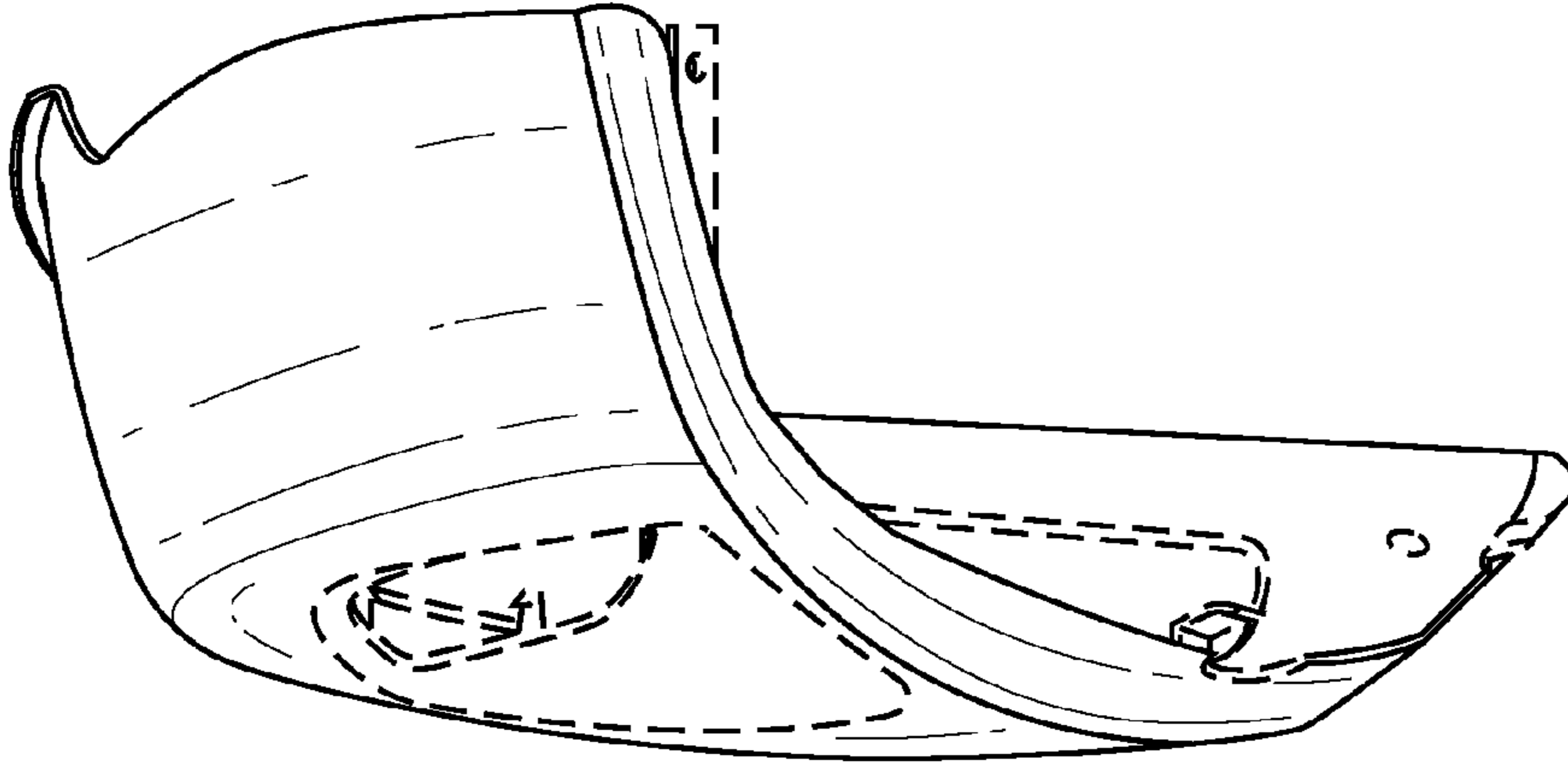

FIG. 17

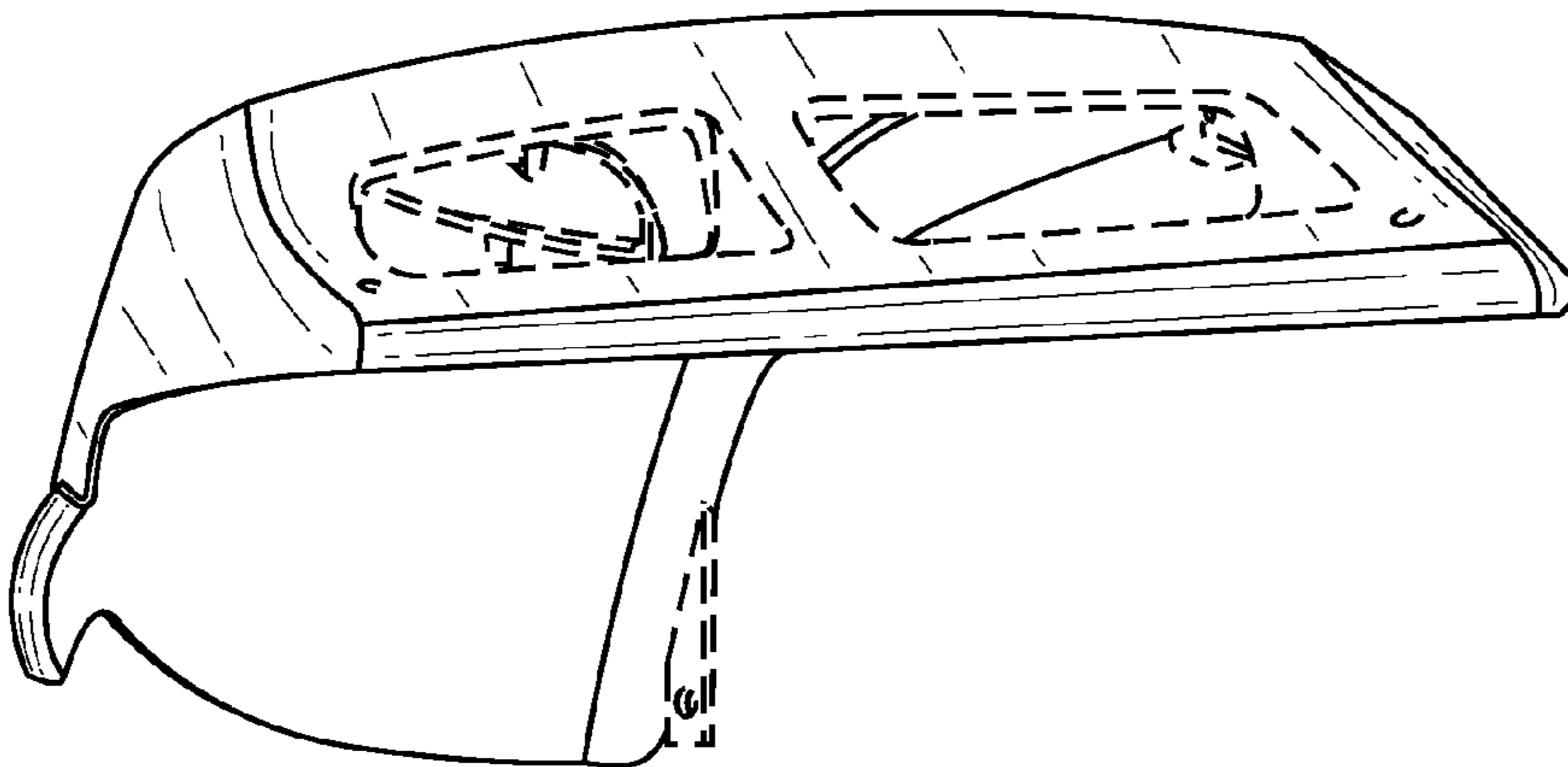

FIG. 18