



US00D581106S

(12) **United States Design Patent**
Prat-Pfister

(10) **Patent No.:** **US D581,106 S**

(45) **Date of Patent:** **** Nov. 18, 2008**

(54) **WASHING MACHINE FOR SHAVER**

(75) Inventor: **Gael Prat-Pfister**, Amersfoort (NL)

(73) Assignee: **Koninklijke Philips Electronics N.V.**,
Eindhoven (NL)

(**) Term: **14 Years**

(21) Appl. No.: **29/284,889**

(22) Filed: **Sep. 18, 2007**

(30) **Foreign Application Priority Data**

Mar. 26, 2007 (EM) 000695614

(51) **LOC (8) Cl.** **15-05**

(52) **U.S. Cl.** **D32/1**

(58) **Field of Classification Search** D32/1,
D32/25, 35; 30/537-538; 15/104.92; D28/44,
D28/73; 134/113, 135, 201; D13/108; D9/424
See application file for complete search history.

(56) **References Cited**

U.S. PATENT DOCUMENTS

D455,397 S * 4/2002 Weiner et al. D13/108
D488,439 S * 4/2004 Orthey D13/107
D506,437 S * 6/2005 Nishizawa D13/108
D512,962 S * 12/2005 Nishizawa D13/108
D513,341 S * 12/2005 Ullmann D28/44
D532,687 S * 11/2006 Elgebrant et al. D9/424
7,150,285 B2 * 12/2006 Saito et al. 134/100.1

D543,315 S * 5/2007 Hansen D28/44
D549,647 S * 8/2007 Nishizawa D13/108
2004/0194326 A1 * 10/2004 Kappes et al. 30/537
2006/0042103 A1 * 3/2006 Chasen 30/537
2006/0048802 A1 * 3/2006 Kappes et al. 134/184

OTHER PUBLICATIONS

http://www.consumer.philips.com/catalog/HQ/HQ9170_40_webImage370.jpg May 13, 2008.*

* cited by examiner

Primary Examiner—Louis S Zarfaz

Assistant Examiner—Kathleen M Sims

(57) **CLAIM**

The ornamental design for a washing machine for shaver, as shown and described.

DESCRIPTION

FIG. 1 is a perspective view of a washing machine for shaver showing my new design;

FIG. 2 is a front elevational view thereof;

FIG. 3 is a rear elevational view thereof;

FIG. 4 is a right side elevational view thereof;

FIG. 5 is a left side elevational view thereof;

FIG. 6 is a top plan view thereof; and,

FIG. 7 is a bottom plan view thereof.

1 Claim, 4 Drawing Sheets

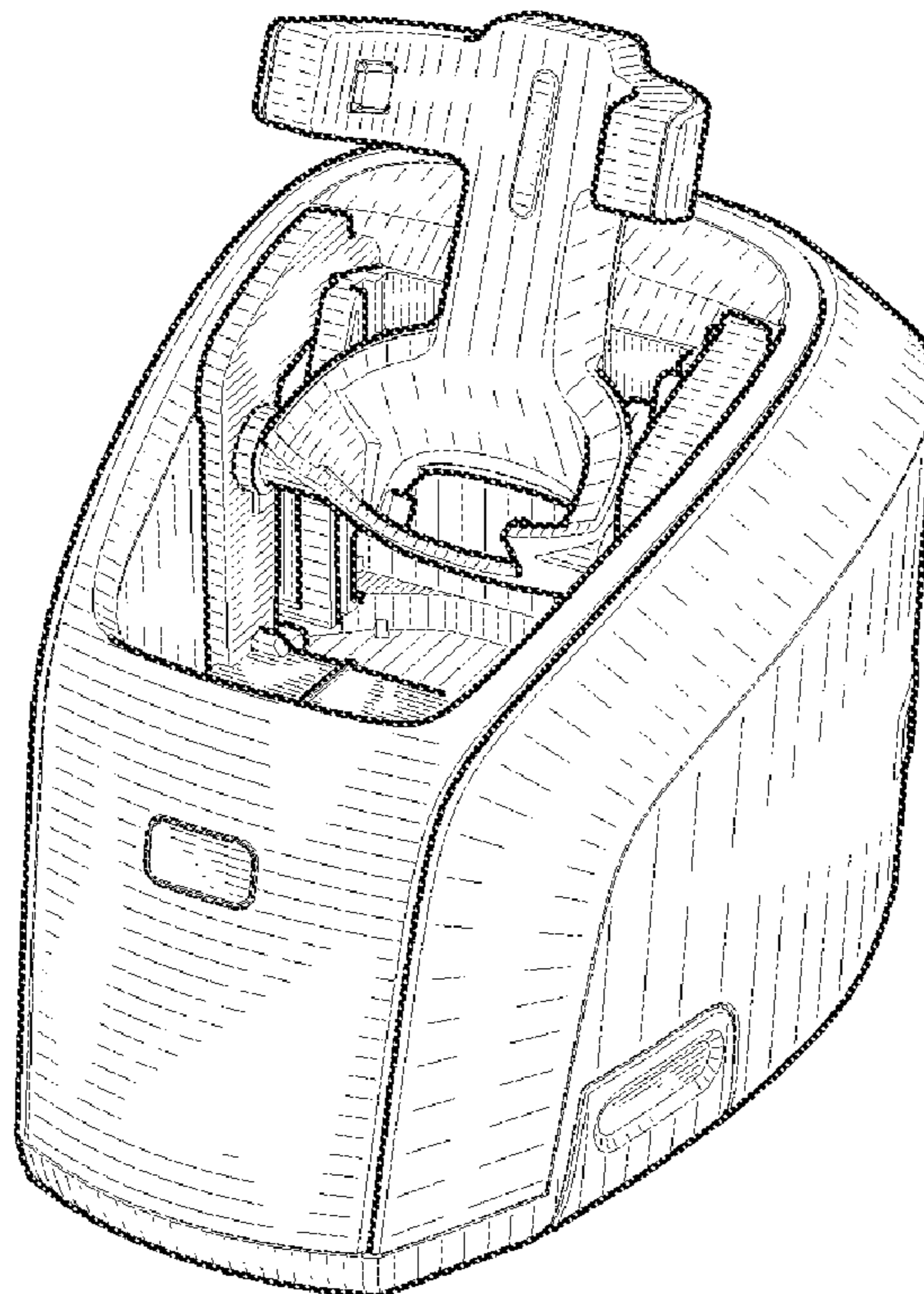

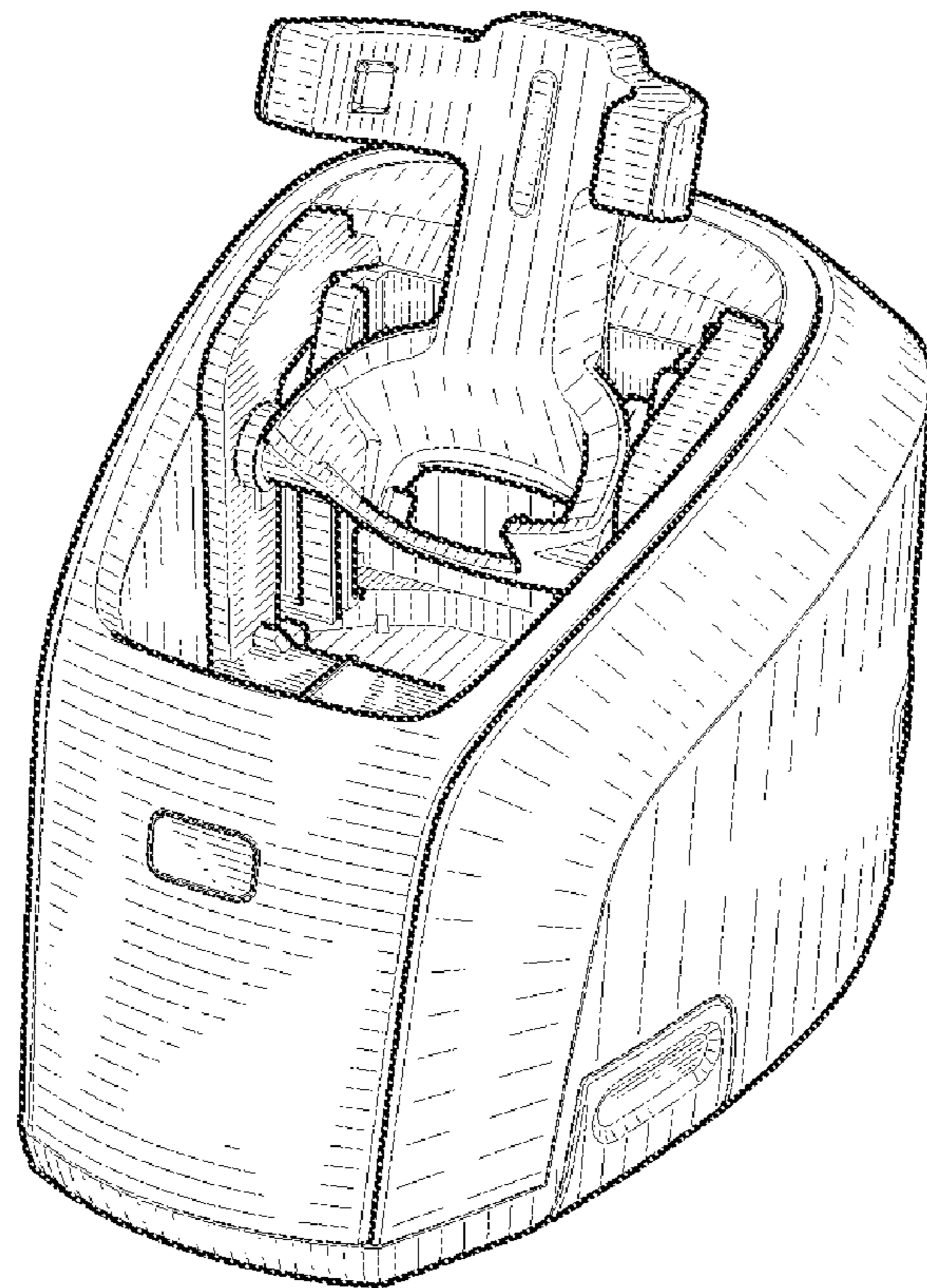

FIG. 1

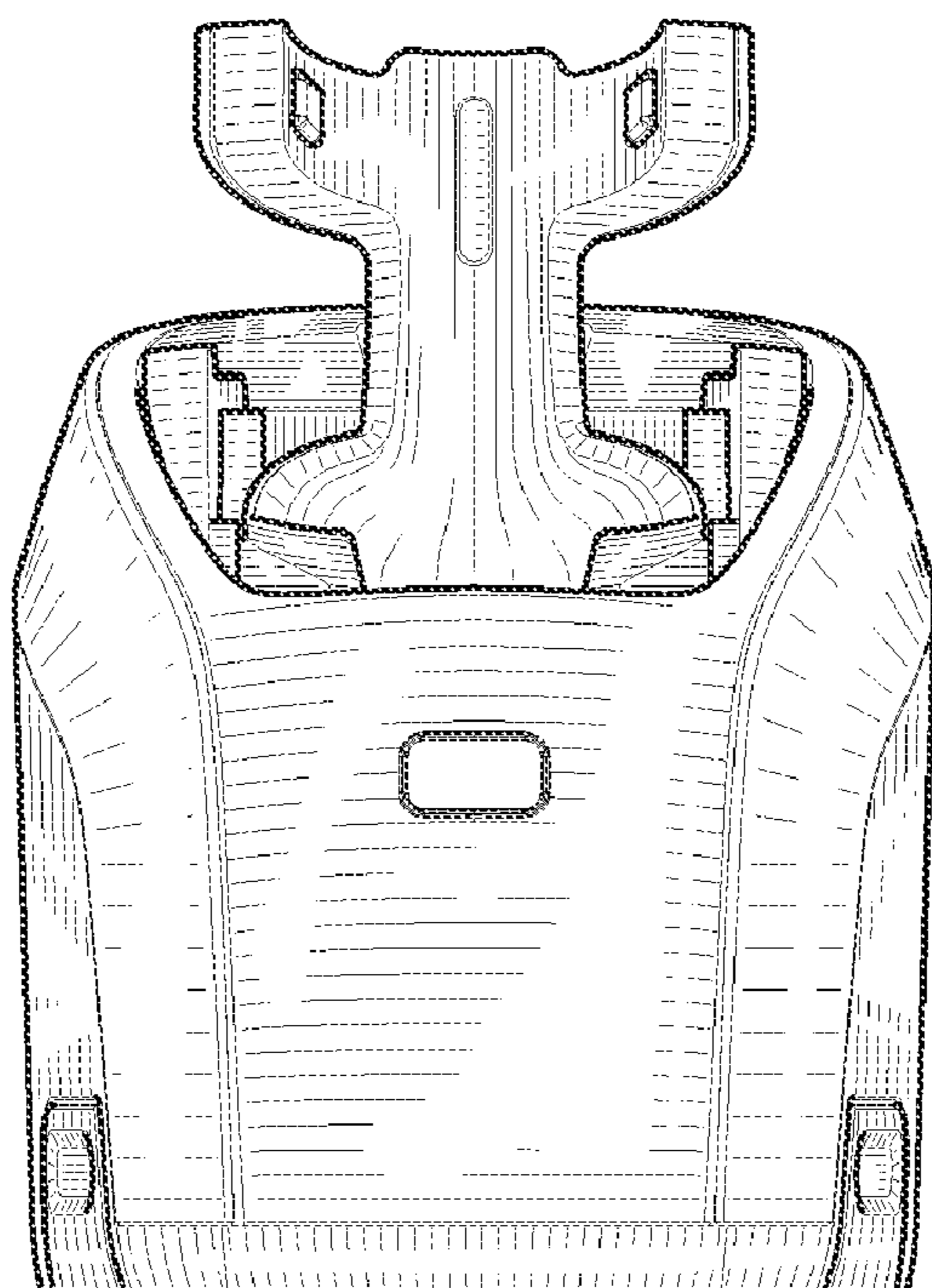

FIG. 2

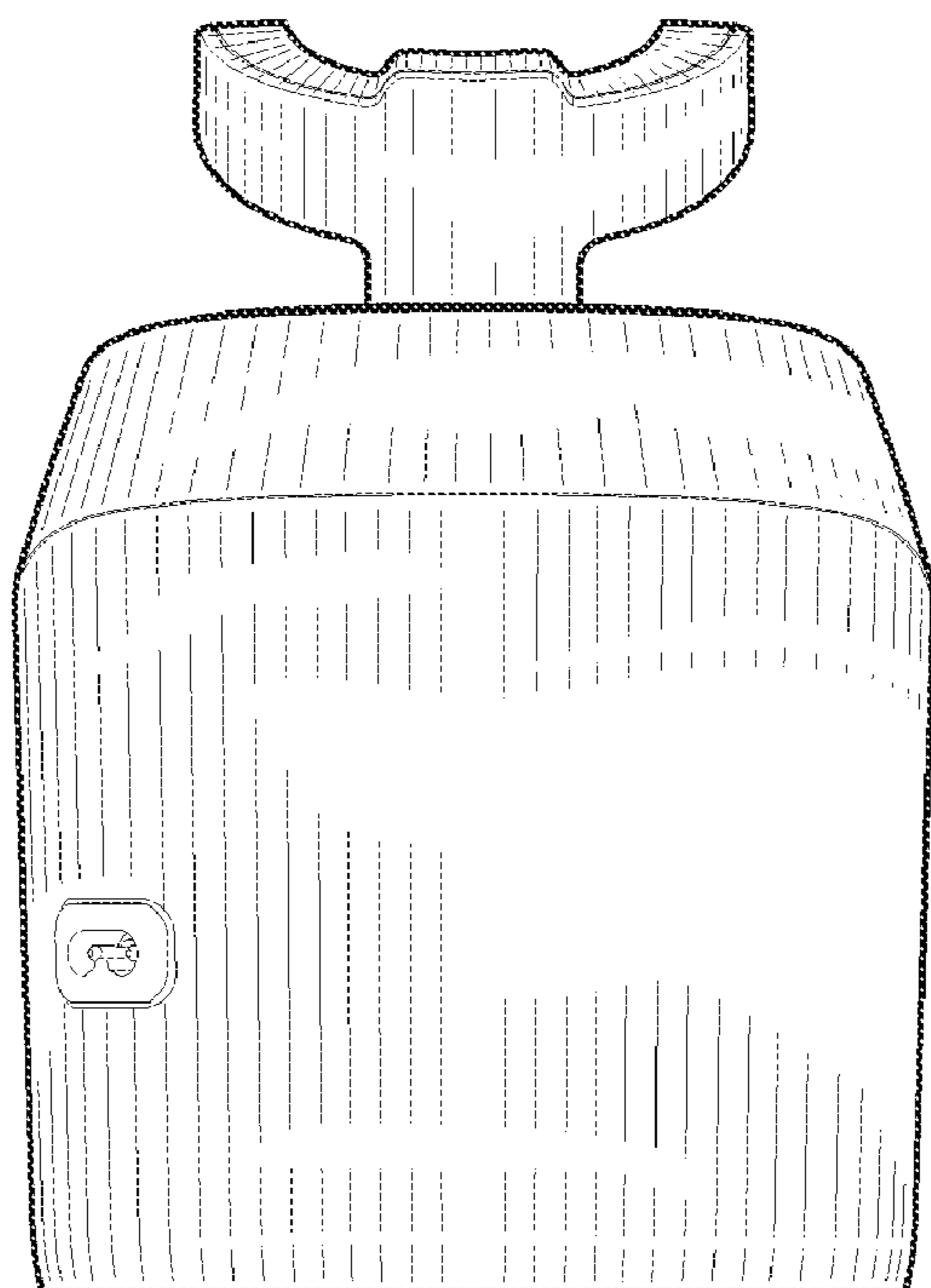

FIG. 3

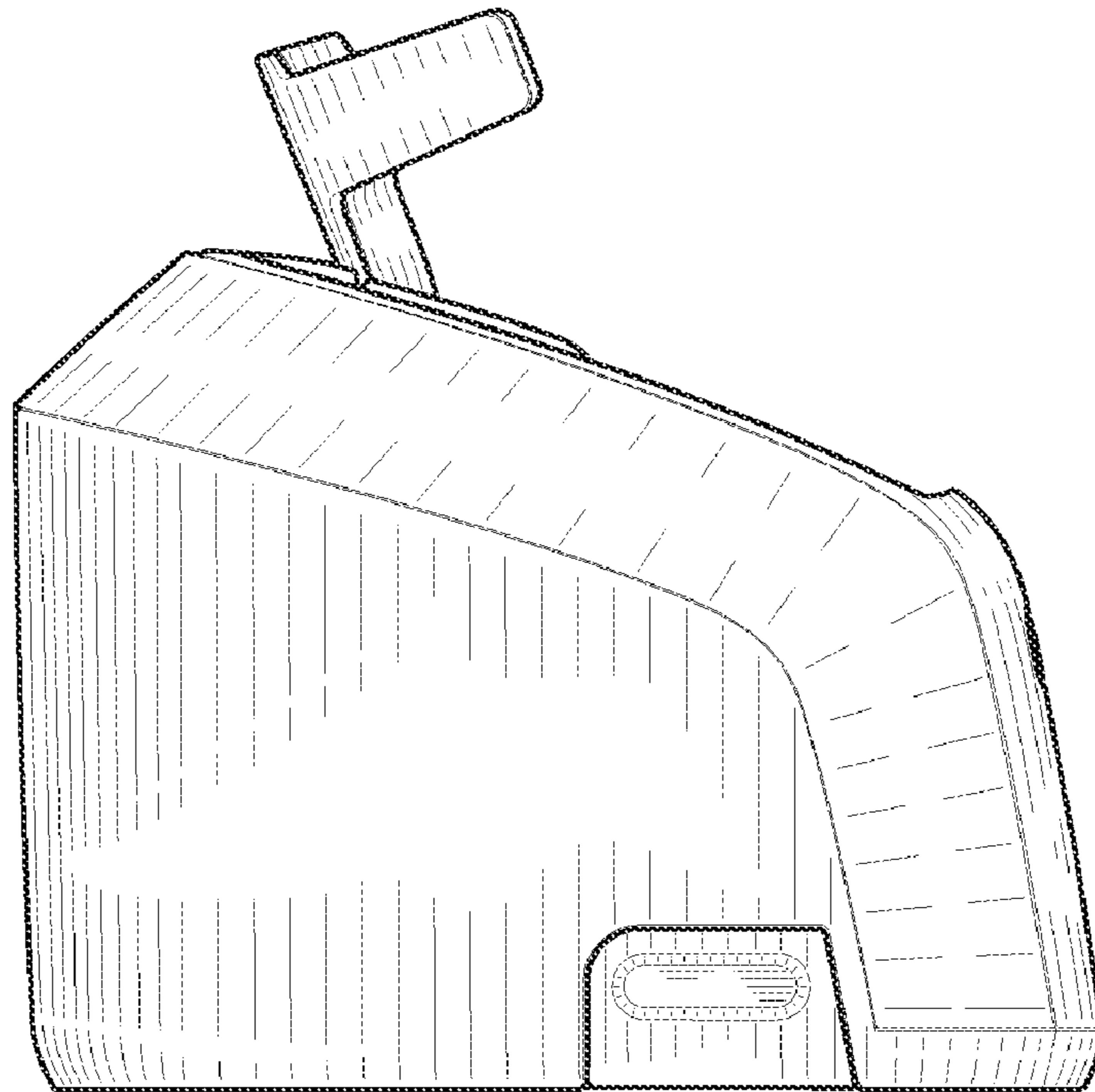

FIG. 4

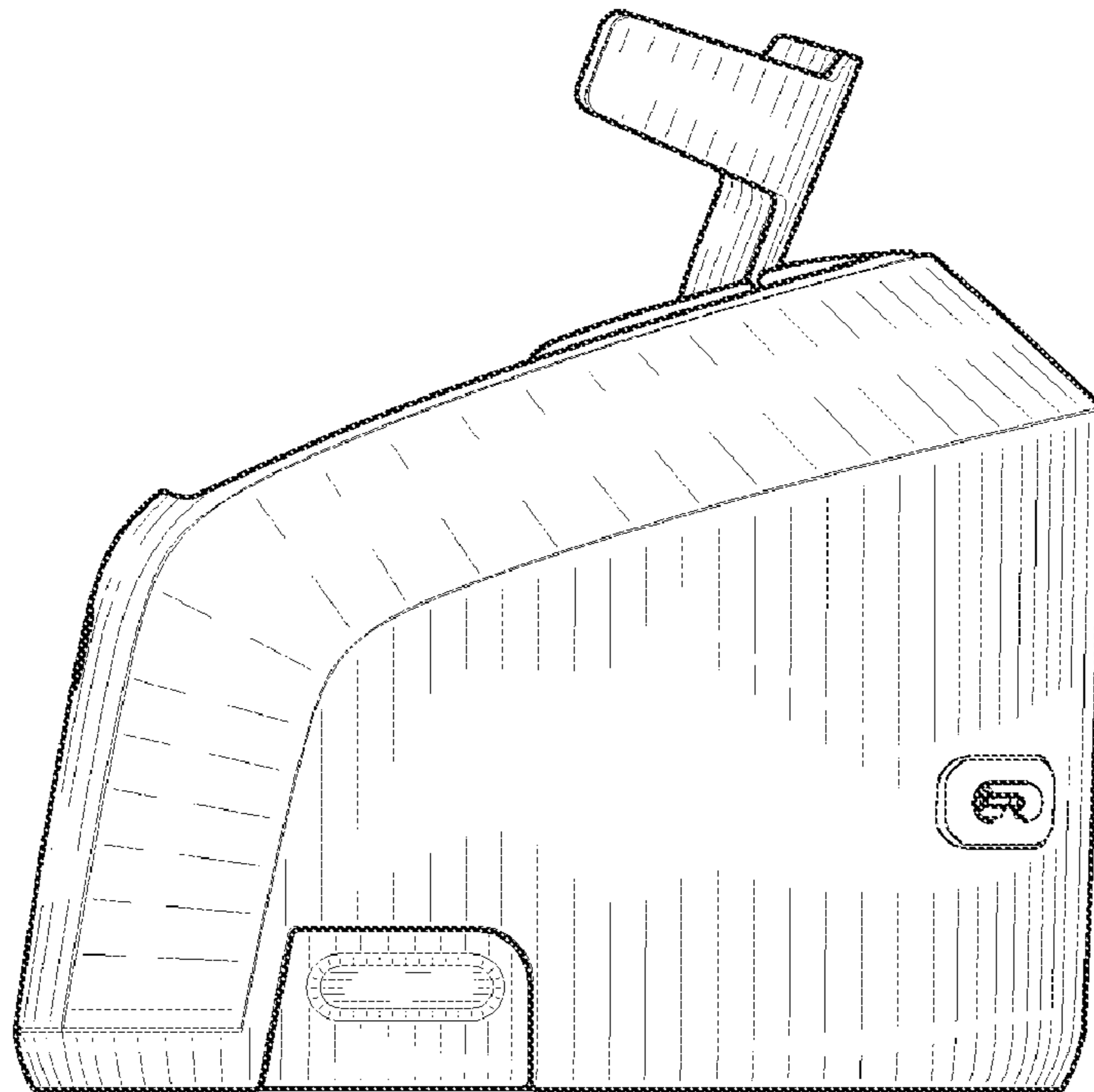

FIG. 5

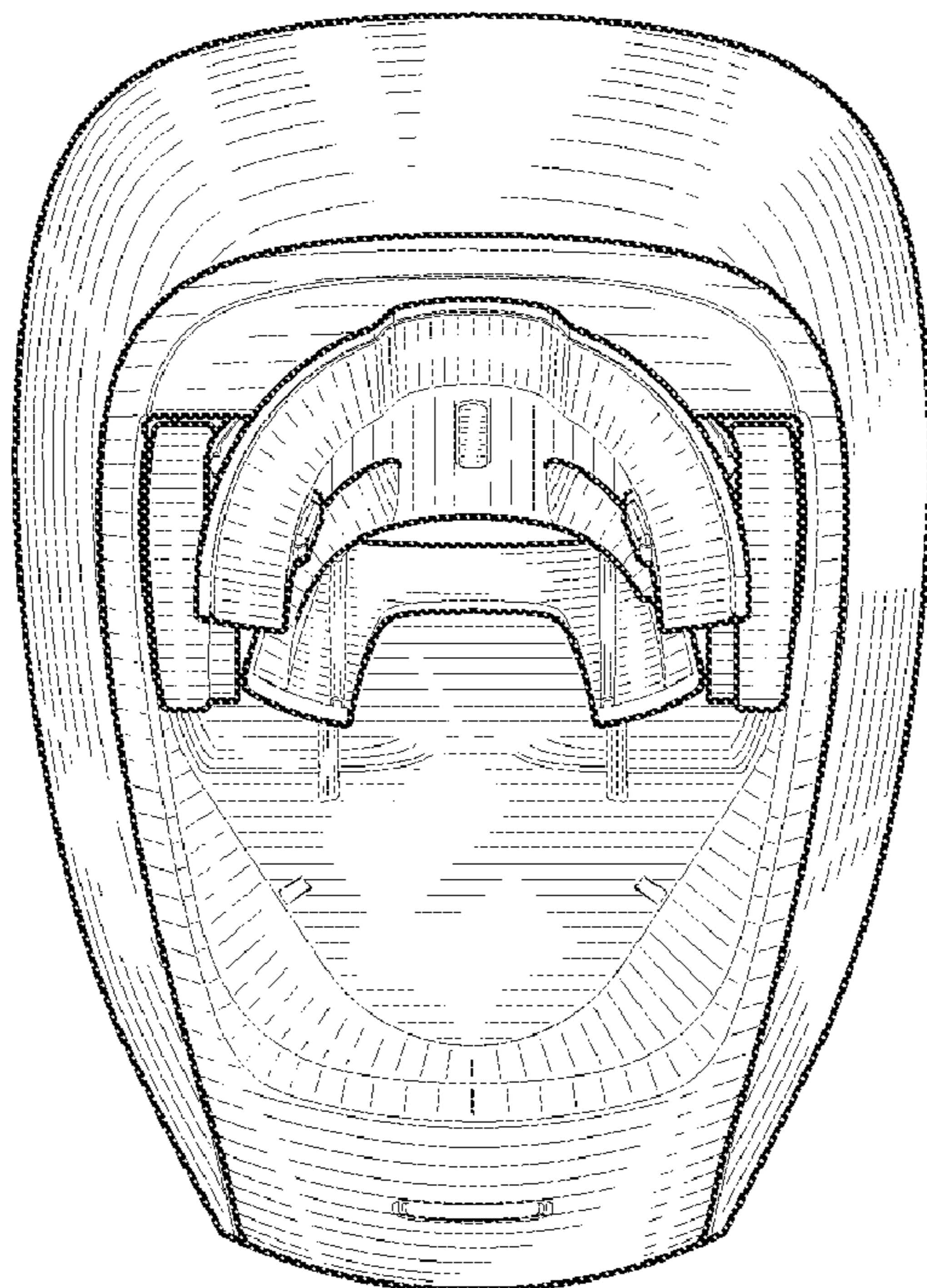

FIG. 6

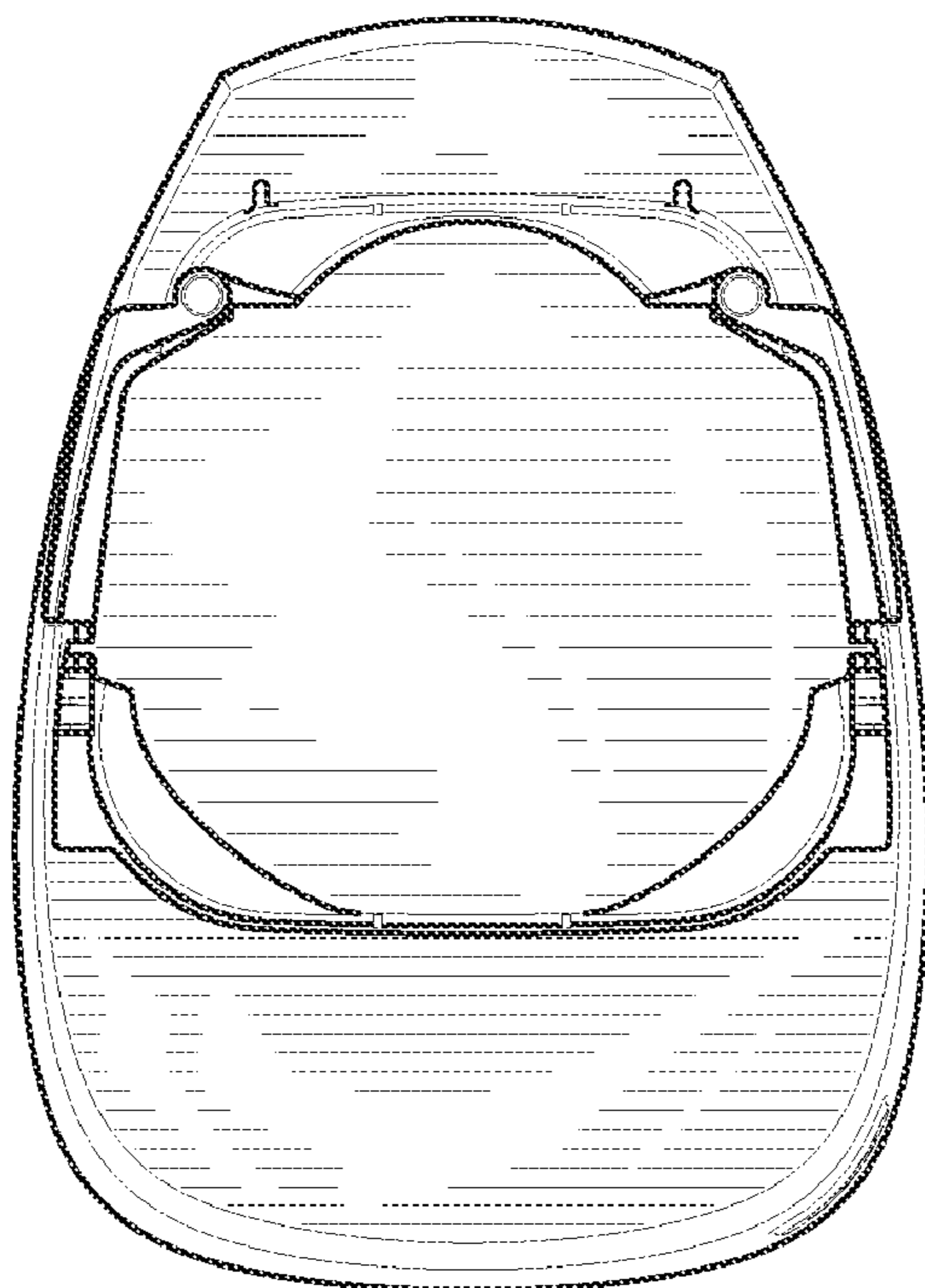

FIG. 7