



US00D580805S

(12) **United States Design Patent**  
**Lagerberg et al.**

(10) **Patent No.:** **US D580,805 S**

(45) **Date of Patent:** **\*\* Nov. 18, 2008**

(54) **ELECTRICAL TESTER**

(57) **CLAIM**

(75) Inventors: **Chris Lagerberg**, Seattle, WA (US);  
**Duncan Kearsley**, Stanwood, WA (US)

The ornamental design for an electrical tester, as shown and described.

(73) Assignee: **Fluke Corporation**, Everett, WA (US)

**DESCRIPTION**

(\*\*) Term: **14 Years**

FIG. 1 is an isometric view of an electrical tester constructed in accordance with one embodiment of the present disclosure; FIG. 2 is a top planar view of the electrical tester of FIG. 1; FIG. 3 is a bottom planar view of the electrical tester of FIG. 1;

(21) Appl. No.: **29/303,020**

FIG. 4 is a first side planar view of the electrical tester of FIG. 1;

(22) Filed: **Jan. 30, 2008**

(51) **LOC (8) Cl.** ..... **10-04**

FIG. 5 is a second side planar view of the electrical tester of FIG. 1;

(52) **U.S. Cl.** ..... **D10/78**

(58) **Field of Classification Search** ..... D10/78,  
D10/81; 324/66, 67, 158 P, 539-542; 379/1.01-10.03,  
379/21, 60, 66, 96, 106.01-106.11  
See application file for complete search history.

FIG. 6 is a first end planar view of the electrical tester of FIG. 1;

(56) **References Cited**

**U.S. PATENT DOCUMENTS**

FIG. 7 is a second end planar view of the electrical tester of FIG. 1;

4,600,810	A *	7/1986	Feldman et al.	.....	379/21
D400,455	S *	11/1998	Fisher	.....	D10/78
D416,819	S *	11/1999	Luebke et al.	.....	D10/78
D446,736	S *	8/2001	Chen	.....	D10/78
D461,730	S *	8/2002	Luebke et al.	.....	D10/78
6,674,276	B2 *	1/2004	Wiesemann et al.	.....	324/67
D497,817	S *	11/2004	Lord	.....	D10/78
D518,397	S *	4/2006	Sydrowski et al.	.....	D10/78
D520,888	S *	5/2006	Sydrowski et al.	.....	D10/78
D560,528	S *	1/2008	Chen	.....	D10/78
D570,717	S *	6/2008	Elrod	.....	D10/78

FIG. 8 is an isometric view of an electrical tester constructed in accordance with another embodiment of the present disclosure;

FIG. 9 is a top planar view of the electrical tester of FIG. 8;

FIG. 10 is a bottom planar view of the electrical tester of FIG. 8;

FIG. 11 is a first side planar view of the electrical tester of FIG. 8;

FIG. 12 is a second side planar view of the electrical tester of FIG. 8;

FIG. 13 is a first end planar view of the electrical tester of FIG. 8; and,

FIG. 14 is a second end planar view of the electrical tester of FIG. 8.

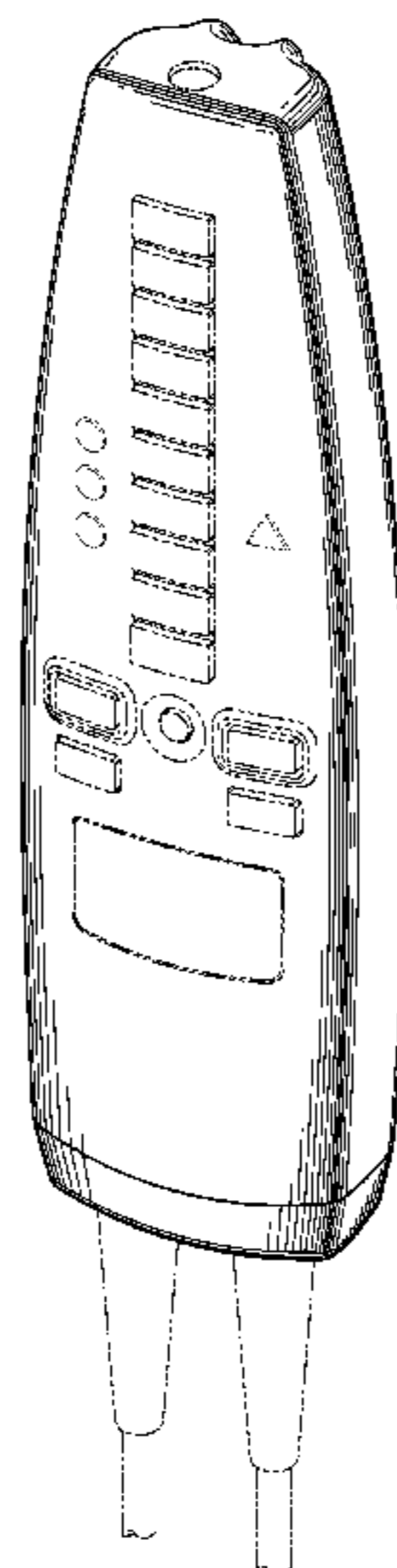
The subject matter shown in phantom lines is hereby disclaimed and forms no part of the claimed invention.

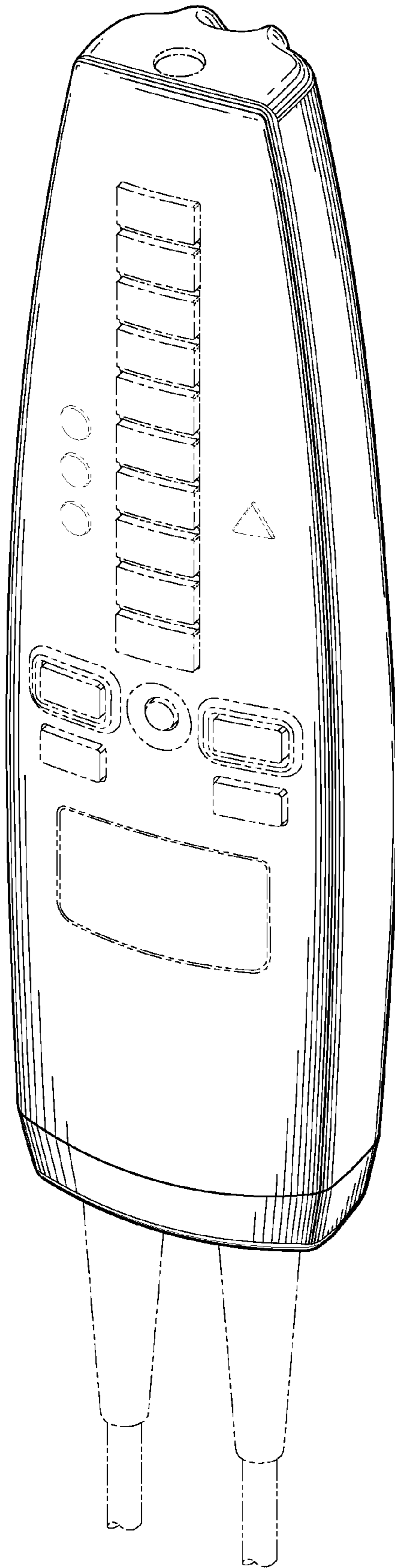
\* cited by examiner

*Primary Examiner*—Antoine D Davis

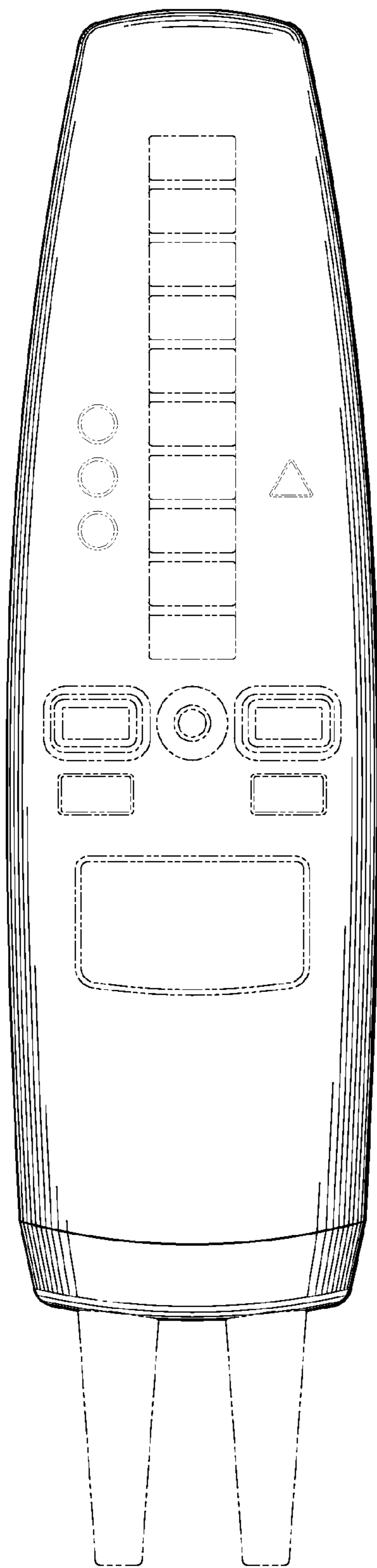
(74) *Attorney, Agent, or Firm*—Christensen O'Connor Johnson Kindness PLLC

**1 Claim, 6 Drawing Sheets**

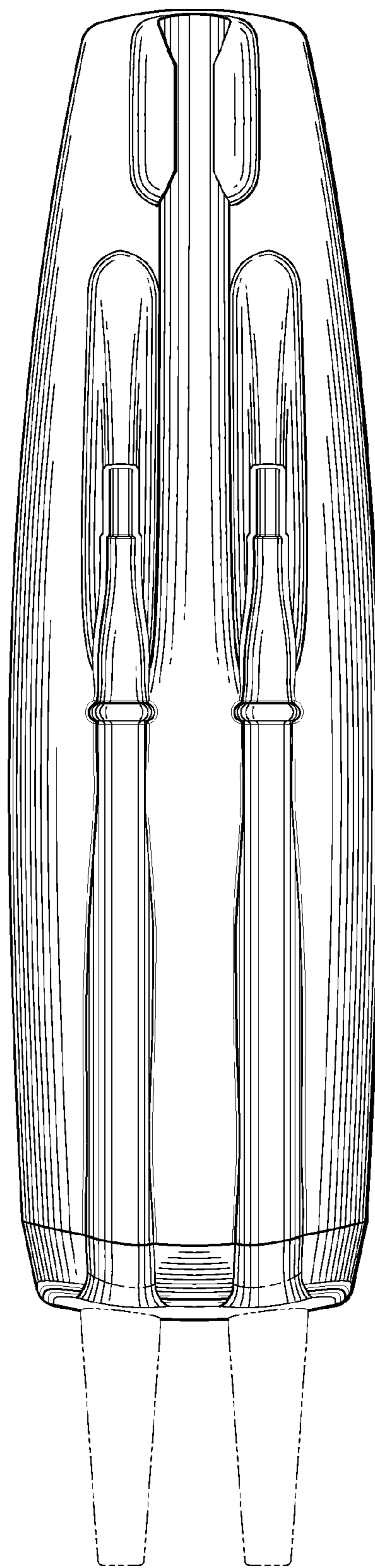




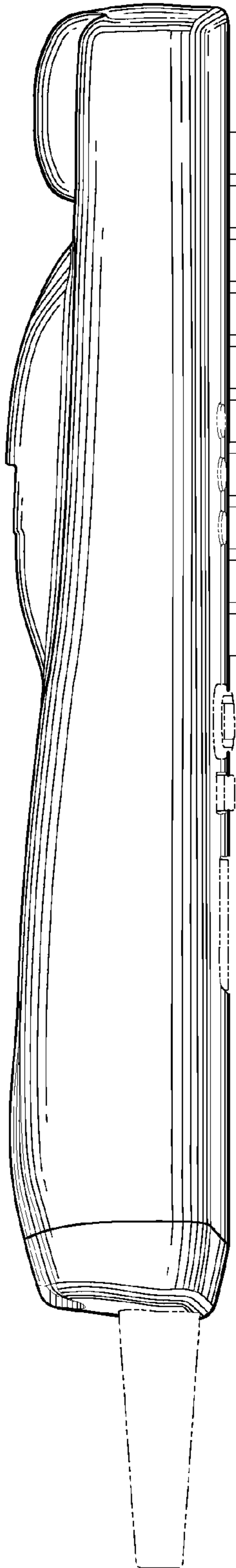
*Fig.1.*



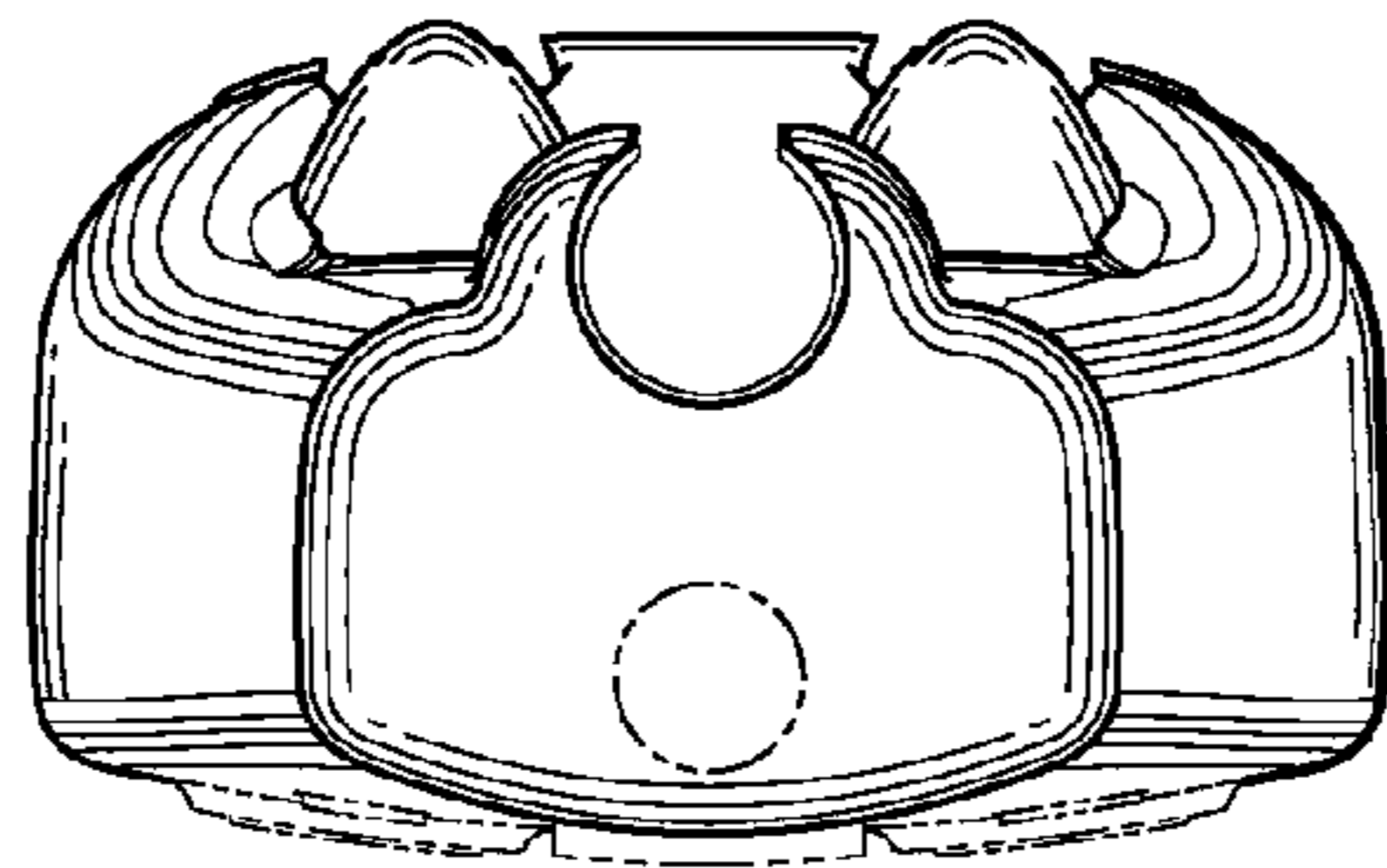
***Fig. 2.***



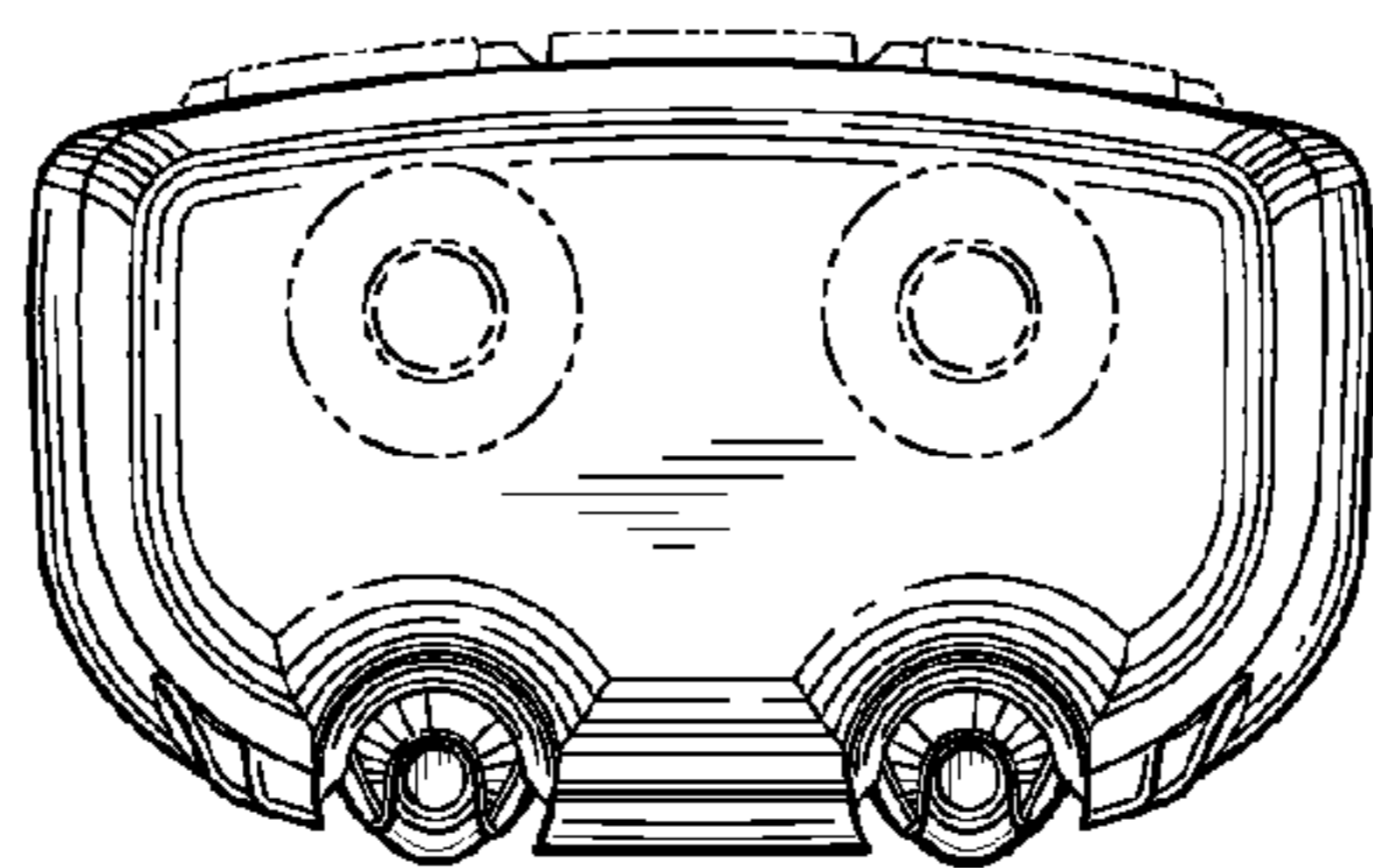
***Fig. 3.***



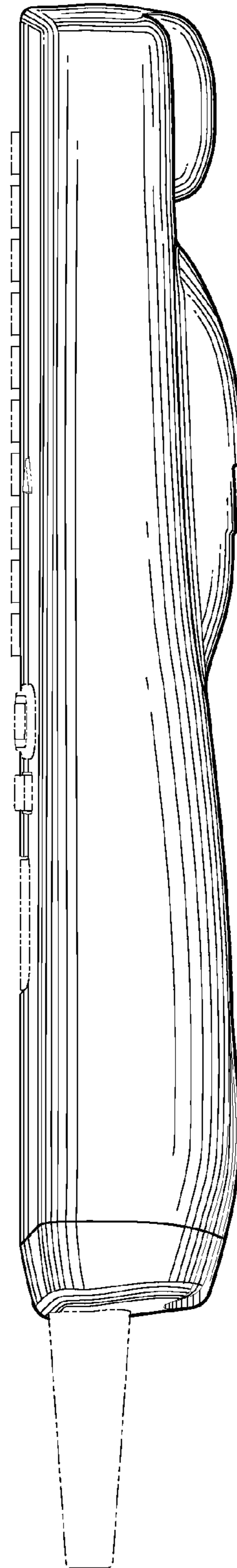
*Fig. 4.*



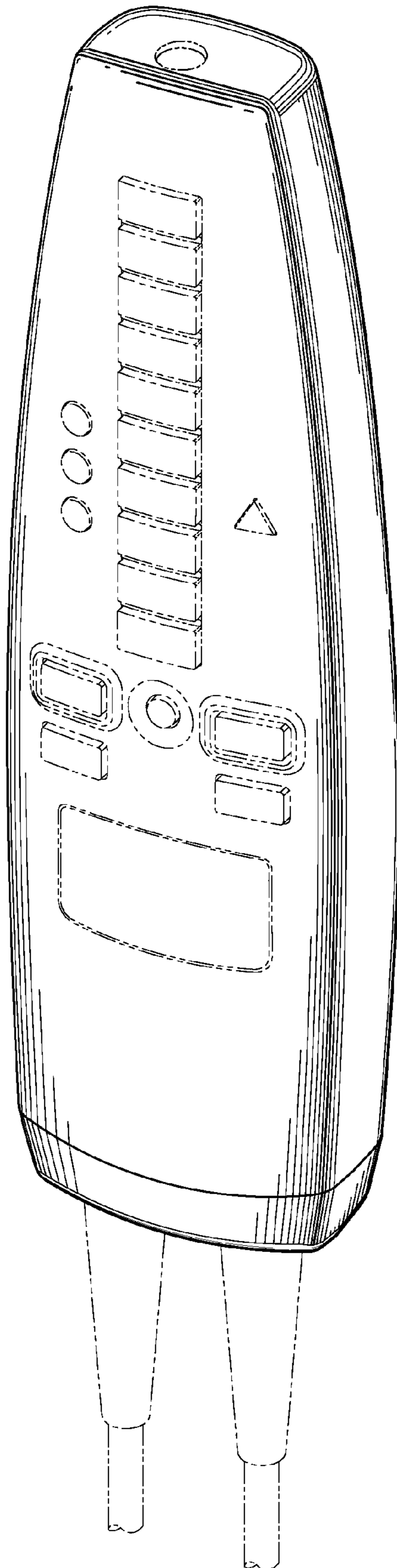
*Fig. 6.*



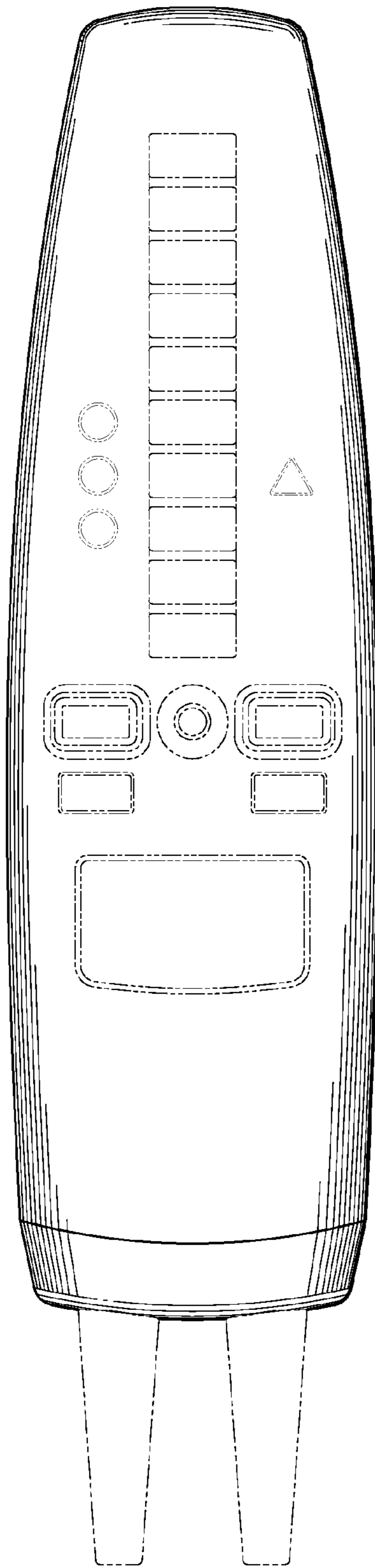
*Fig. 7.*



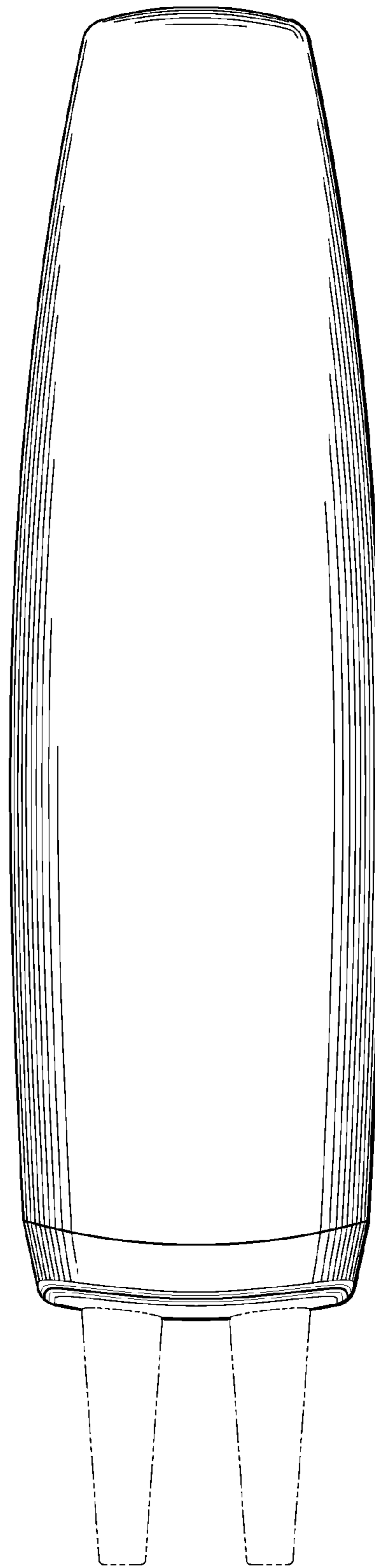
*Fig. 5.*



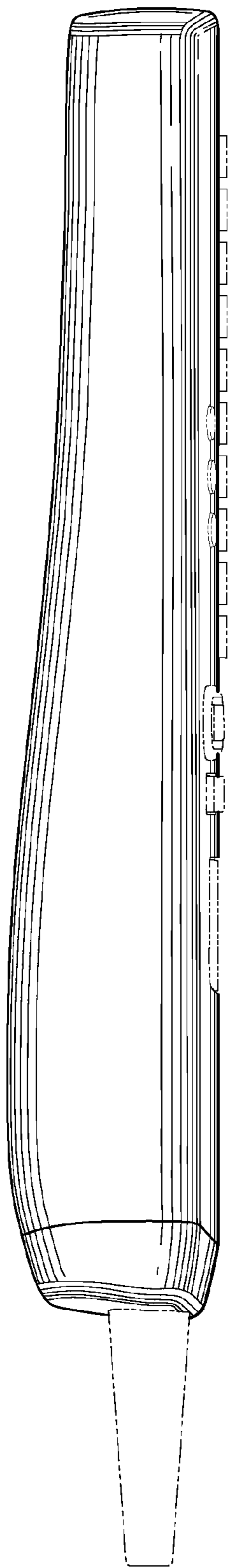
*Fig. 8.*



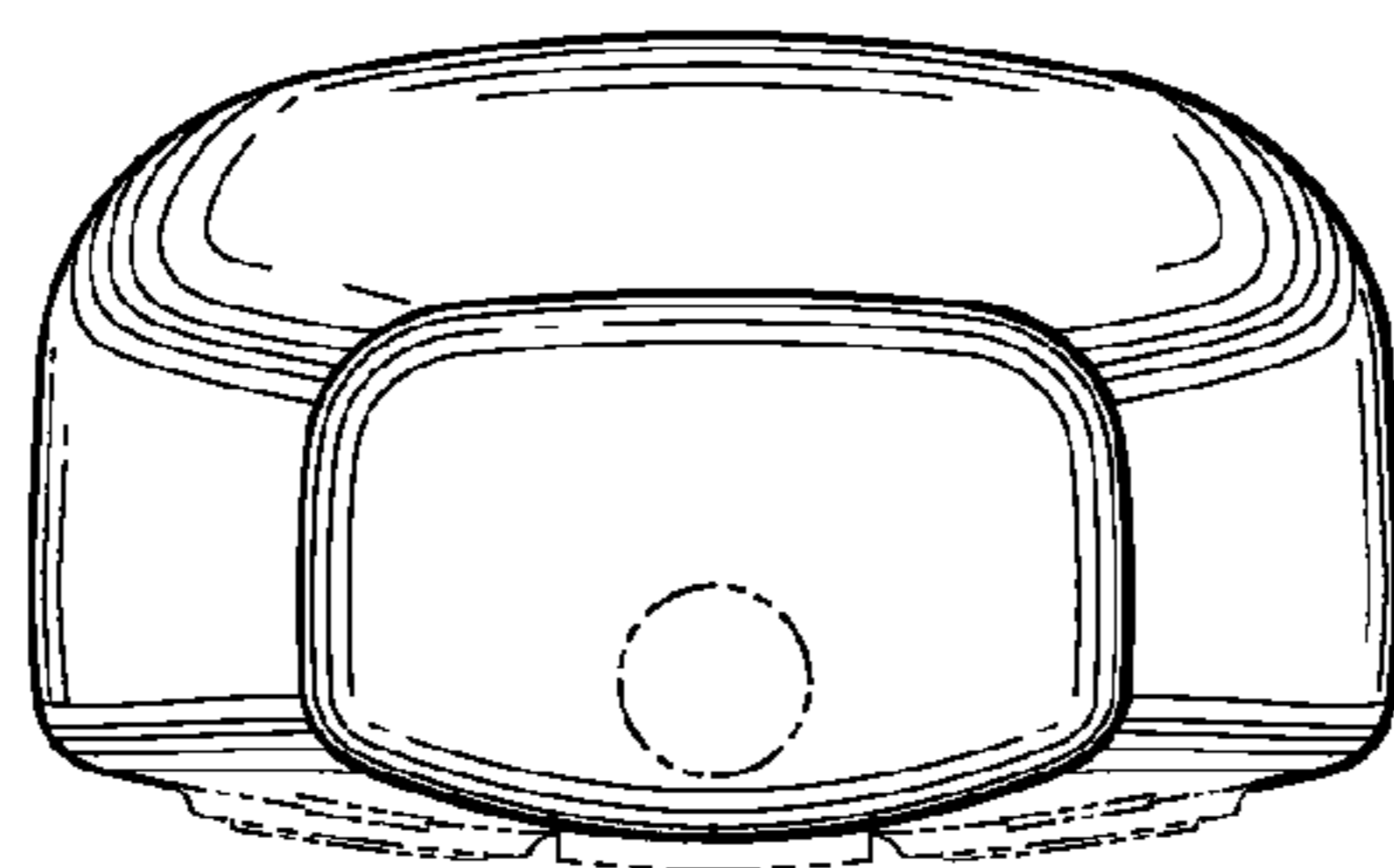
***Fig. 9.***



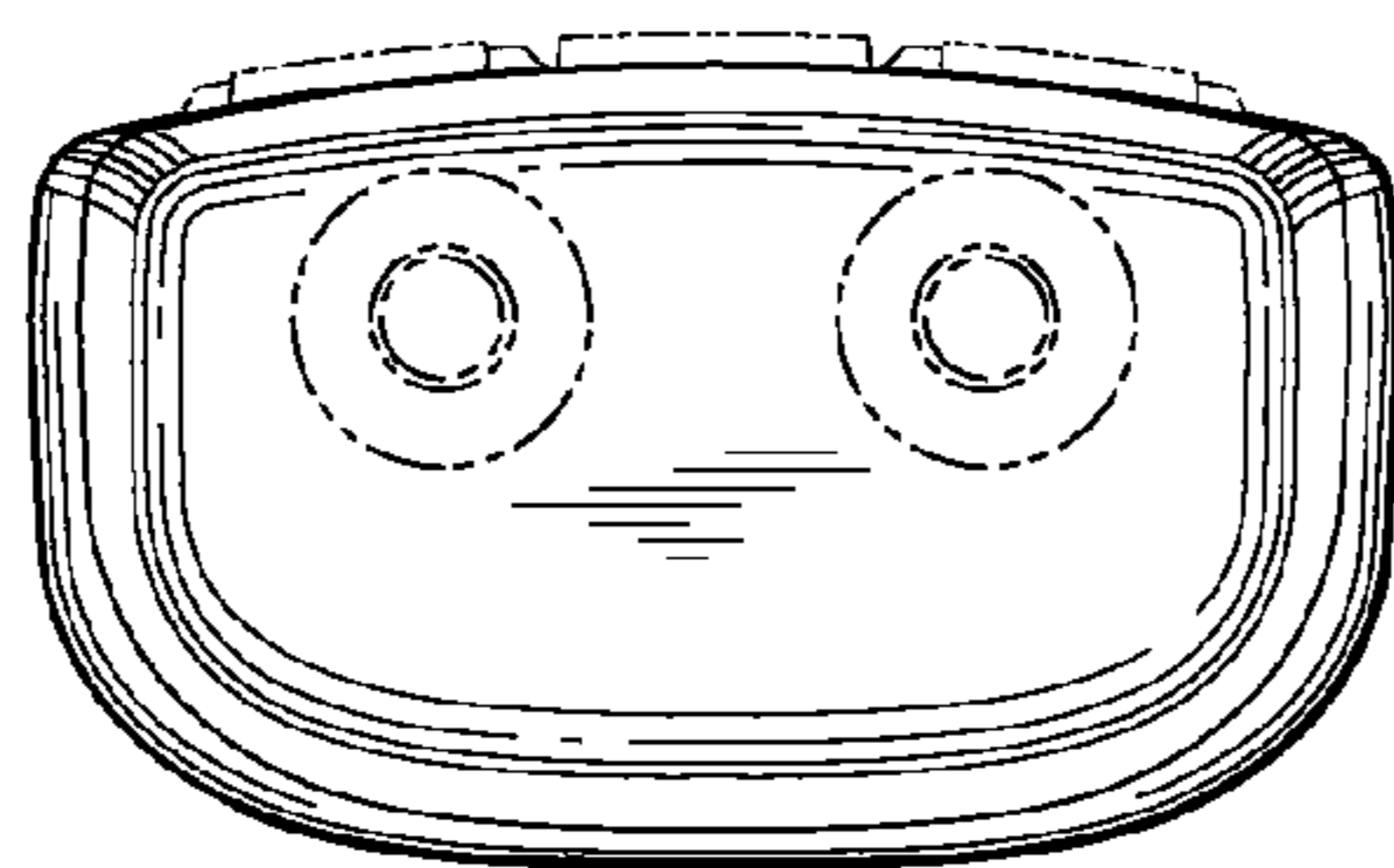
***Fig. 10.***



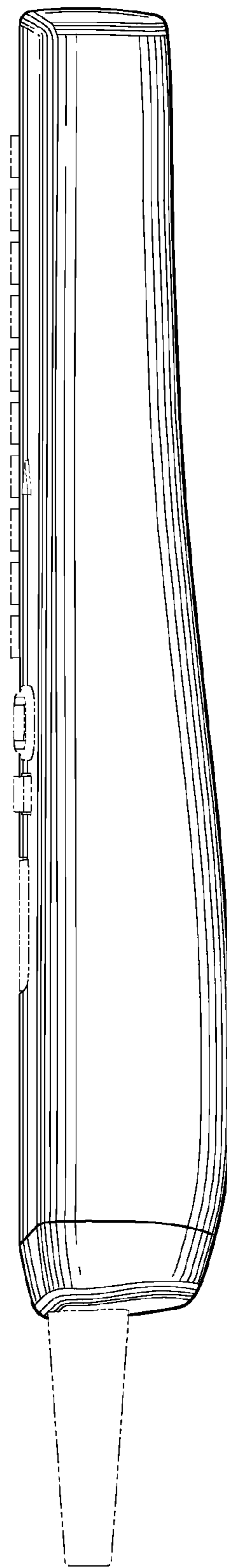
*Fig. 11.*



*Fig. 13.*



*Fig. 14.*



*Fig. 12.*