



US00D580620S

(12) **United States Design Patent**  
**Sellers et al.**

(10) **Patent No.:** **US D580,620 S**

(45) **Date of Patent:** **\*\* Nov. 11, 2008**

(54) **SKI EQUIPMENT TRANSPORT APPARATUS**

(75) Inventors: **David R. Sellers**, 3305 County Road 96, Ward, CO (US) 80481; **Deanna L. Griffith**, Topanga, CA (US); **Daniel W. Ashcraft**, Torrance, CA (US); **Gregory S. Thüne**, Hollywood, CA (US)

(73) Assignee: **David R. Sellers**, Ward, CO (US)

(\*\*) Term: **14 Years**

(21) Appl. No.: **29/263,842**

(22) Filed: **Jul. 27, 2006**

**Related U.S. Application Data**

(63) Continuation of application No. 11/444,736, filed on May 31, 2006.

(51) **LOC (8) Cl.** ..... **12-02**

(52) **U.S. Cl.** ..... **D34/24**

(58) **Field of Classification Search** ..... D34/12-27;  
280/814, 645, 47.18, 35, 809, 655  
See application file for complete search history.

(56) **References Cited**

**U.S. PATENT DOCUMENTS**

3,504,921 A *	4/1970	Osmond	.....	280/8
4,114,915 A	9/1978	Lello et al.		
4,268,050 A	5/1981	Kennedy, Sr.		
4,358,137 A	11/1982	Gramm		
4,856,811 A	8/1989	Bressler et al.		
5,106,112 A	4/1992	Sargent		

5,240,285 A	8/1993	Harris		
5,277,449 A	1/1994	Schmidt		
5,340,153 A *	8/1994	Parker	.....	280/814
6,070,906 A	6/2000	Allen		
6,086,102 A	7/2000	Stark et al.		
6,848,718 B2	2/2005	Ravikumar et al.		
2005/0236830 A1 *	10/2005	Moller	.....	280/814

\* cited by examiner

*Primary Examiner*—Cynthia E Ramirez

(74) *Attorney, Agent, or Firm*—Daniel P. Dooley; Fellers, Snider, et al.

(57) **CLAIM**

The ornamental design for a ski equipment transport apparatus, as shown and described.

**DESCRIPTION**

FIG. 1 is a front elevational view of a ski equipment transport apparatus showing our new design.

FIG. 2 is a rear elevational view thereof.

FIG. 3 is an enlarged right side elevational view thereof.

FIG. 4 is an enlarged left side elevational view thereof.

FIG. 5 is a top plan view thereof; and,

FIG. 6 is a bottom plan view in another position.

The broken lines are of the Alpine skis and poles, and are not part of the new inventive ski equipment transport apparatus. The broken lines have been added to enhance an understanding of the new inventive ski equipment transport apparatus, and form no part of the claimed design.

**1 Claim, 6 Drawing Sheets**

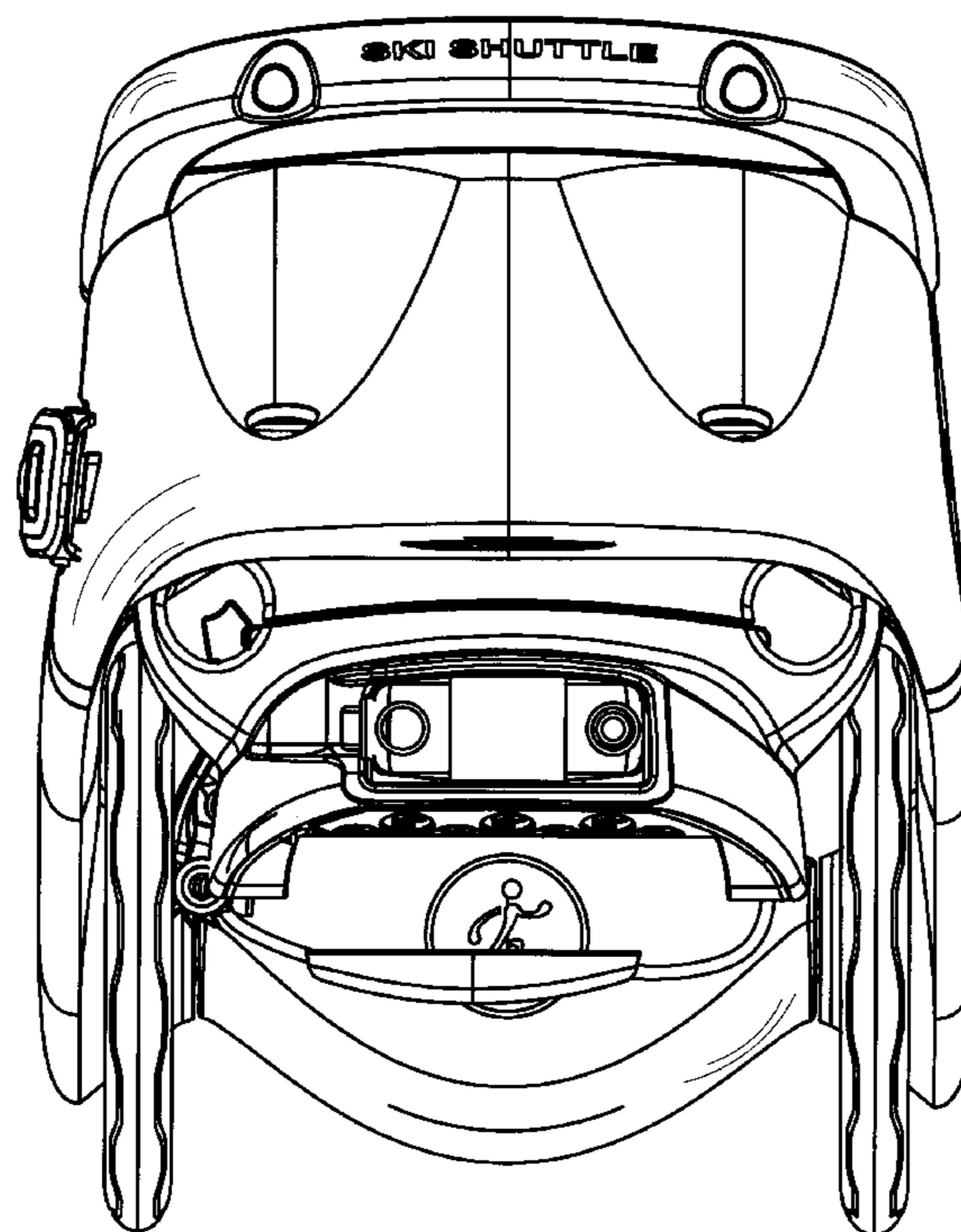

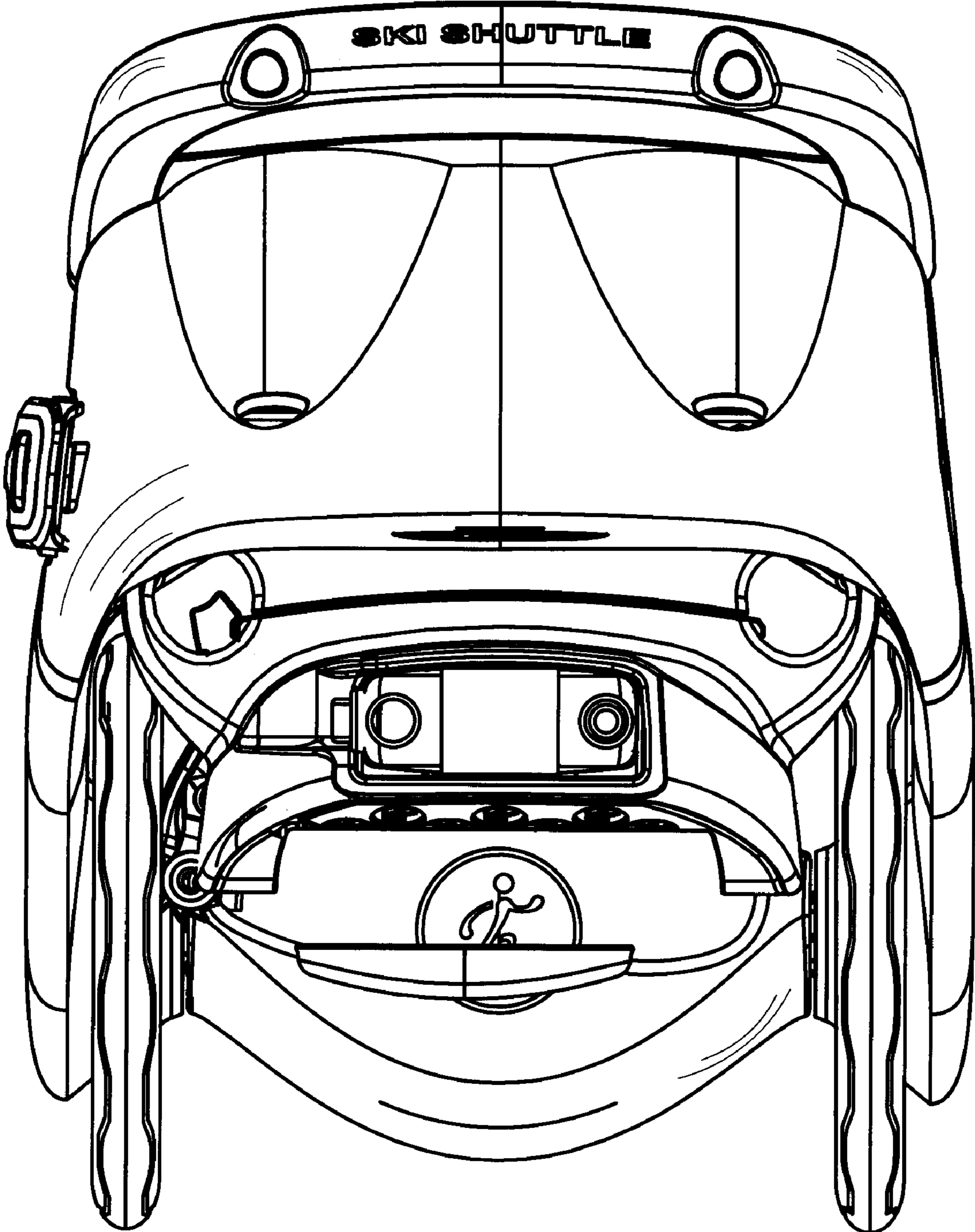

FIG. 1

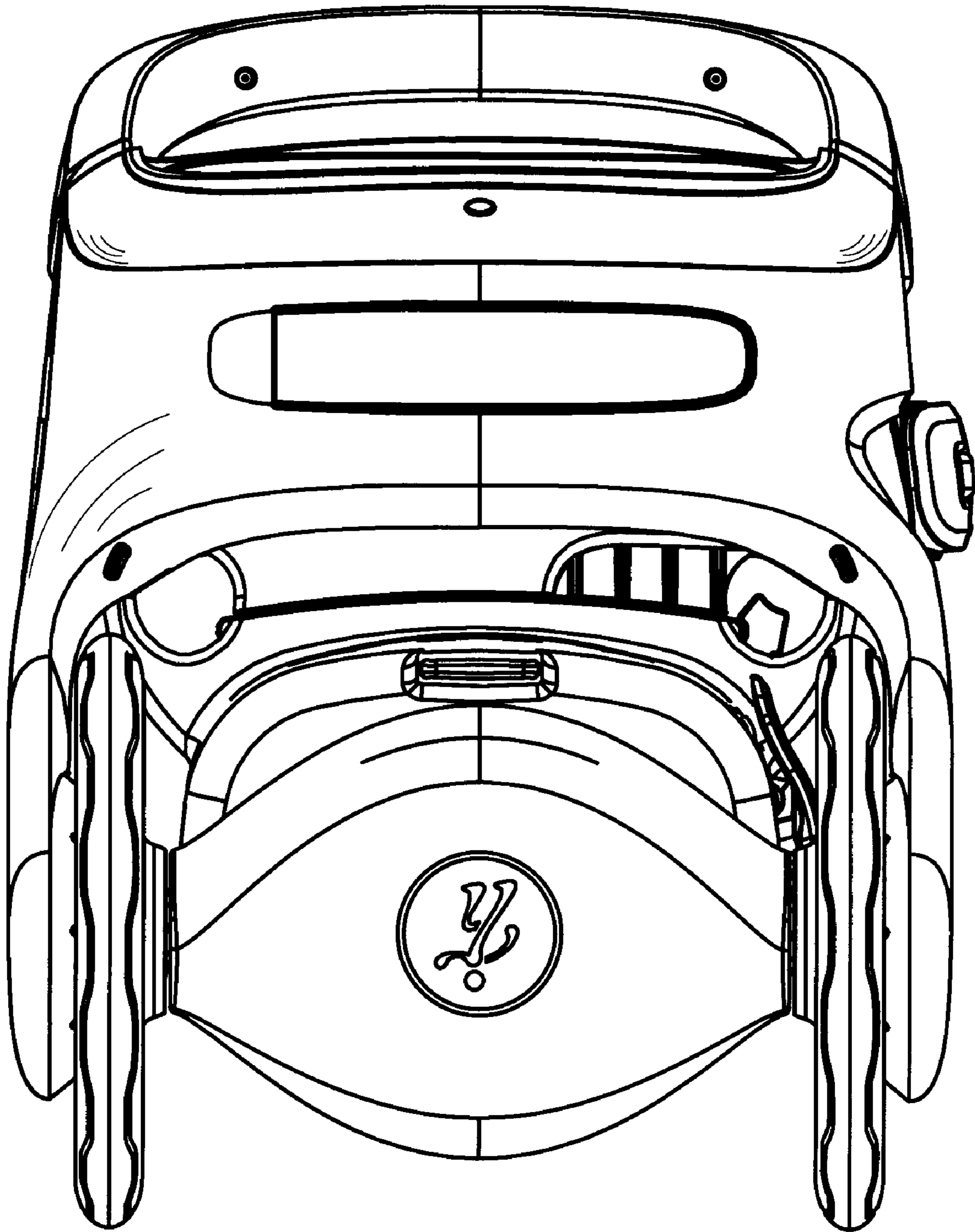

FIG. 2

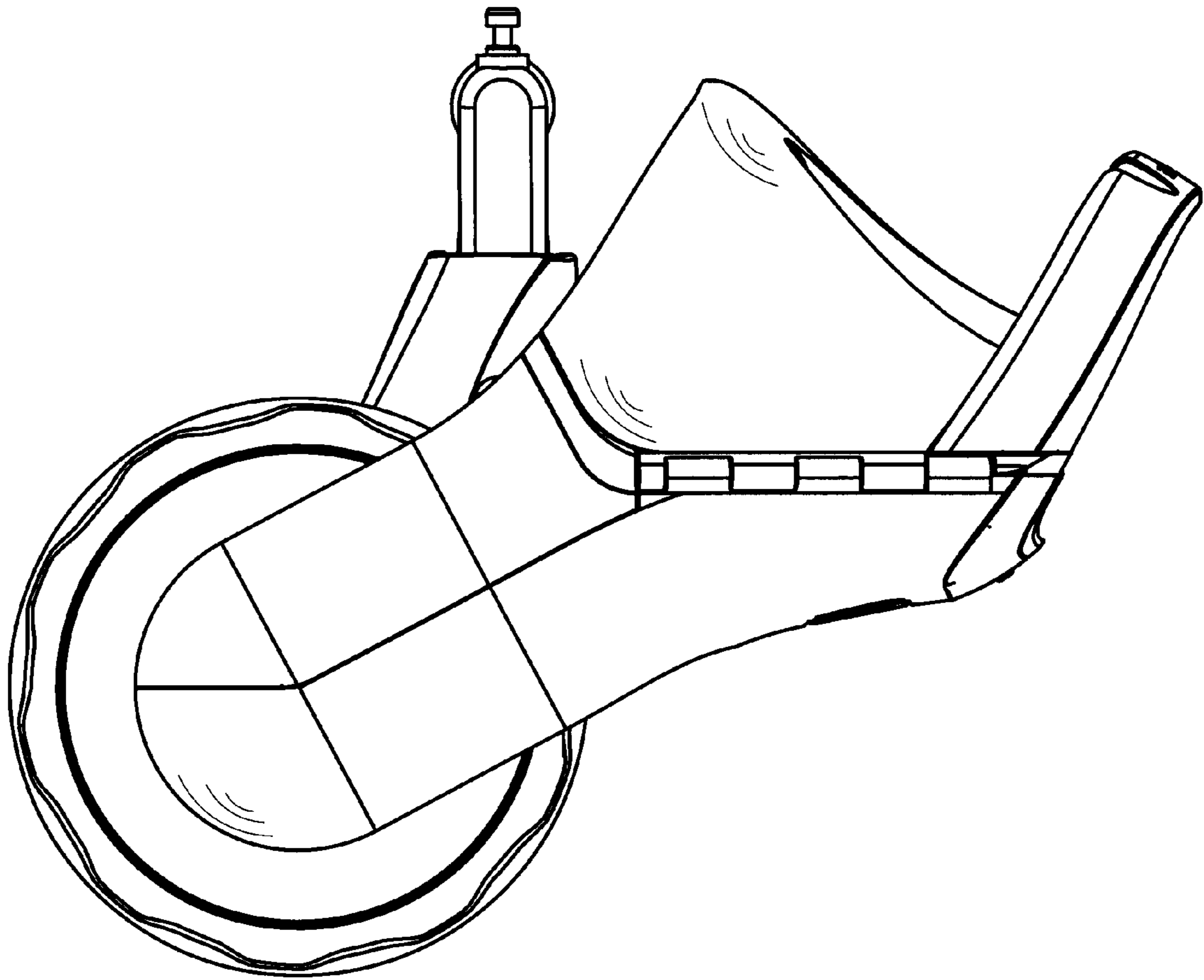

FIG. 3

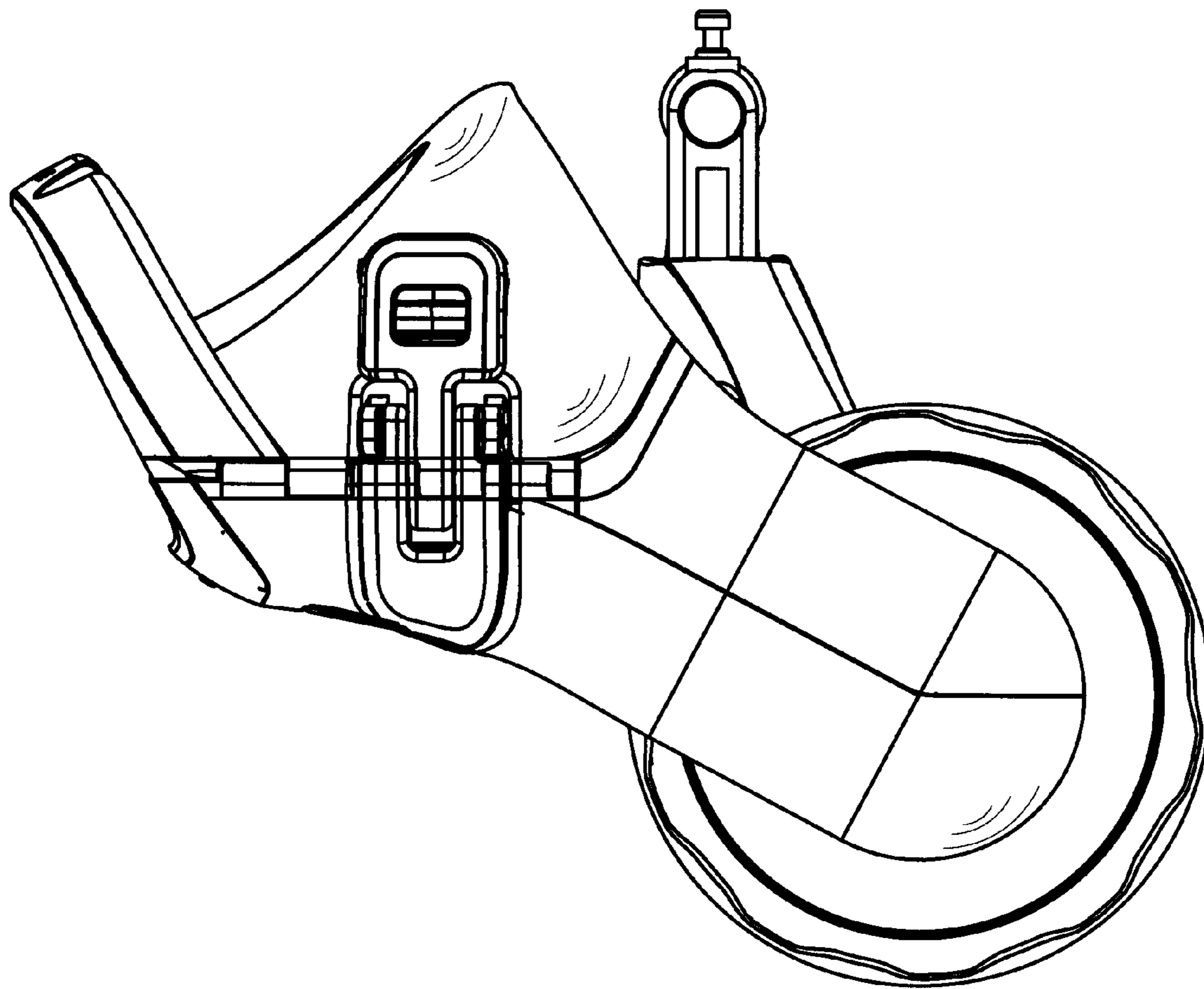

FIG. 4

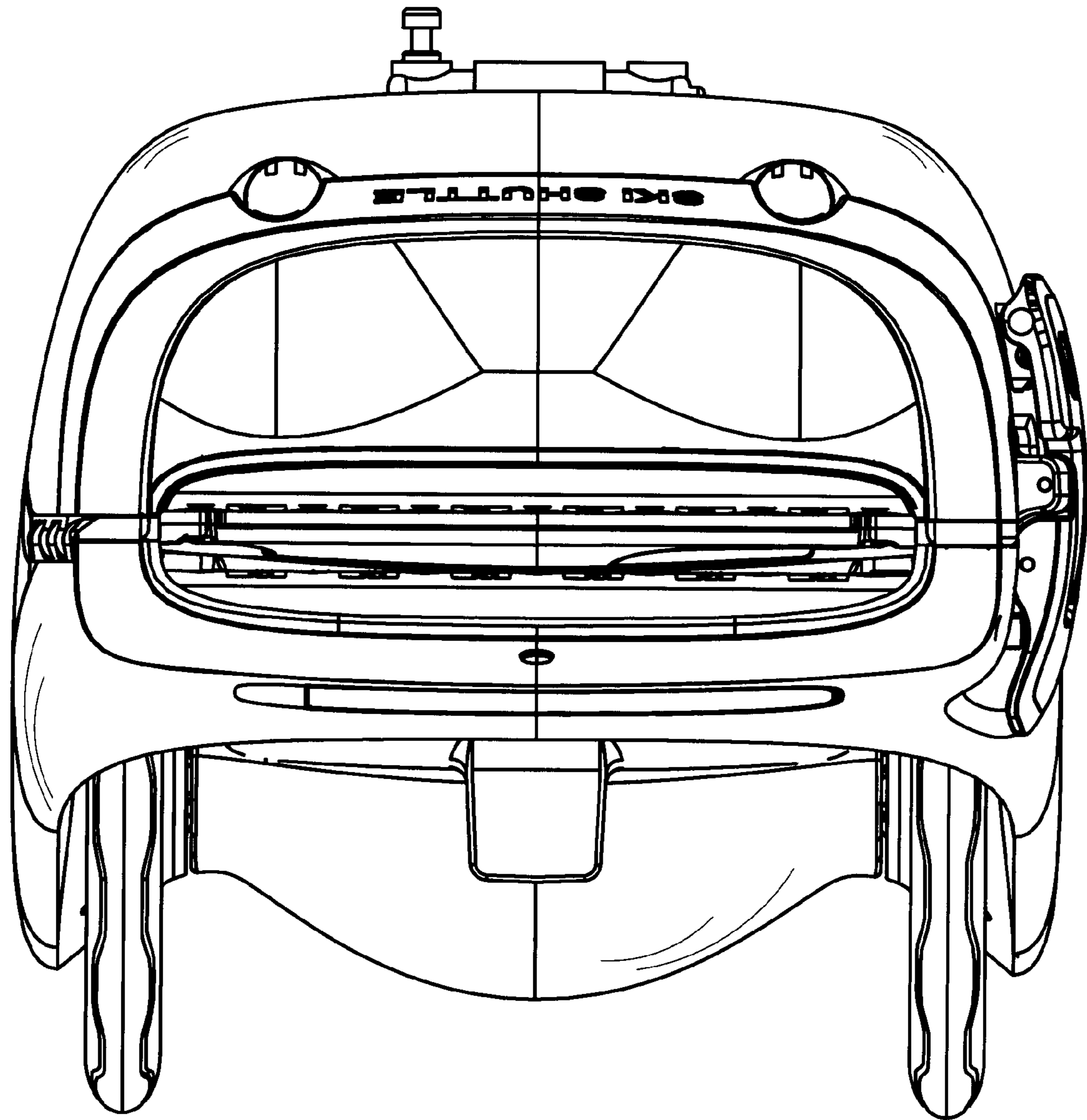

FIG. 5

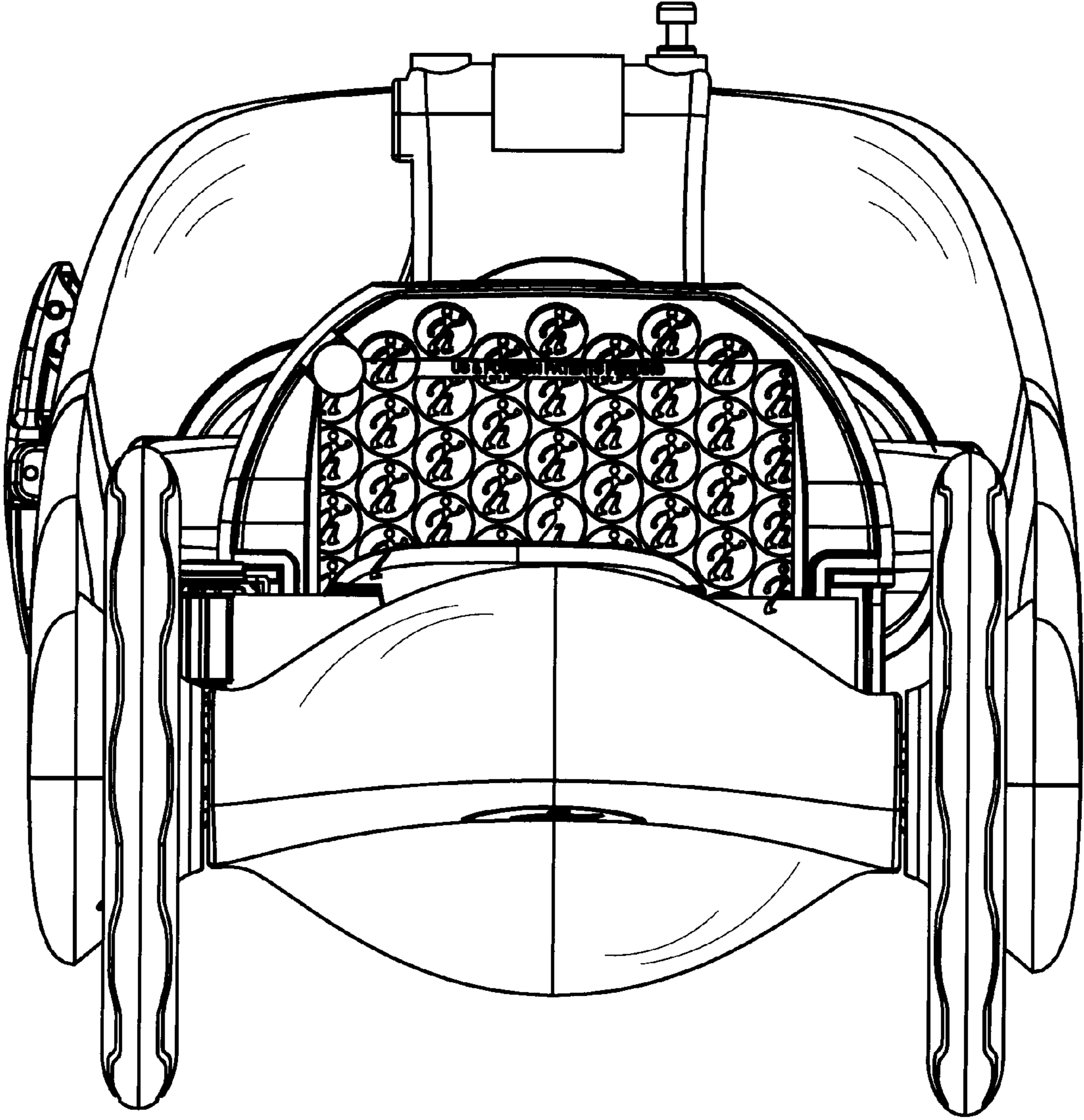

FIG. 6