



US00D580482S

(12) **United States Design Patent**  
**Munakata et al.**

(10) **Patent No.:** **US D580,482 S**

(45) **Date of Patent:** **\*\* Nov. 11, 2008**

(54) **DRY ELECTROSTATIC COPYING MACHINE**

(75) Inventors: **Takashi Munakata**, Kanagawa (JP);  
**Aya Masuda**, Tokyo (JP); **Masanao Takahashi**, Tokyo (JP); **Yoshihisa Minakawa**, Tokyo (JP)

(73) Assignee: **Ricoh Company, Ltd.**, Tokyo (JP)

(\*\*) Term: **14 Years**

(21) Appl. No.: **29/292,856**

(22) Filed: **Oct. 31, 2007**

(51) **LOC (8) Cl.** ..... **16-03**

(52) **U.S. Cl.** ..... **D18/38**

(58) **Field of Classification Search** ..... D18/36-41,  
D18/44-56; 222/DIG. 1; 271/3.14, 8.1,  
271/226, 278; 355/97, 99; 358/1.1; 399/1-7,  
399/16, 75, 81, 107, 130, 151, 361, 365,  
399/367, 381-383, 388

See application file for complete search history.

(56) **References Cited**

**U.S. PATENT DOCUMENTS**

D312,267	S	*	11/1990	Biggs et al.	.....	D18/39
D344,973	S	*	3/1994	Penke et al.	.....	D18/39
D350,767	S	*	9/1994	Kojima et al.	.....	D18/38
5,481,353	A	*	1/1996	Hicks et al.	.....	399/382
6,259,866	B1	*	7/2001	Kabumoto et al.	.....	399/1
D450,082	S	*	11/2001	Kusanagi et al.	.....	D18/53

D453,943	S	*	2/2002	Sasaki	.....	D18/39
6,819,891	B2	*	11/2004	Suzuki	.....	399/81
D544,534	S	*	6/2007	Reece	.....	D18/53
D550,761	S	*	9/2007	Clark, III	.....	D18/39
D552,670	S	*	10/2007	Watanabe et al.	.....	D18/40

\* cited by examiner

*Primary Examiner*—Caron D. Veynar

*Assistant Examiner*—Garth Rademaker

(74) *Attorney, Agent, or Firm*—Dickstein Shapiro LLP

(57) **CLAIM**

The ornamental design for a dry electrostatic copying machine, as shown and described.

**DESCRIPTION**

FIG. 1 is a front elevation of a dry electrostatic copying machine according to the present invention;

FIG. 2 is a rear elevation thereof;

FIG. 3 is a top plan view thereof;

FIG. 4 is a bottom plan view thereof;

FIG. 5 is a right side elevation thereof;

FIG. 6 is a left side elevation thereof; and,

FIG. 7 is a top, front and right side perspective view thereof.

The broken lines depict environmental subject matter only and form no part of the claimed design.

**1 Claim, 6 Drawing Sheets**

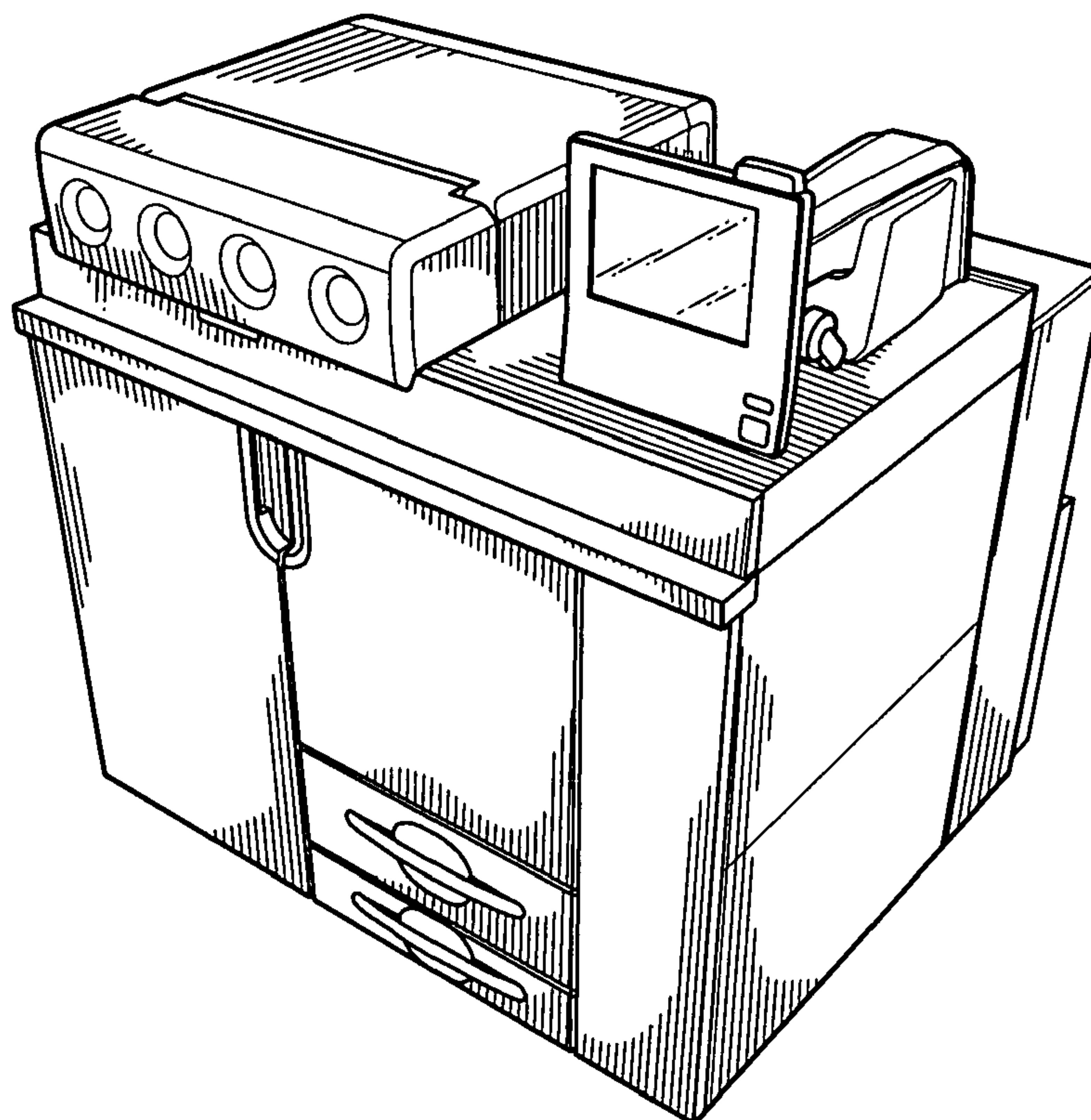

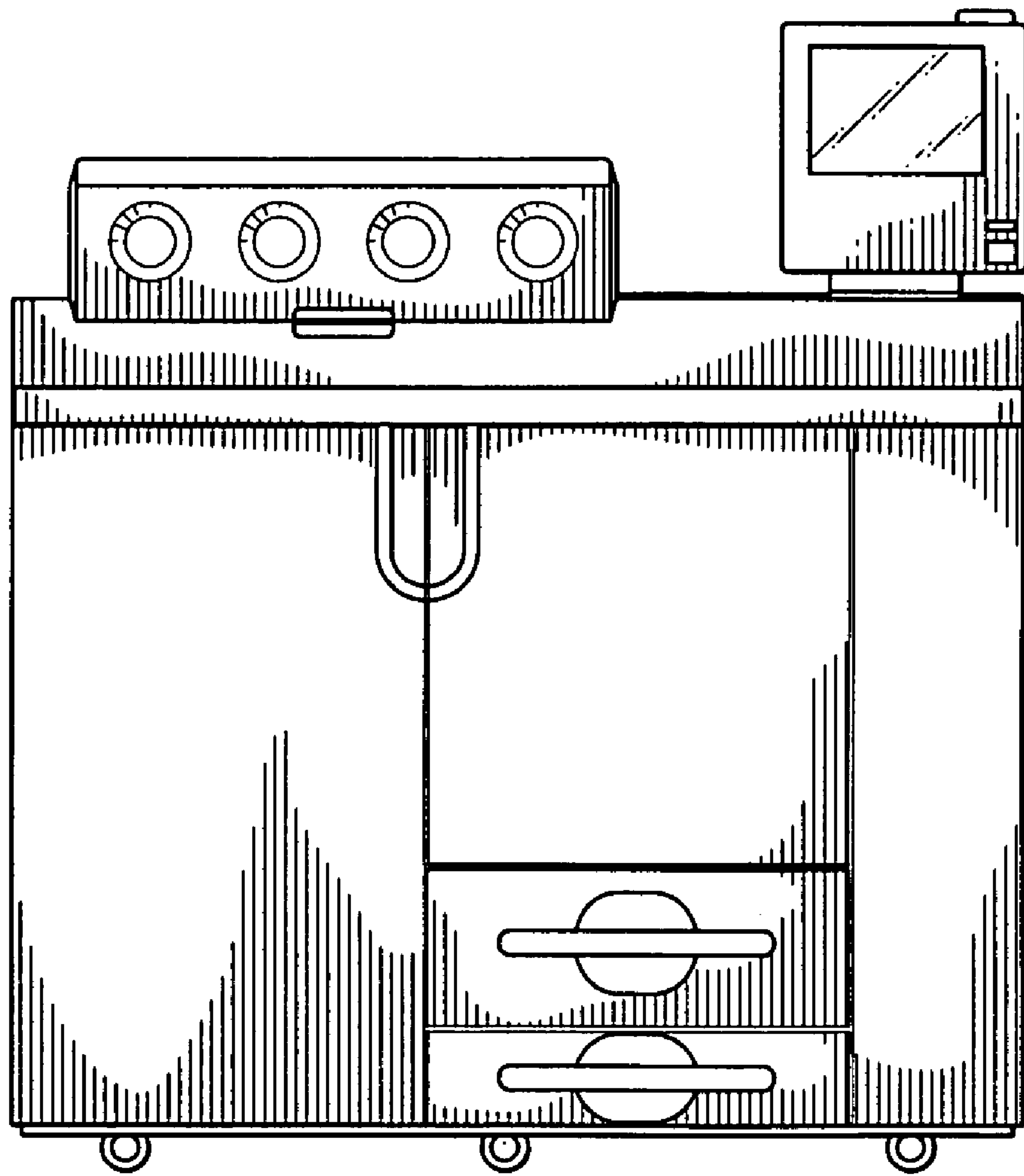

FIG. 1

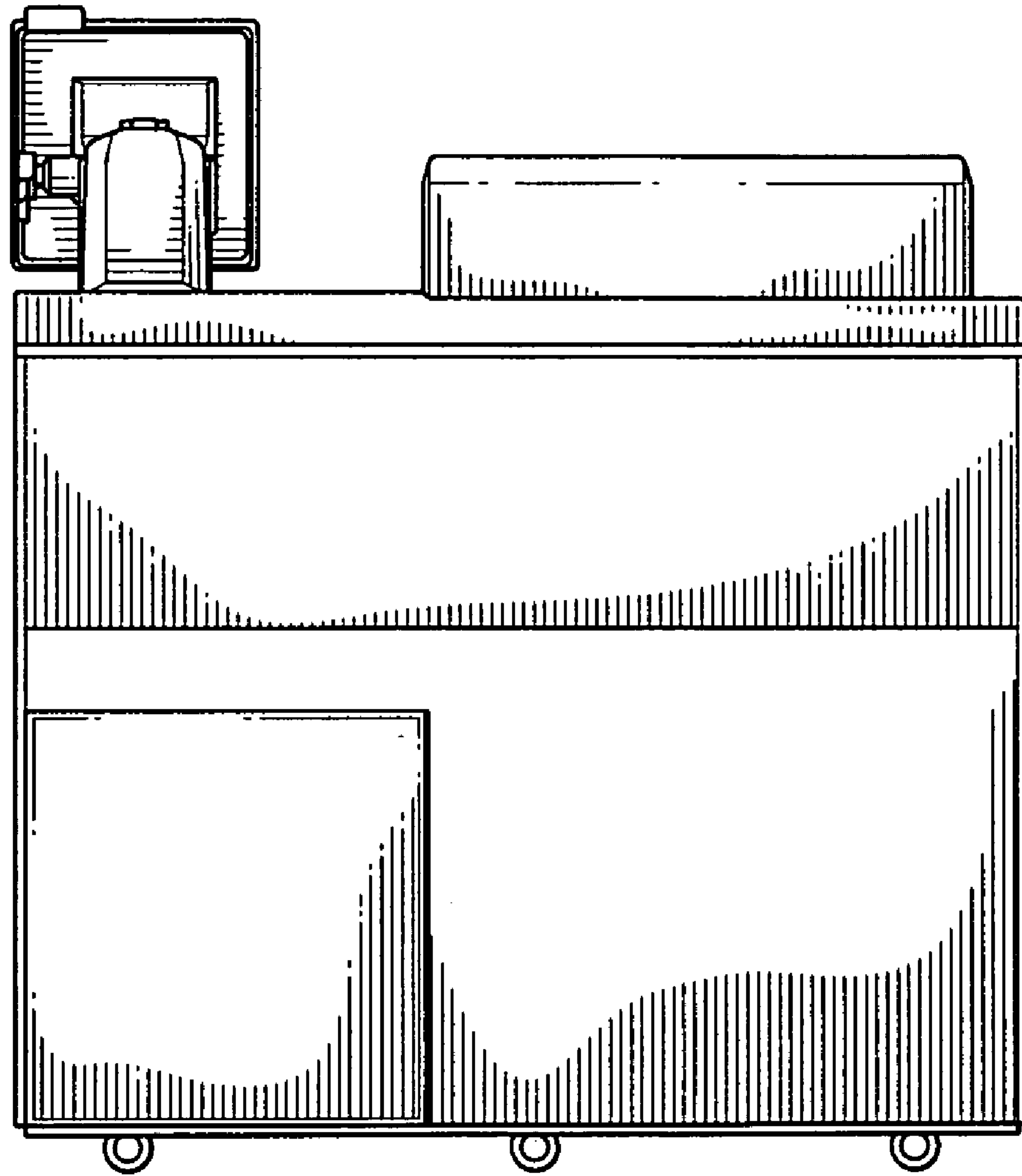

FIG. 2

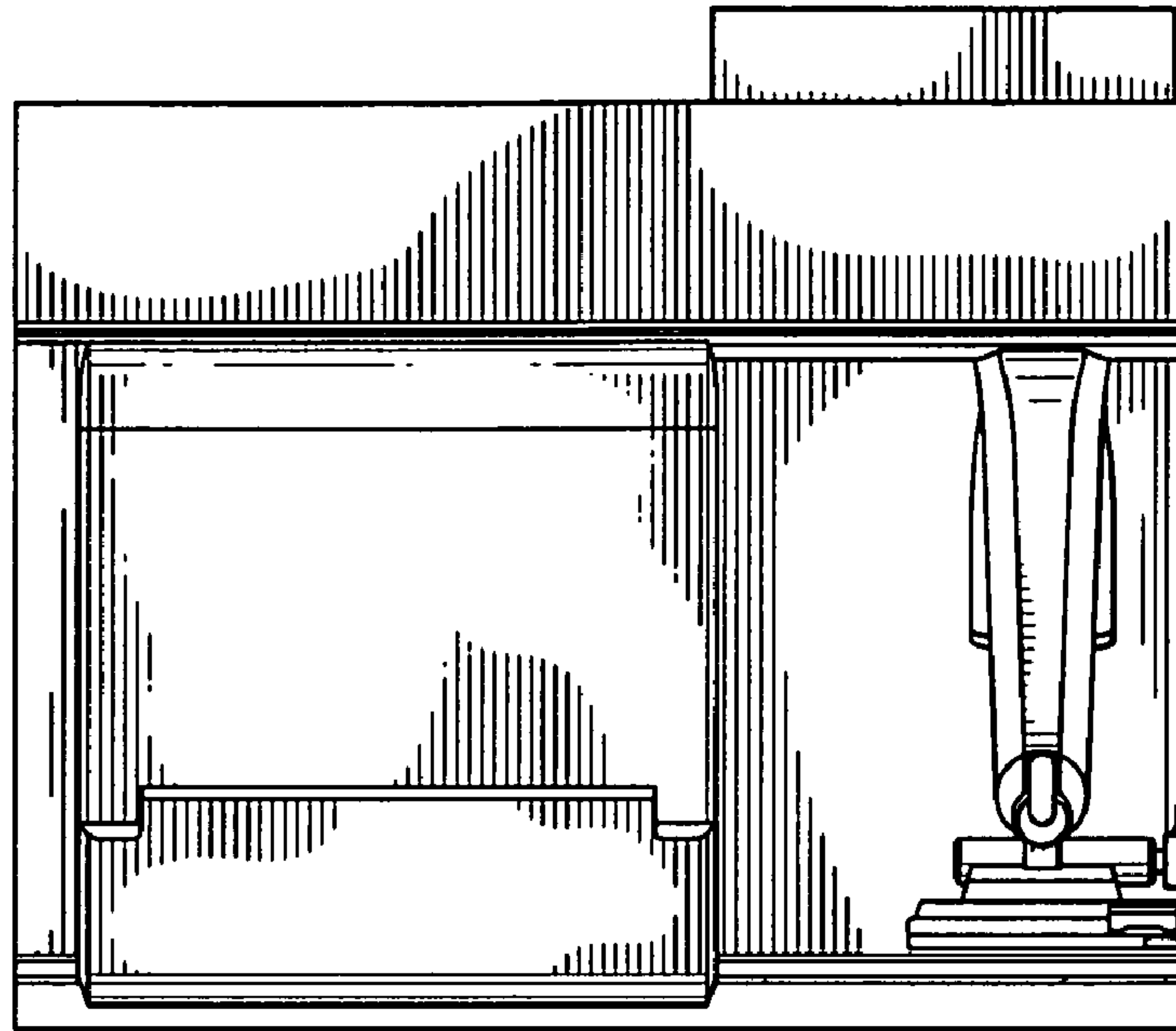

FIG. 3

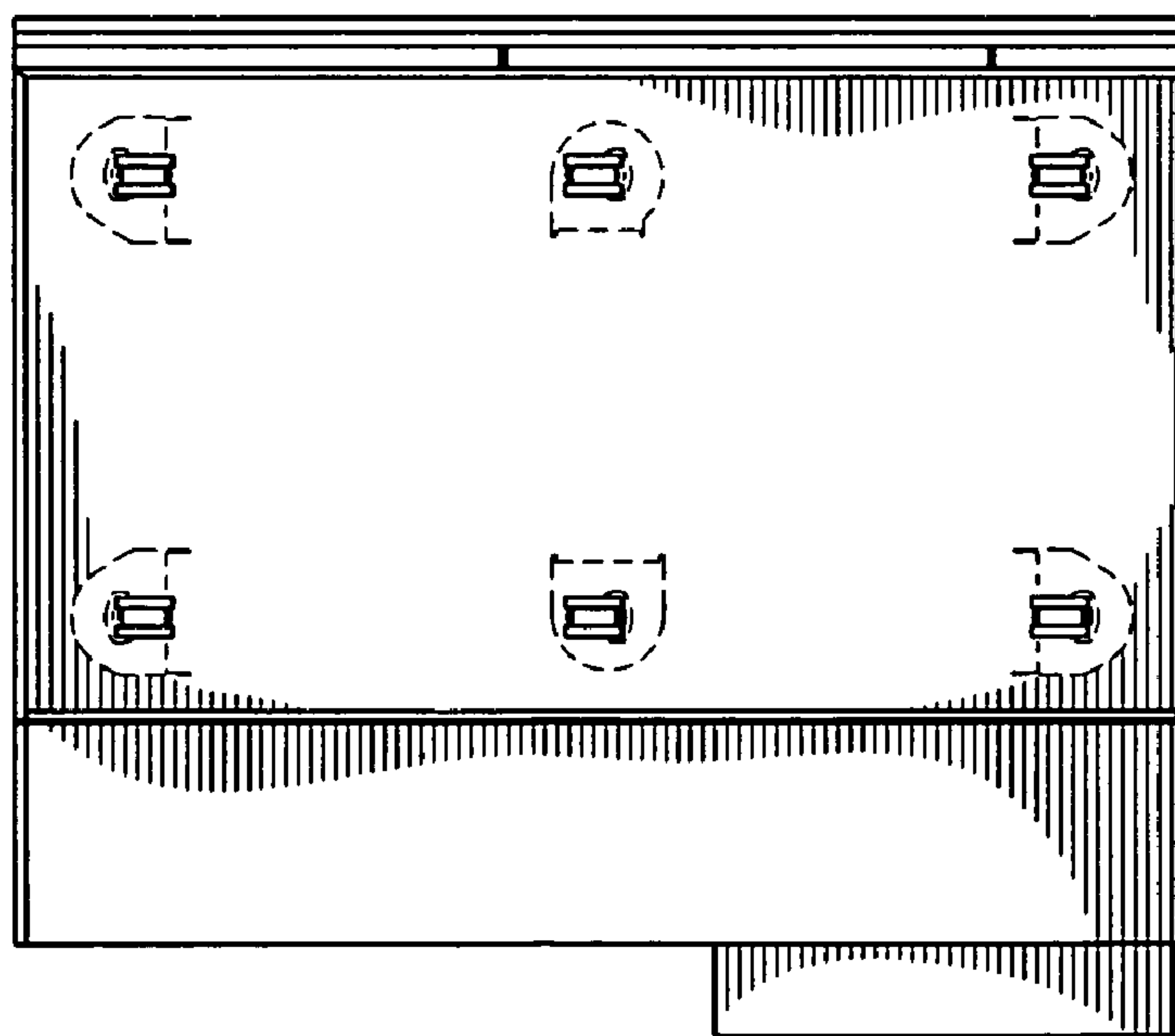

FIG. 4

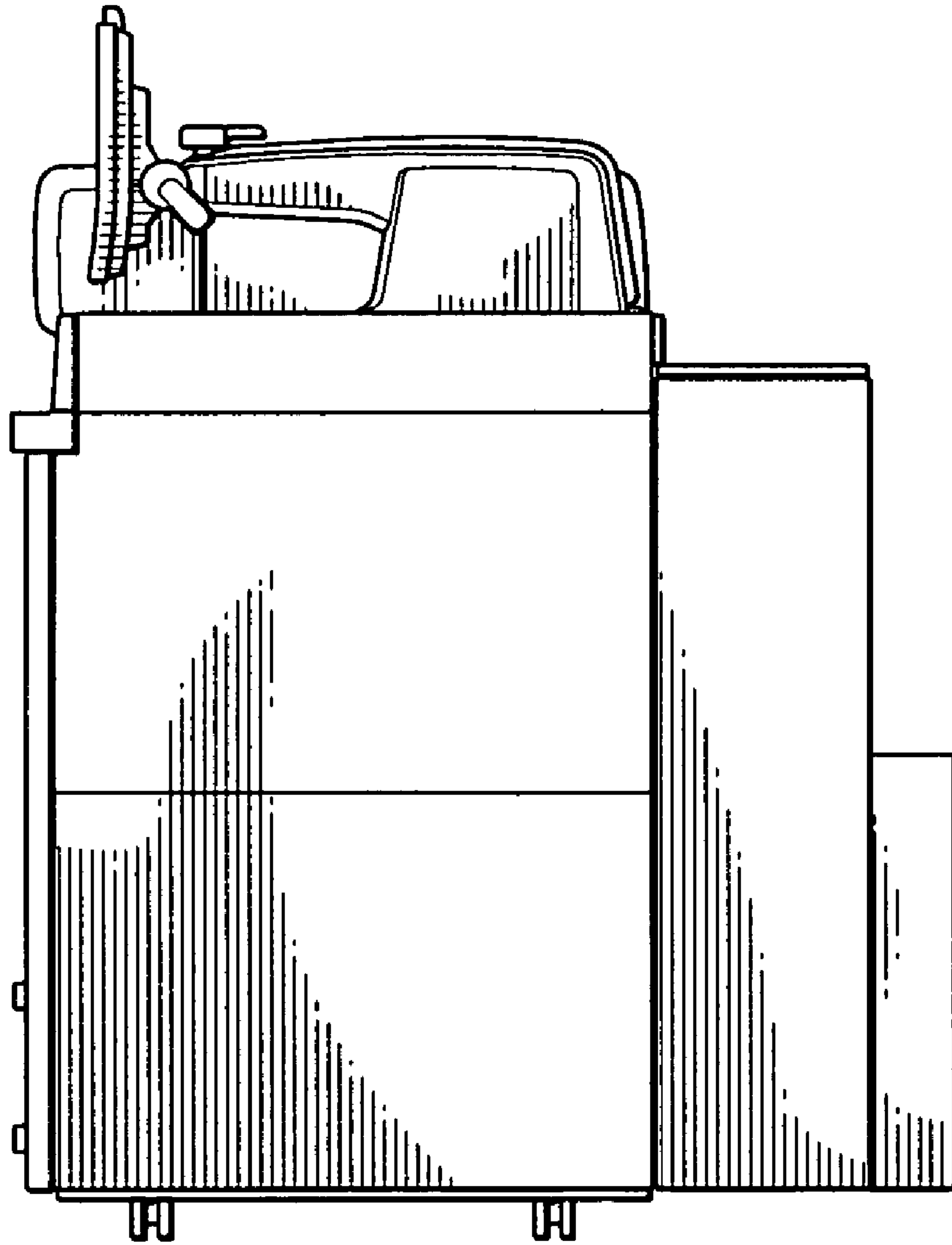

FIG. 5

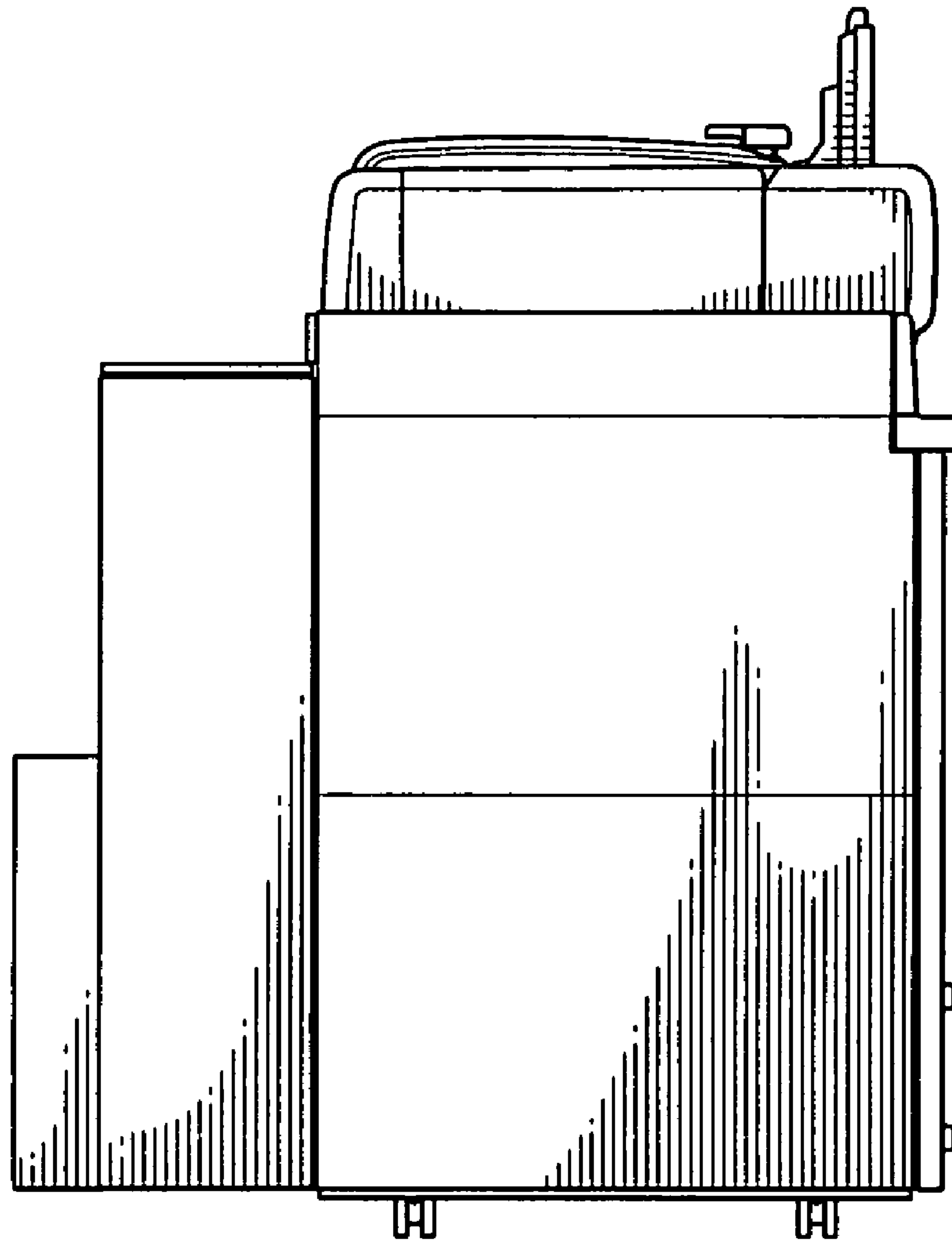

FIG. 6

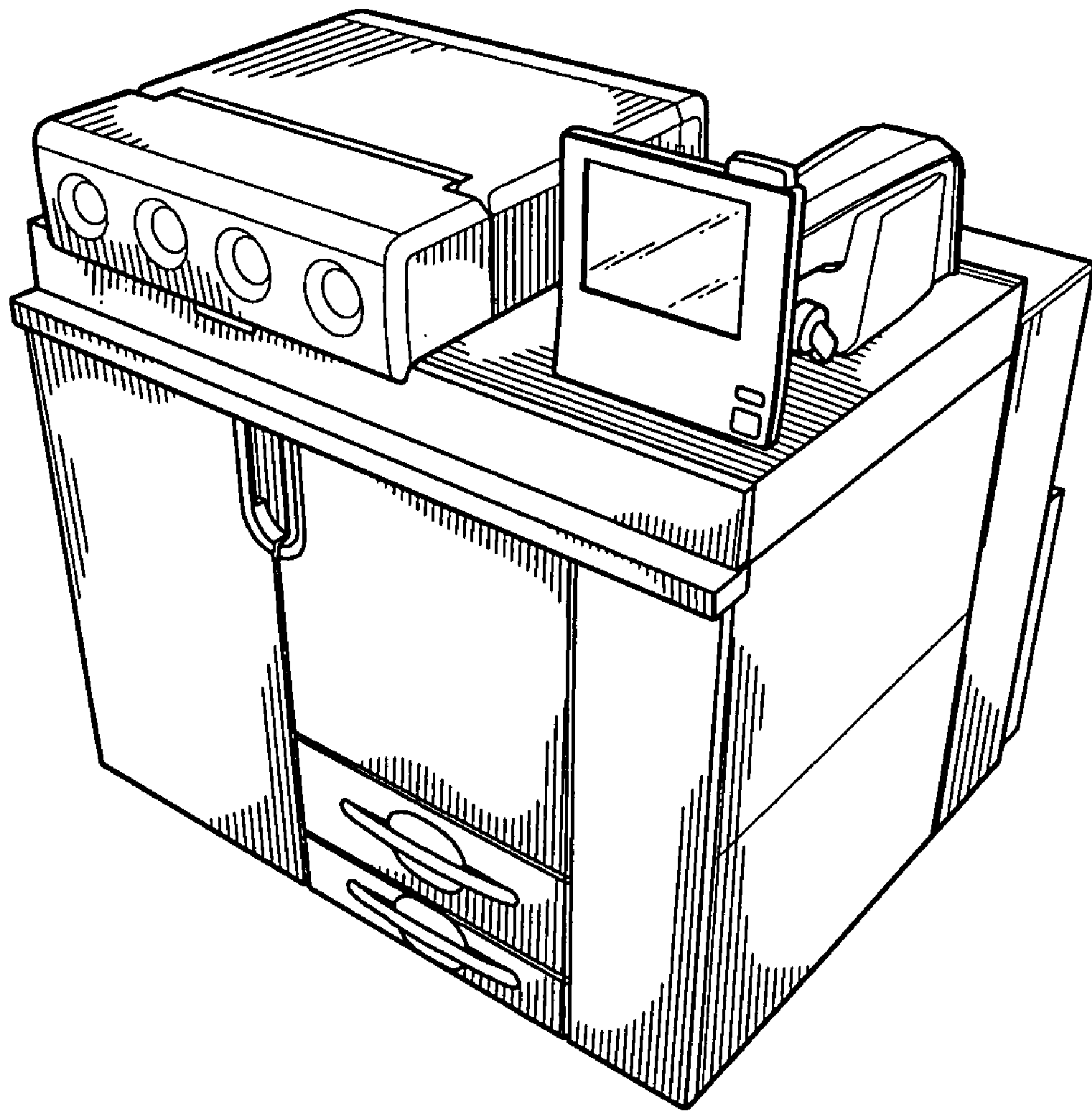

FIG. 7