



US00D580410S

(12) **United States Design Patent**
Omori et al.

(10) **Patent No.:** **US D580,410 S**
(45) **Date of Patent:** **** Nov. 11, 2008**

(54) **SPEAKER BOX**

(75) Inventors: **Tatsuya Omori**, Kadoma (JP); **Takashi Suzuki**, Kadoma (JP)

(73) Assignee: **Panasonic Corporation**, Osaka (JP)

(**) Term: **14 Years**

(21) Appl. No.: **29/302,910**

(22) Filed: **Jan. 28, 2008**

(30) **Foreign Application Priority Data**

Oct. 2, 2007 (JP) 2007-026925

(51) **LOC (8) Cl.** **14-01**

(52) **U.S. Cl.** **D14/215**

(58) **Field of Classification Search** D14/204,
D14/207, 209–216; 181/143–144, 147–148,
181/150, 157, 198–199, 151, 153; 381/300–302,
381/306, 333, 345, 361–364, 386–388, 332,
381/336

See application file for complete search history.

(56) **References Cited**

U.S. PATENT DOCUMENTS

D416,020 S *	11/1999	Warren	D14/214
D485,258 S *	1/2004	Allen	D14/215
D485,259 S *	1/2004	Allen	D14/215
D486,143 S *	2/2004	Allen	D14/215
D486,474 S *	2/2004	Allen	D14/215
D518,025 S *	3/2006	Omori et al.	D14/211

FOREIGN PATENT DOCUMENTS

JP	D1110001	5/2001
JP	D1223857	11/2004
JP	D1223904	11/2004

OTHER PUBLICATIONS

Japanese Office Action issued Mar. 4, 2008 in Japanese Design application No. 2007-026925 (with translation).
“B&W CDM1NT” Hivi No. 8, p. 106, Aug. 20, 2001 (JPO Design Reference No. HA13010378 received on Jul. 19, 2001).

* cited by examiner

Primary Examiner—Nanda Bondade

(74) *Attorney, Agent, or Firm*—Brinks Hofer Gilson & Lione

(57) **CLAIM**

We claim the ornamental design for a speaker box, as shown and described.

DESCRIPTION

FIG. 1 is a front perspective view of a speaker box of the present invention;

FIG. 2 is a rear perspective view thereof;

FIG. 3 is a front view thereof;

FIG. 4 is a rear view thereof;

FIG. 5 is a first side view thereof;

FIG. 6 is a second side view thereof;

FIG. 7 is a top view thereof; and,

FIG. 8 is a bottom view thereof.

1 Claim, 8 Drawing Sheets

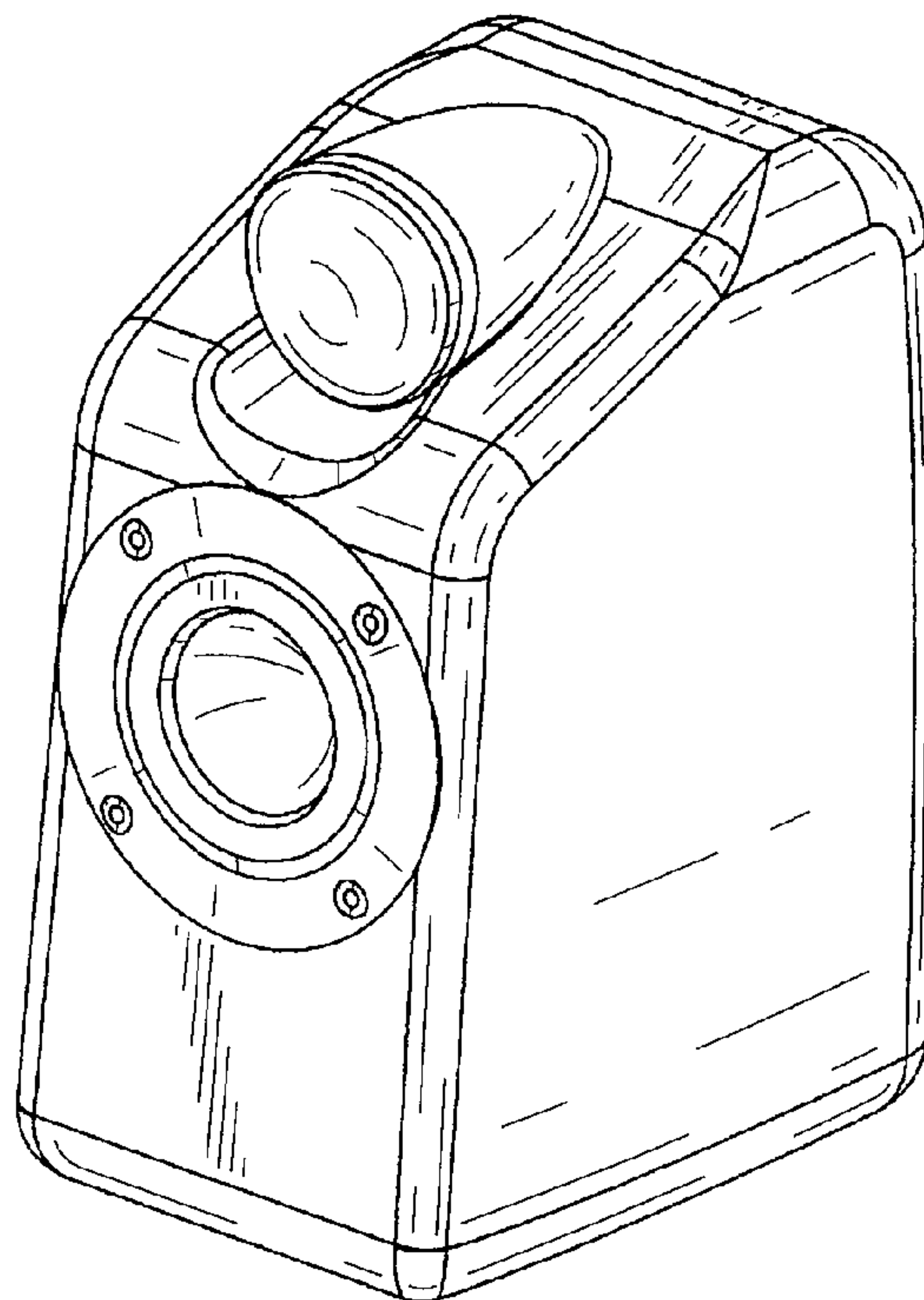

FIG. 1

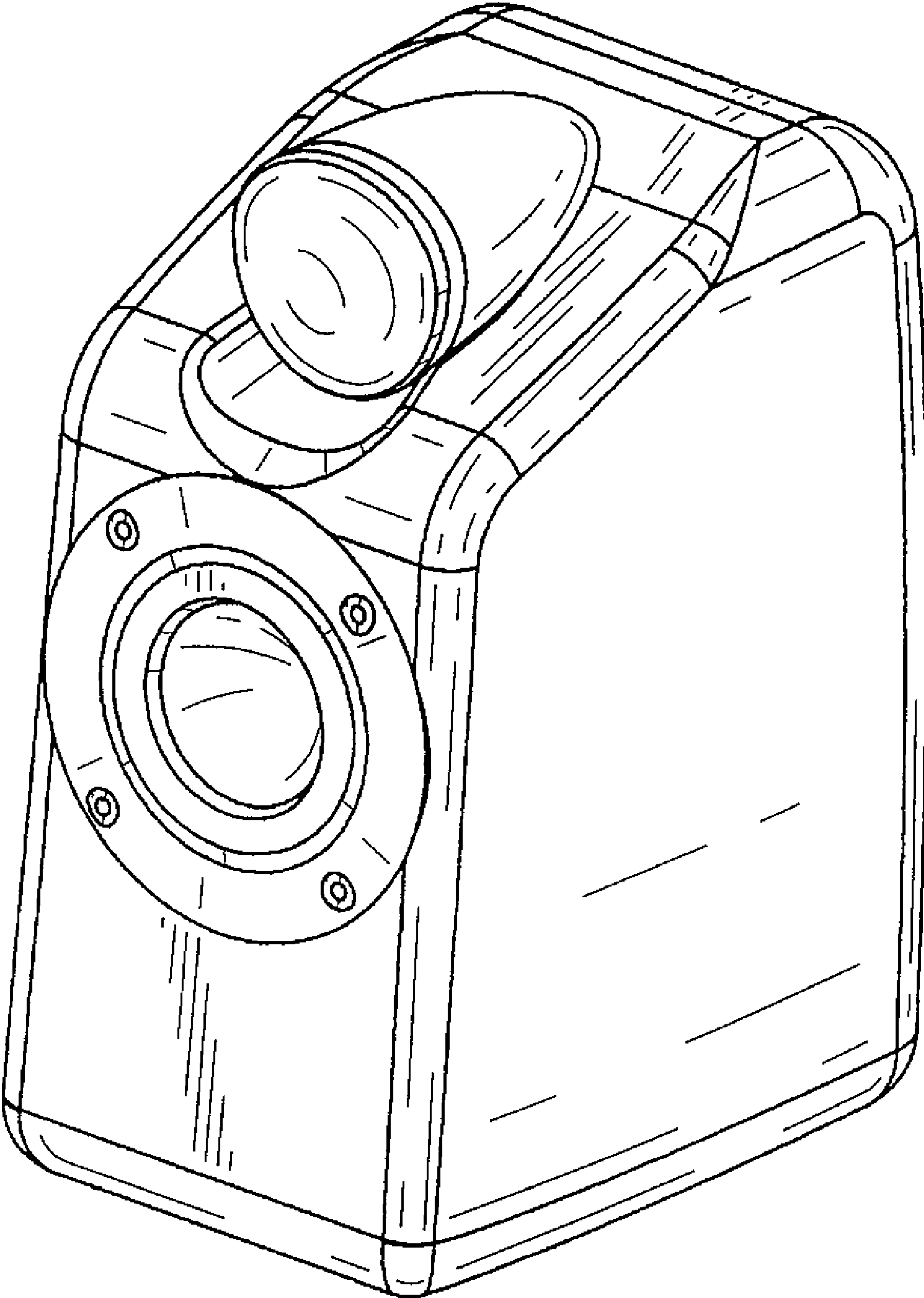

FIG.2



FIG.3

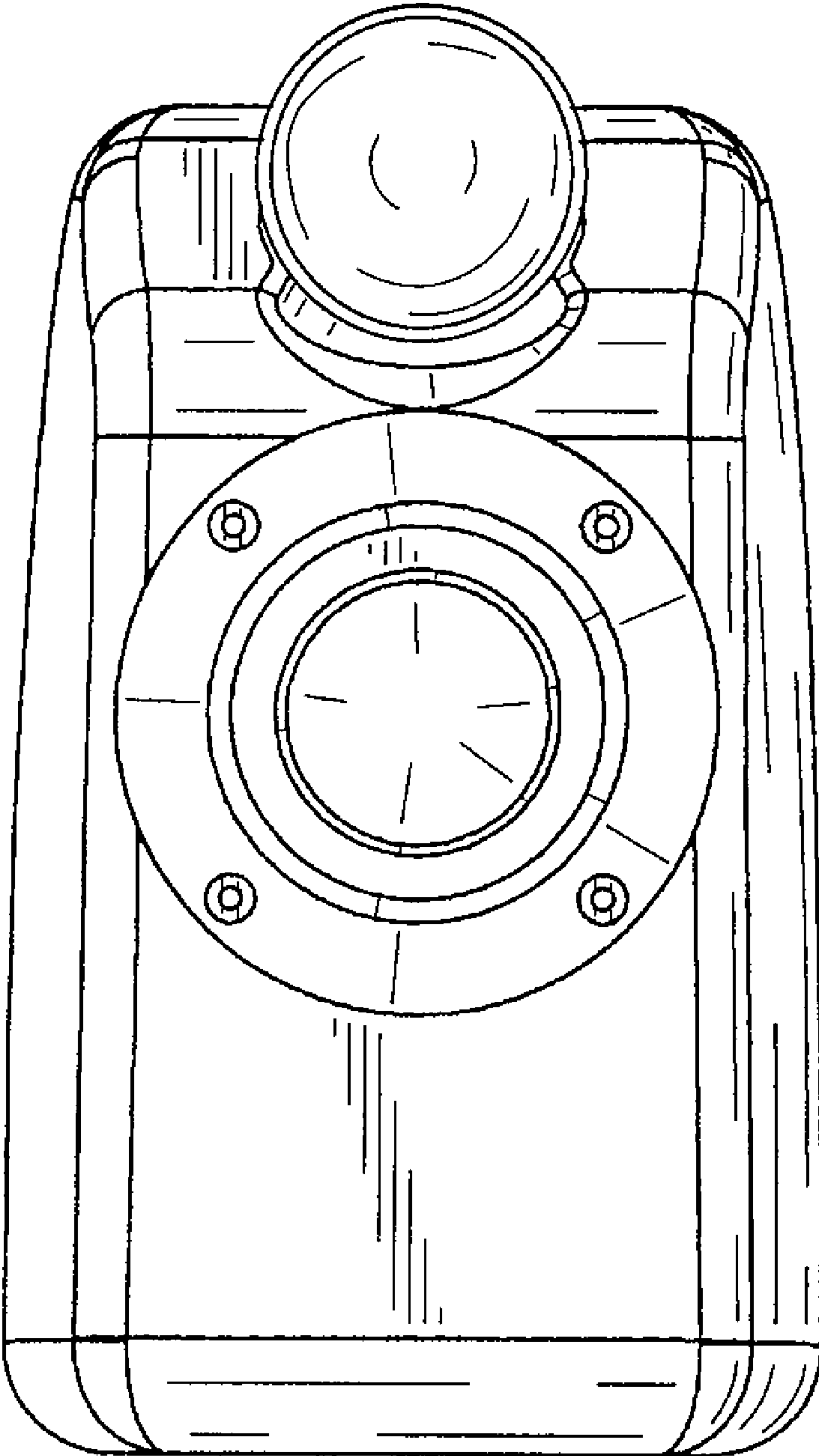

FIG. 4

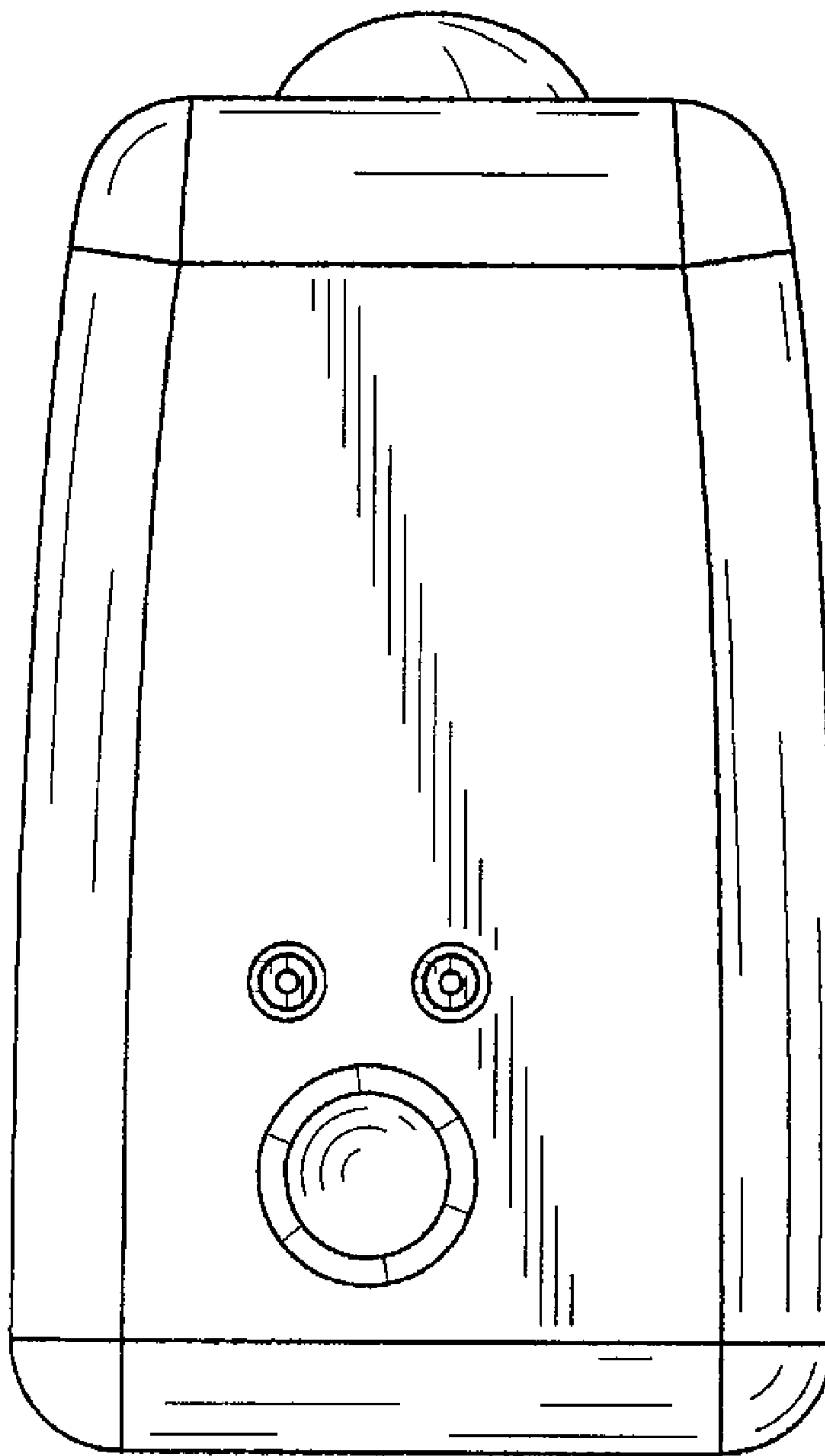

FIG.5

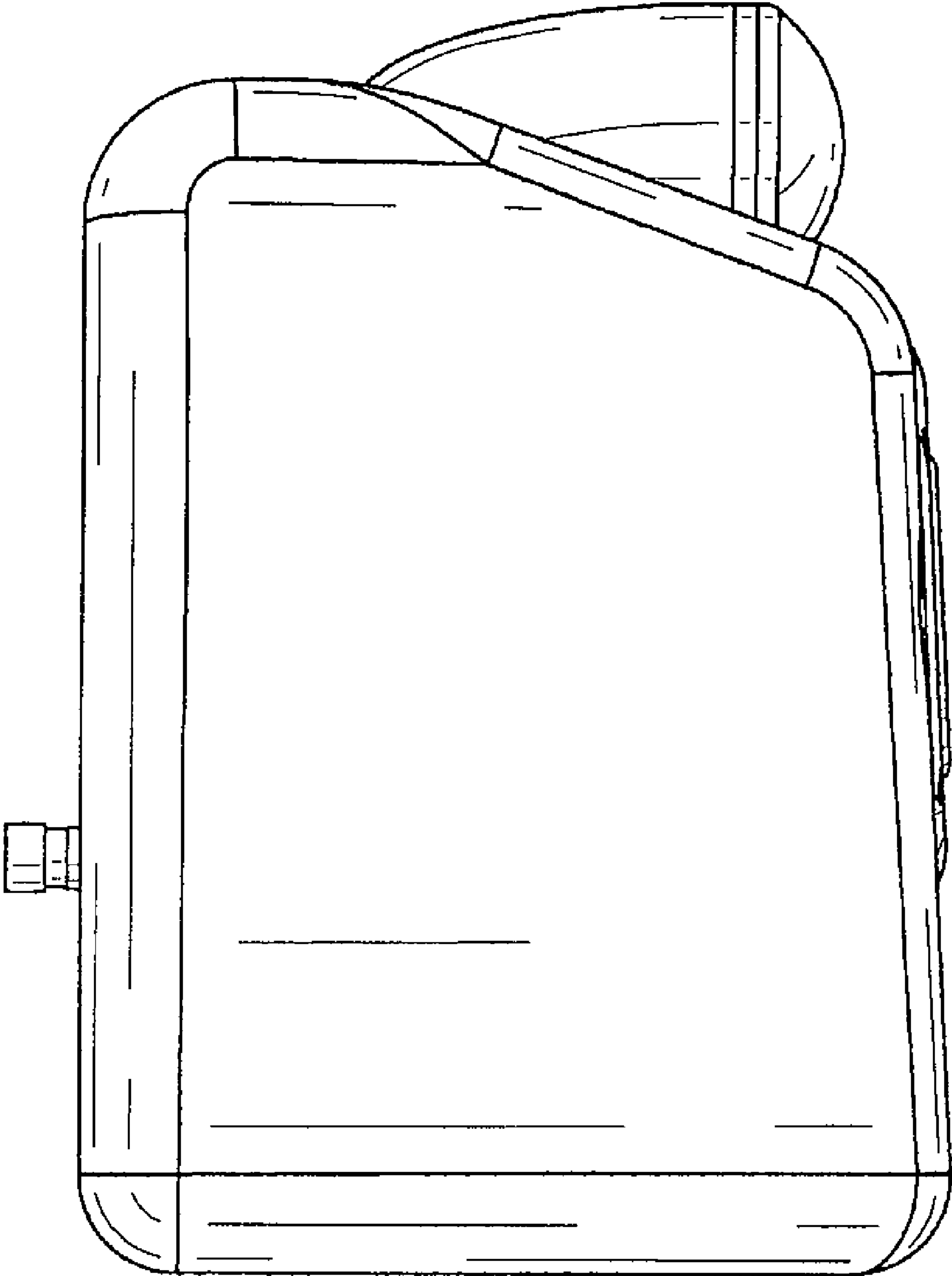

FIG. 6

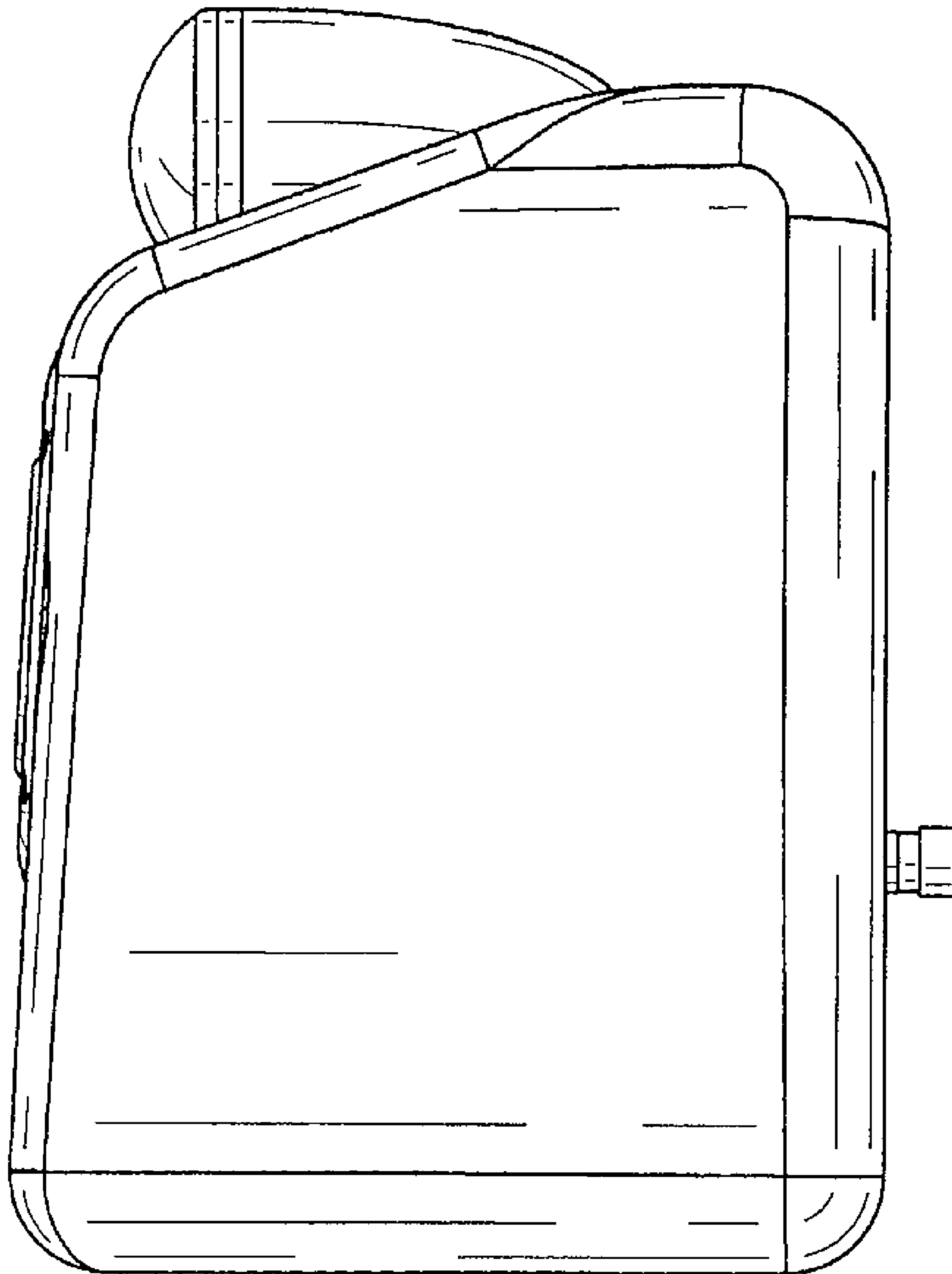

FIG. 7

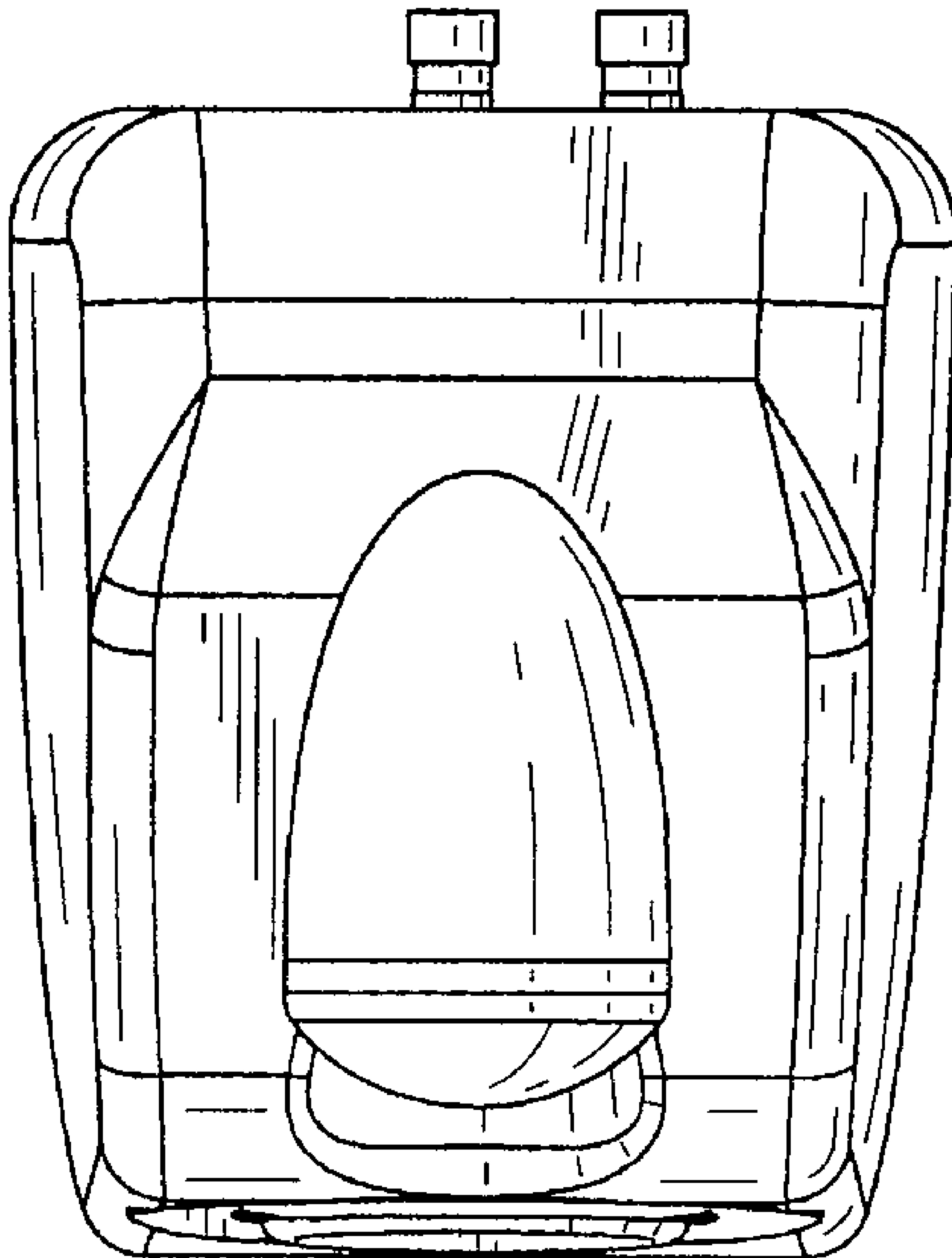

FIG. 8

