



US00D580344S

(12) **United States Design Patent**  
**Wai**

(10) **Patent No.:** **US D580,344 S**  
(45) **Date of Patent:** **\*\* Nov. 11, 2008**

(54) **HELICOPTER ROTORS, BLADES AND SHAFTS**

(75) Inventor: **Chi Pok Billy Wai**, Quarry Bay (HK)

(73) Assignee: **Silverlit Toys Manufactory, Ltd.**, Hong Kong (HK)

(\*\*) Term: **14 Years**

(21) Appl. No.: **29/303,199**

(22) Filed: **Feb. 1, 2008**

**Related U.S. Application Data**

(63) Continuation-in-part of application No. 29/282,291, filed on Jul. 16, 2007, now Pat. No. Des. 561,676, which is a continuation-in-part of application No. 29/275,322, filed on Dec. 20, 2006, now Pat. No. Des. 546,269, and a continuation-in-part of application No. 29/275,323, filed on Dec. 20, 2006, now Pat. No. Des. 544,825, and a continuation-in-part of application No. 29/275,324, filed on Dec. 20, 2006, now Pat. No. Des. 545,755, and a continuation-in-part of application No. 29/277,652, filed on Mar. 5, 2007, now Pat. No. Des. 552,531, and a continuation-in-part of application No. 29/280,187, filed on May 18, 2007, now Pat. No. Des. 554,040, said application No. 29/275,322 and a continuation-in-part of application No. 11/465,781, filed on Aug. 18, 2006, is a continuation-in-part of application No. 11/462,177, filed on Aug. 3, 2006.

(51) **LOC (8) Cl.** ..... **12-07**

(52) **U.S. Cl.** ..... **D12/345**

(58) **Field of Classification Search** ..... D12/326-329, D12/345; D21/441-442, 450, 453; 446/36-45, 446/230, 232; 244/17.11, 17.23, 17.25, 17.19, 244/17.27, 12.4

See application file for complete search history.

(56) **References Cited**

**U.S. PATENT DOCUMENTS**

1,403,909 A 1/1922 Moir

(Continued)

**FOREIGN PATENT DOCUMENTS**

BE 338599 12/1926

(Continued)

**OTHER PUBLICATIONS**

U.S. Appl. No. 11/953,823, filed Dec. 10, 2007, Van de Rostyne.

(Continued)

*Primary Examiner*—Ian Simmons

*Assistant Examiner*—Maurice Stevens

(74) *Attorney, Agent, or Firm*—Greenberg Traurig, LLP

(57) **CLAIM**

The ornamental design for a helicopter rotors, blades and shafts, as shown and described.

**DESCRIPTION**

FIG. 1 is a front, right side view of a helicopter rotors, blades and shafts, showing our new design;

FIG. 2 is a rear, left side view thereof;

FIG. 3 is a right, rear side view thereof;

FIG. 4 is a top, left side view thereof;

FIG. 5 is a left side view thereof; and,

FIG. 6 is a right side view thereof.

Broken lines are for illustrative purposes only and form no part of the claimed design.

**1 Claim, 6 Drawing Sheets**

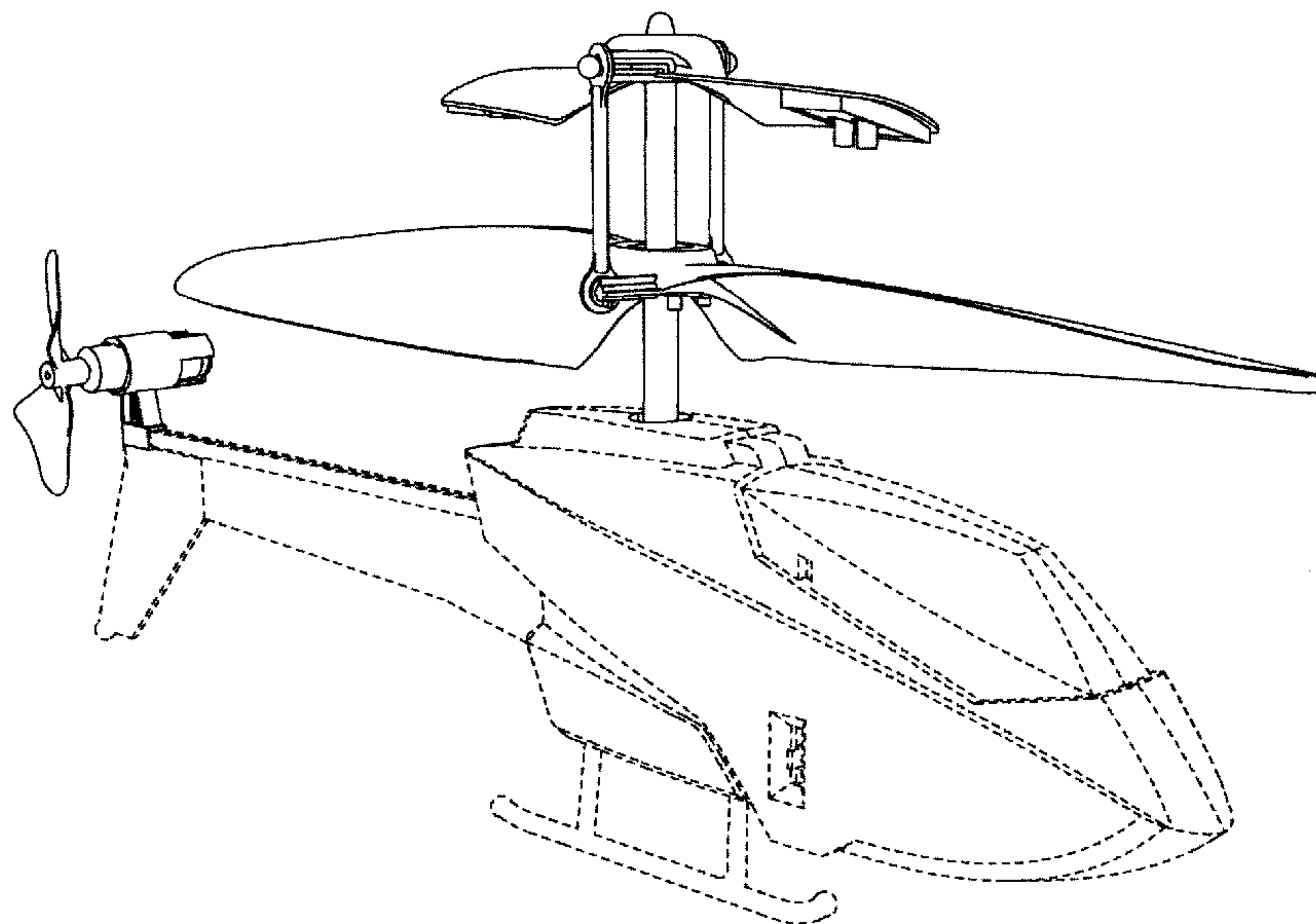

# US D580,344 S

U.S. PATENT DOCUMENTS							
1,446,522	A *	2/1923	Smith ..... 416/123	5,628,620	A	5/1997	Arlton
1,773,281	A	8/1930	Scott	D388,048	S	12/1997	Taylor et al.
1,800,470	A	4/1931	Oehmichen	D390,942	S	2/1998	Mei
2,030,578	A	2/1936	Flettner	5,749,540	A	5/1998	Arlton
2,368,698	A	2/1945	Young	5,836,545	A	11/1998	Arlton et al.
2,384,516	A	9/1945	Young	5,879,131	A	3/1999	Arlton et al.
2,411,596	A	11/1946	Shapiro	5,906,476	A	5/1999	Arlton
2,413,831	A	1/1947	Jordan	6,000,911	A	12/1999	Toulmay et al.
2,429,502	A	10/1947	Young	D421,279	S	2/2000	Tsai
D149,130	S	3/1948	Katenberter et al.	6,032,899	A	3/2000	Mondet et al.
2,439,143	A	4/1948	Nemeth	6,039,541	A	3/2000	Parker et al.
D153,314	S	4/1949	Piasecki	D425,853	S	5/2000	Caporaletti
D153,315	S	4/1949	Piasecki	6,302,652	B1	10/2001	Roberts
D153,316	S	4/1949	Piasecki	6,398,618	B1	6/2002	Wu
D153,317	S	4/1949	Piasecki	6,435,453	B1 *	8/2002	Carter, Jr. .... 244/8
2,469,144	A	5/1949	Baggott	6,460,802	B1	10/2002	Norris
2,481,750	A	9/1949	Hiller, Jr. et al.	6,467,726	B1	10/2002	Hosoda
2,486,059	A *	10/1949	Pentecost ..... 416/115	D467,861	S	12/2002	Lee
2,532,683	A	12/1950	Traver	6,499,690	B1	12/2002	Katayama et al.
D163,938	S	7/1951	Douglas	6,543,726	B2	4/2003	Illingworth
2,629,568	A	2/1953	Croshere, Jr. et al.	6,632,119	B2	10/2003	Cherneck et al.
2,633,924	A	4/1953	Young	6,659,395	B2	12/2003	Rehkemper et al.
2,646,848	A	7/1953	Young	6,659,721	B1	12/2003	Parker et al.
2,629,570	A	12/1953	Carnahan	6,719,244	B1	4/2004	Gress
D171,569	S	3/1954	Apostolescu	6,732,973	B1	5/2004	Rehkemper
2,725,494	A	11/1955	Anderson	6,749,401	B2	6/2004	Vanmoor
D178,081	S	6/1956	Papadakos	6,758,436	B2	7/2004	Rehkemper et al.
2,750,131	A	6/1956	Thomson	6,789,764	B2	9/2004	Bass et al.
D181,643	S	12/1957	Graham	6,884,034	B1	4/2005	Parker et al.
D187,895	S	5/1960	Douglas	6,886,777	B2	5/2005	Rock
2,950,074	A	8/1960	Apostolescu	6,929,215	B2	8/2005	Arlton
3,029,048	A	4/1962	Brooks et al.	D524,227	S *	7/2006	Stille et al. .... D12/327
3,035,643	A	5/1962	Kelley et al.	D524,228	S *	7/2006	Scott et al. .... D12/327
3,080,001	A	3/1963	Culver et al.	D524,229	S	7/2006	Stille et al.
3,093,929	A	6/1963	Robbins et al.	D524,718	S *	7/2006	Scott et al. .... D12/327
3,106,964	A	10/1963	Culver et al.	7,100,866	B2	9/2006	Rehkemper et al.
3,180,424	A	4/1965	Serriades	7,178,758	B2 *	2/2007	Rehkemper ..... 244/17.11
3,213,944	A	10/1965	Nichols et al.	7,198,223	B2	4/2007	Phelps, III et al.
3,228,478	A	1/1966	Edenborough	D544,825	S	6/2007	Van de Rostyne et al.
3,409,249	A	11/1968	Bergquist et al.	D545,735	S *	7/2007	Angelo et al. .... D12/173
3,448,810	A	6/1969	Vogt	D545,755	S	7/2007	Van de Rostyne et al.
3,572,616	A	3/1971	Ulisnik	D546,269	S	7/2007	Van de Rostyne et al.
3,592,559	A	7/1971	Ward	D548,803	S	8/2007	Zimet
3,625,631	A	12/1971	Covington, Jr. et al.	7,264,199	B2	9/2007	Zientek
3,771,924	A	11/1973	Buchstaller	D552,531	S	10/2007	Van de Rostyne et al.
D232,168	S	7/1974	Leoni	D554,040	S	10/2007	Van de Rostyne et al.
D232,170	S	7/1974	Diamond et al.	2002/0109044	A1	8/2002	Rock
D234,350	S	2/1975	Beckert et al.	2002/0134883	A1	9/2002	Stamps et al.
D239,930	S	5/1976	Ulisnik	2004/0087241	A1	5/2004	Agostini et al.
4,025,230	A	5/1977	Kastan	2004/0184915	A1	9/2004	Kunii et al.
4,053,123	A	10/1977	Chadwick	2004/0222329	A1	11/2004	Kuhns et al.
4,073,086	A	2/1978	Ogawa	2004/0245376	A1	12/2004	Muren
4,118,143	A	10/1978	Kavan	2005/0121553	A1	6/2005	Isawa et al.
4,142,697	A	3/1979	Fradenburgh	2006/0121819	A1	6/2006	Isawa
D253,003	S	9/1979	Tanaka	2006/0231677	A1	10/2006	Zimet et al.
4,227,856	A	10/1980	Verrill et al.	2007/0012818	A1	1/2007	Miyazawa et al.
4,307,533	A	12/1981	Sims et al.	2007/0105475	A1	5/2007	Gotou et al.
4,522,563	A	6/1985	Reyes et al.	2007/0164148	A1	7/2007	Van de Rostyne
4,629,440	A	12/1986	Mckittrick et al.	2007/0164149	A1	7/2007	Van de Rostyne
D294,605	S	3/1988	Matsumoto	2007/0164150	A1	7/2007	Van de Rostyne
5,015,187	A	5/1991	Lord	2007/0178798	A1	8/2007	Lai
5,108,043	A *	4/1992	Canavespe ..... 244/17.11	2007/0181742	A1	8/2007	Van de Rostyne et al.
5,209,429	A *	5/1993	Doolin et al. .... 244/17.11	2007/0187549	A1	8/2007	Owen
5,240,204	A	8/1993	Kunz	2007/0215750	A1	9/2007	Shantz et al.
5,255,871	A	10/1993	Ikeda	2007/0221781	A1	9/2007	Van de Rostyne
5,370,341	A *	12/1994	Leon ..... 244/17.11	2007/0272794	A1	11/2007	Van de Rostyne
D357,894	S	5/1995	Arnold et al.	FOREIGN PATENT DOCUMENTS			
5,511,947	A	4/1996	Schmuck	BE	1016960	11/2007	
D372,741	S	8/1996	Tsai	DE	1 270 408	6/1968	
D378,606	S	3/1997	Tamagnini	DE	40 17 402 A1	12/1991	
5,609,312	A	3/1997	Arlton et al.	DE	94 14 652 U1	11/1994	



GB	916894 A	1/1963
GB	956536	4/1964
GB	958536	5/1964
GB	1081341 A	8/1967
JP	1269699	10/1989
JP	30-7668	1/1991
JP	32-003535	9/1991
JP	9048398	2/1997
JP	9512515	12/1997
JP	10076996	3/1998
JP	2000-272594	10/2000
JP	2003-103066	4/2003
JP	2003-220999	8/2003
JP	2004-121798	4/2004
JP	2005-193905	7/2005
JP	2006-051217	2/2006

OTHER PUBLICATIONS

U.S. Appl. No. 11/953,826, filed Dec. 10, 2007, Van de Rostyne.  
 U.S. Appl. No. 11/953,830, filed Dec. 10, 2007, Van de Rostyne.  
 U.S. Appl. No. 29/282,581, filed Jul. 24, 2007, Van de Rostyne, et al.  
 U.S. Appl. No. 29/283,934, filed Aug. 27, 2007, Van de Rostyne, et al.  
 U.S. Appl. No. 29/297,478, filed Nov. 12, 2007, Van de Rostyne, et al.  
 U.S. Appl. No. 29/297,479, filed Nov. 12, 2007, Van de Rostyne, et al.  
 U.S. Appl. No. 29/297,765, filed Nov. 16, 2007, Van de Rostyne, et al.  
 U.S. Appl. No. 29/302,018, filed Jan. 8, 2008, Van de Rostyne, et al.  
 U.S. Appl. No. 29/302,020, filed Jan. 8, 2008, Van de Rostyne, et al.  
 Photographic prior art reference #1, helicopter.  
 Photographic prior art reference #2, helicopter displaying writing in French on the tail.  
 Photographic prior art reference #3, explanation of the function of the flybar.  
 Photographic prior art reference #4, toy helicopter, www.raidentech.com.  
 Photographic prior art reference #5, toy helicopter.  
 Photographic prior art reference #6, helicopter.  
 Photographic prior art reference #7, helicopter with M40297 or MA0297 displayed on the tail.

Photographic prior art reference #8, toy helicopter #AHS-23900, hstoy.en.alibaba.com.  
 Photographic prior art reference #9, toy helicopter, toys999.en.alibaba.com.  
 Mill, Colin. "Practical Theories, Part 9", W3MH—World Wide Web *Model Helicopter Magazine*, Jul. 1996, <http://www.w3mh.co.uk/articles/html/csm9-11.htm>.  
 Day, David. "Moving swashplates & CCPM", 2001-2006. See <http://www.iroquois.free-online.co.uk>.  
 Selberg, B.P.; Cronin, D.L.; Rokhsaz, K.; Dykman, J.R., Yager, C. J. "Aerodynamic-Structural Analysis of Dual Bladed Helicopter Systems (Field Technical Report)", Report No. NASA-CR-162754, Feb. 1980 46p (Abstract).  
 Ham, Normand. Helicopter individual-blade-control research at MIT 1977-1985; DGLR, European Rotorcraft Forum, 12th, Garmisch-Partenkirchen, West Germany; Germany, Federal Republic of; Sep. 22-25, 1986 10 pp. 1986 (Abstract).  
 Proctor, Paul. "Aviation Week & Space Technology", v146, n13, p. 47(1), Mar. 31, 1997 (Abstract).  
 Zein-Sabatto, S.; Zheng, Y. "Intelligent Flight Controllers for Helicopter Control"; 1997 IEEE International Conference on Neural Networks, Proceedings (Cat. No. 97CH36109) Part vol. 2 p. 617-21 vol. 2 (Abstract).  
 Mirick, Paul H. "A Comparison of Theory and Experiment for Coupled Rotor Body Stability of a Bearingless Rotor Model in Hover and Forward Flight", Jun. 1, 1988, IP Document Id 19880017770 pp. 87-101 (Abstract).  
 US District Court, Eastern District of Virginia, Norfolk Division, *Silverlit Toys Manufactory, Ltd., et al. v. Westminster, Inc., et al.*, Case No. 2:07-cv-472-JBF/JEB.  
 US District Court, Northern District of Georgia, Atlanta Division, *Westminster, Inc. v. Silverlit Toys Manufactory, Ltd., et al.*, Case No. 1:07-cv-2450-JOF.  
 US District Court, Central District of California, Southern Division, *Innovage LLC v. Silverlit Toys Manufactory, Ltd., et al.*, Case No. SACV07-1334 DOC (ANx).

\* cited by examiner

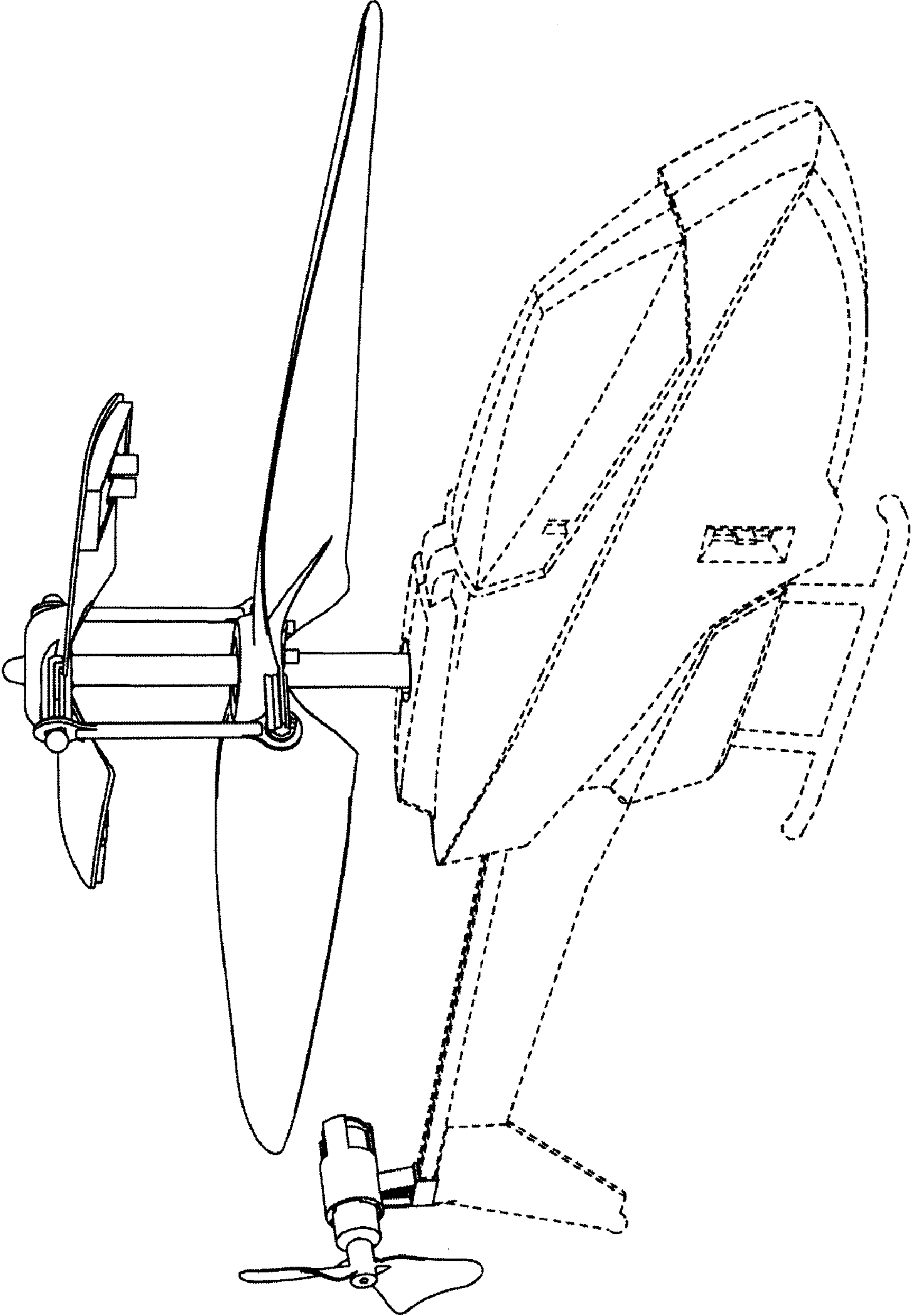

Fig. 1

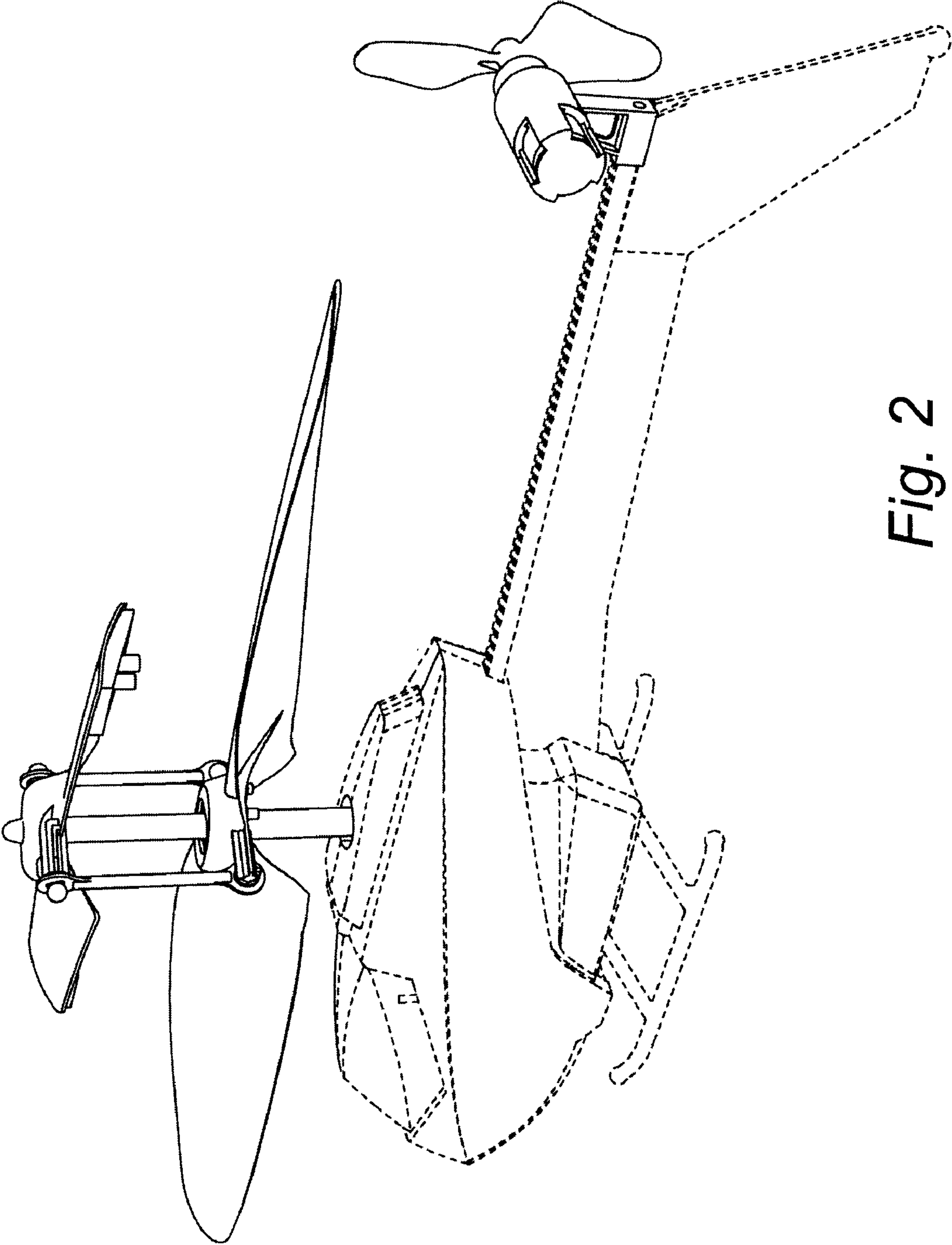

Fig. 2

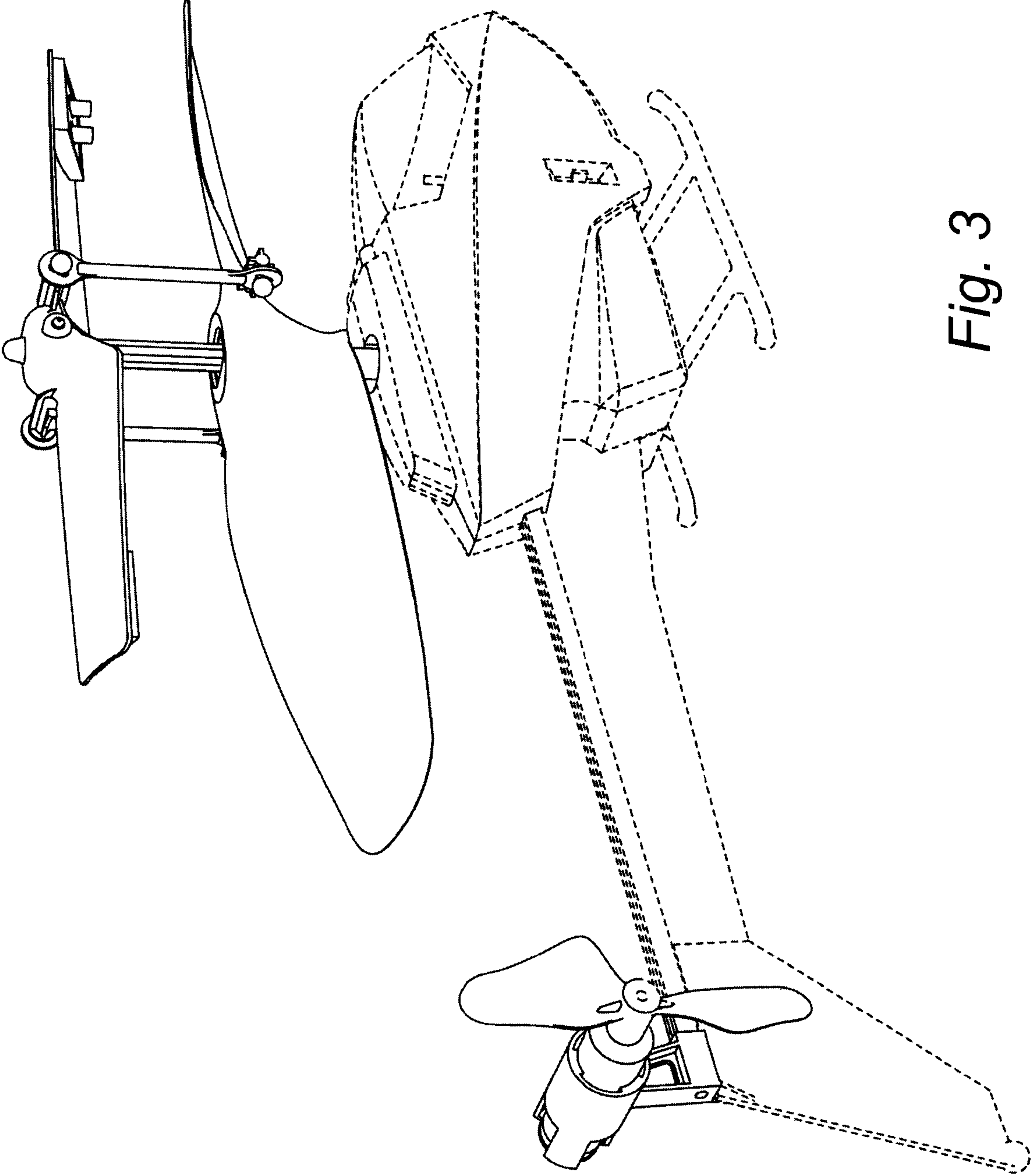

Fig. 3



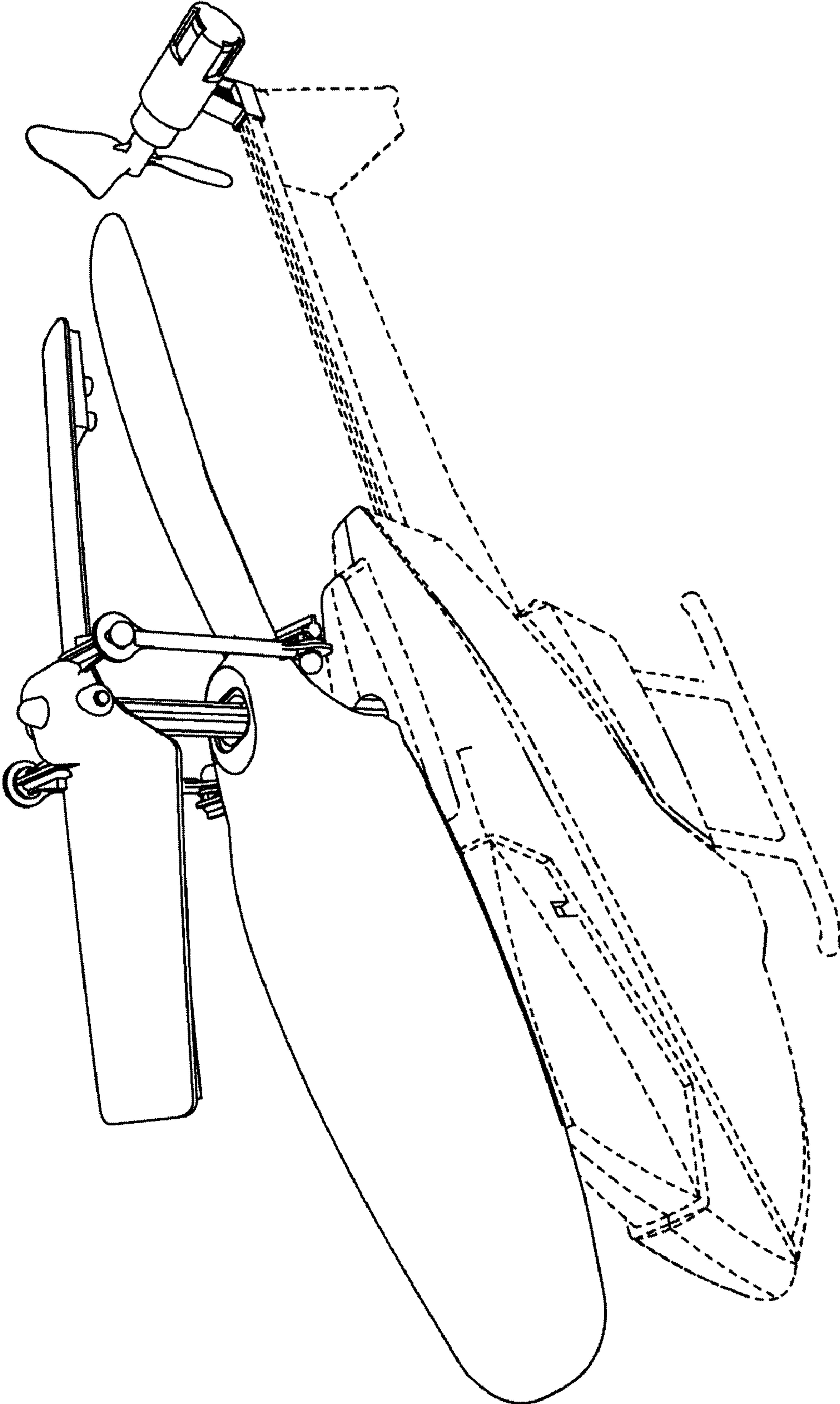

Fig. 4

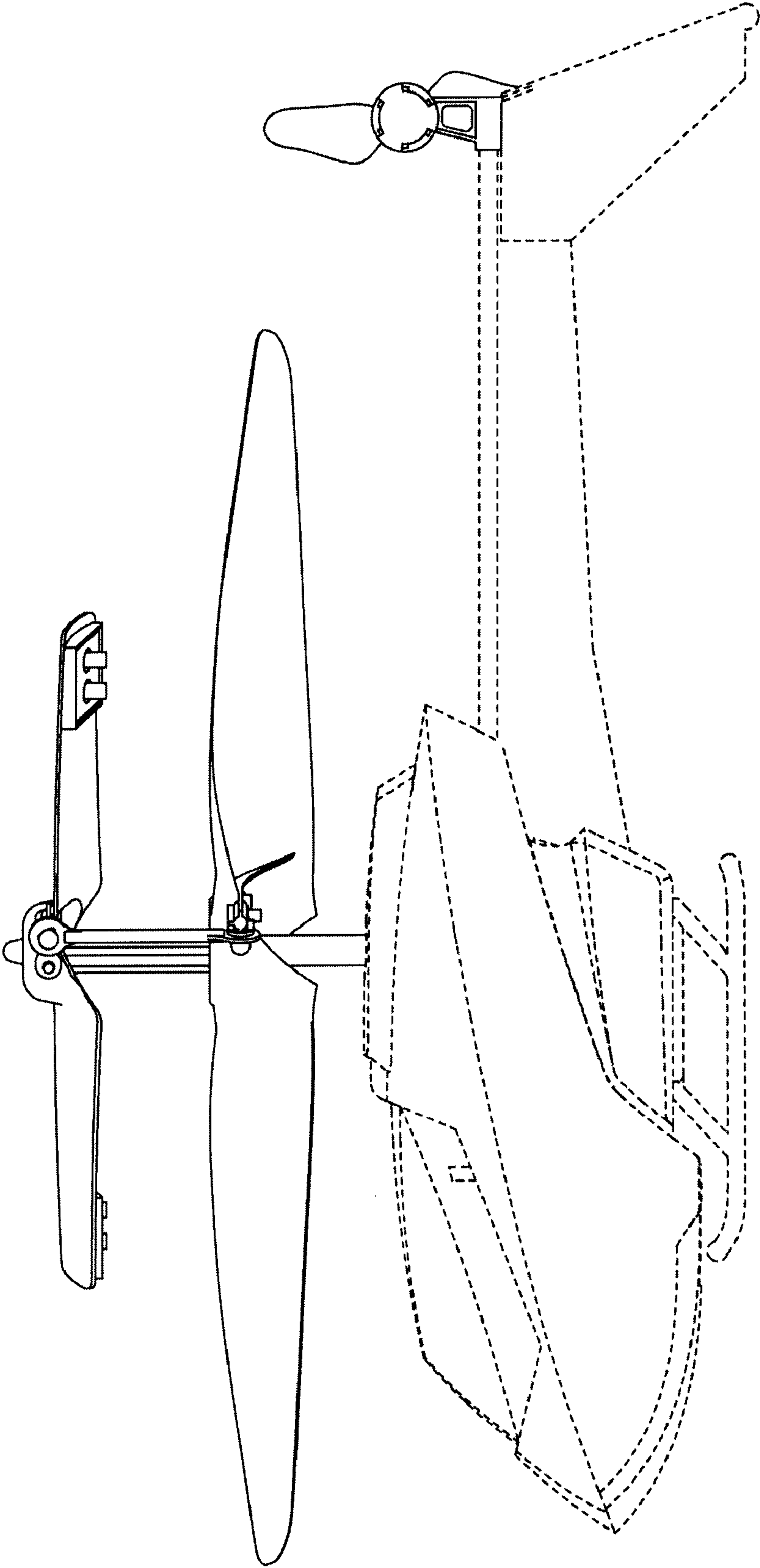

Fig. 5



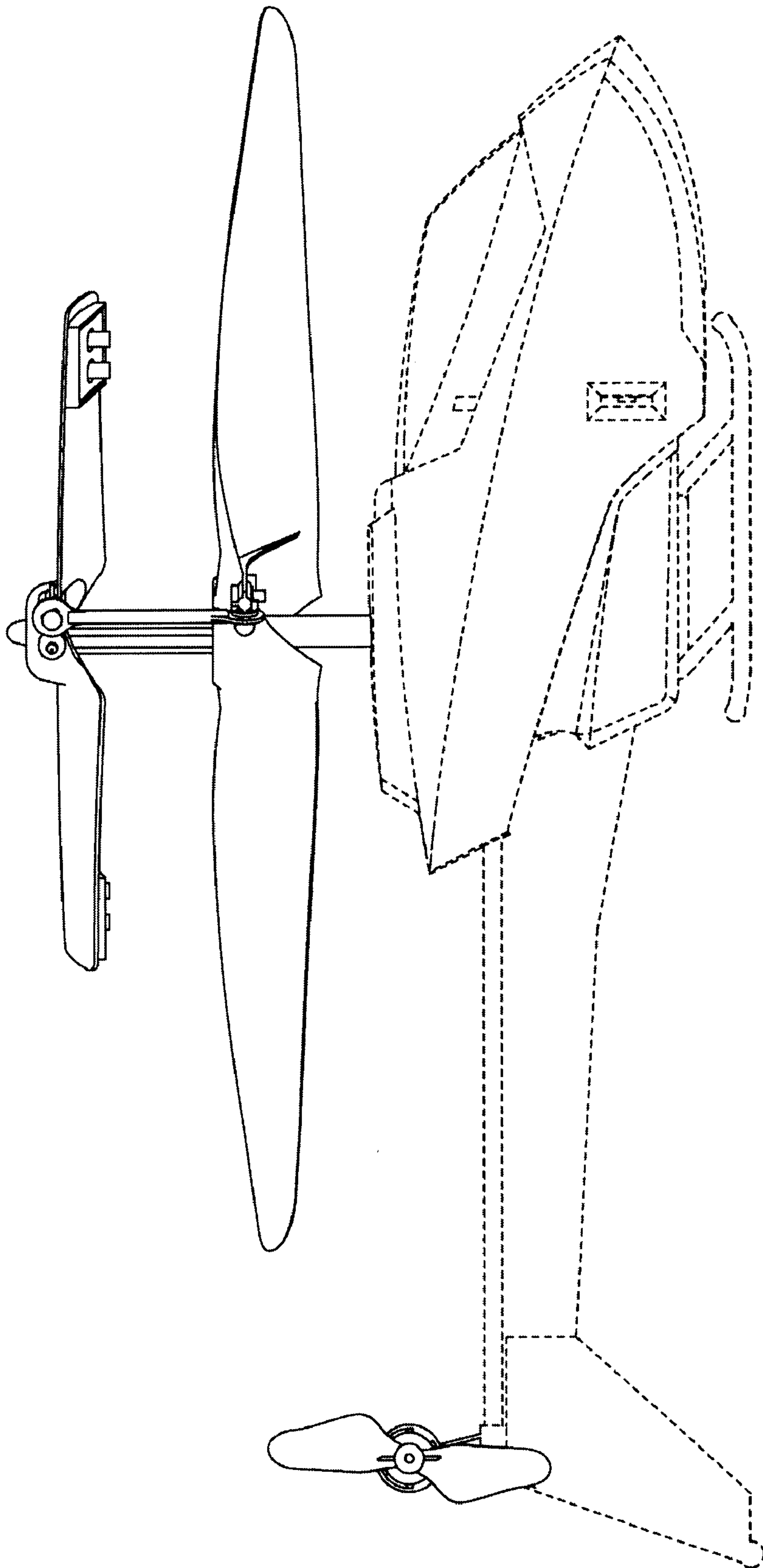

Fig. 6