

US00D580342S

(12) **United States Design Patent**
Cardozo

(10) **Patent No.:** **US D580,342 S**

(45) **Date of Patent:** **** Nov. 11, 2008**

(54) **PROTECTIVE DEVICE FOR AIRCRAFT
FUEL FILLER PORT**

(75) Inventor: **Leandro Aparecido Cardozo**, Sao Jose dos Campos-SP (BR)

(73) Assignee: **Embraer - Empresa Brasileira de Aeronautica S.A.**, Sao Jose Dos Campos - SP (BR)

(**) Term: **14 Years**

(21) Appl. No.: **29/298,678**

(22) Filed: **Dec. 10, 2007**

(51) **LOC (8) Cl.** **12-07**

(52) **U.S. Cl.** **D12/345; D23/391**

(58) **Field of Classification Search** D12/319,
D12/345, 400, 190, 194; 244/117 R, 135 R,
244/135 A; 296/97.22; D21/723-724; D23/259-261,
D23/263, 387, 391, 393
See application file for complete search history.

(56) **References Cited**

U.S. PATENT DOCUMENTS

| | | | | |
|--------------|--------|---------|-------|---------|
| D183,084 S * | 6/1958 | Carlson | | D21/723 |
| D323,023 S * | 1/1992 | Lazenby | | D23/259 |
| D350,999 S * | 9/1994 | Chen | | D21/724 |
| D355,958 S * | 2/1995 | Teskey | | D23/263 |
| D460,011 S * | 7/2002 | Rashed | | D10/96 |

* cited by examiner

Primary Examiner—Charles A. Rademaker

Assistant Examiner—Dana L Sipos

(74) *Attorney, Agent, or Firm*—Nixon & Vanderhye PC

(57) **CLAIM**

The ornamental design for a “protective device for aircraft fuel filler port,” as shown and described.

DESCRIPTION

This application is related to copending U.S. Appl. No. 11/953,836 filed on Dec. 10, 2007, the entire content of which is expressly incorporated herein by reference.

FIG. 1 is a top front perspective view of a protective device for aircraft fuel filler port which embodies my new and original design therefore;

FIG. 2 front elevational view thereof;

FIG. 3 is a rear elevational view thereof;

FIG. 4 is a top plan view thereof;

FIG. 5 is a bottom plan view thereof; and,

FIG. 6 is a right side elevational view thereof, the left side elevational view being a mirror image thereof.

The broken lines in FIGS. 1–6 represent structure which is in the environment of the claimed design, but which does not form part of the claimed design.

1 Claim, 2 Drawing Sheets

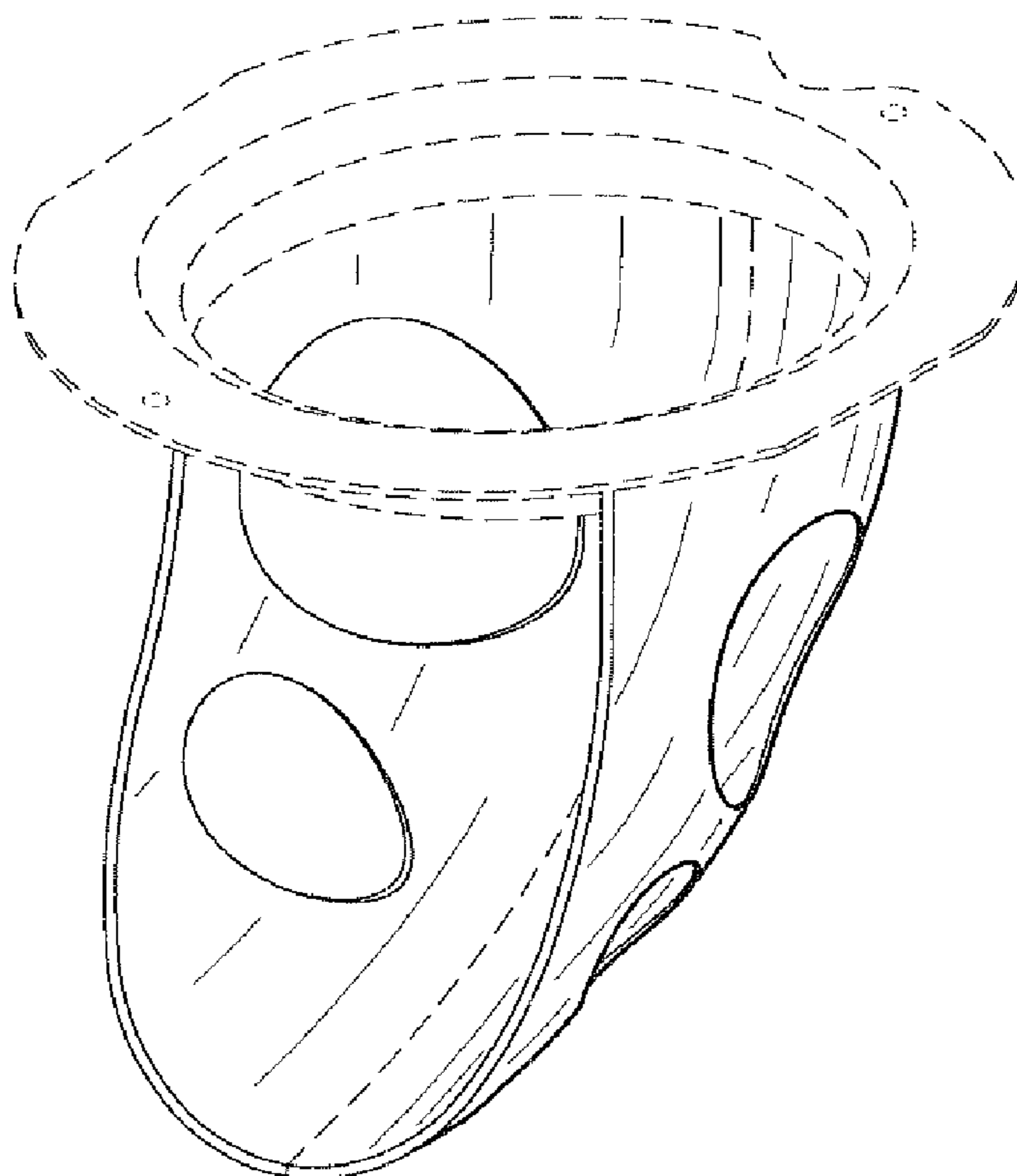

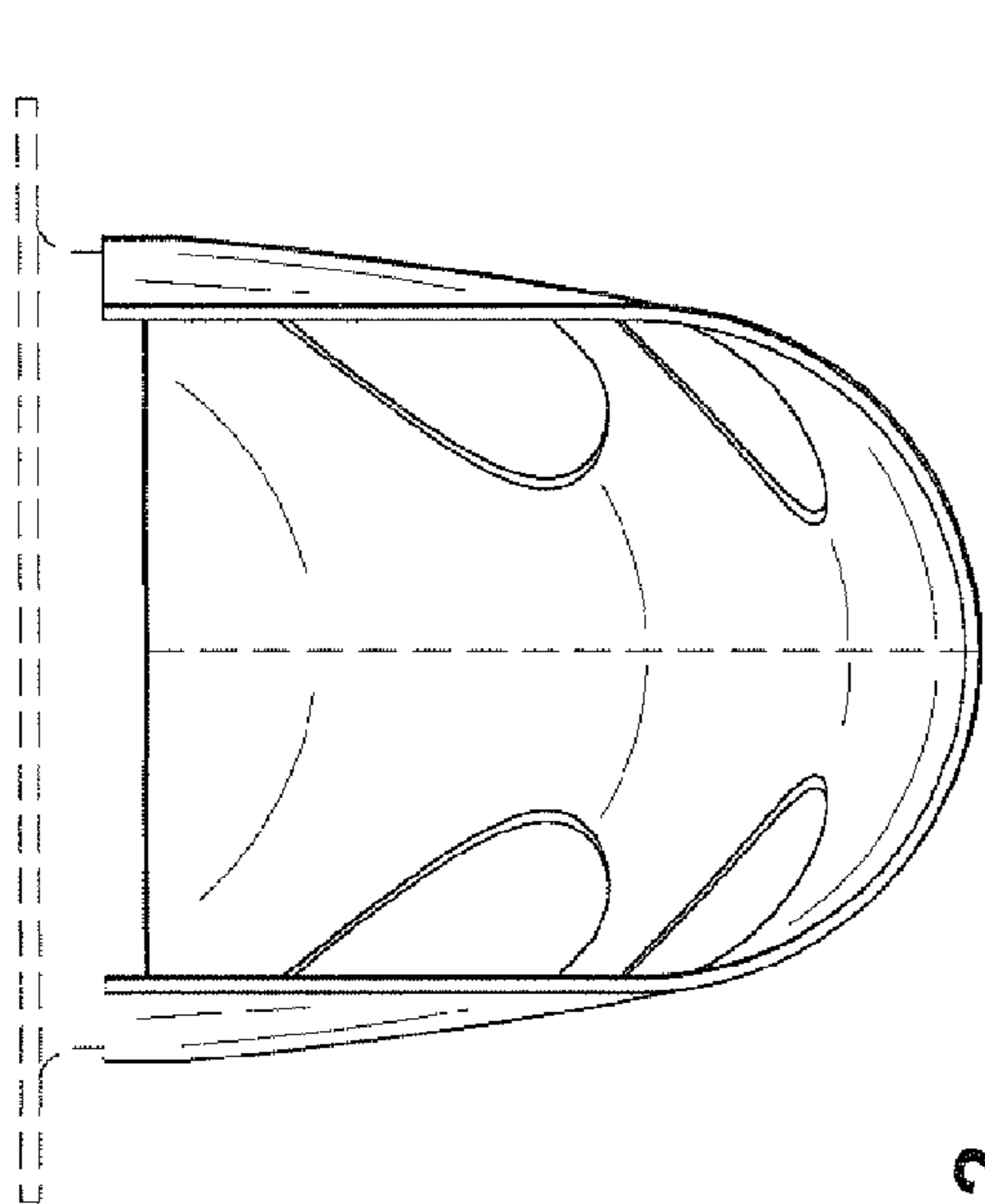

FIG. 2

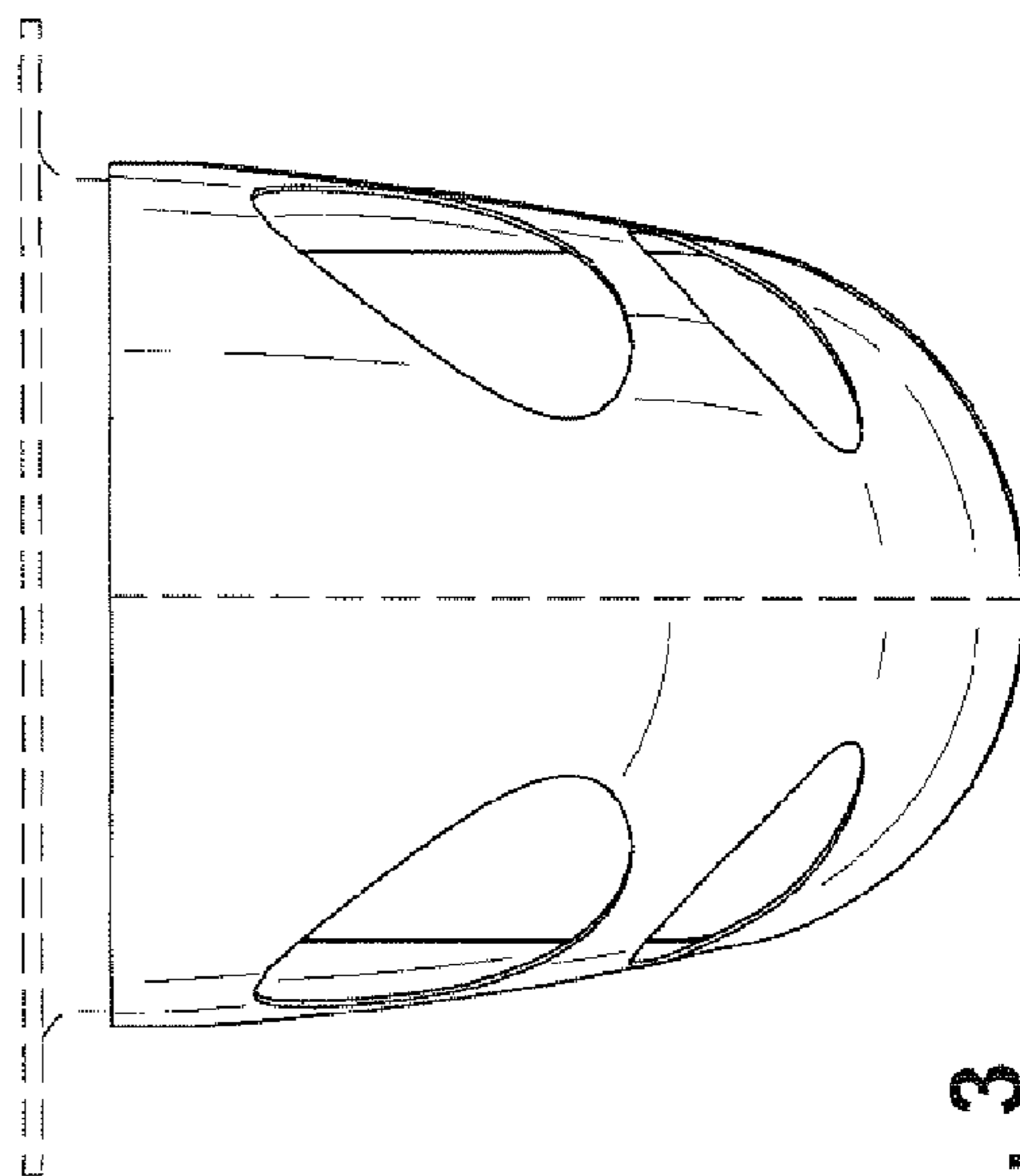

FIG. 3

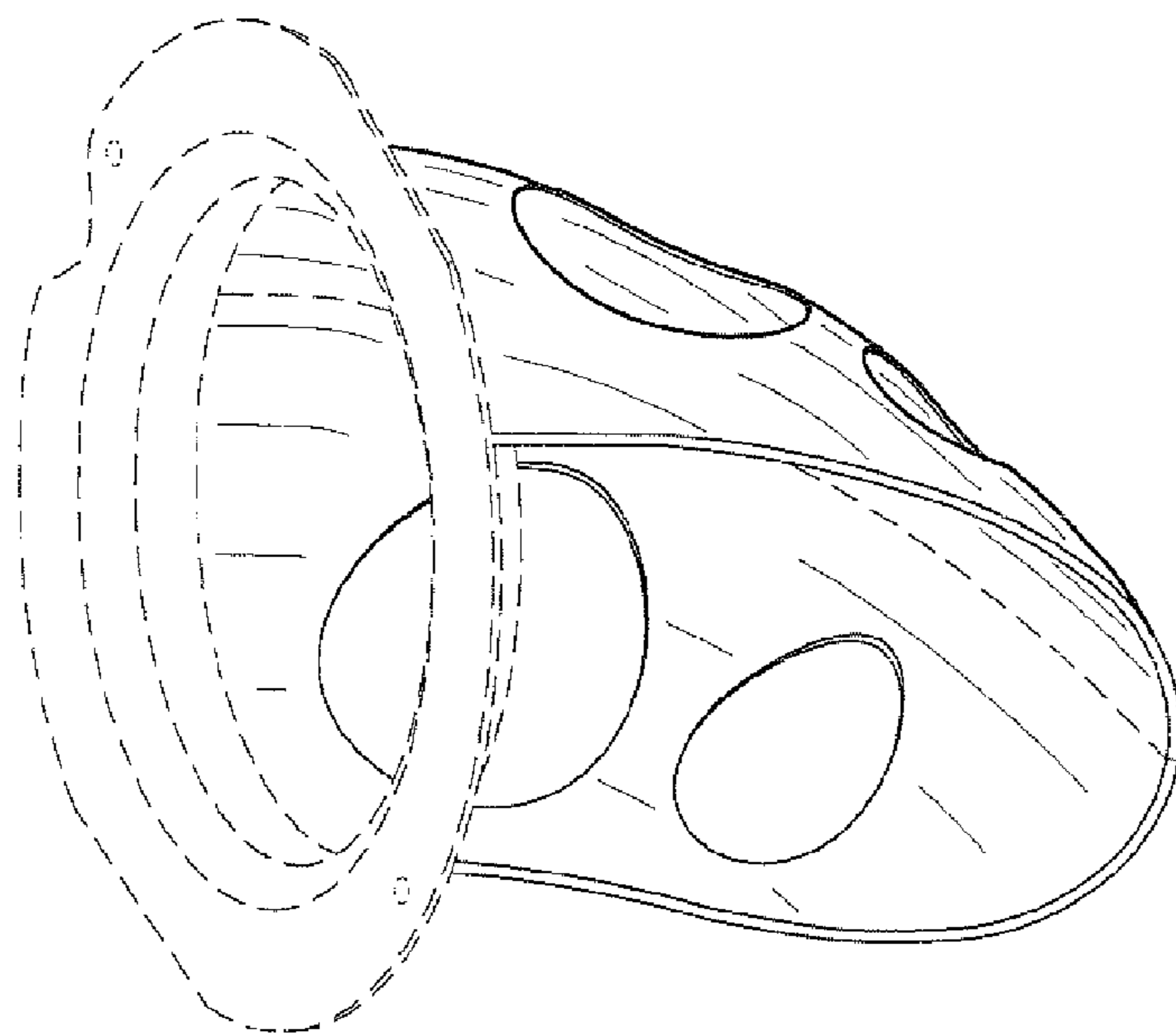

FIG. 1

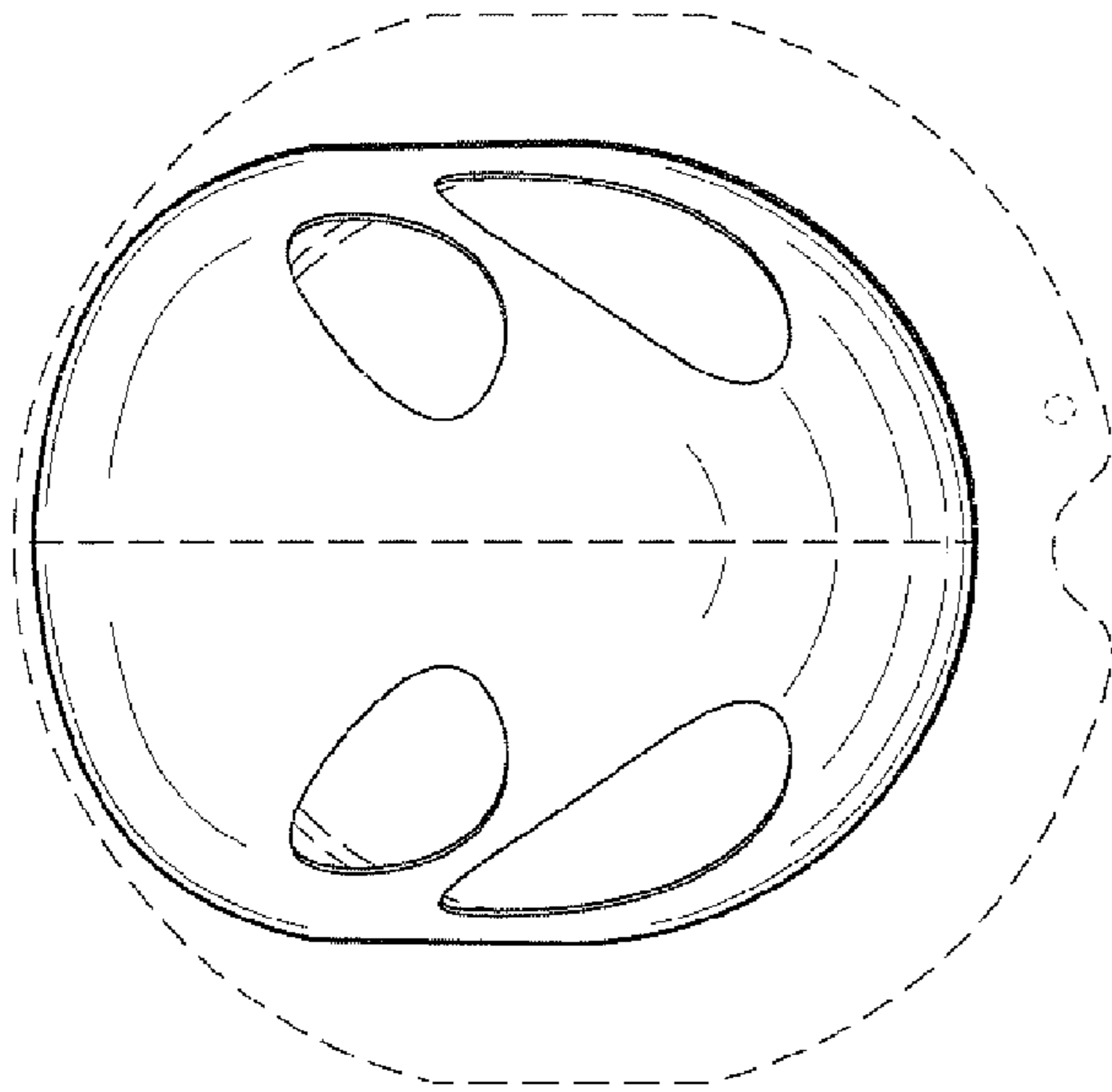

FIG. 5

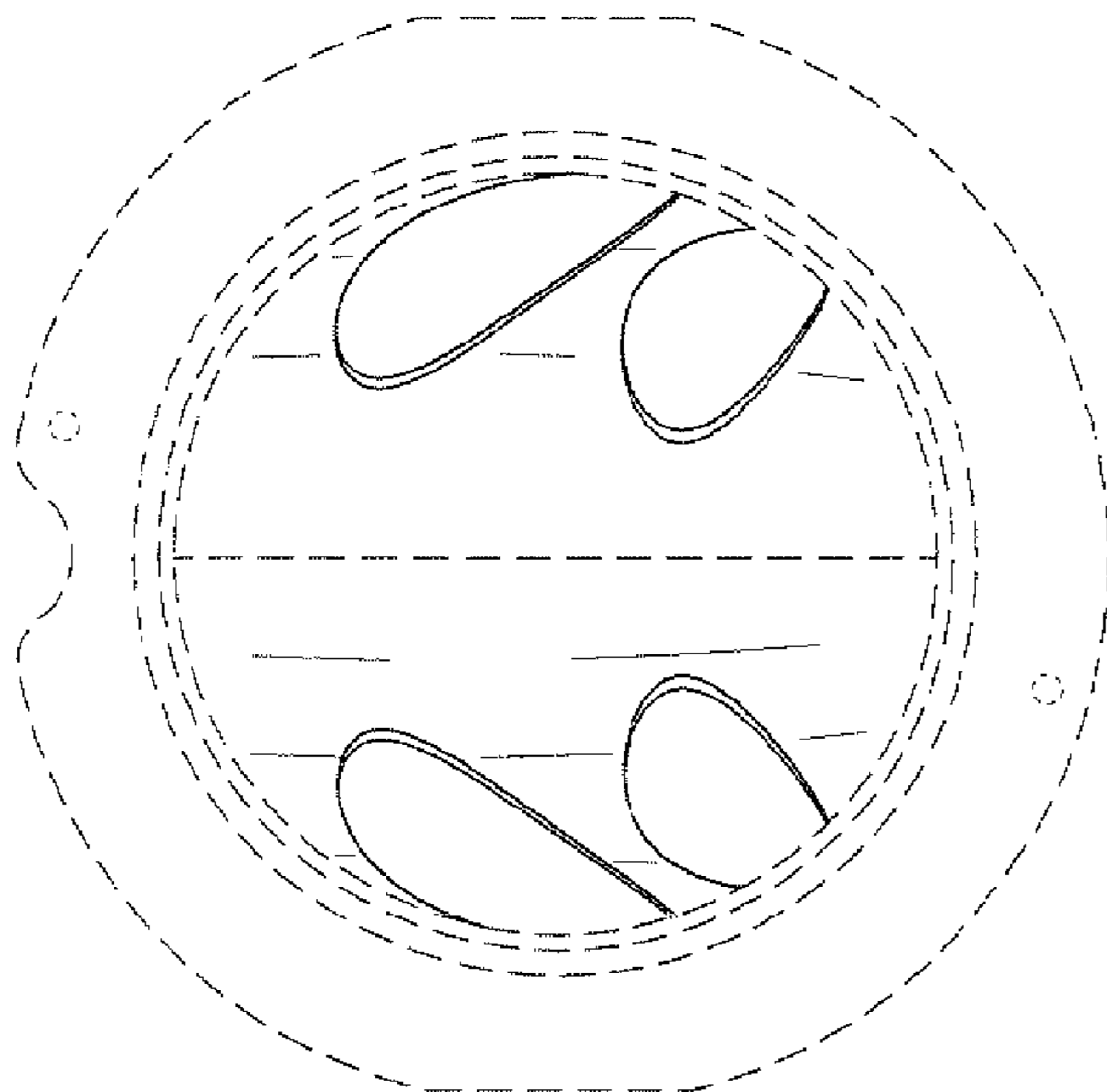

FIG. 4

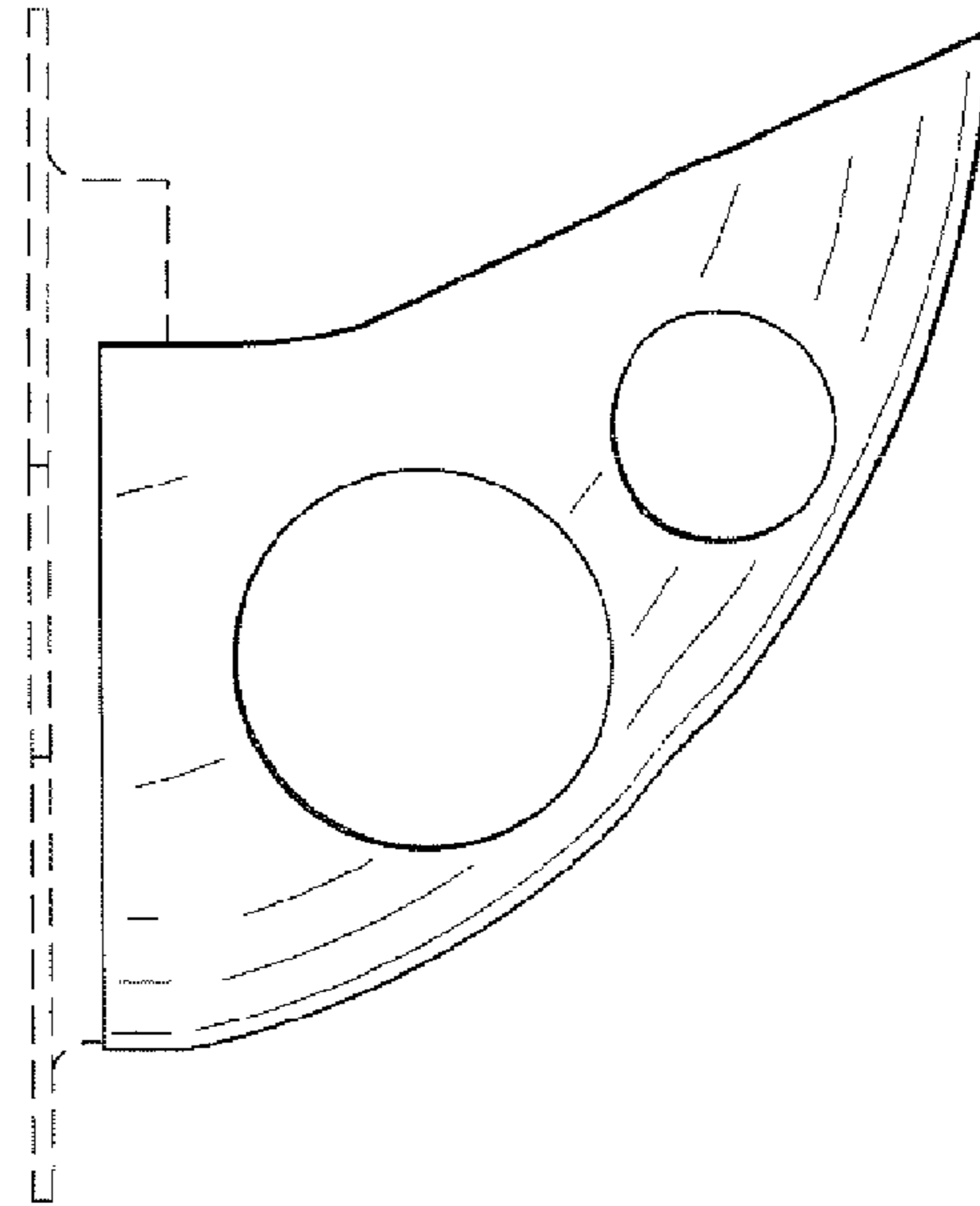

FIG. 6