



US00D580325S

(12) **United States Design Patent**
Sawabe et al.

(10) **Patent No.:** **US D580,325 S**
(45) **Date of Patent:** **** Nov. 11, 2008**

(54) **FRONT COWL FOR MOTORCYCLE**

(75) Inventors: **Akihiro Sawabe**, Wako (JP); **Hirotsugu Ueno**, Wako (JP)

(73) Assignee: **Honda Motor Co., Ltd.**, Tokyo (JP)

(**) Term: **14 Years**

(21) Appl. No.: **29/266,474**

(22) Filed: **Sep. 22, 2006**

(30) **Foreign Application Priority Data**

Mar. 23, 2006 (JP) 2006-007242

(51) **LOC (8) Cl.** **12-11**

(52) **U.S. Cl.** **D12/182; D12/126**

(58) **Field of Classification Search** D12/110,
D12/112, 114, 182, 186; 280/288.4, 304.3,
280/152.1–152.3, 770, 848, 852; 180/219,
180/220, 225; 296/78.1, 180.1, 192, 193.01,
296/193.05, 193.09

See application file for complete search history.

(56) **References Cited**

U.S. PATENT DOCUMENTS

D500,464 S 1/2005 Ban et al.
D515,485 S * 2/2006 Sawabe et al. D12/182
D538,718 S * 3/2007 Tako et al. D12/182
D545,738 S * 7/2007 Tako et al. D12/182

OTHER PUBLICATIONS

Japanese Motorcycle Magazine, Feb. 1, 2006, pp. 84 and 85 (www.motormagazine.co.jp).

Japanese Motorcycle Magazine, Jan. 1, 2006, p. 65 (www.motormagazine.co.jp).

* cited by examiner

Primary Examiner—Cathron Brooks

Assistant Examiner—Linda Brooks

(74) *Attorney, Agent, or Firm*—Westerman, Hattori, Daniels & Adrian, LLP.

(57) **CLAIM**

The ornamental design for a front cowl for motorcycle, as shown and described.

DESCRIPTION

FIG. 1 is a perspective view from the right side of a front cowl for motorcycle.

FIG. 2 is a perspective view of the opposite side shown in FIG. 1.

FIG. 3 is a perspective view from the left side thereof.

FIG. 4 is a perspective view of the opposite side shown in FIG. 3.

FIG. 5 is a front elevation view thereof.

FIG. 6 is a rear elevation view thereof.

FIG. 7 is a right side elevation view thereof.

FIG. 8 is a left side elevation view thereof.

FIG. 9 is a top plan view thereof.

FIG. 10 is a bottom plan view thereof; and,

FIG. 11 is a view showing the claimed front cowl for motorcycle shown on a reduced scale and in position of use on a motorcycle, which is shown in broken lines and forms no part of the claimed design.

The portions shown in broken lines form no part of the claimed design.

1 Claim, 11 Drawing Sheets

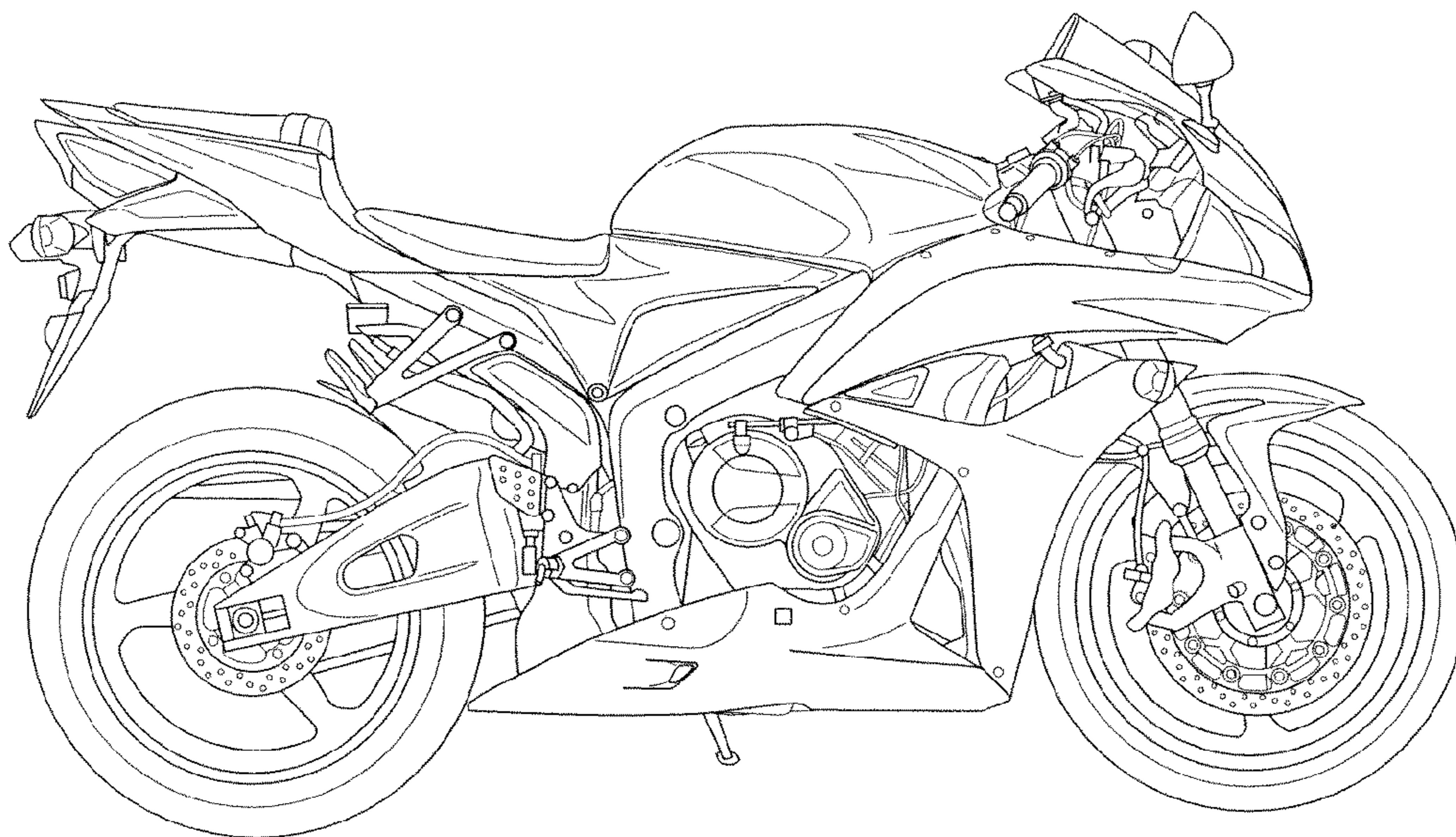

FIG. 1

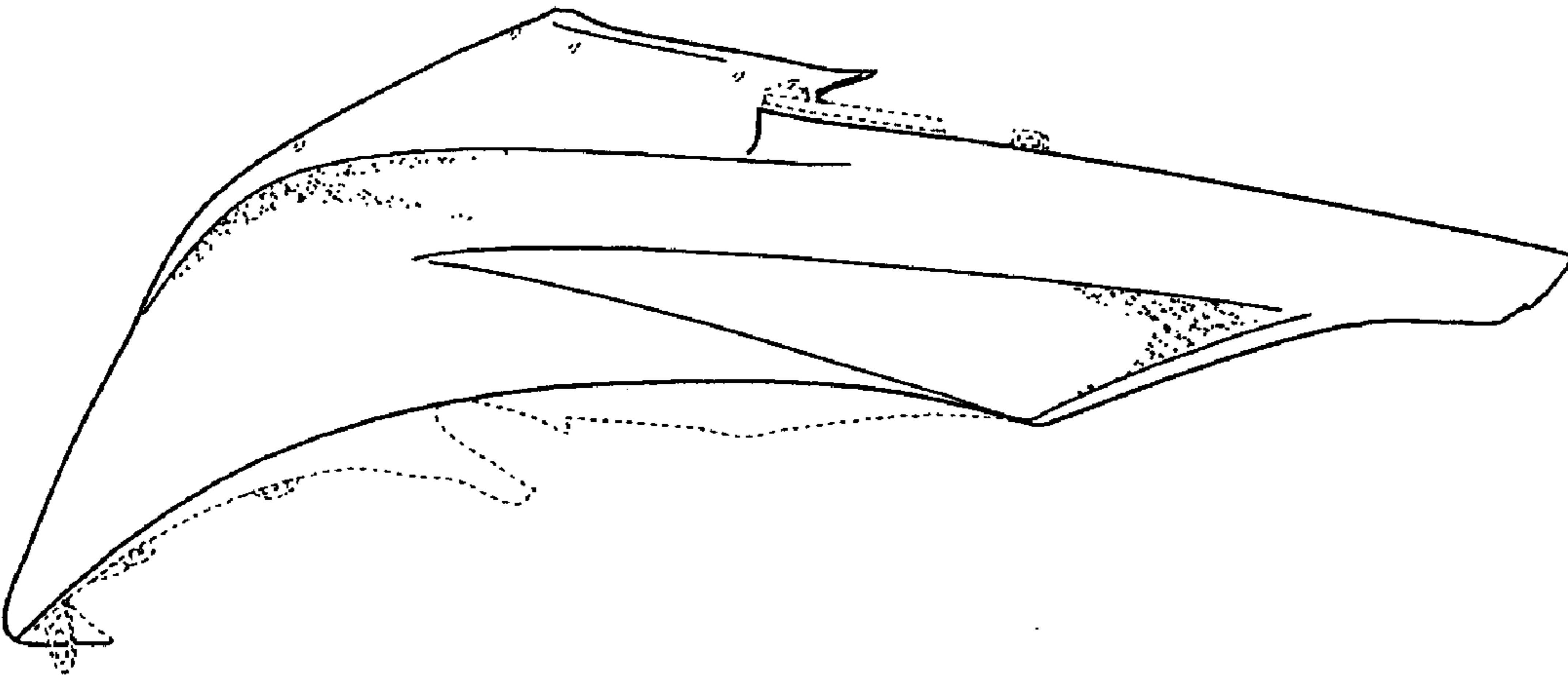

FIG. 2

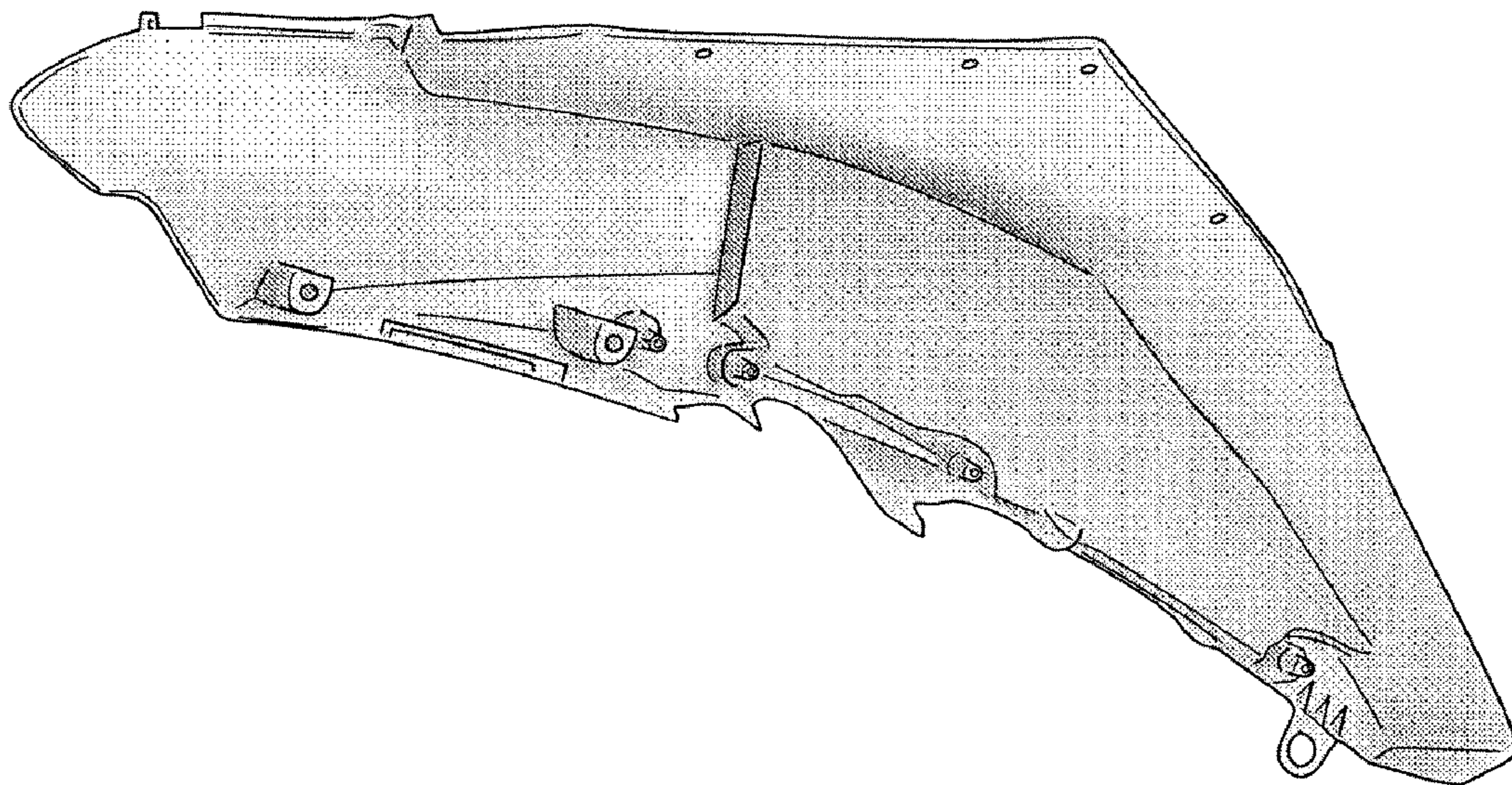

FIG. 3

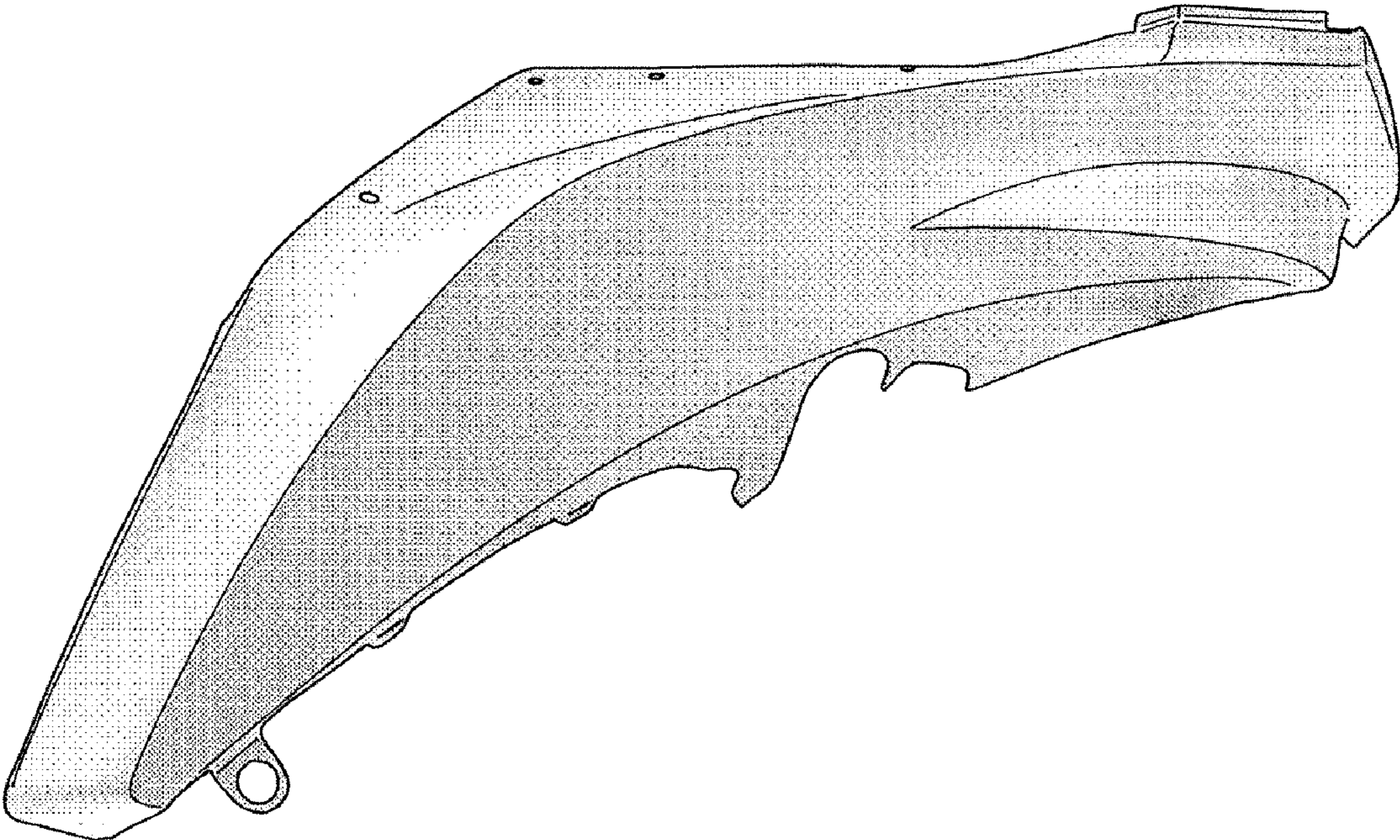

FIG. 4

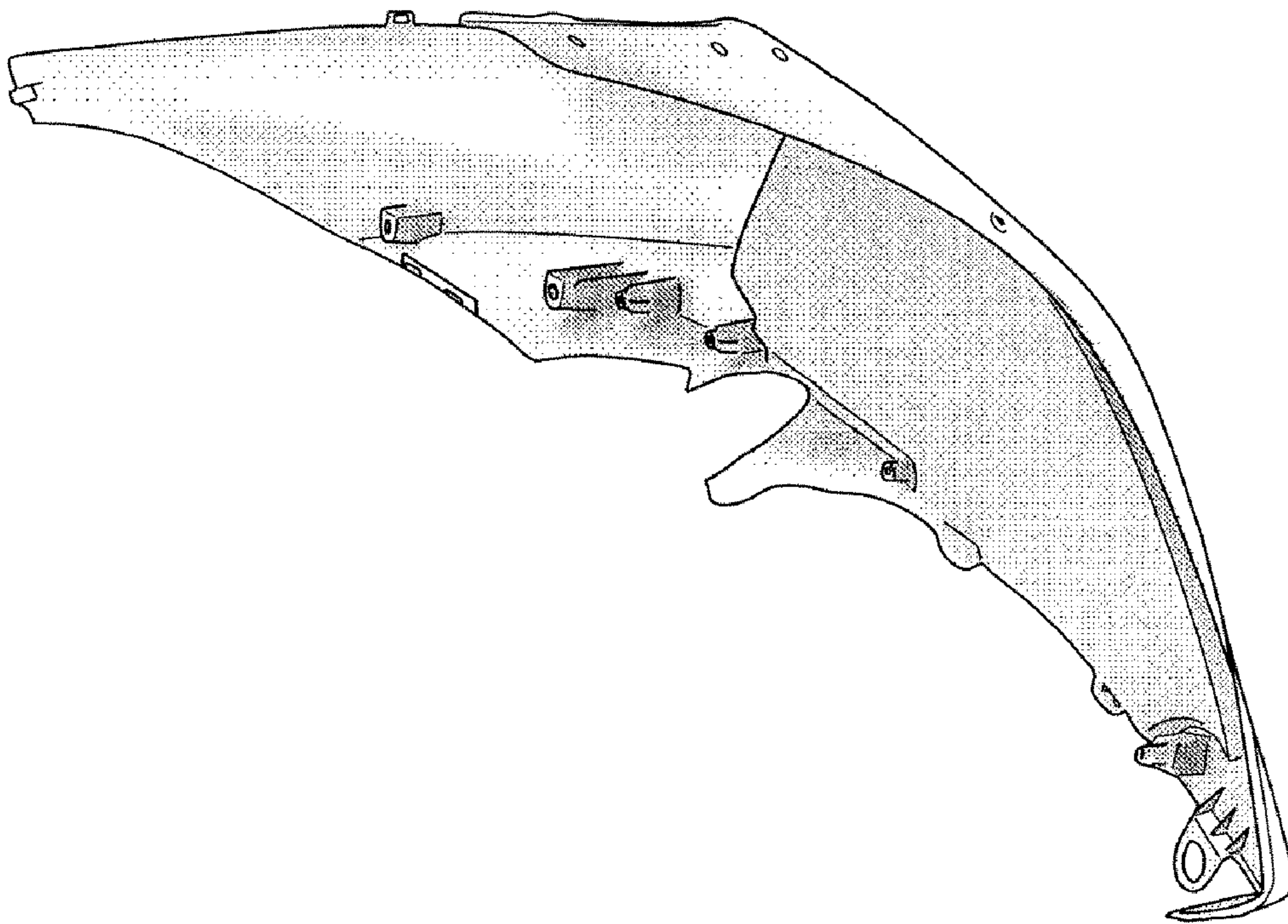

FIG. 5

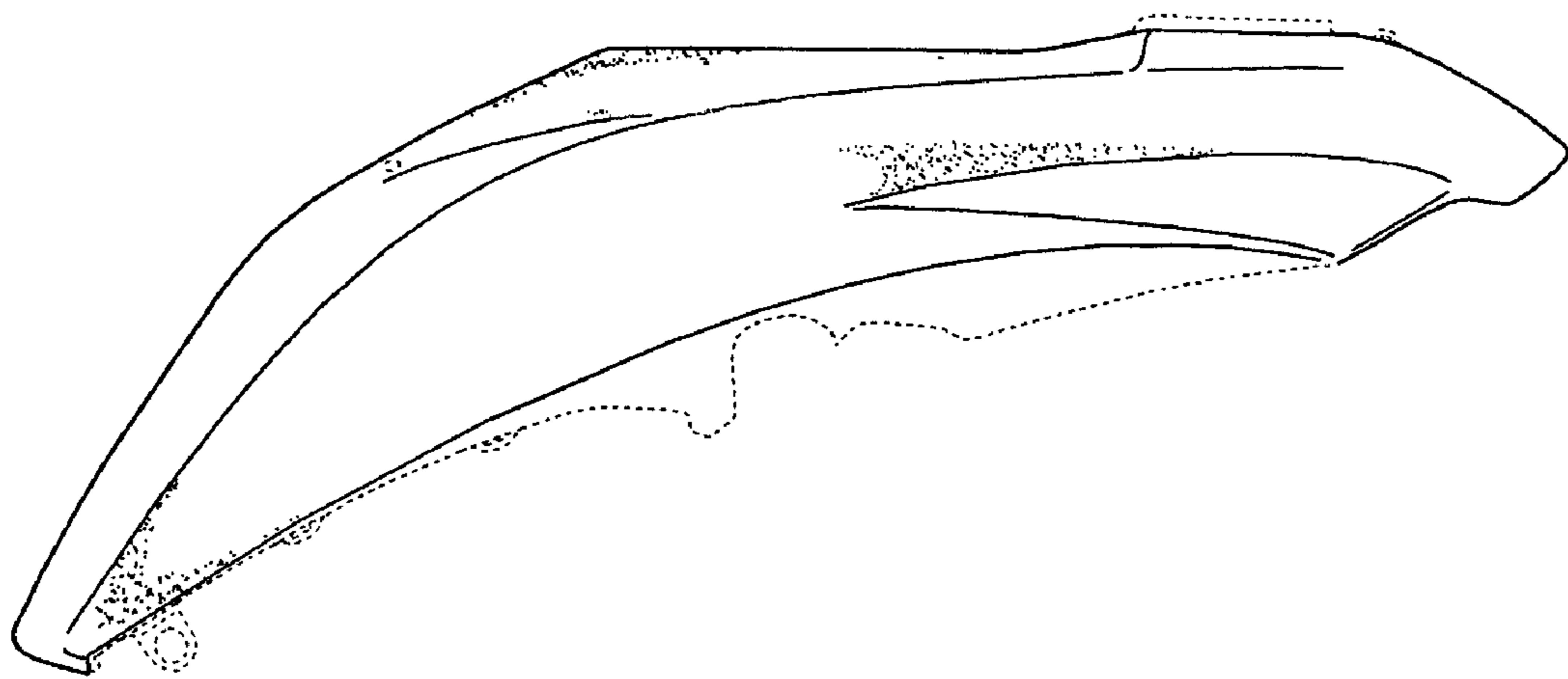

FIG. 6

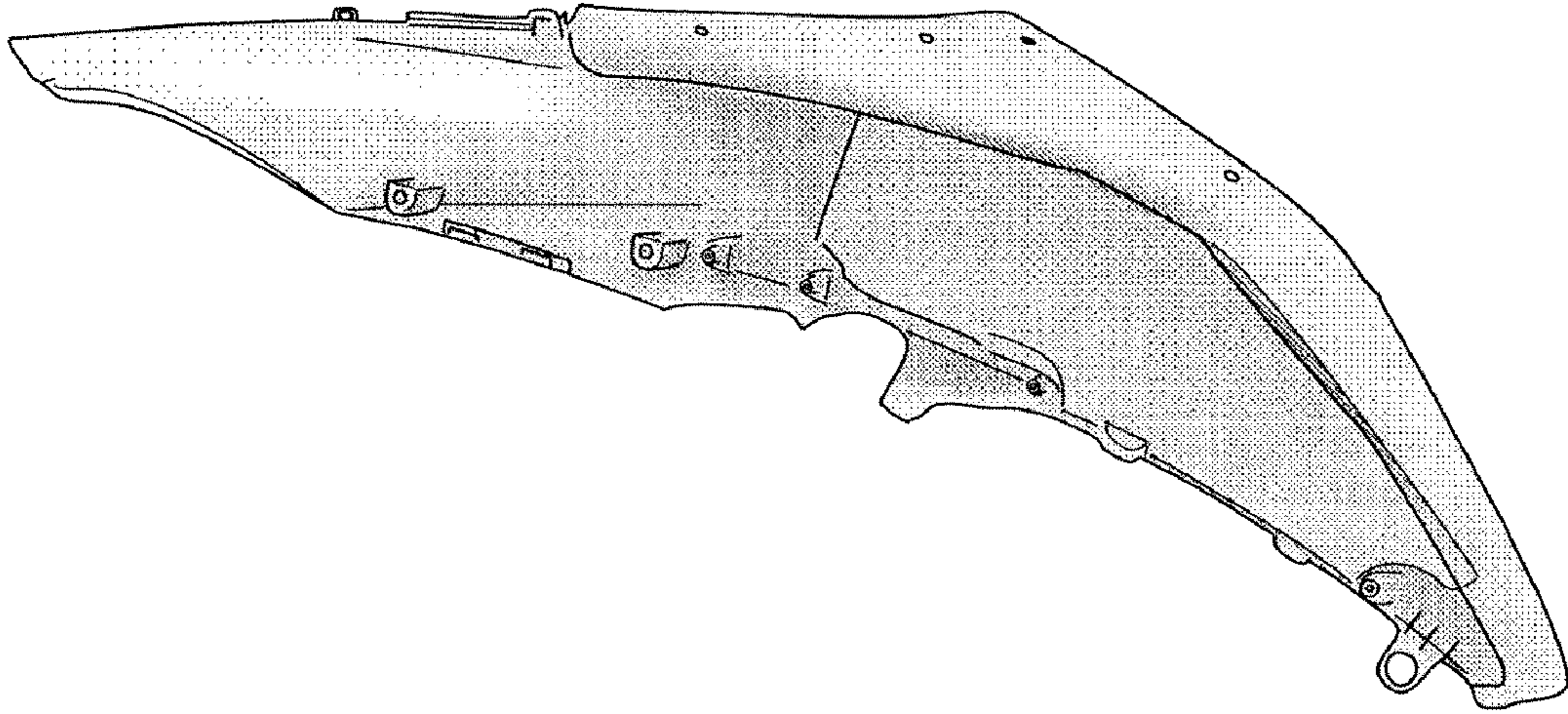

FIG. 7

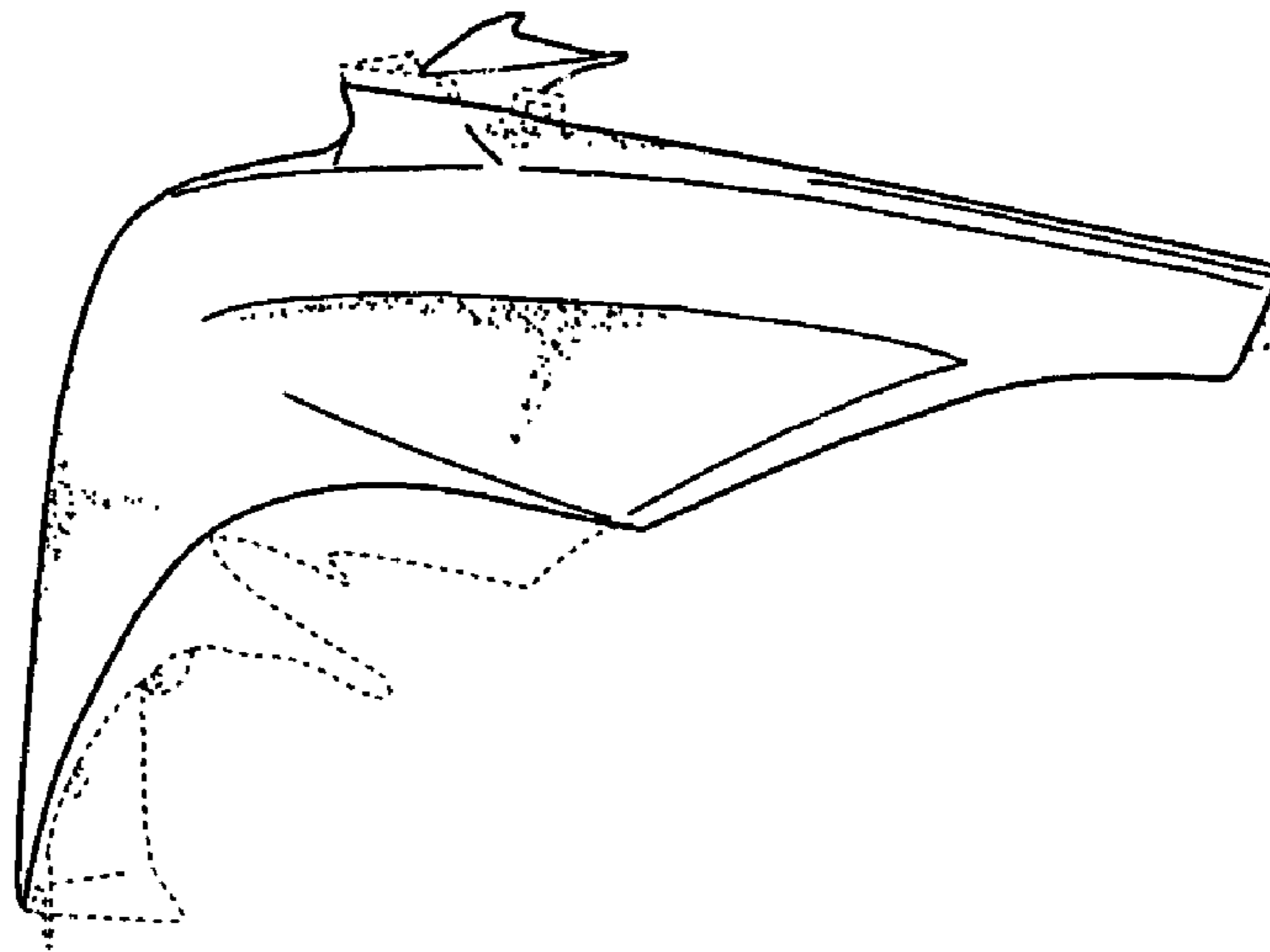

FIG. 8

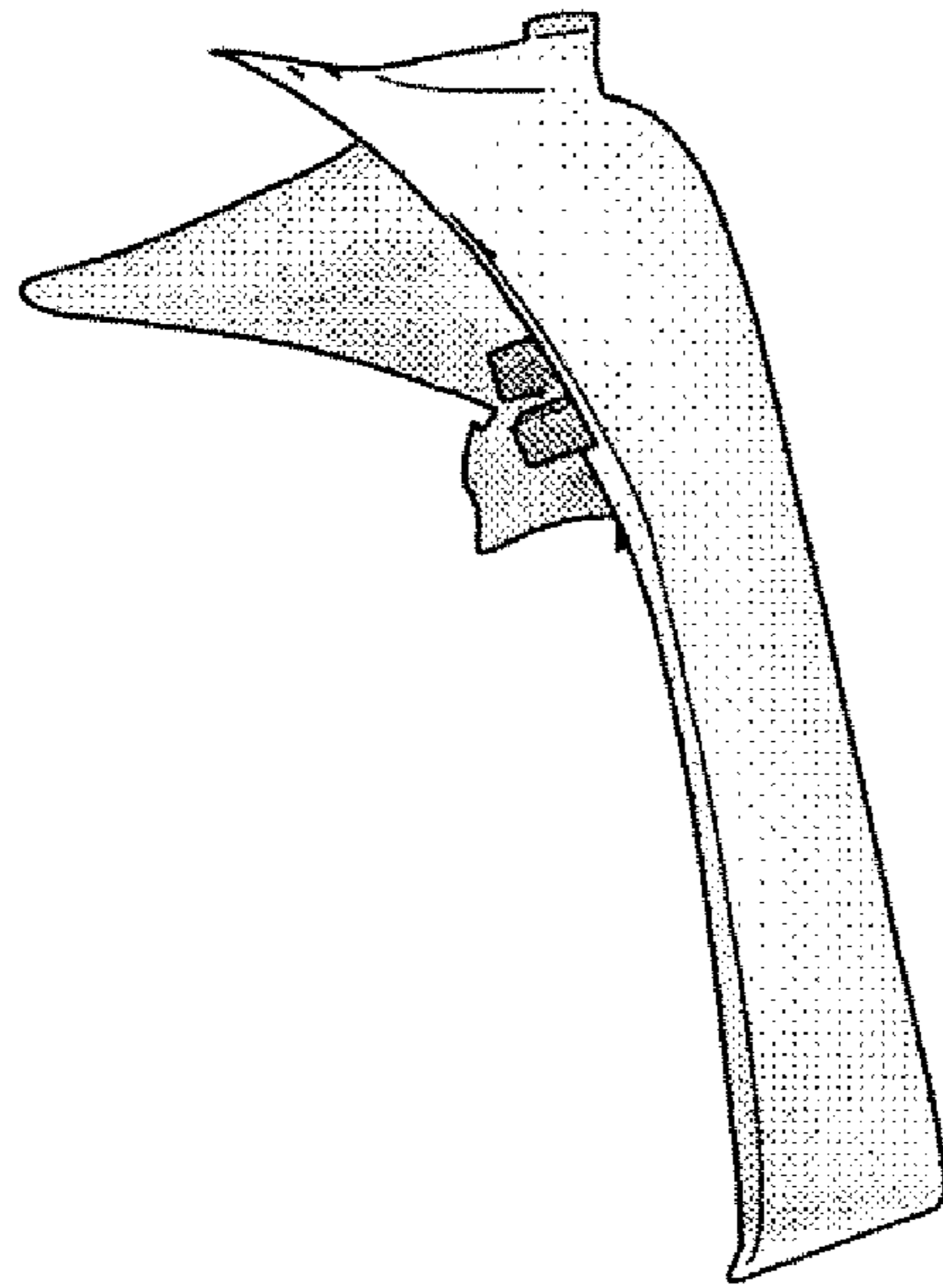

FIG. 9

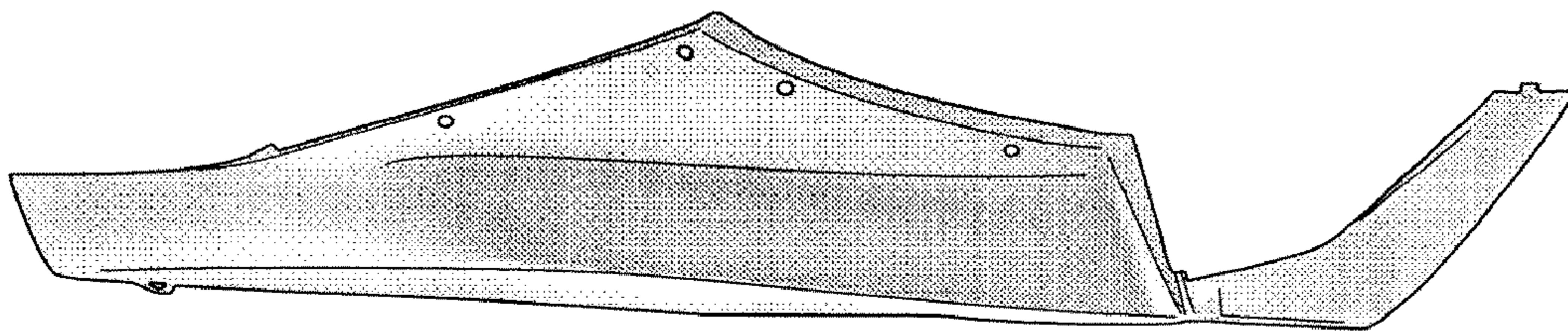

FIG. 10

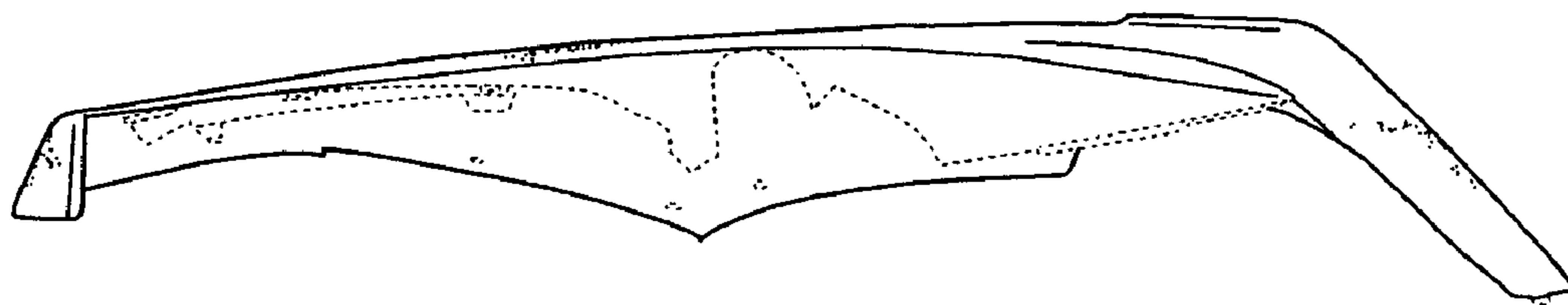
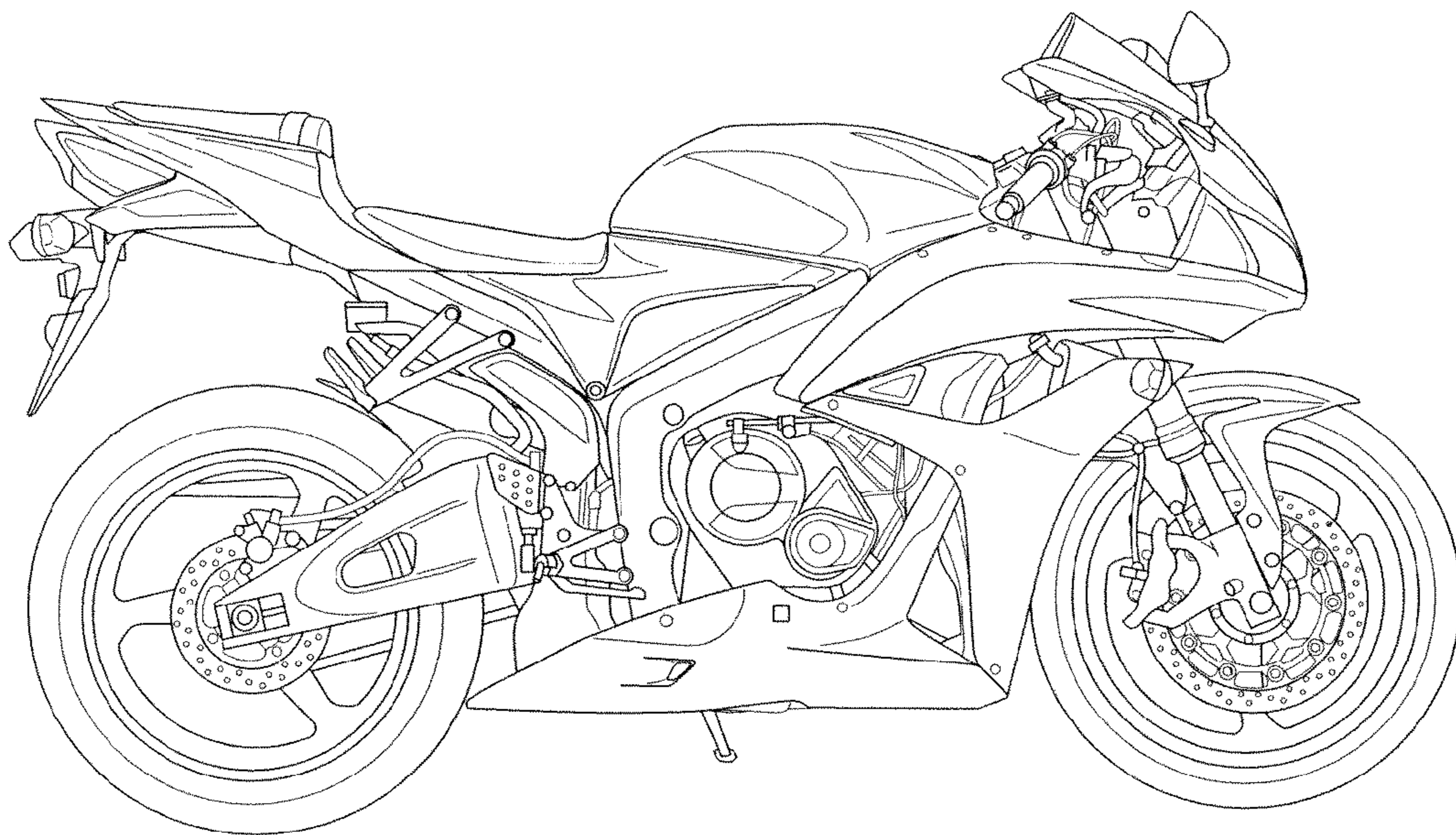

FIG. 11



UNITED STATES PATENT AND TRADEMARK OFFICE
CERTIFICATE OF CORRECTION

PATENT NO. : Des. 580,325 S
APPLICATION NO. : 29/266474
DATED : November 11, 2008
INVENTOR(S) : Sawabe et al.

Page 1 of 9

It is certified that error appears in the above-identified patent and that said Letters Patent is hereby corrected as shown below:

Title page illustrating a figure(s) should be deleted, and replaced with title page illustrating a figure(s). (attached)

Delete drawing sheets 2, 3, 4, 6, 8, 9 and 11, and replace with drawing sheets 2, 3, 4, 6, 8, 9 and 11. (attached)

Signed and Sealed this

Fourteenth Day of April, 2009

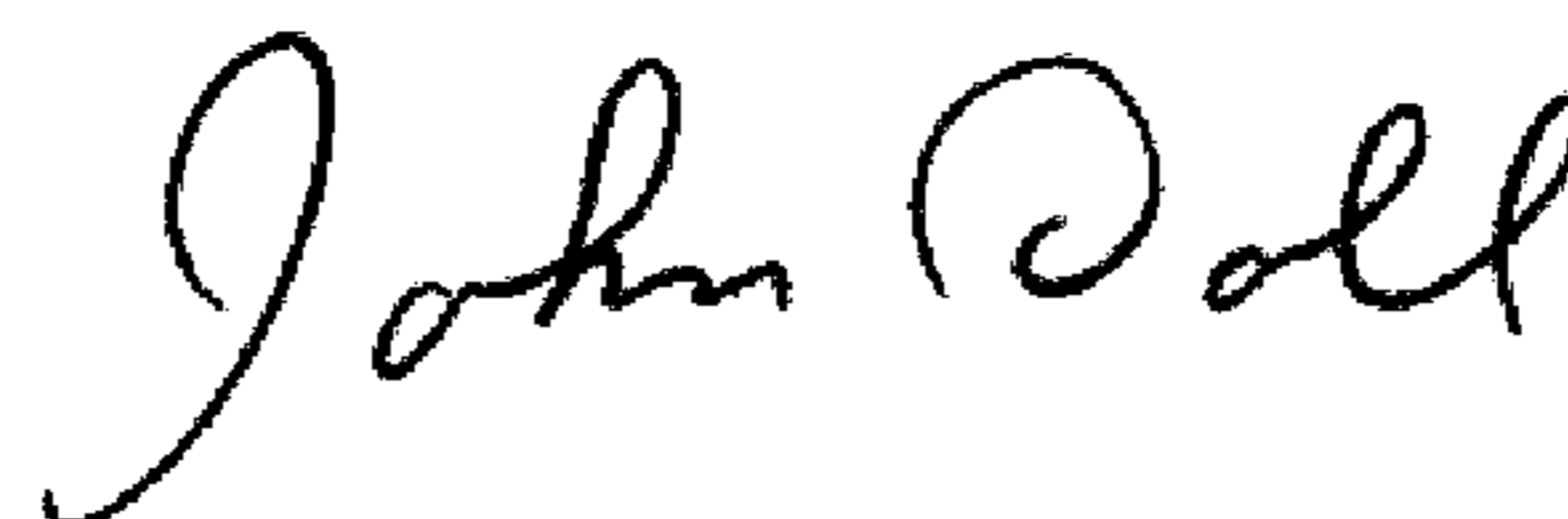

JOHN DOLL

Acting Director of the United States Patent and Trademark Office

(12) **United States Design Patent**
Sawabe et al.

(10) **Patent No.:** **US D580,325 S**
(45) **Date of Patent:** **** Nov. 11, 2008**

(54) **FRONT COWL FOR MOTORCYCLE**
(75) Inventors: **Akihiro Sawabe**, Wako (JP); **Hirotsugu Ueno**, Wako (JP)
(73) Assignee: **Honda Motor Co., Ltd.**, Tokyo (JP)
(**) Term: **14 Years**
(21) Appl. No.: **29/266,474**
(22) Filed: **Sep. 22, 2006**
(30) **Foreign Application Priority Data**
Mar. 23, 2006 (JP) 2006-007242
(51) **LOC (8) Cl.** **12-11**
(52) **U.S. Cl.** **D12/182; D12/126**
(58) **Field of Classification Search** **D12/110,**
D12/112, 114, 182, 186; 280/288.4, 304.3,
280/152.1-152.3, 770, 848, 852; 180/219,
180/220, 225; 296/78.1, 180.1, 192, 193.01,
296/193.05, 193.09
See application file for complete search history.

Japanese Motorcycle Magazine, Jan. 1, 2006, p. 65 (www.motormagazine.co.jp).
* cited by examiner
Primary Examiner—Cathron Brooks
Assistant Examiner—Linda Brooks
(74) *Attorney, Agent, or Firm*—Westerman, Hattori, Daniels & Adrian, L.L.P.

(57) **CLAIM**

The ornamental design for a front cowl for motorcycle, as shown and described.

DESCRIPTION

FIG. 1 is a perspective view from the right side of a front cowl for motorcycle.
FIG. 2 is a perspective view of the opposite side shown in FIG. 1.
FIG. 3 is a perspective view from the left side thereof.
FIG. 4 is a perspective view of the opposite side shown in FIG. 3.
FIG. 5 is a front elevation view thereof.
FIG. 6 is a rear elevation view thereof.
FIG. 7 is a right side elevation view thereof.
FIG. 8 is a left side elevation view thereof.
FIG. 9 is a top plan view thereof.
FIG. 10 is a bottom plan view thereof; and,
FIG. 11 is a view showing the claimed front cowl for motorcycle shown on a reduced scale and in position of use on a motorcycle, which is shown in broken lines and forms no part of the claimed design.

The portions shown in broken lines form no part of the claimed design.

(56) **References Cited**
U.S. PATENT DOCUMENTS
D500,464 S 1/2005 Ban et al.
D515,485 S * 2/2006 Sawabe et al. D12/182
D538,718 S * 3/2007 Tako et al. D12/182
D545,738 S * 7/2007 Tako et al. D12/182

OTHER PUBLICATIONS
Japanese Motorcycle Magazine, Feb. 1, 2006, pp. 84 and 85 (www.motormagazine.co.jp).

1 Claim, 11 Drawing Sheets

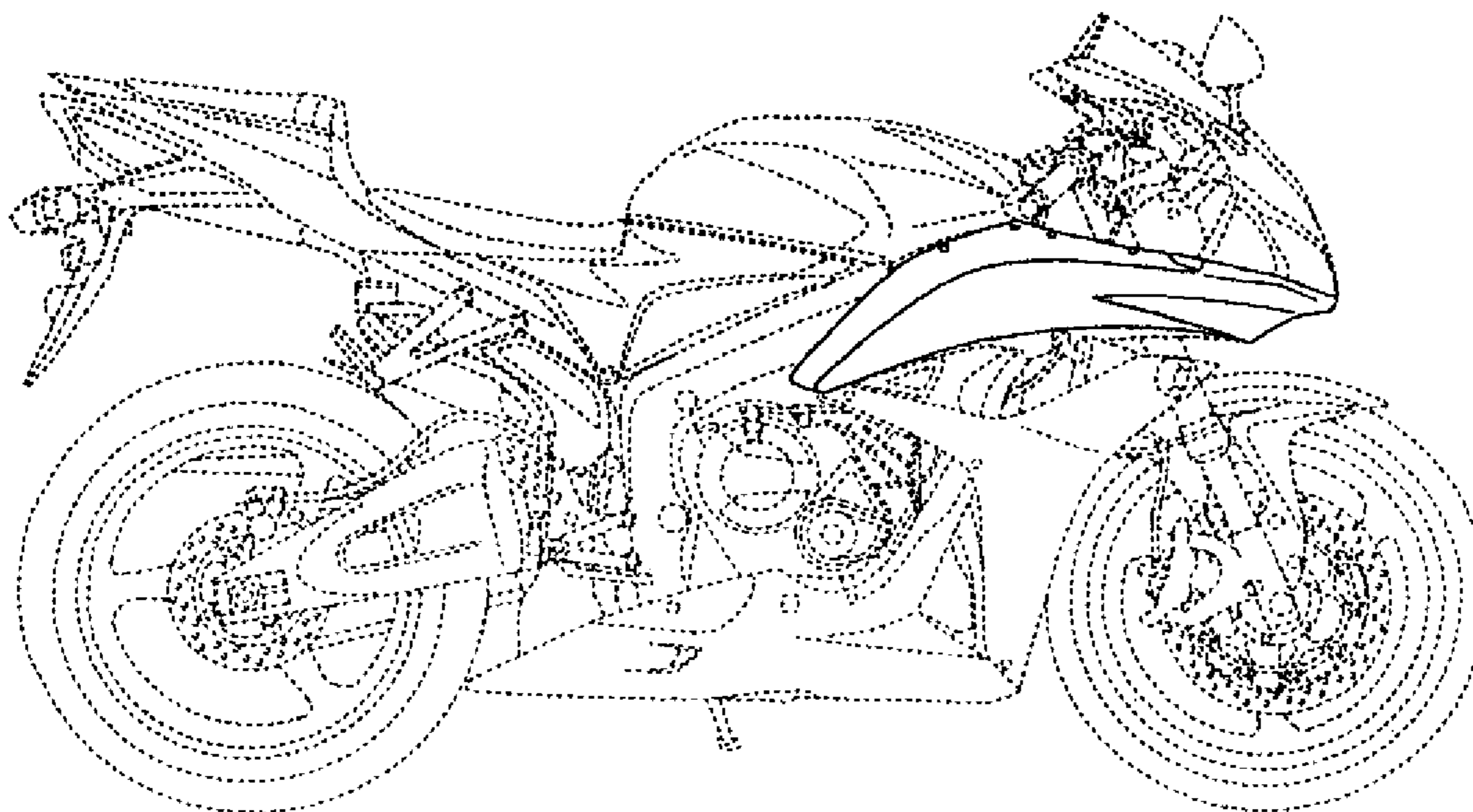

FIG. 2

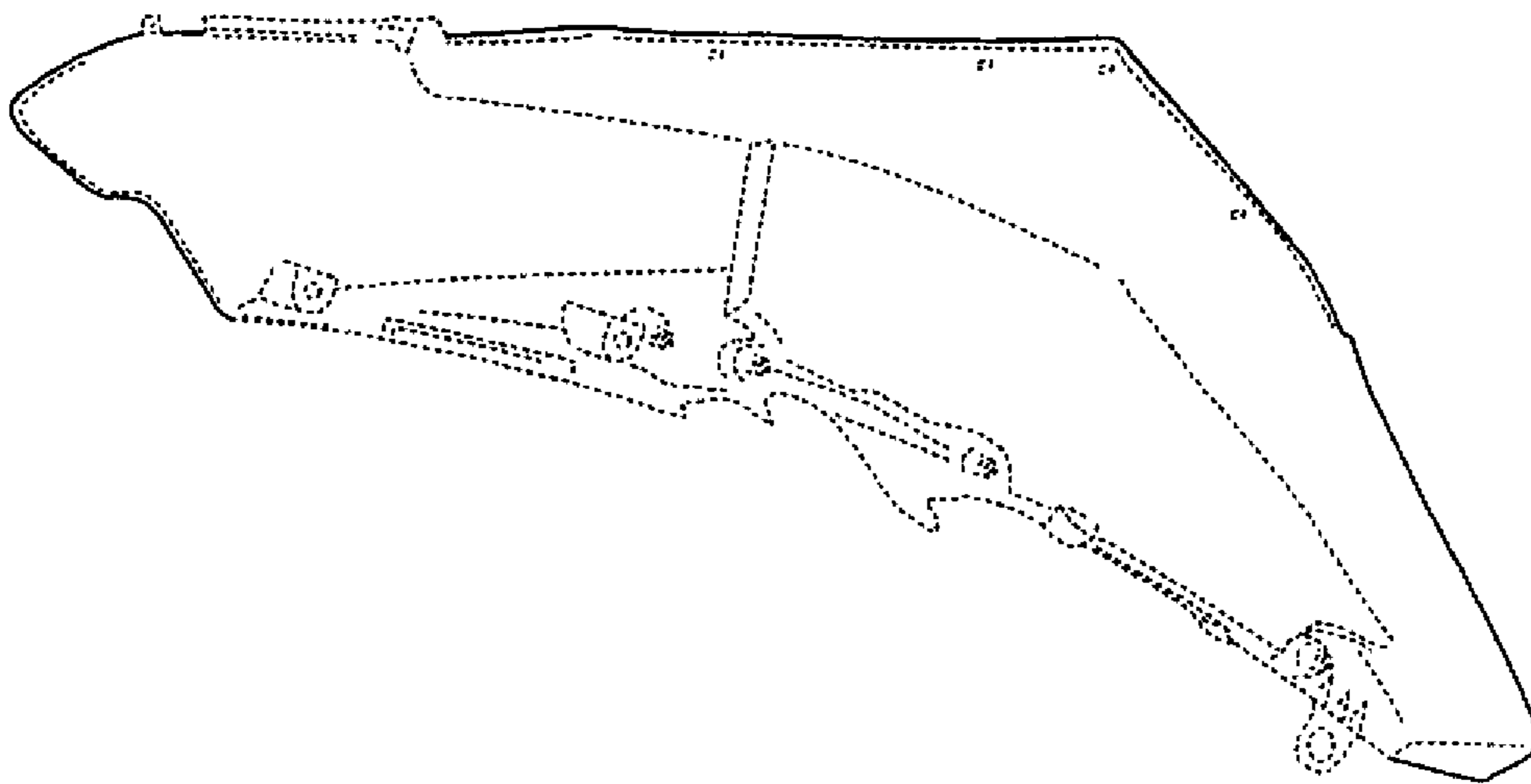

FIG. 3

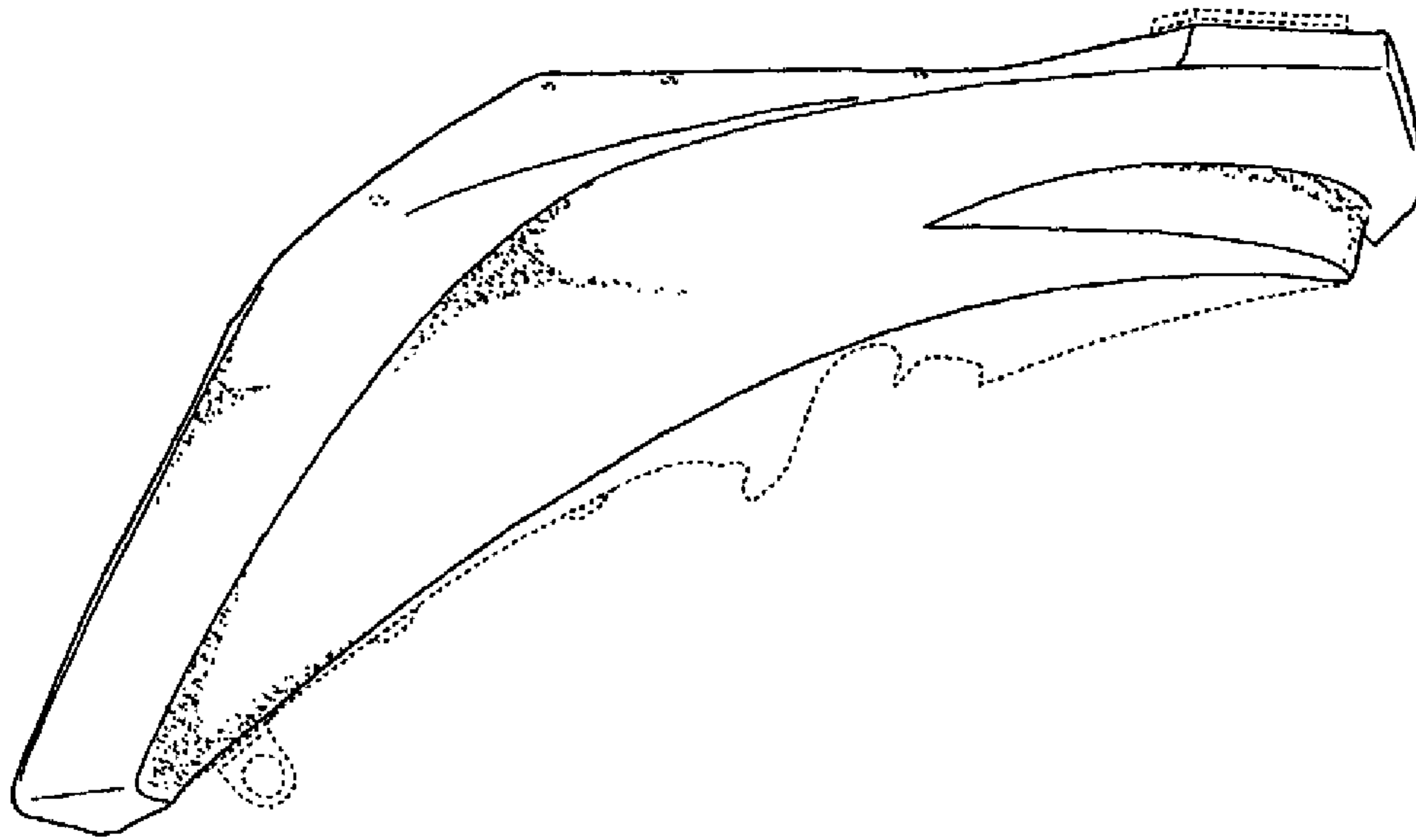

FIG. 4



FIG. 6

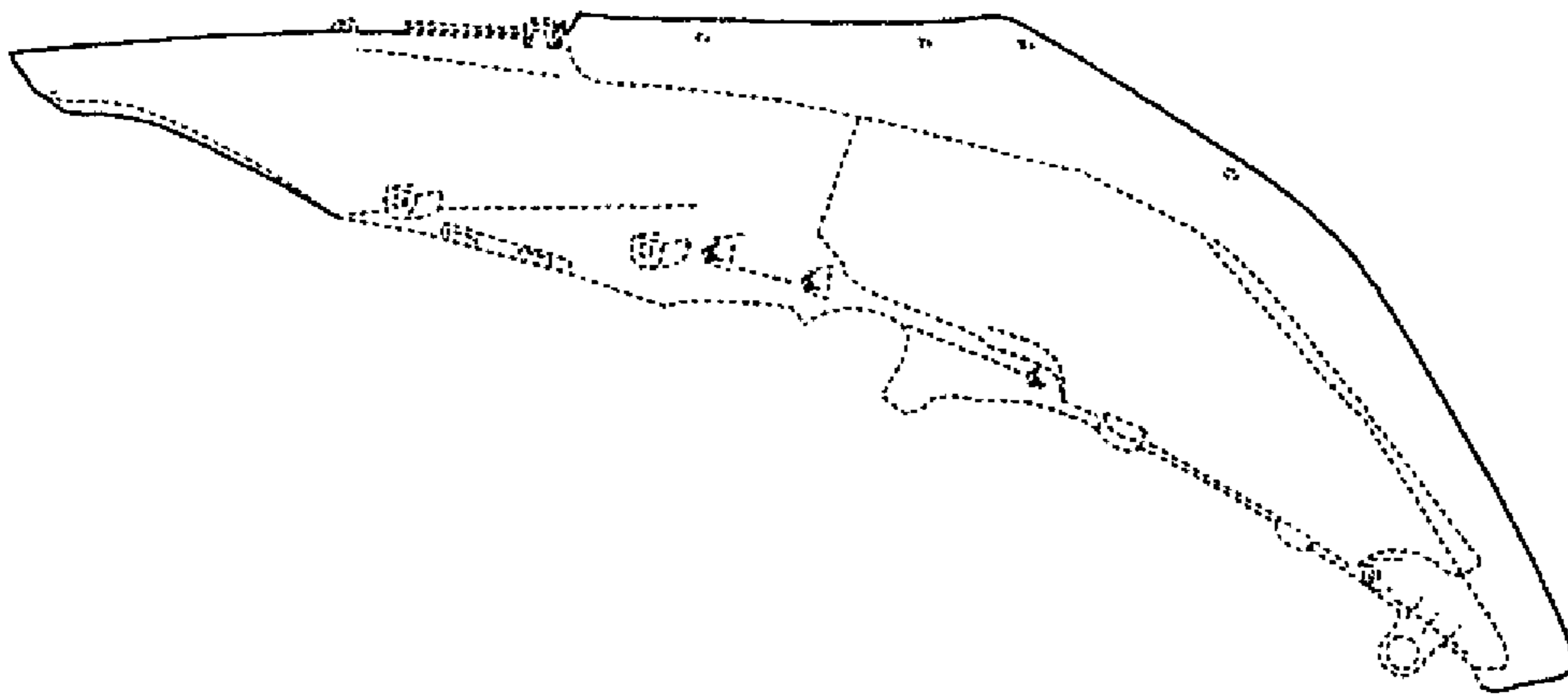

FIG. 8

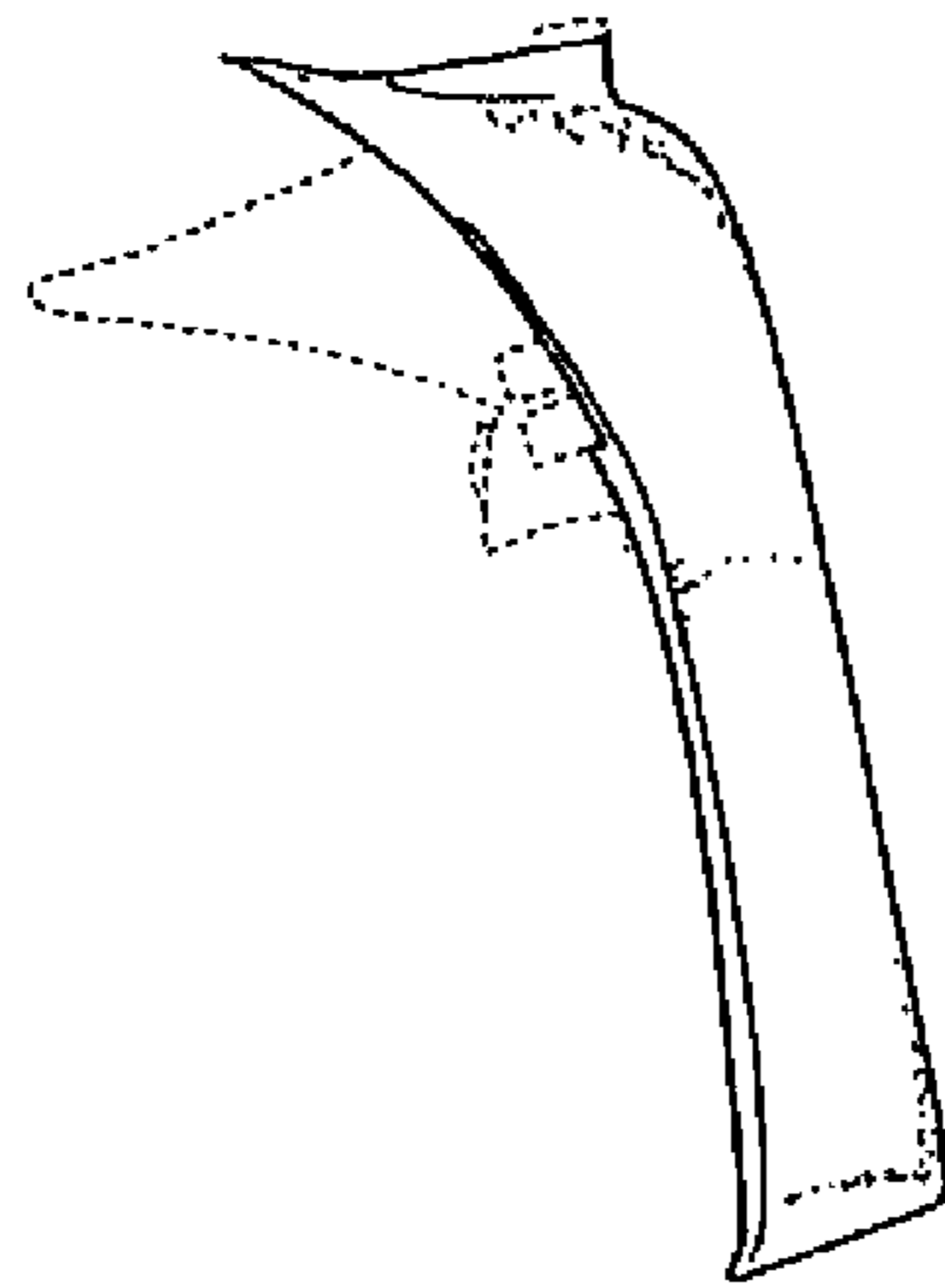

FIG. 9

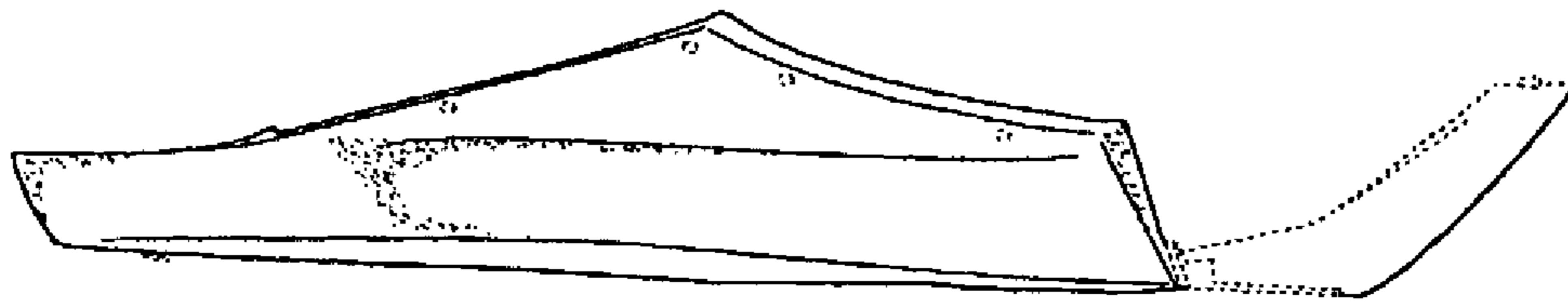
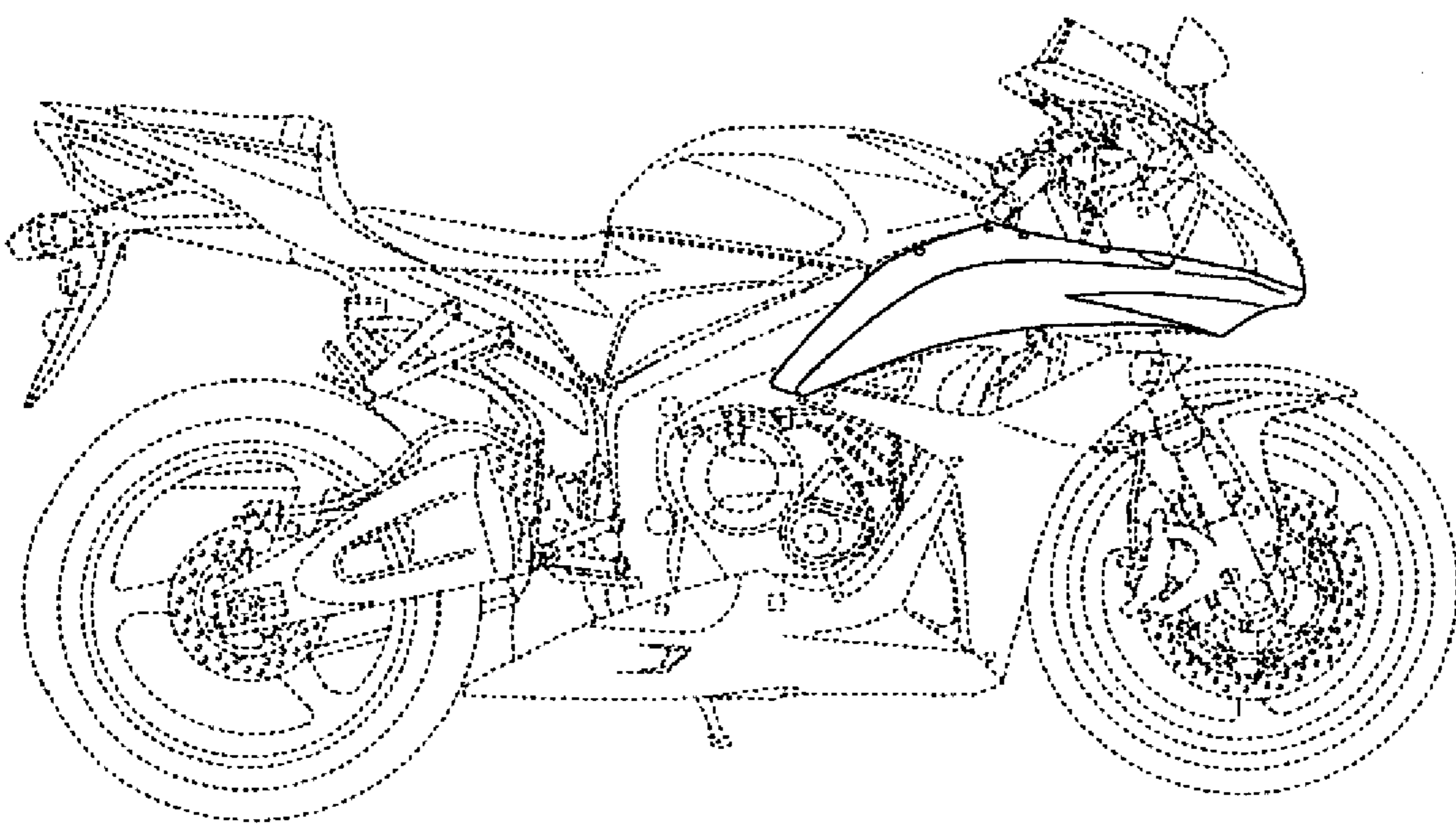

FIG. 11



UNITED STATES PATENT AND TRADEMARK OFFICE
CERTIFICATE OF CORRECTION

PATENT NO. : Des. 580,325 S
APPLICATION NO. : 29/266474
DATED : November 11, 2008
INVENTOR(S) : Sawabe et al.

Page 1 of 9

It is certified that error appears in the above-identified patent and that said Letters Patent is hereby corrected as shown below:

Title page illustrating a figure(s) should be deleted, and replaced with title page illustrating a figure(s). (attached)

Delete drawing sheets 2, 3, 4, 6, 8, 9 and 11, and replace with drawing sheets 2, 3, 4, 6, 8, 9 and 11. (attached)

Signed and Sealed this

Fifth Day of May, 2009



JOHN DOLL
Acting Director of the United States Patent and Trademark Office

(12) **United States Design Patent**
Sawabe et al.

(10) **Patent No.:** **US D580,325 S**
(45) **Date of Patent:** **** Nov. 11, 2008**

(54) **FRONT COWL FOR MOTORCYCLE**

Japanese Motorcycle Magazine, Jan. 1, 2006, p. 65 (www.motormagazine.co.jp).

(75) **Inventors:** **Akihiro Sawabe, Wako (JP); Hirotsugu Ueno, Wako (JP)**

* cited by examiner

(73) **Assignee:** **Honda Motor Co., Ltd., Tokyo (JP)**

Primary Examiner—Cathron Brooks

Assistant Examiner—Linda Brooks

(**) **Term:** **14 Years**

(74) *Attorney, Agent, or Firm*—Westerman, Hattori, Daniels & Adrian, L.L.P.

(21) **Appl. No.:** **29/266,474**

(57) **CLAIM**

(22) **Filed:** **Sep. 22, 2006**

The ornamental design for a front cowl for motorcycle, as shown and described.

(30) **Foreign Application Priority Data**

Mar. 23, 2006 (JP) 2006-007242

(51) **LOC (8) Cl.** **12-11**

(52) **U.S. Cl.** **D12/182; D12/126**

(58) **Field of Classification Search** D12/110, D12/112, 114, 182, 186; 280/288.4, 304.3, 280/152.1-152.3, 770, 848, 852; 180/219, 180/220, 225; 296/78.1, 180.1, 192, 193.01, 296/193.05, 193.09

See application file for complete search history.

DESCRIPTION

FIG. 1 is a perspective view from the right side of a front cowl for motorcycle.

FIG. 2 is a perspective view of the opposite side shown in FIG. 1.

FIG. 3 is a perspective view from the left side thereof.

FIG. 4 is a perspective view of the opposite side shown in FIG. 3.

FIG. 5 is a front elevation view thereof.

FIG. 6 is a rear elevation view thereof.

FIG. 7 is a right side elevation view thereof.

FIG. 8 is a left side elevation view thereof.

FIG. 9 is a top plan view thereof.

FIG. 10 is a bottom plan view thereof; and,

FIG. 11 is a view showing the claimed front cowl for motorcycle shown on a reduced scale and in position of use on a motorcycle, which is shown in broken lines and forms no part of the claimed design.

The portions shown in broken lines form no part of the claimed design.

(56) **References Cited**

U.S. PATENT DOCUMENTS

D500,464 S 1/2005 Ban et al.
D515,485 S * 2/2006 Sawabe et al. D12/182
D538,718 S * 3/2007 Tako et al. D12/182
D545,738 S * 7/2007 Tako et al. D12/182

OTHER PUBLICATIONS

Japanese Motorcycle Magazine, Feb. 1, 2006, pp. 84 and 85 (www.motormagazine.co.jp).

1 Claim, 11 Drawing Sheets

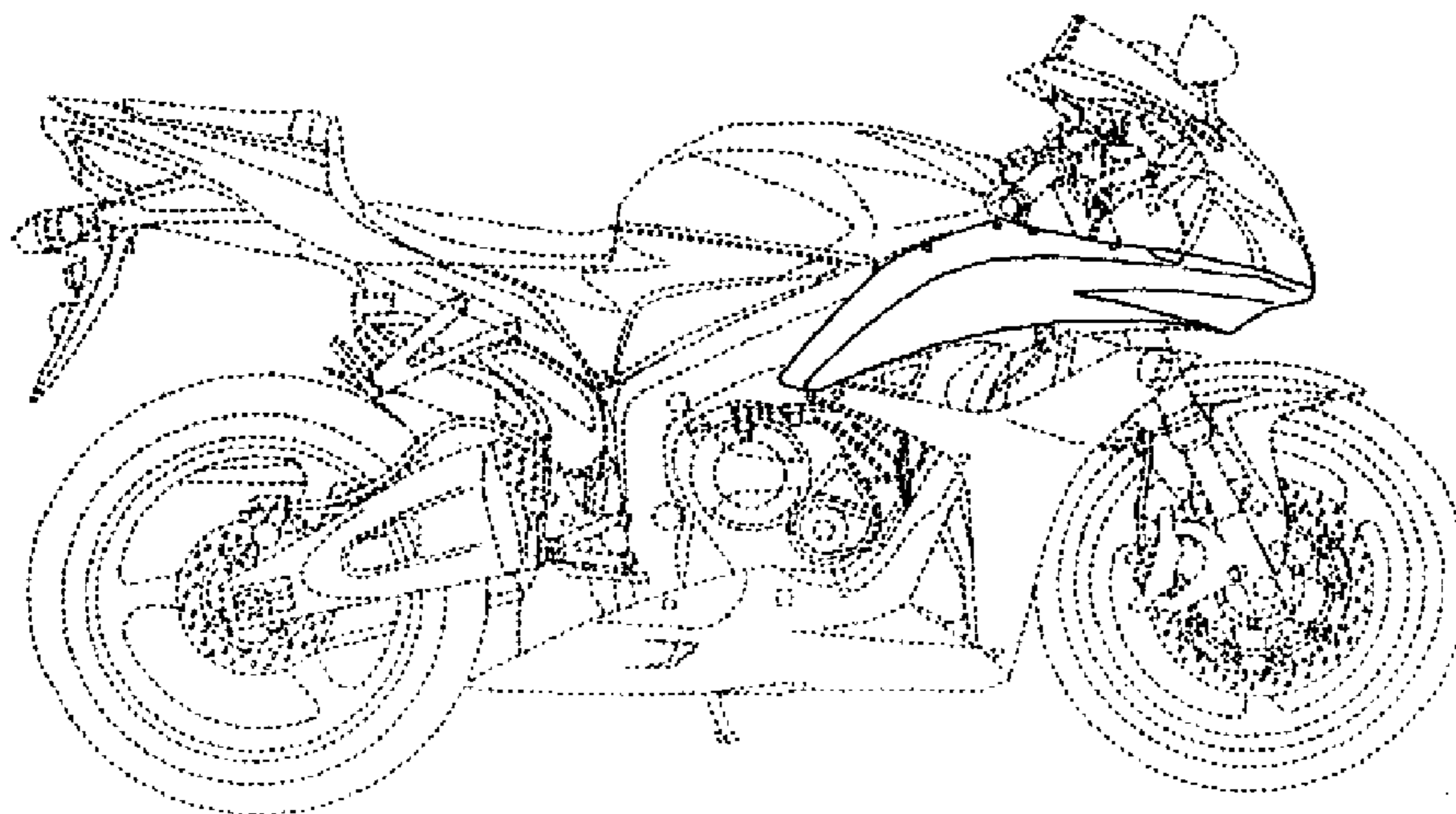

FIG. 2

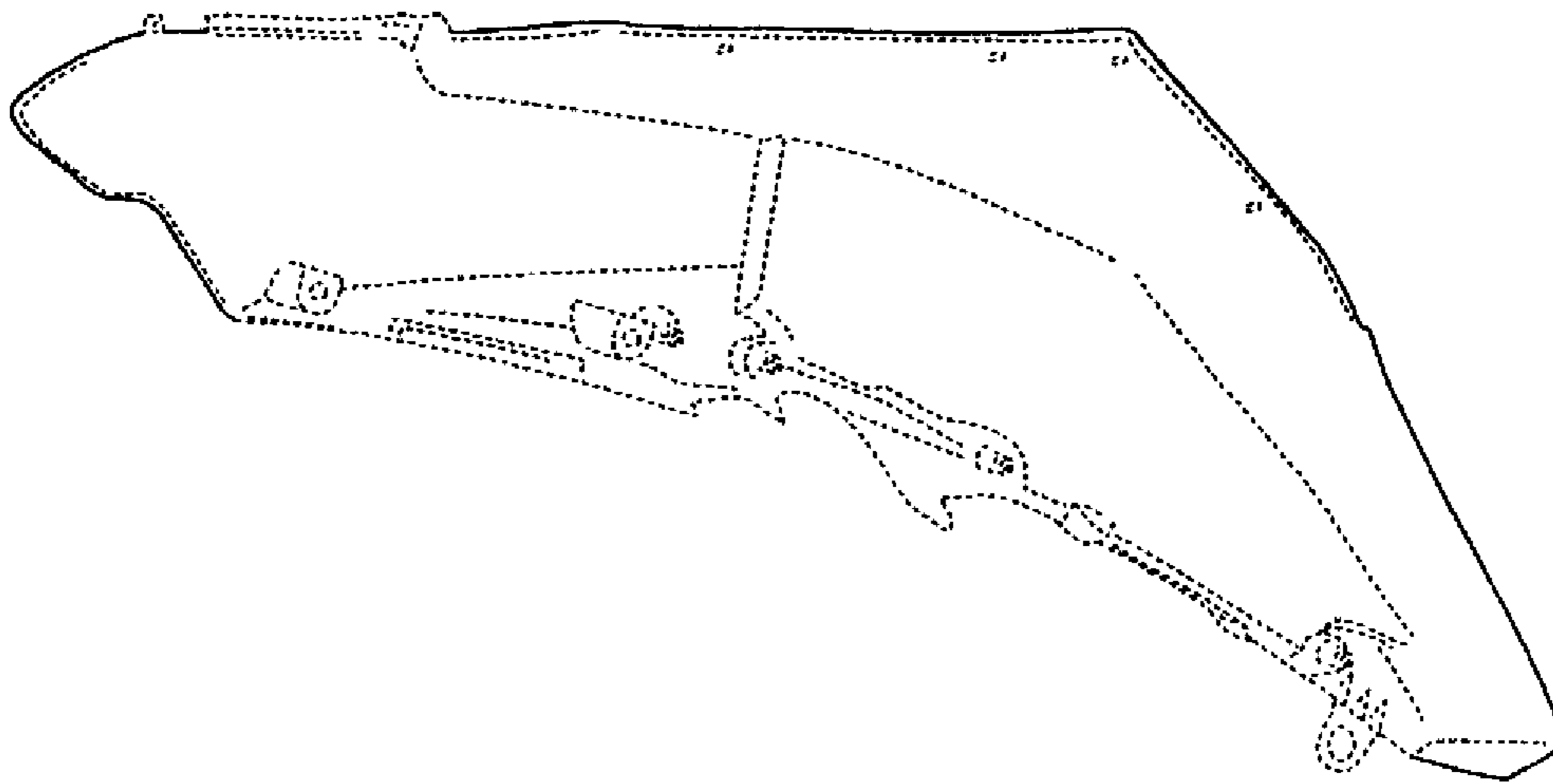

FIG. 3

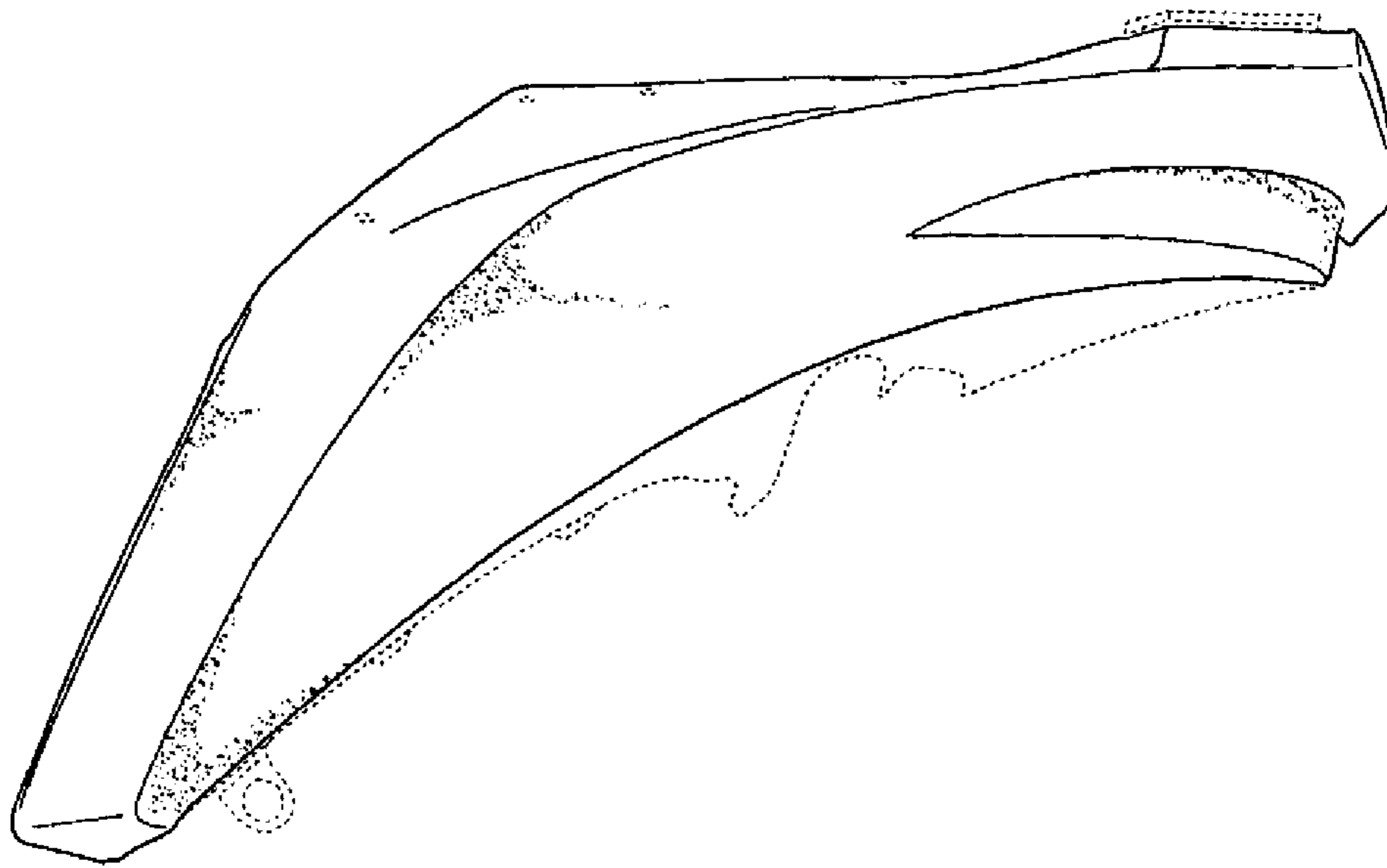

FIG. 4

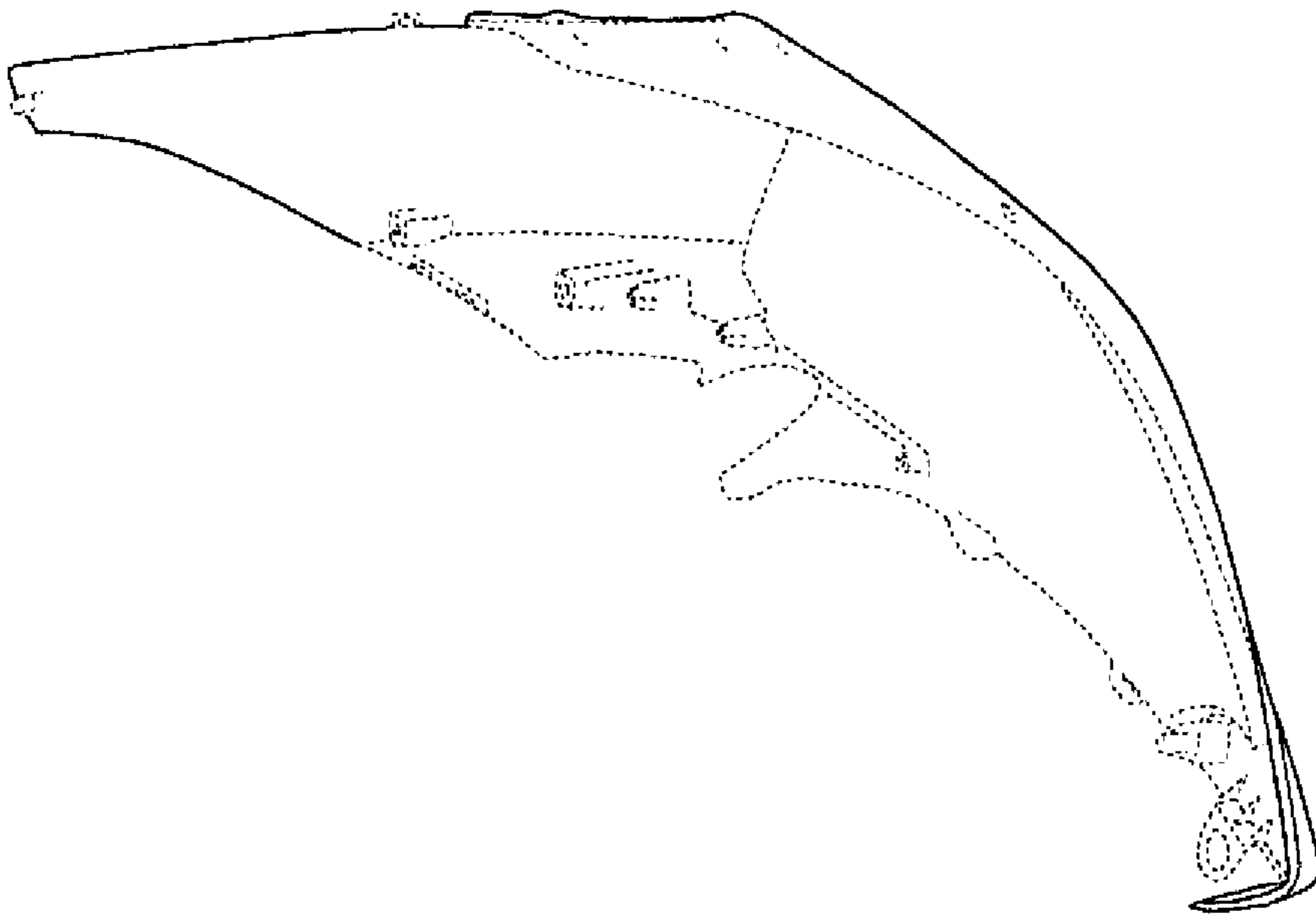

FIG. 6

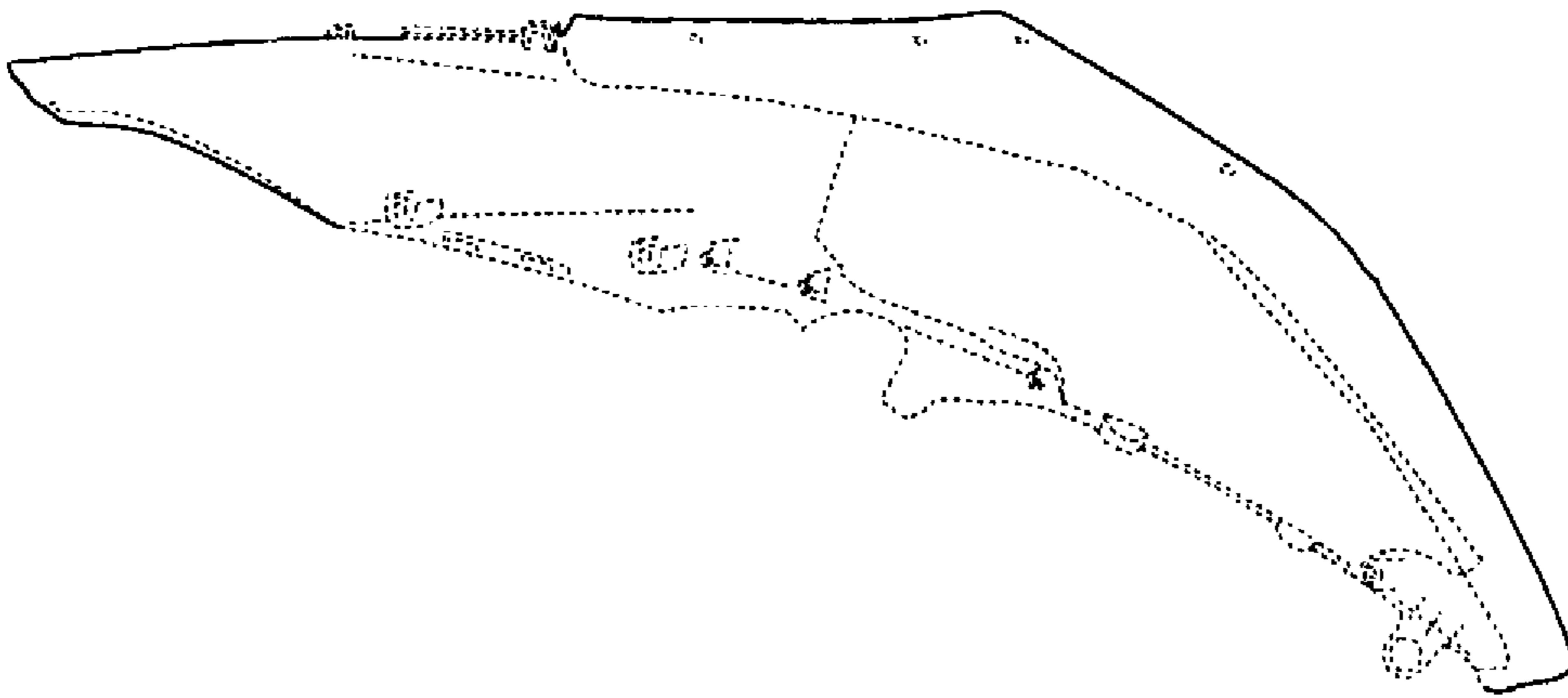

FIG. 8

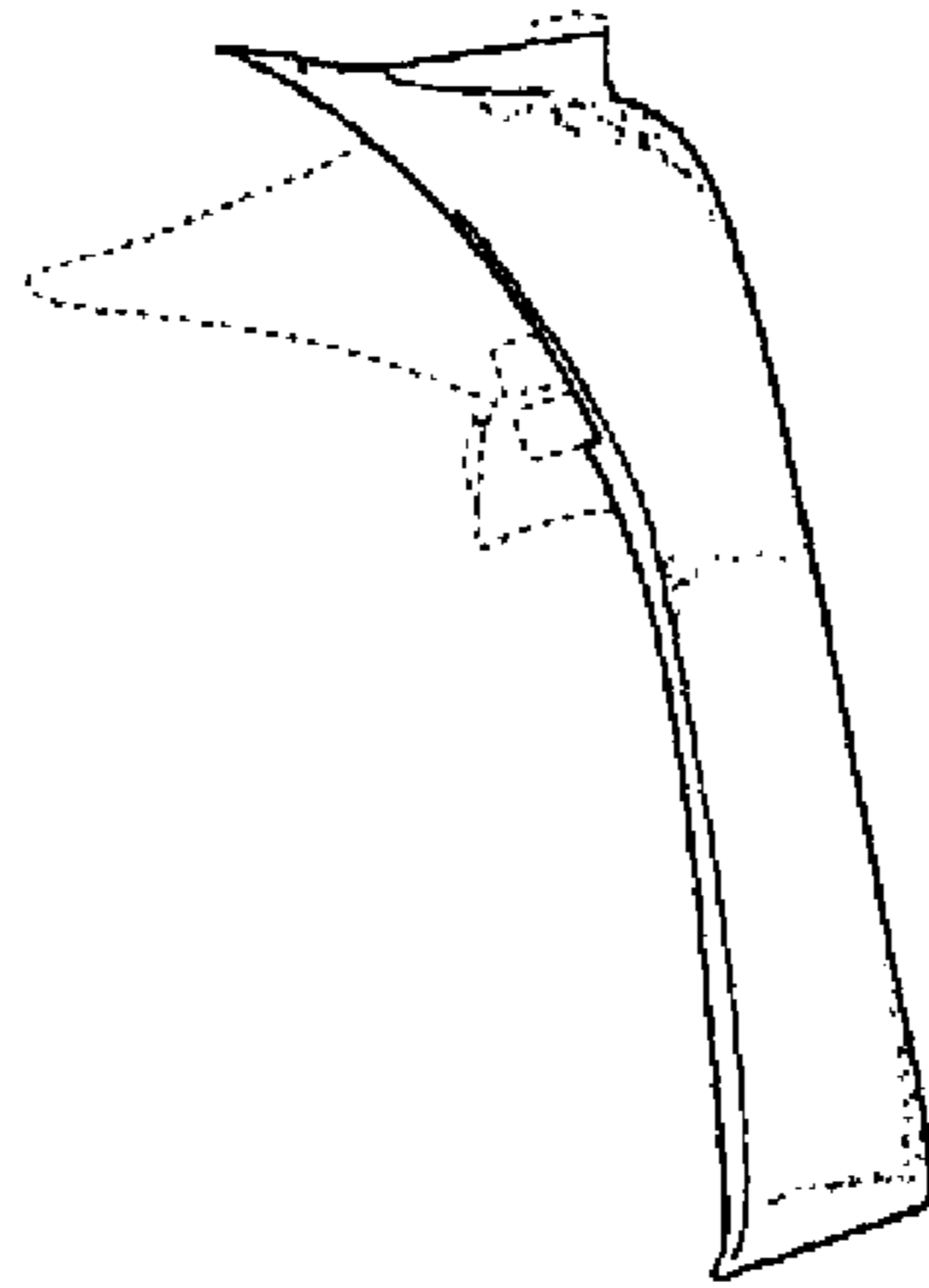
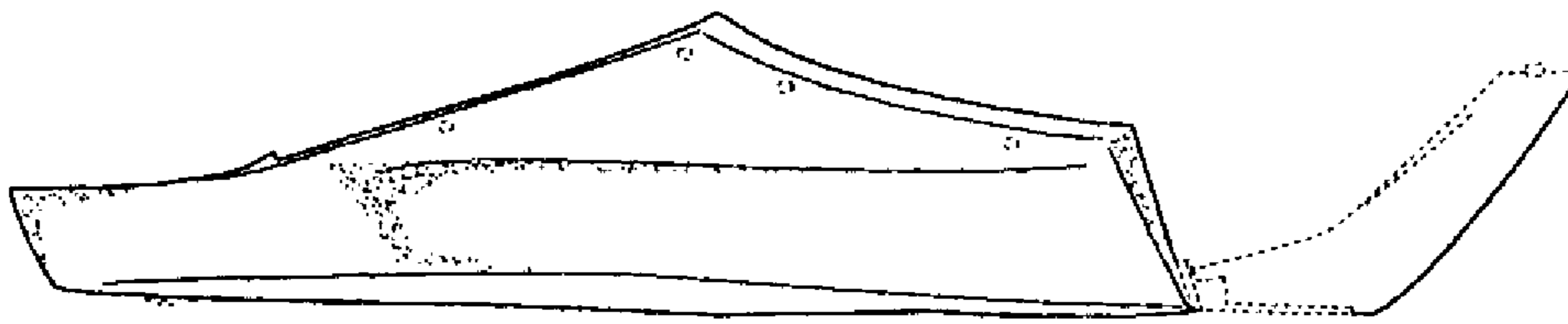

FIG. 9



UNITED STATES PATENT AND TRADEMARK OFFICE
CERTIFICATE OF CORRECTION

PATENT NO. : Des. 580,325 S
APPLICATION NO. : 29/266474
DATED : November 11, 2008
INVENTOR(S) : Akihiro Sawabe et al.

Page 1 of 1

It is certified that error appears in the above-identified patent and that said Letters Patent is hereby corrected as shown below:

This certificate vacates the Certificate of Correction issued May 5, 2009. The certificate is a duplicate of the Certificate of Correction issued April 14, 2009. All requested changes were included in the Certificate of Correction issued April 14, 2009.

Signed and Sealed this

Twenty-sixth Day of May, 2009



JOHN DOLL
Acting Director of the United States Patent and Trademark Office