



US00D580167S

(12) **United States Design Patent**  
**Jones**

(10) **Patent No.:** **US D580,167 S**

(45) **Date of Patent:** **\*\* Nov. 11, 2008**

(54) **CAMERA CASE**

D543,699 S \* 6/2007 Kuroda ..... D3/268

(75) Inventor: **Darren Jones**, American Fork, UT (US)

\* cited by examiner

(73) Assignee: **Alpine Innovations, LLC**, American Fork, UT (US)

*Primary Examiner*—Adir Aronovich  
*Assistant Examiner*—Anna J Burmeister

(\*\*) Term: **14 Years**

(74) *Attorney, Agent, or Firm*—Thorpe North & Western, LLP

(21) Appl. No.: **29/268,088**

(57) **CLAIM**

(22) Filed: **Oct. 24, 2006**

The ornamental design for a camera case, as shown and described.

(51) **LOC (8) Cl.** ..... **03-01**

(52) **U.S. Cl.** ..... **D3/267**

(58) **Field of Classification Search** ..... D3/201,  
D3/204, 232, 265, 267, 272–273, 294, 301;  
D16/211, 250; D17/20, 22, 99; 84/453;  
190/100, 900; 211/85.6; 224/910; 150/162  
See application file for complete search history.

**DESCRIPTION**

FIG. 1 is a bottom, front, and left side perspective view of a camera case, showing my new design;

FIG. 2 is a bottom, rear, and right side perspective view thereof;

FIG. 3 is a front elevational view thereof;

FIG. 4 is a rear elevational view thereof;

FIG. 5 is a left side elevational view thereof;

FIG. 6 is a right side elevational view thereof;

FIG. 7 is a bottom plan view thereof;

FIG. 8 is a top plan view thereof; and,

FIG. 9 is a bottom, rear, and right side perspective view thereof.

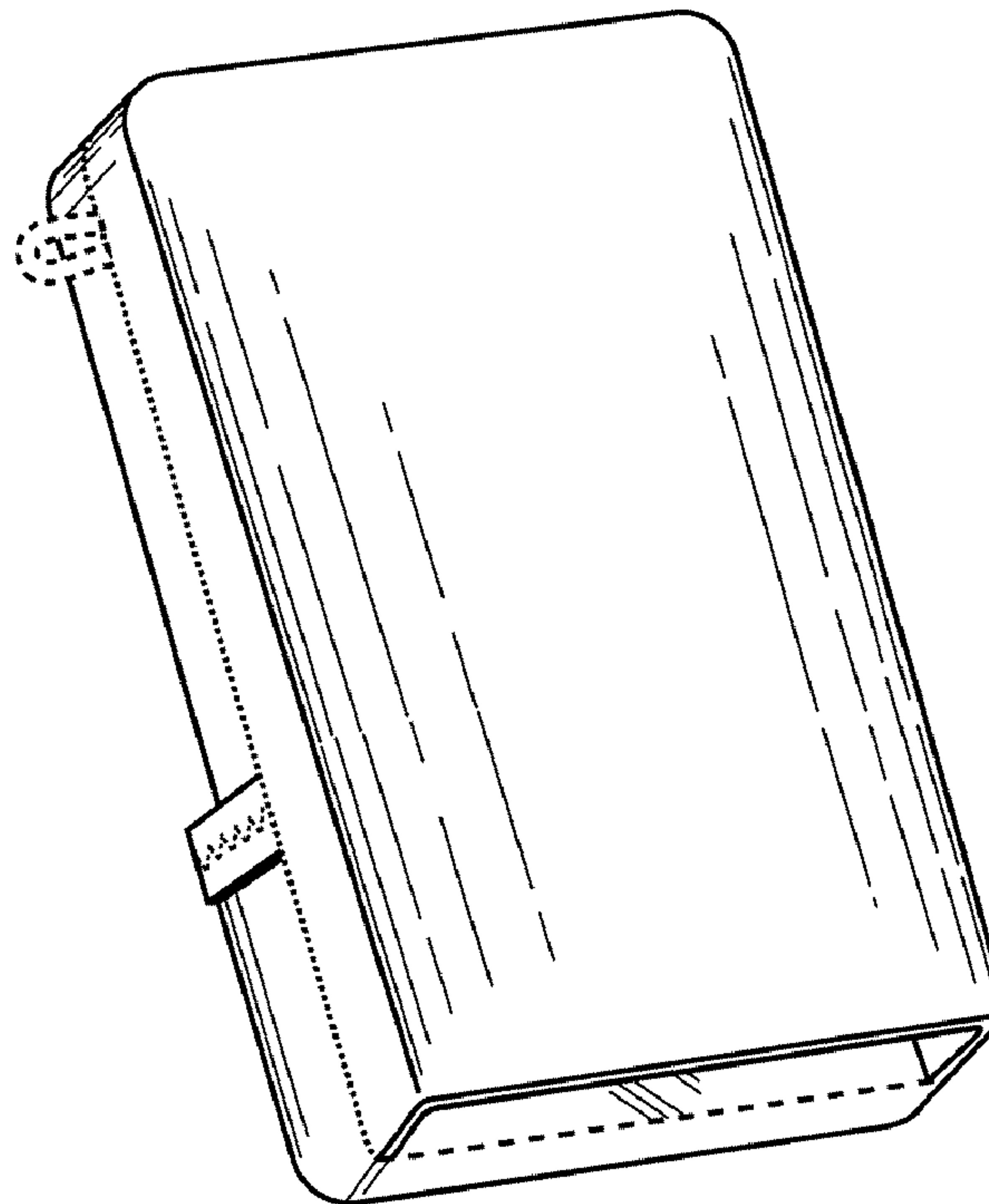
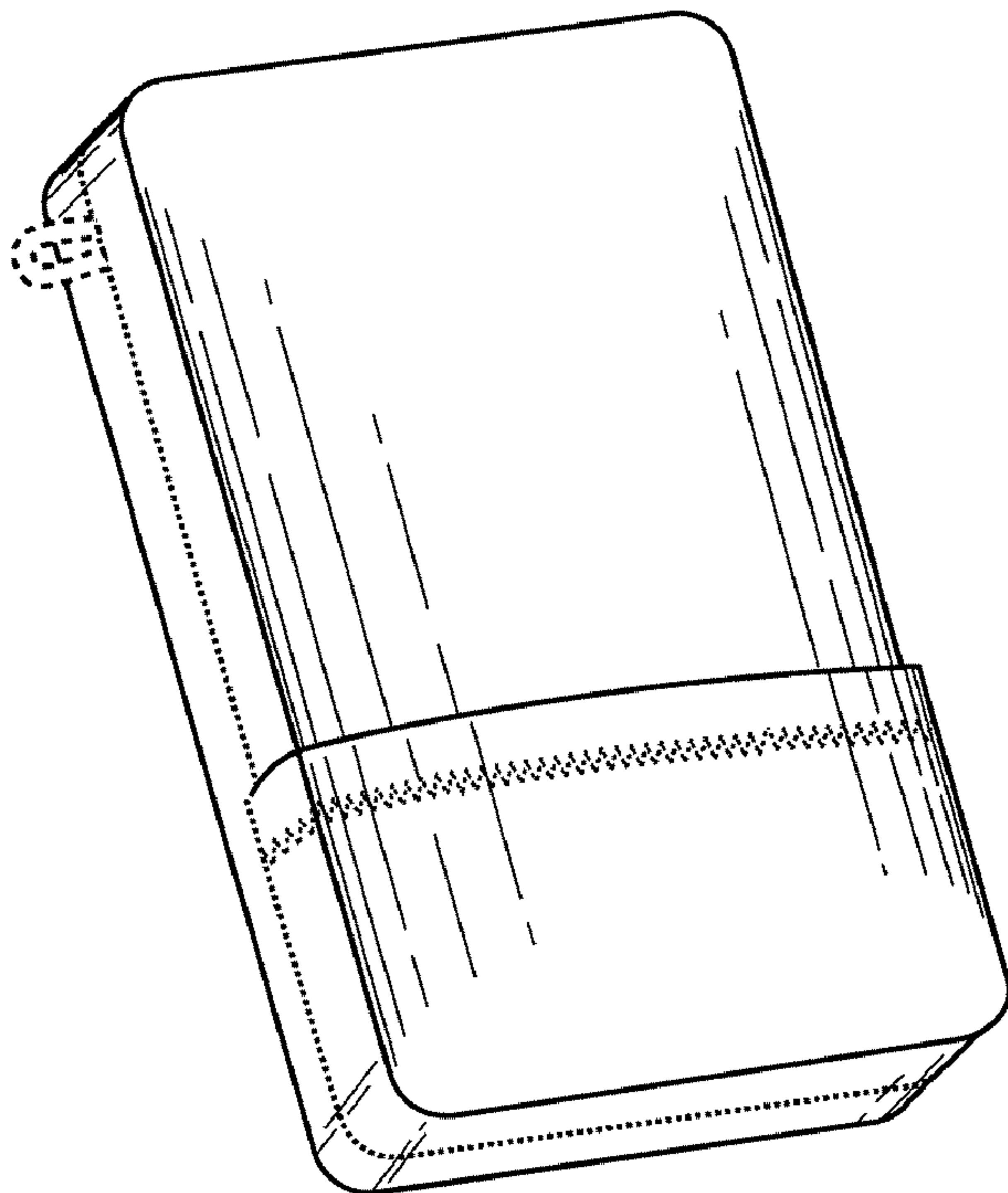
The broken lines shown in the drawings are for illustrative purposes only and form no part of the claimed design.

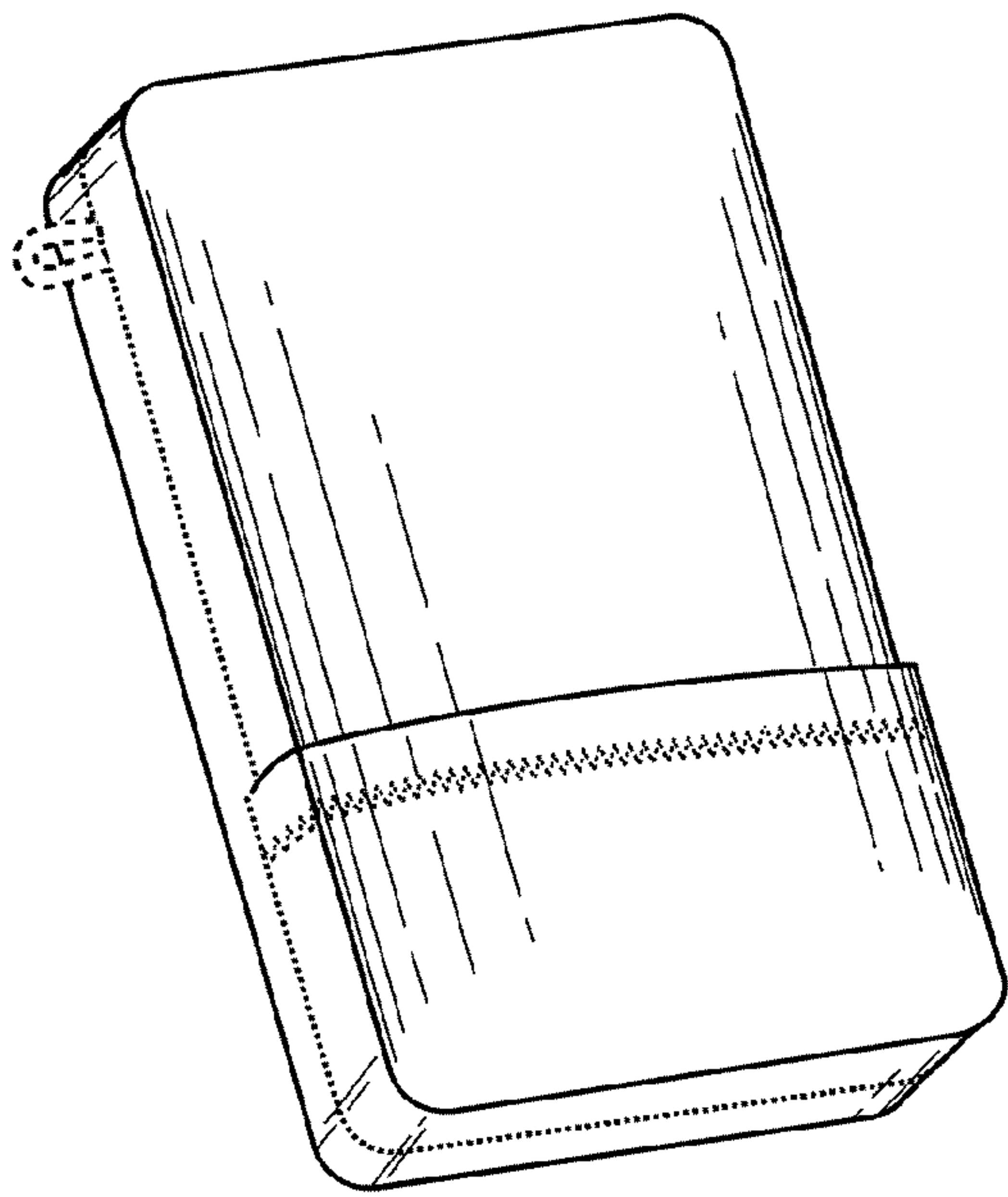
(56) **References Cited**

U.S. PATENT DOCUMENTS

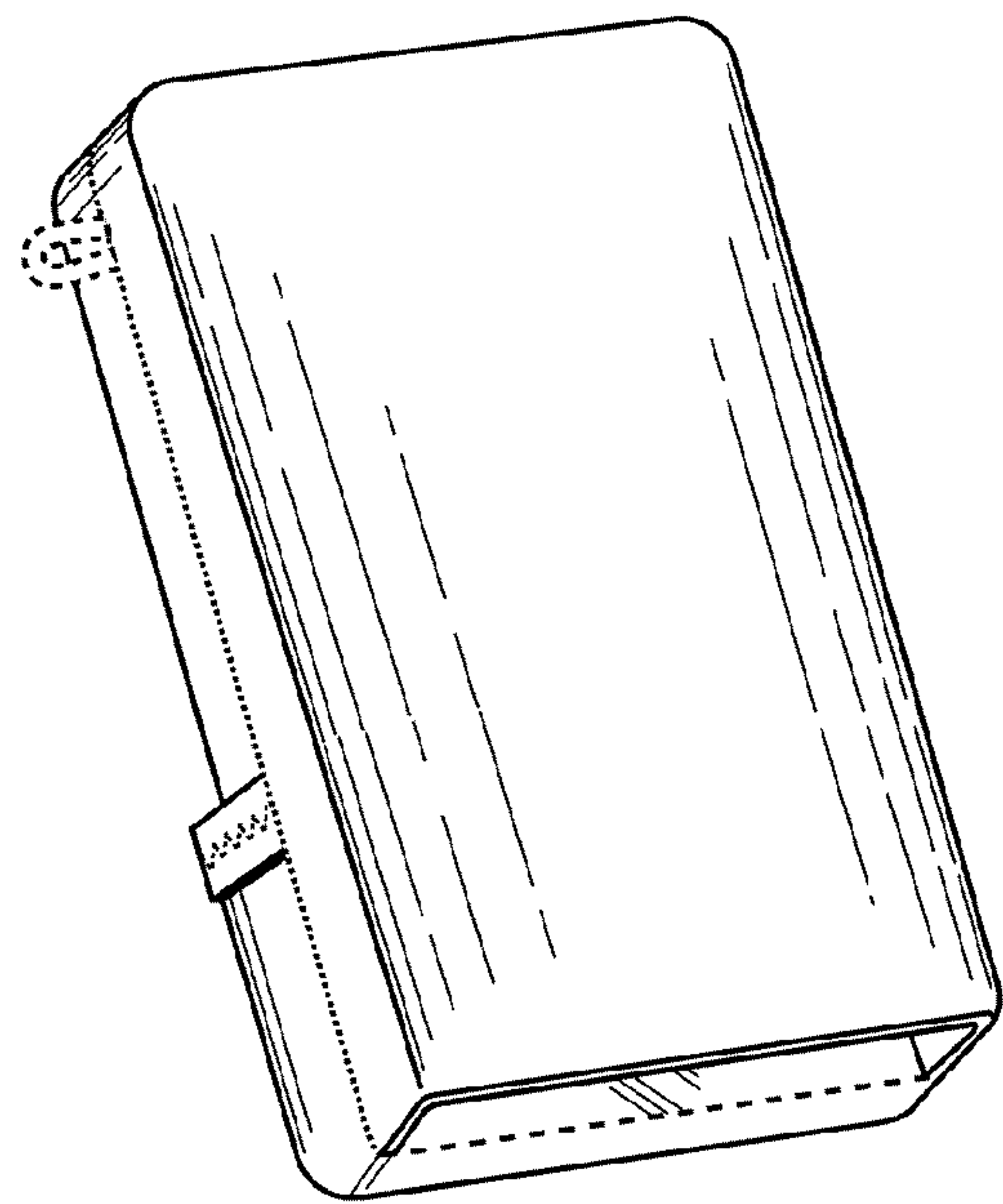
D125,522 S *	2/1941	Nathan	.....	D3/226
D220,233 S *	3/1971	Schurman	.....	D3/294
D294,081 S *	2/1988	Ito	.....	D3/219
D384,810 S *	10/1997	Kopel	.....	D3/226
6,536,589 B2 *	3/2003	Chang	.....	206/320
D476,149 S *	6/2003	Andre et al.	.....	D3/218
D482,866 S *	12/2003	Fair	.....	D3/267
D491,357 S *	6/2004	Hassett	.....	D3/267
D495,135 S *	8/2004	Hillman	.....	D3/267
D507,875 S *	8/2005	Hillman	.....	D3/267
D542,524 S *	5/2007	Richardson et al.	.....	D3/218

**1 Claim, 5 Drawing Sheets**

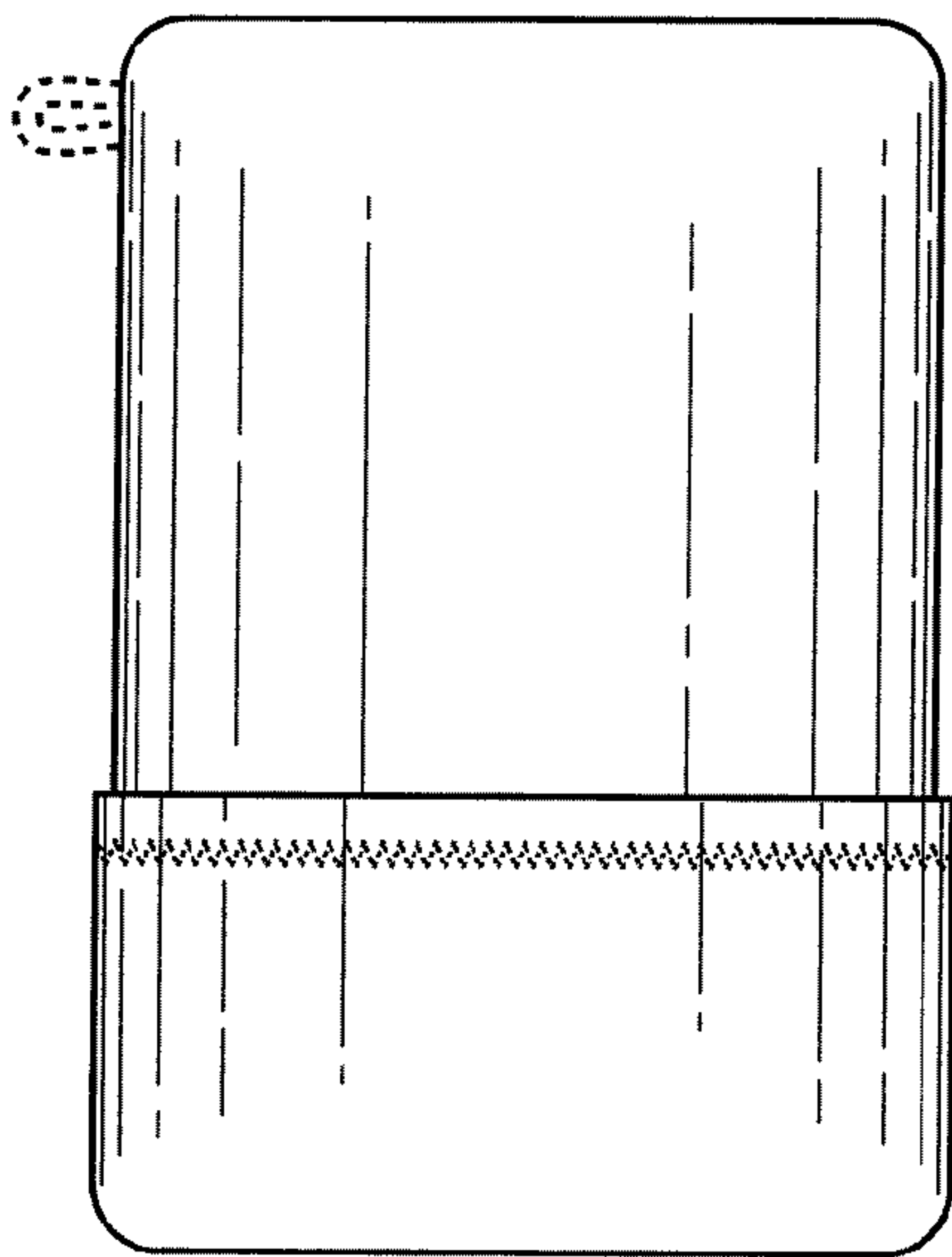




**Fig. 1**



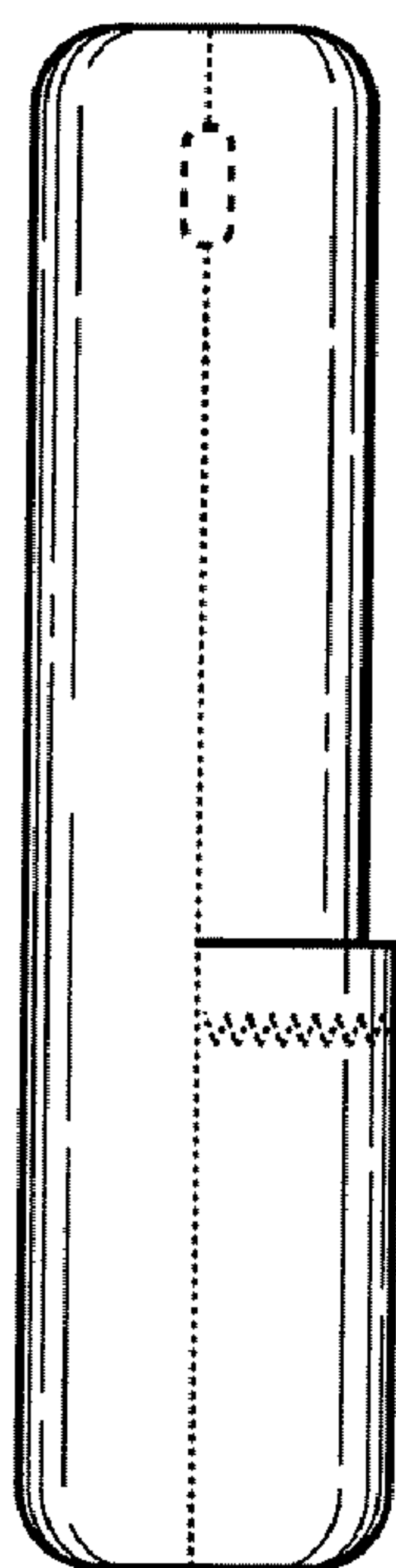
**Fig. 2**



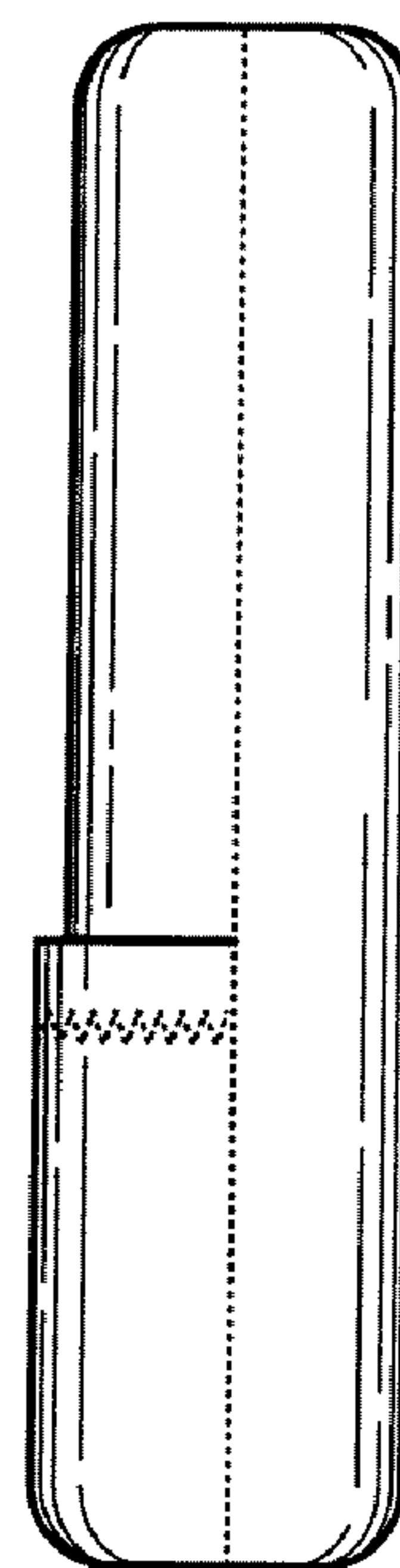
**Fig. 3**



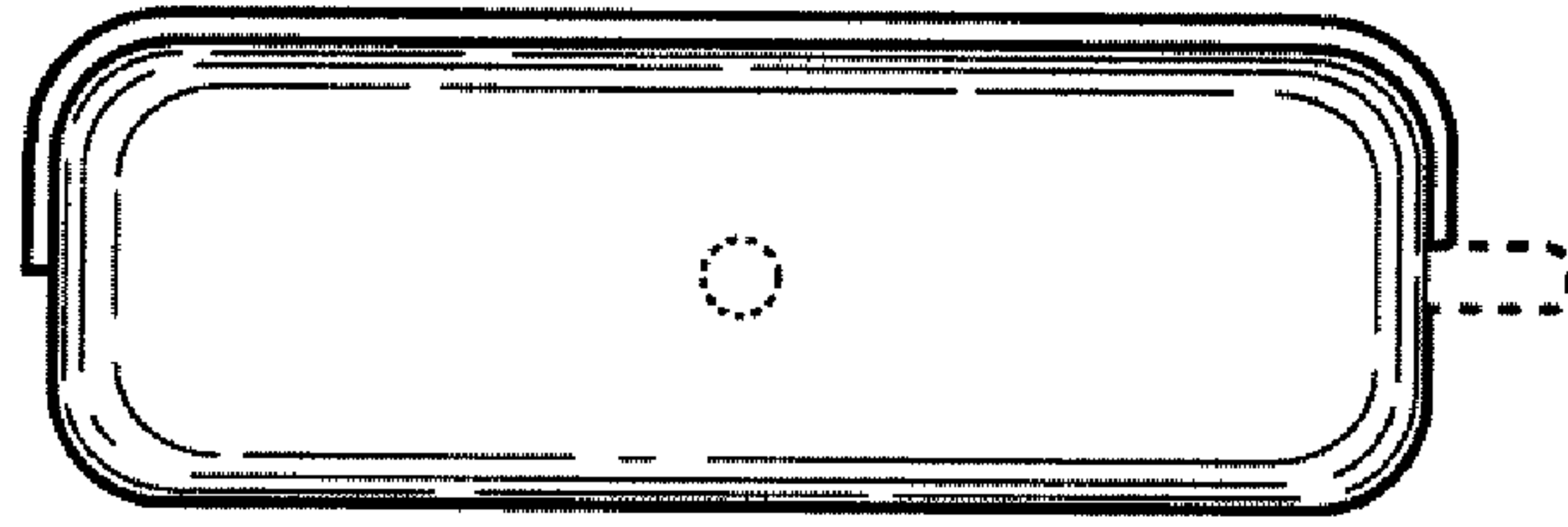
**Fig. 4**



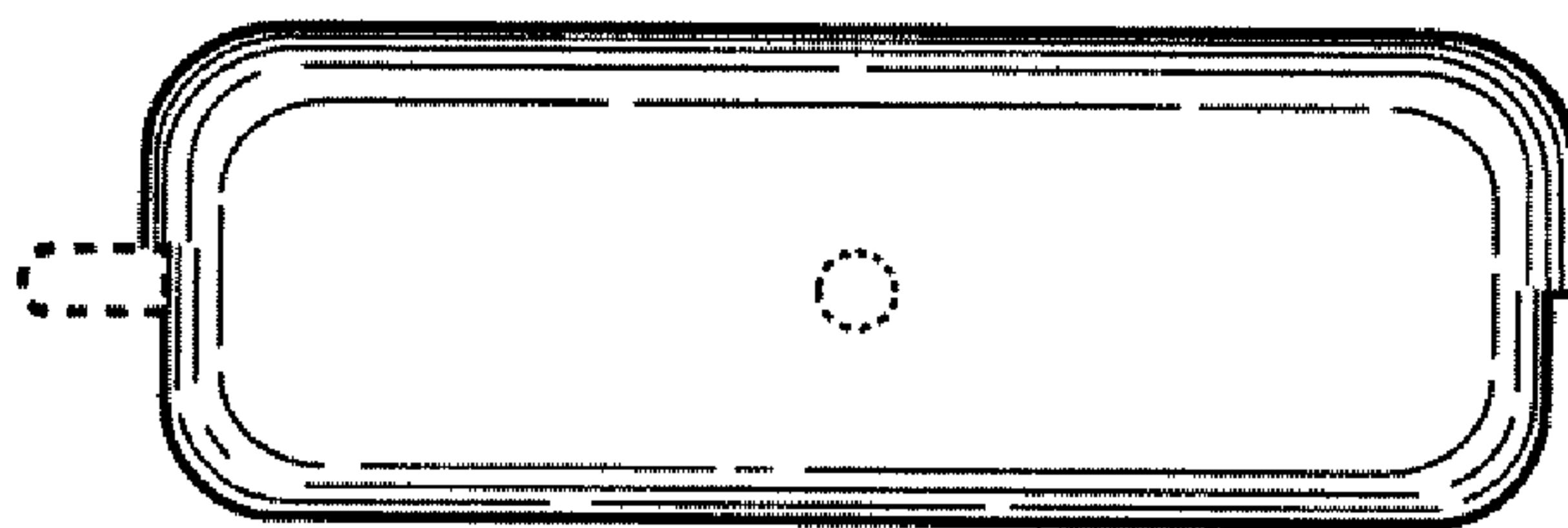
***Fig. 5***



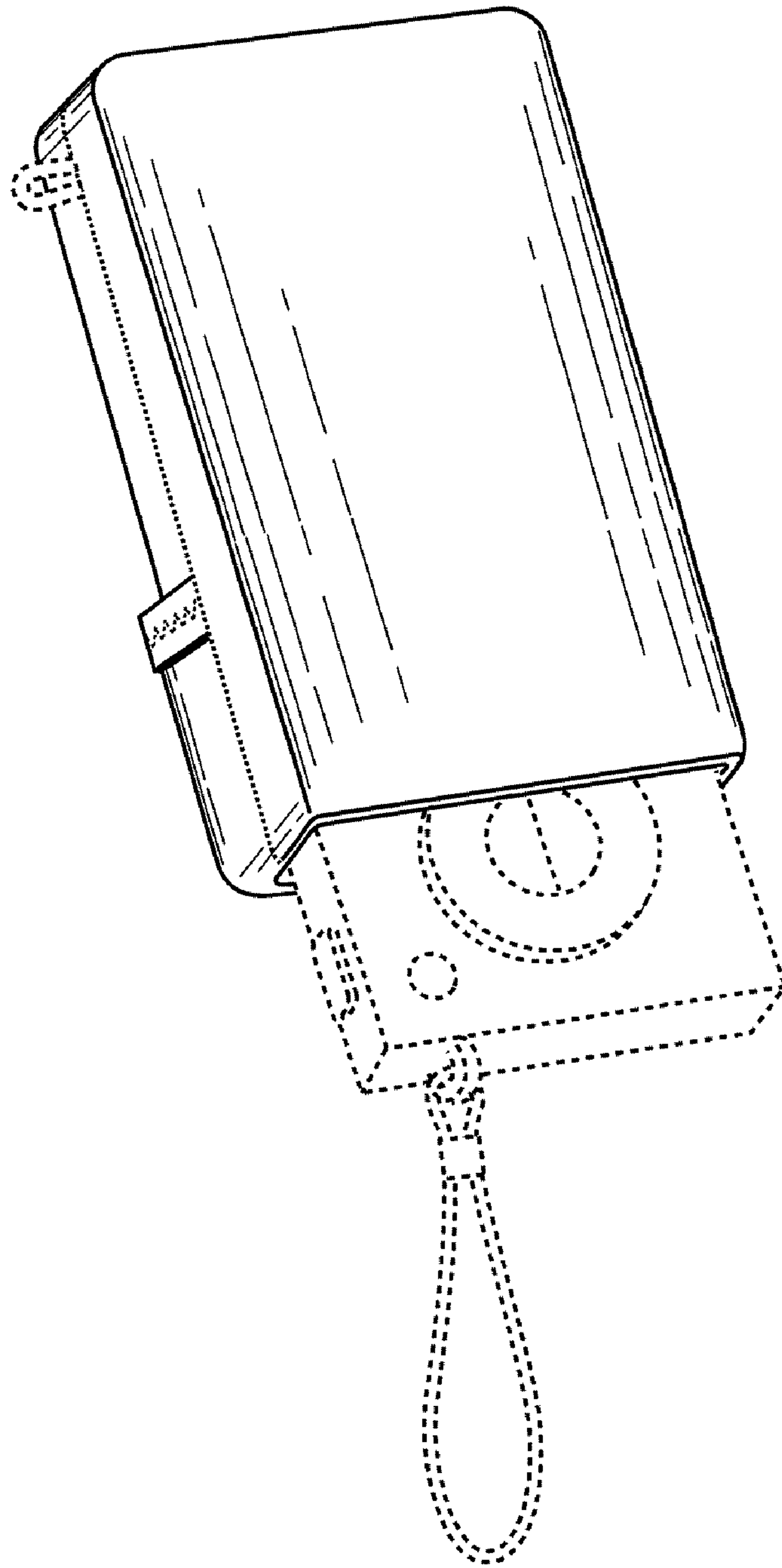
***Fig. 6***



***Fig. 7***



***Fig. 8***



**Fig. 9**