



US00D579679S

(12) **United States Design Patent**
Qian et al.

(10) **Patent No.:** **US D579,679 S**
(45) **Date of Patent:** **** Nov. 4, 2008**

(54) **CREEPER SEAT**

(76) Inventors: **Xiaodi Qian**, c/o Changshu Tongrun,
New Long Teng Industry Area, Changshu
Economy Development Zone, Changshu,
Jiangsu Province (CN); **Jianping Zhou**,
c/o Changshu Tongrun, New Long Teng
Industry Area, Changshu Economy
Development Zone, Changshu, Jiangsu
Province (CN); **Yufeng Qian**, c/o
Changshu Tongrun, New Long Teng
Industry Area, Changshu Economy
Development Zone, Changshu, Jiangsu
Province (CN)

6,733,073 B2 * 5/2004 Whiteside et al. 297/188.08
D511,416 S * 11/2005 Obbitts et al. D6/336
D530,108 S * 10/2006 Whiteside et al. D6/349
D555,920 S * 11/2007 Whiteside et al. D6/349

* cited by examiner

Primary Examiner—Sandra Snapp
(74) *Attorney, Agent, or Firm*—Ladas & Parry, LLP

(**) Term: **14 Years**

(21) Appl. No.: **29/289,300**

(22) Filed: **Jul. 13, 2007**

(51) **LOC (8) Cl.** **06-01**

(52) **U.S. Cl.** **D6/349**

(58) **Field of Classification Search** D6/349–353,
D6/355, 363, 364, 500–502, 511; 297/16.1,
297/118, 175, 195.1, 423.1, 423.14, 423.39,
297/423.41, 440.1, 440.12, 461, 462; 108/150
See application file for complete search history.

(56) **References Cited**

U.S. PATENT DOCUMENTS

4,832,355 A * 5/1989 Hung 280/32.5
D353,058 S * 12/1994 Dallas D6/336
D365,935 S * 1/1996 Dallas D6/336
D399,626 S * 10/1998 Taylor D34/23
D410,128 S * 5/1999 Dallas et al. D34/23
6,010,187 A * 1/2000 Dallas et al. 297/188.08
6,199,877 B1 * 3/2001 Shockley 280/32.6
D456,647 S * 5/2002 Whiteside et al. D6/498

(57) **CLAIM**

The ornamental design for the creeper seat, as shown and described.

DESCRIPTION

FIG. 1 is a perspective view of a first embodiment of a creeper seat showing our new design;

FIG. 2 is a top plan view of the first embodiment;

FIG. 3 is a bottom view of the first embodiment;

FIG. 4 is a rear view of the first embodiment;

FIG. 5 is a front view of the first embodiment;

FIG. 6 is a left side view of the first embodiment;

FIG. 7 is a right side view of the first embodiment;

FIG. 8 is a perspective view of a second embodiment of a creeper seat showing our new design;

FIG. 9 is a top plan view of the second embodiment;

FIG. 10 is a bottom view of the second embodiment;

FIG. 11 is a rear view of the second embodiment;

FIG. 12 is a front view of the second embodiment;

FIG. 13 is a left side view of the second embodiment; and,

FIG. 14 is a right side view of the second embodiment.

The broken lines in the drawings are for illustrative purposes only and form no part of the claimed design.

1 Claim, 8 Drawing Sheets

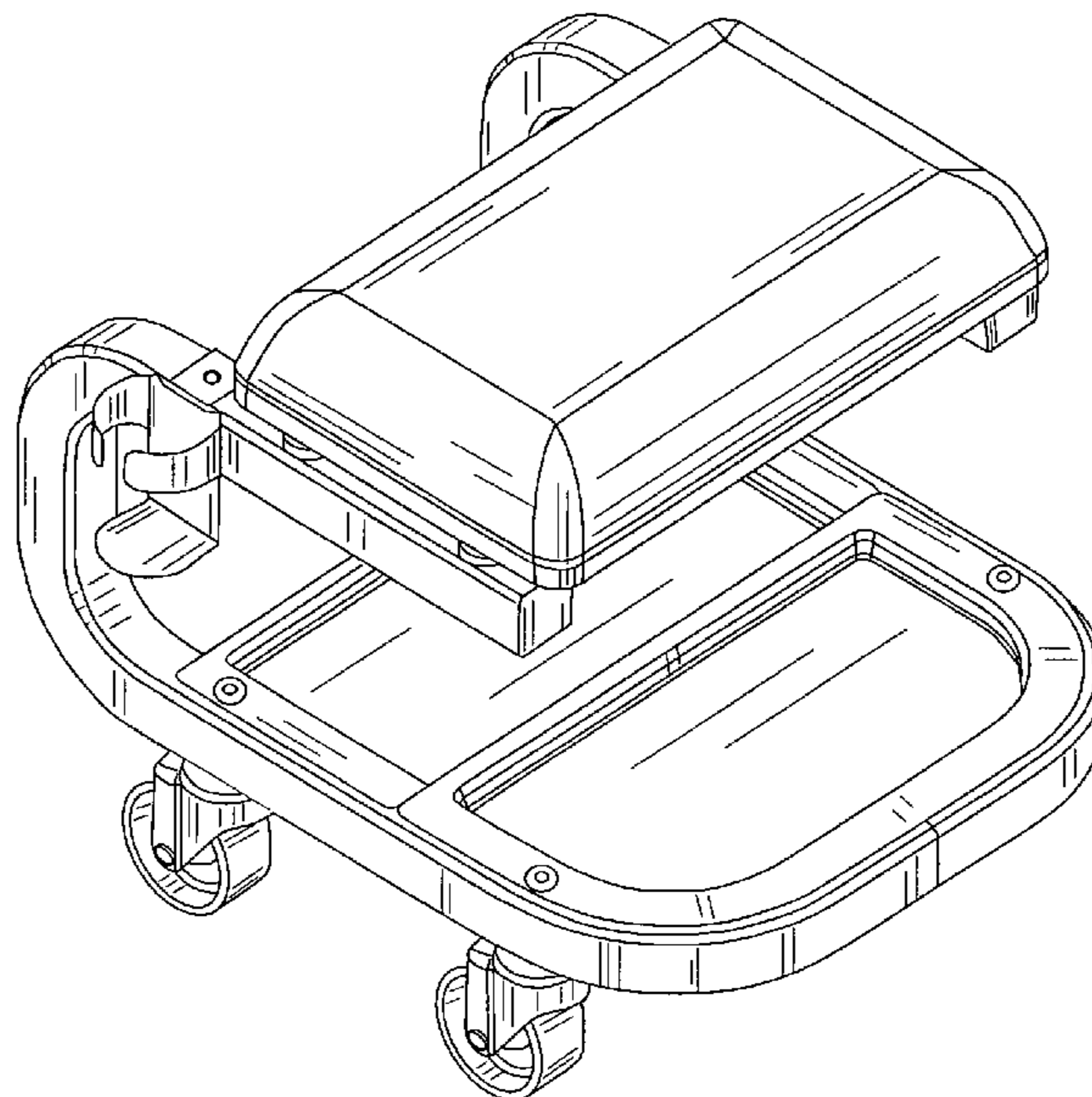

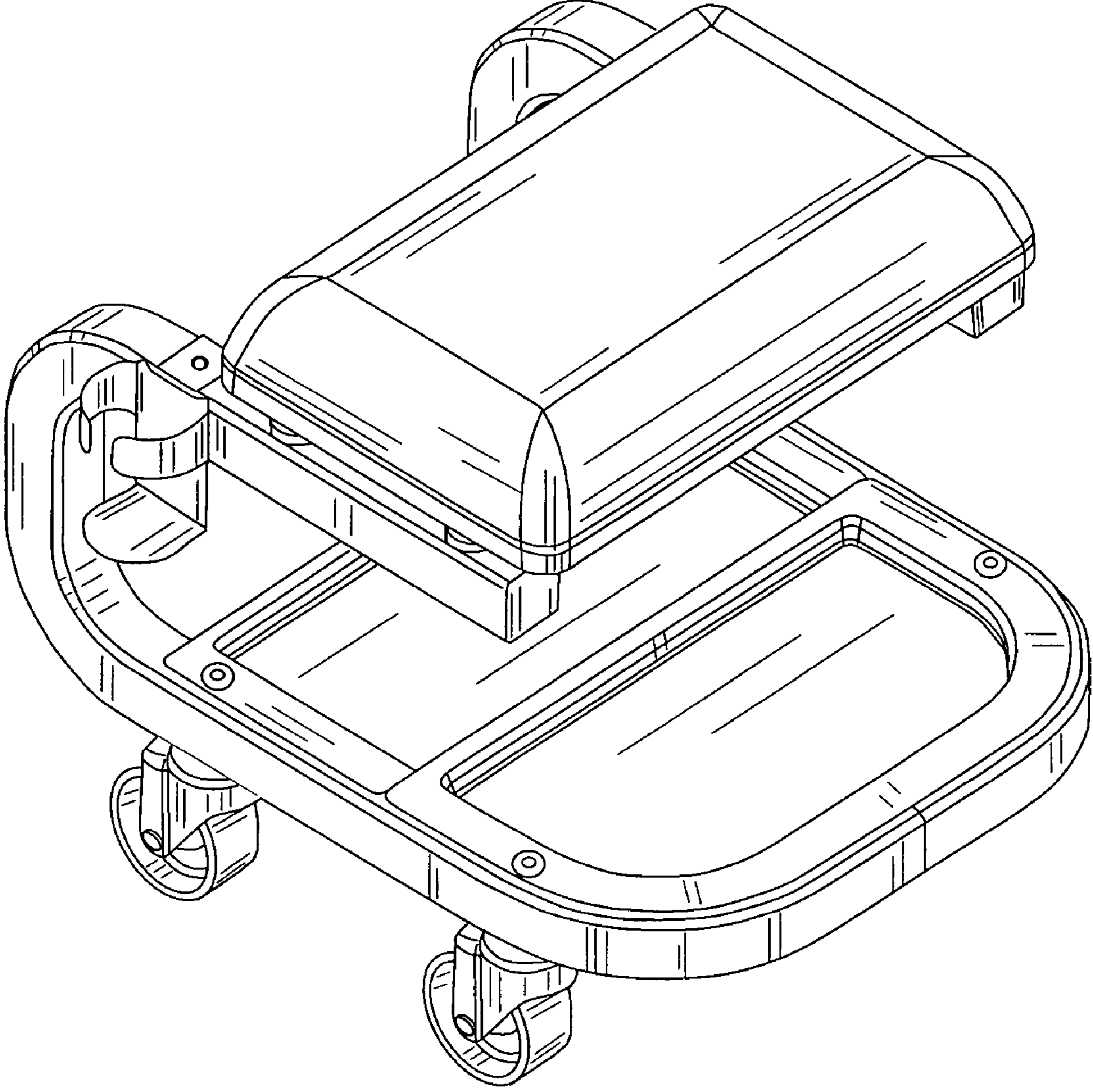

FIG. 1

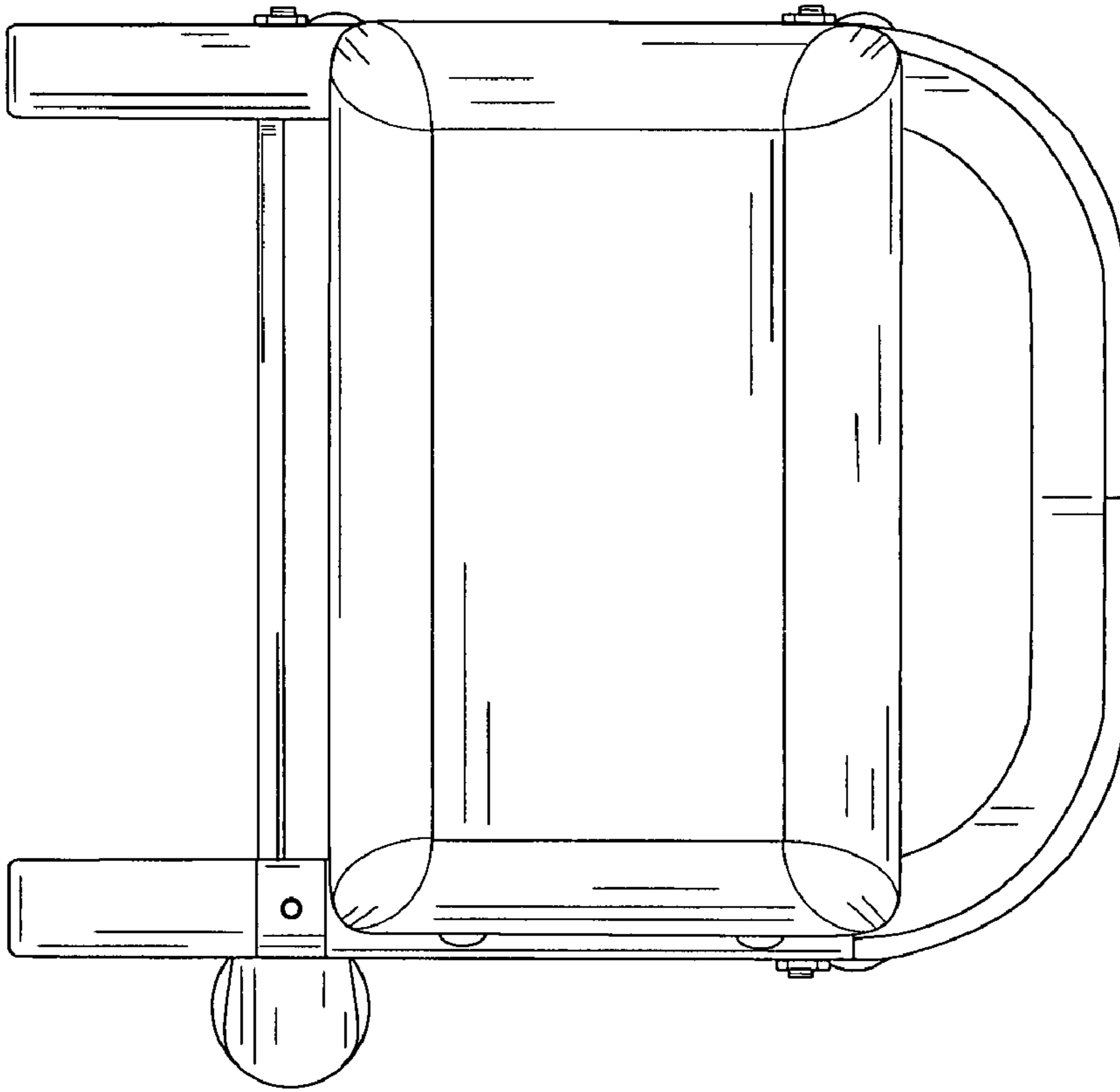

FIG. 2

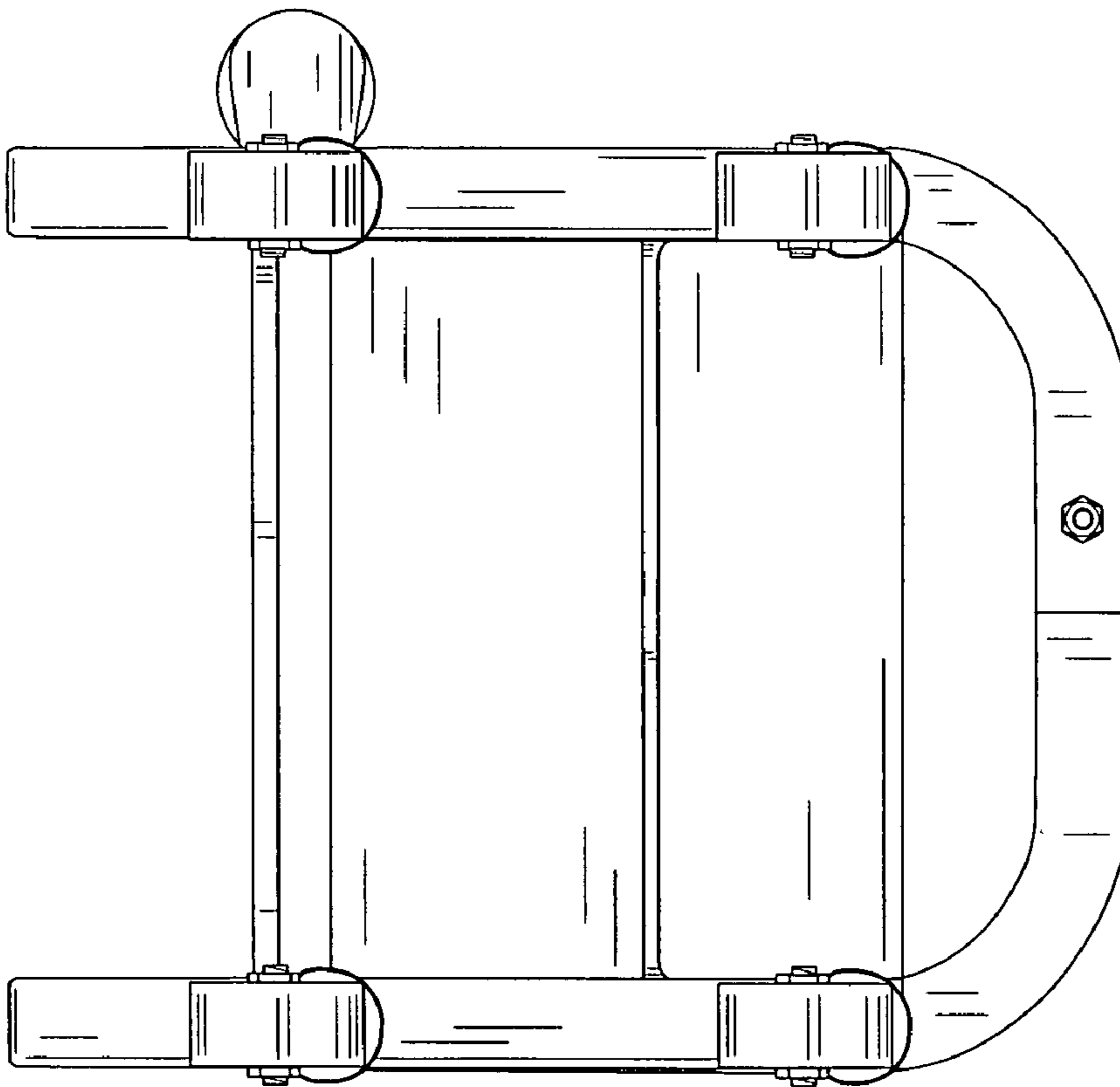

FIG. 3

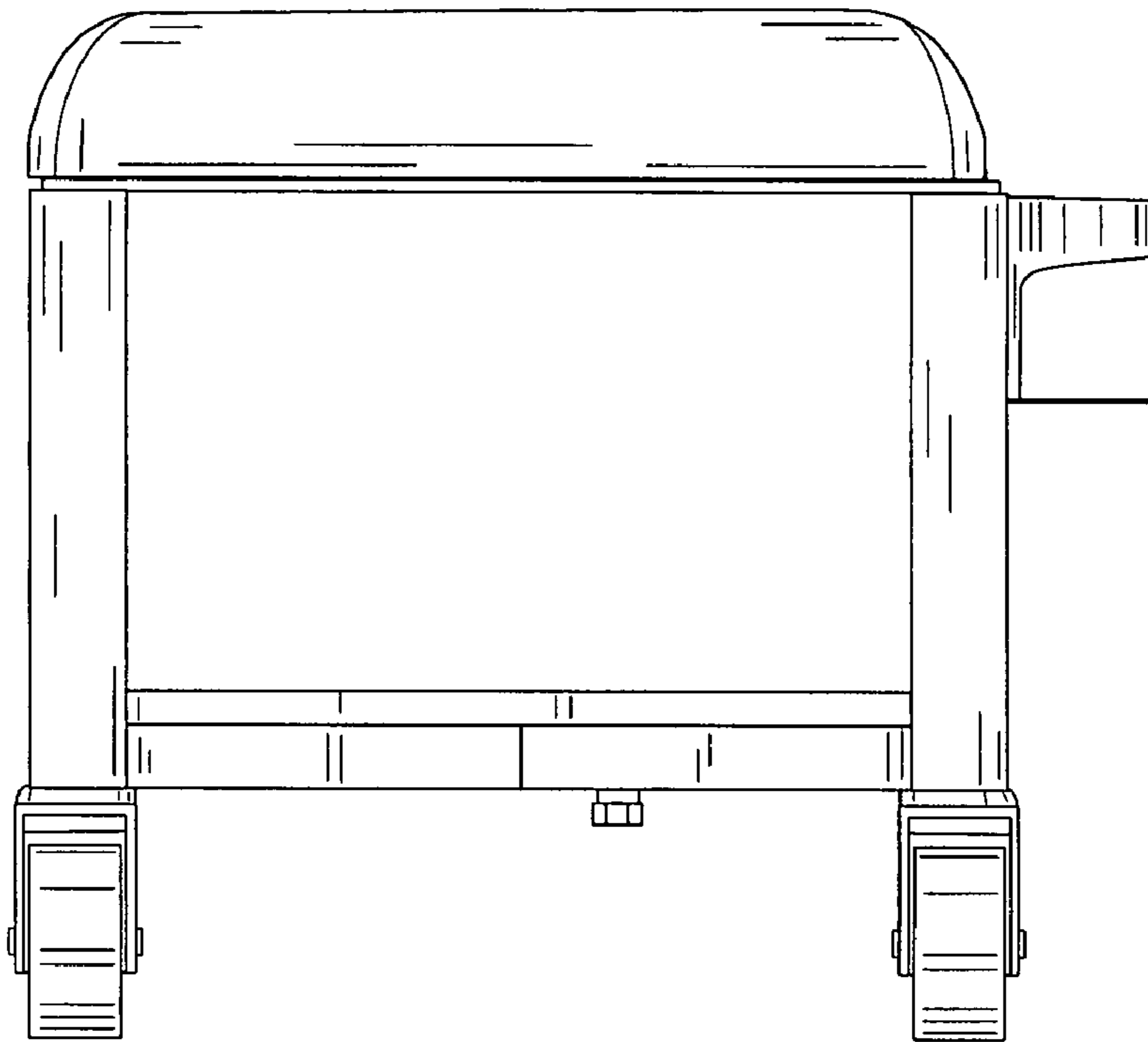

FIG. 4

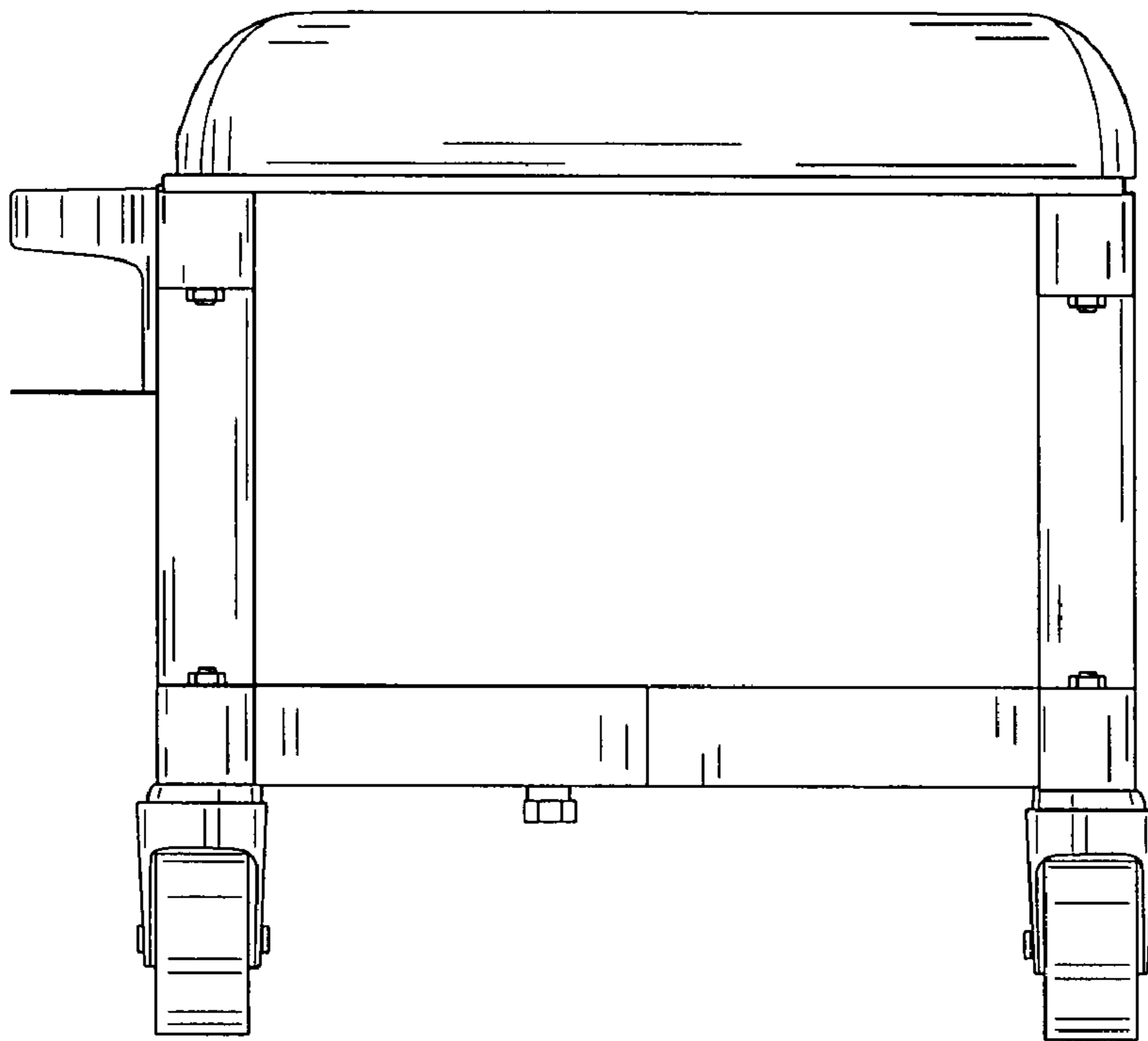

FIG. 5

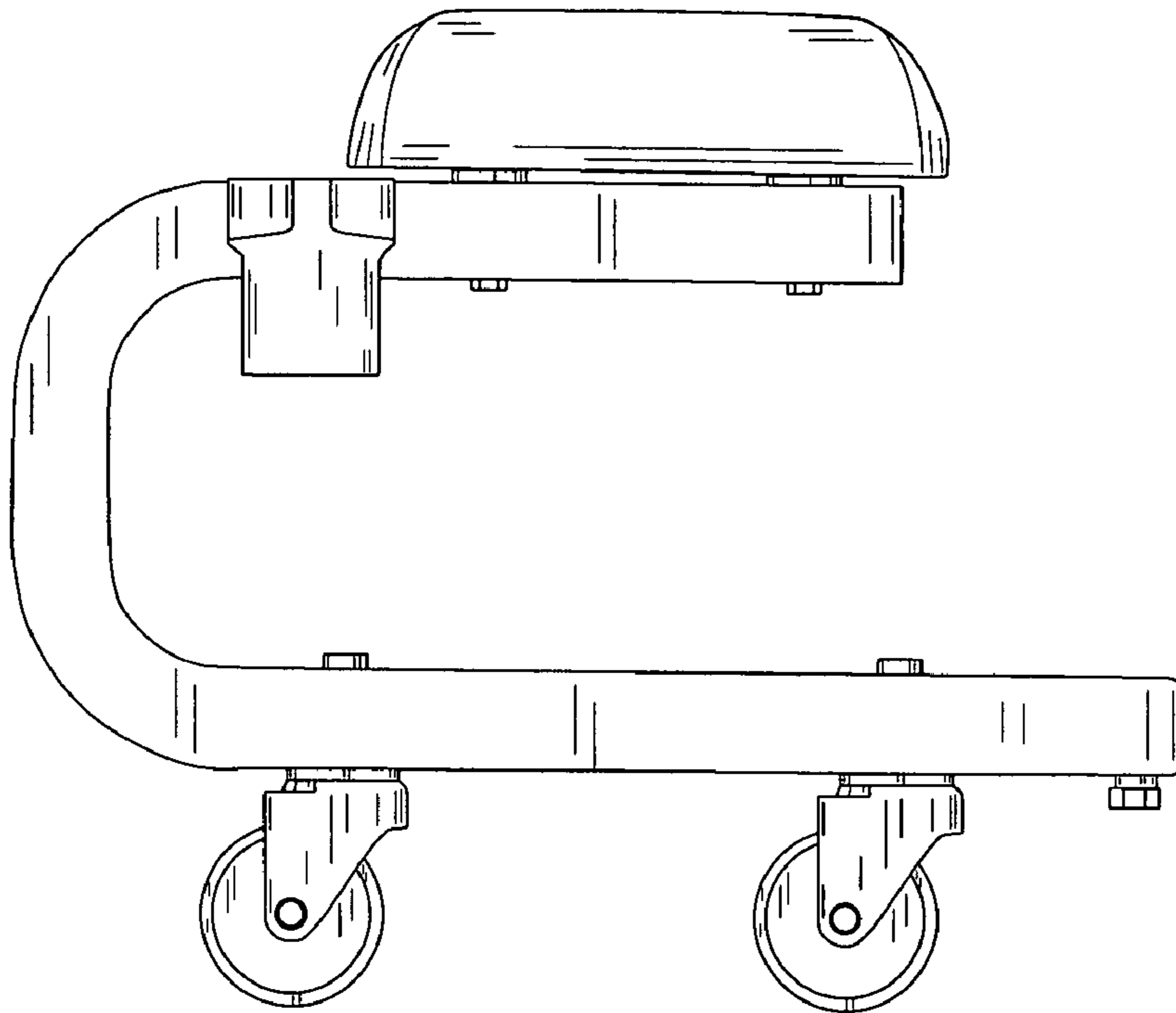

FIG. 6

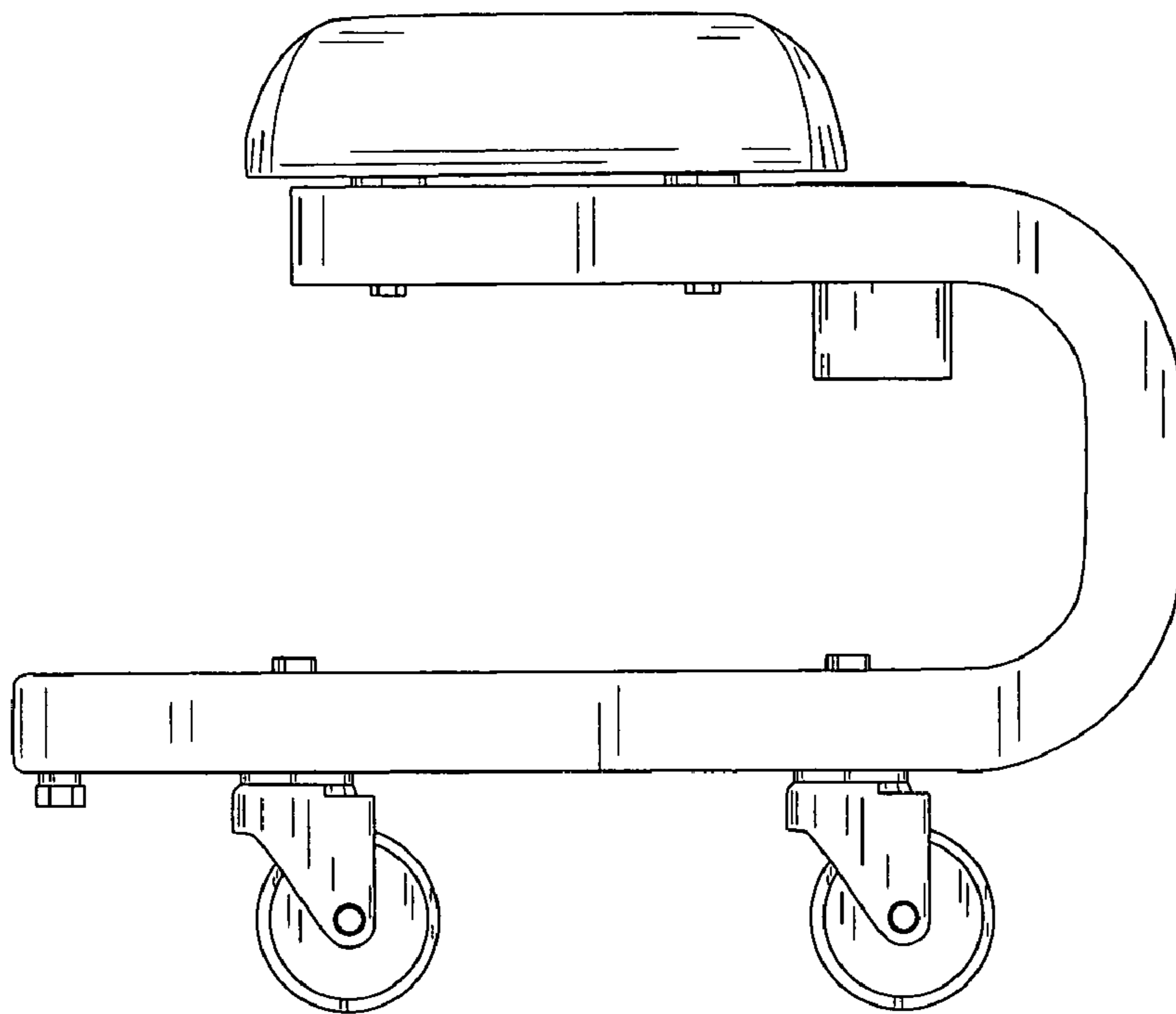

FIG. 7

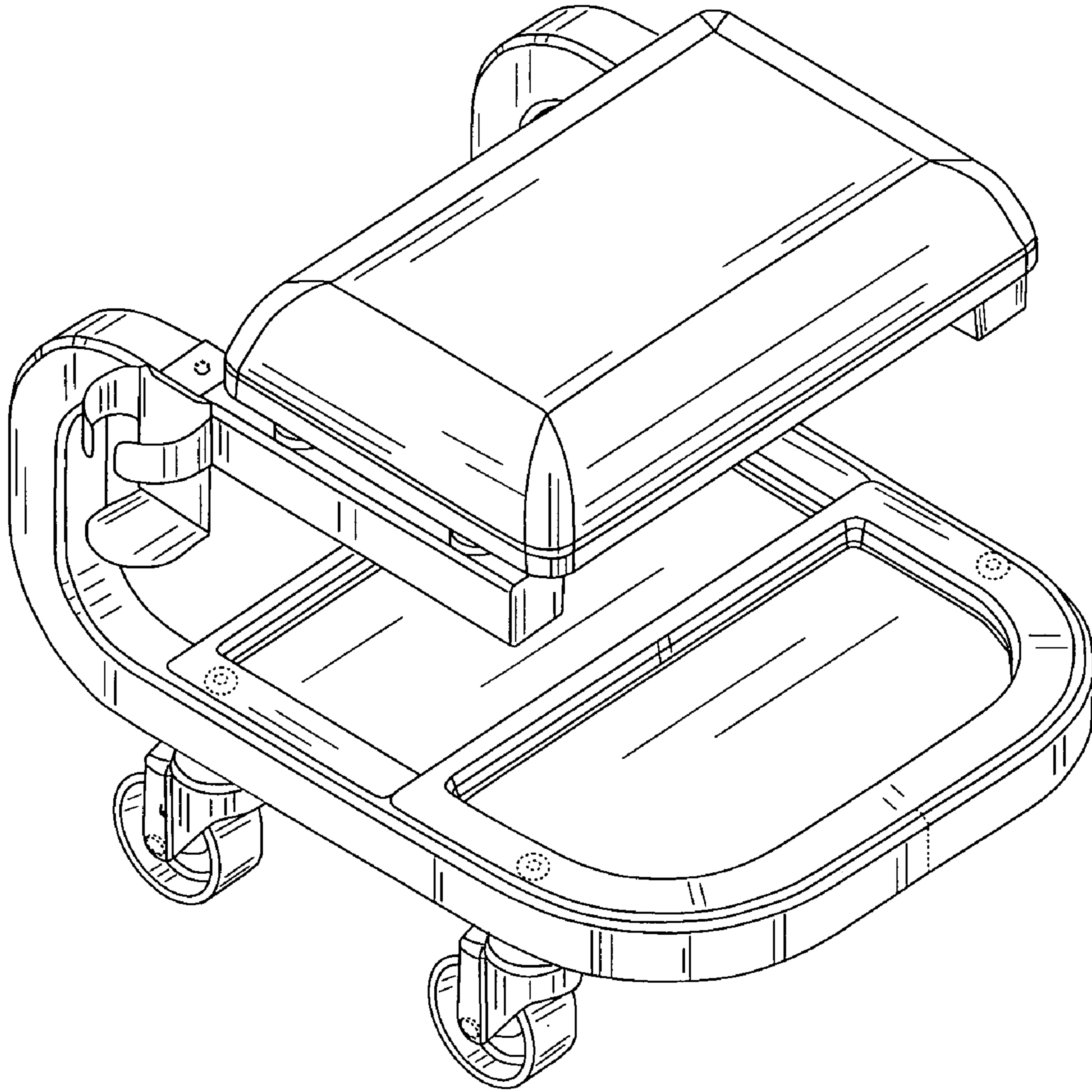

FIG. 8

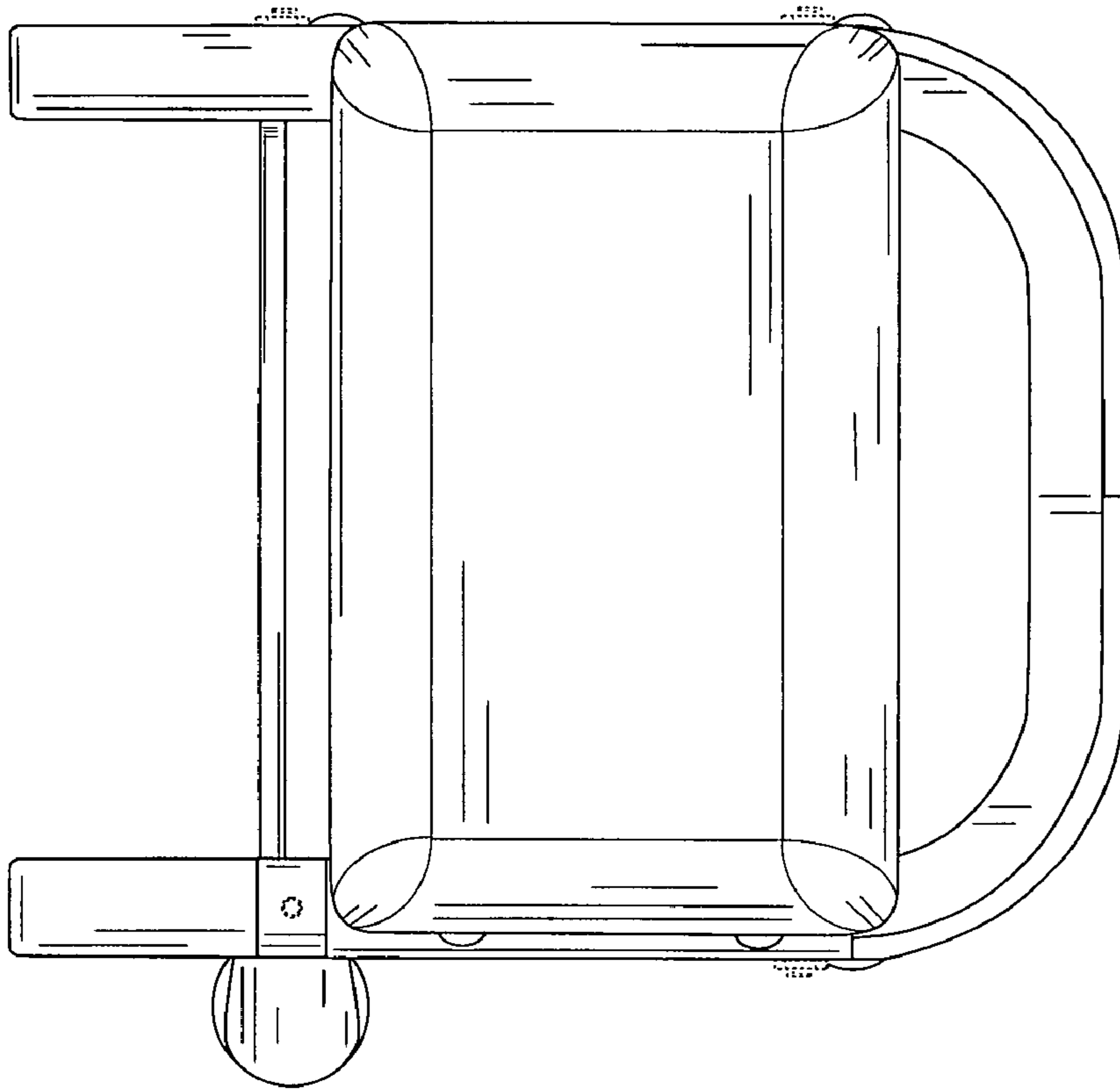

FIG. 9

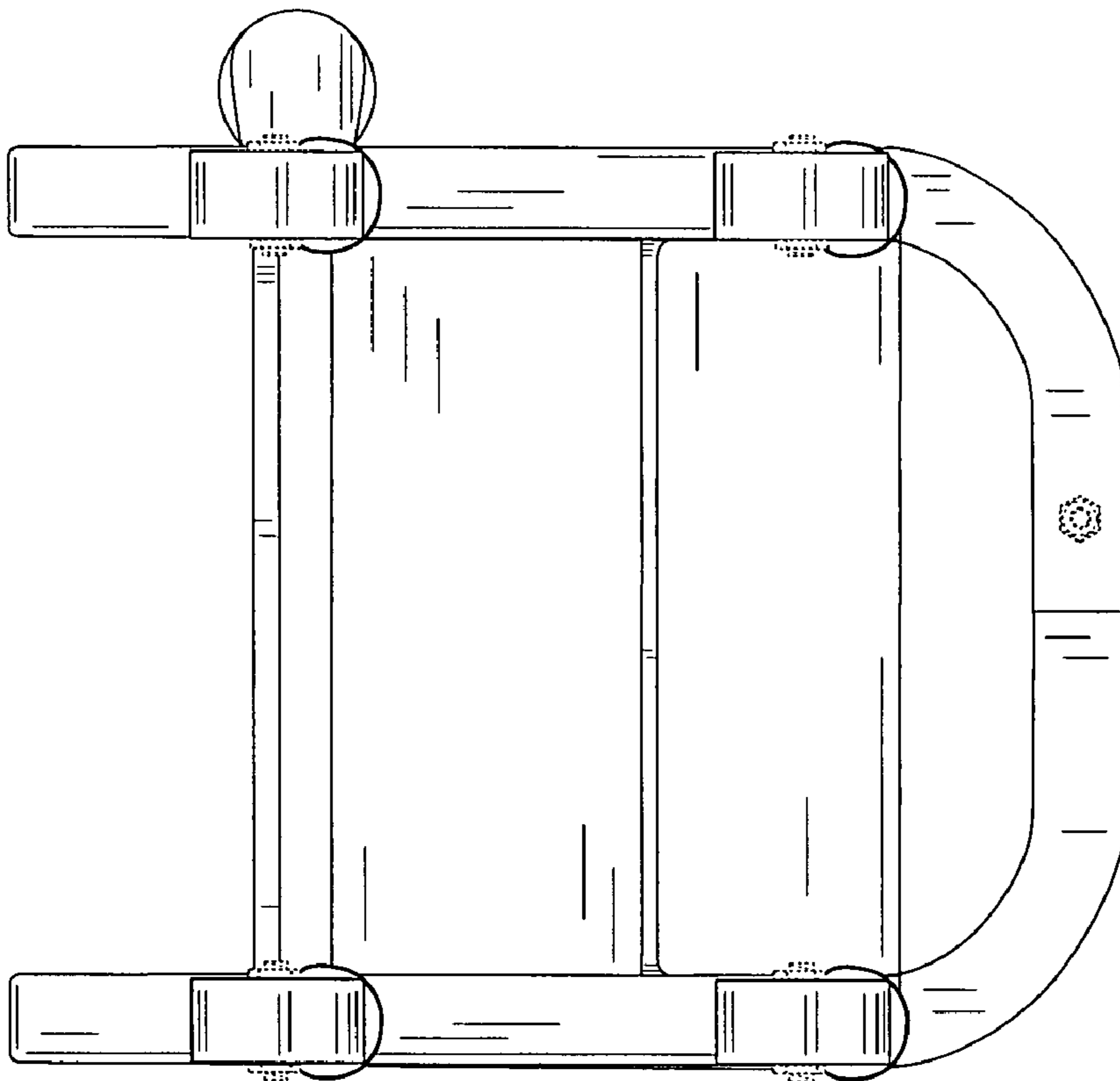

FIG. 10

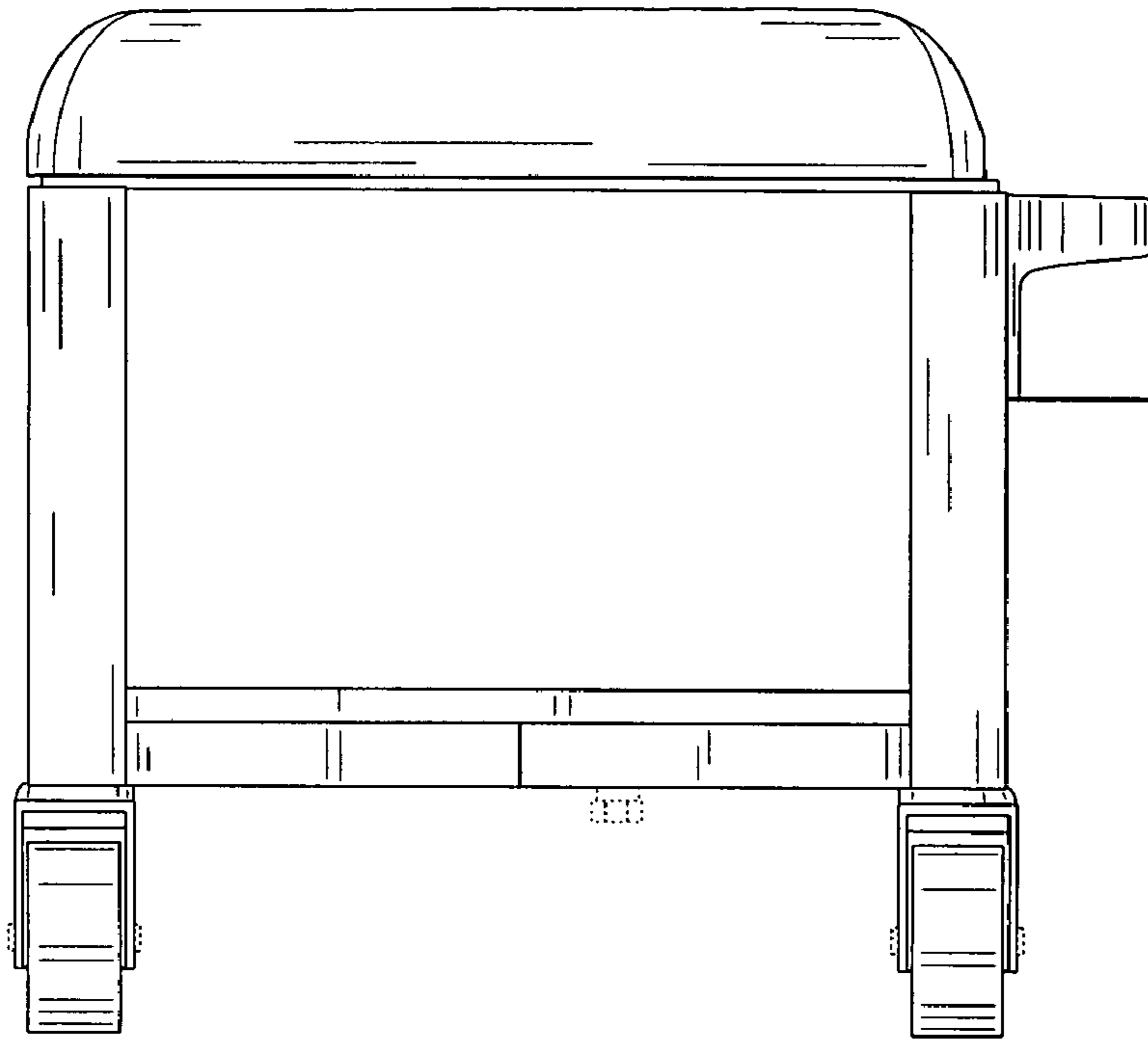

FIG. 11

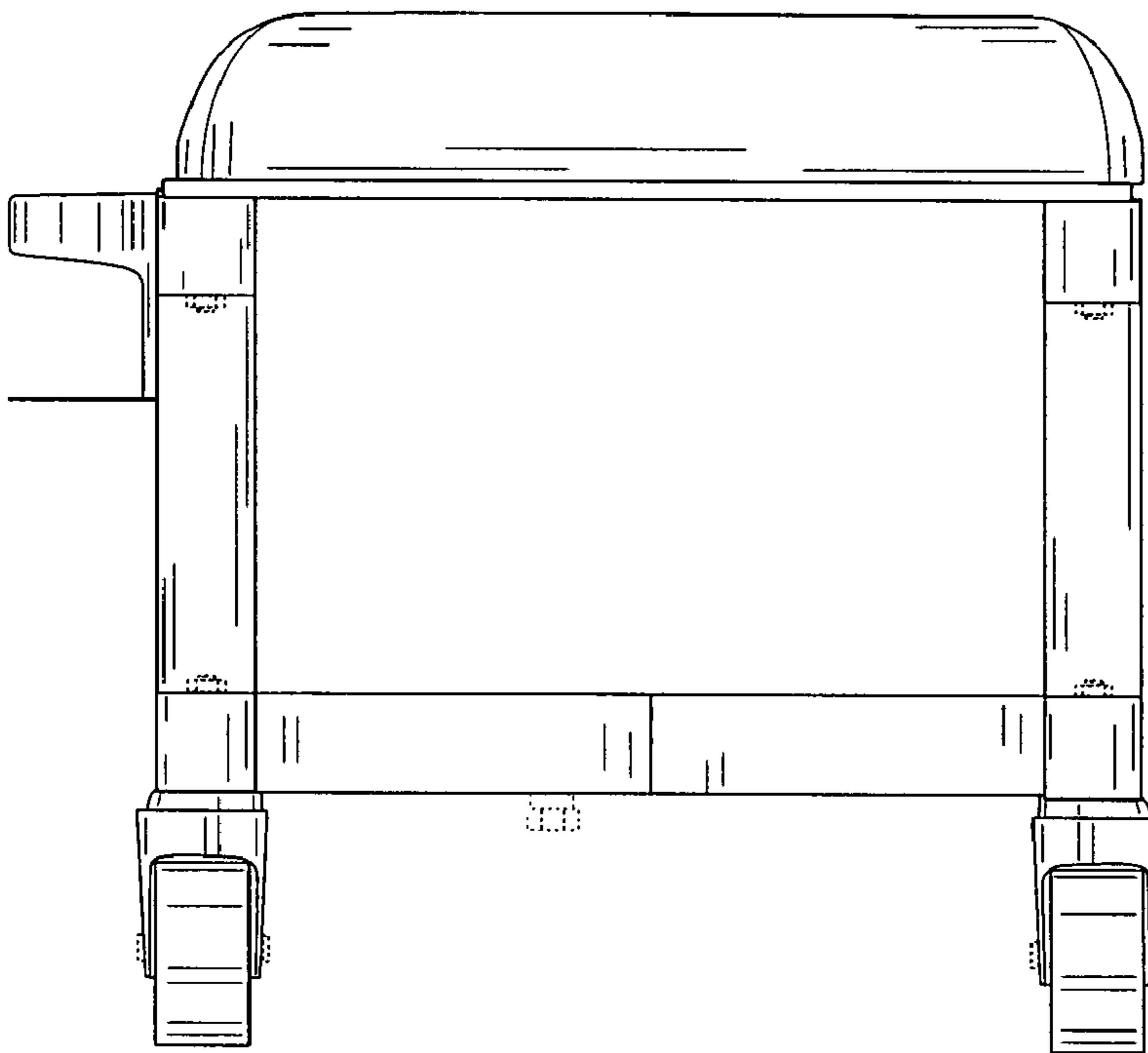

FIG. 12

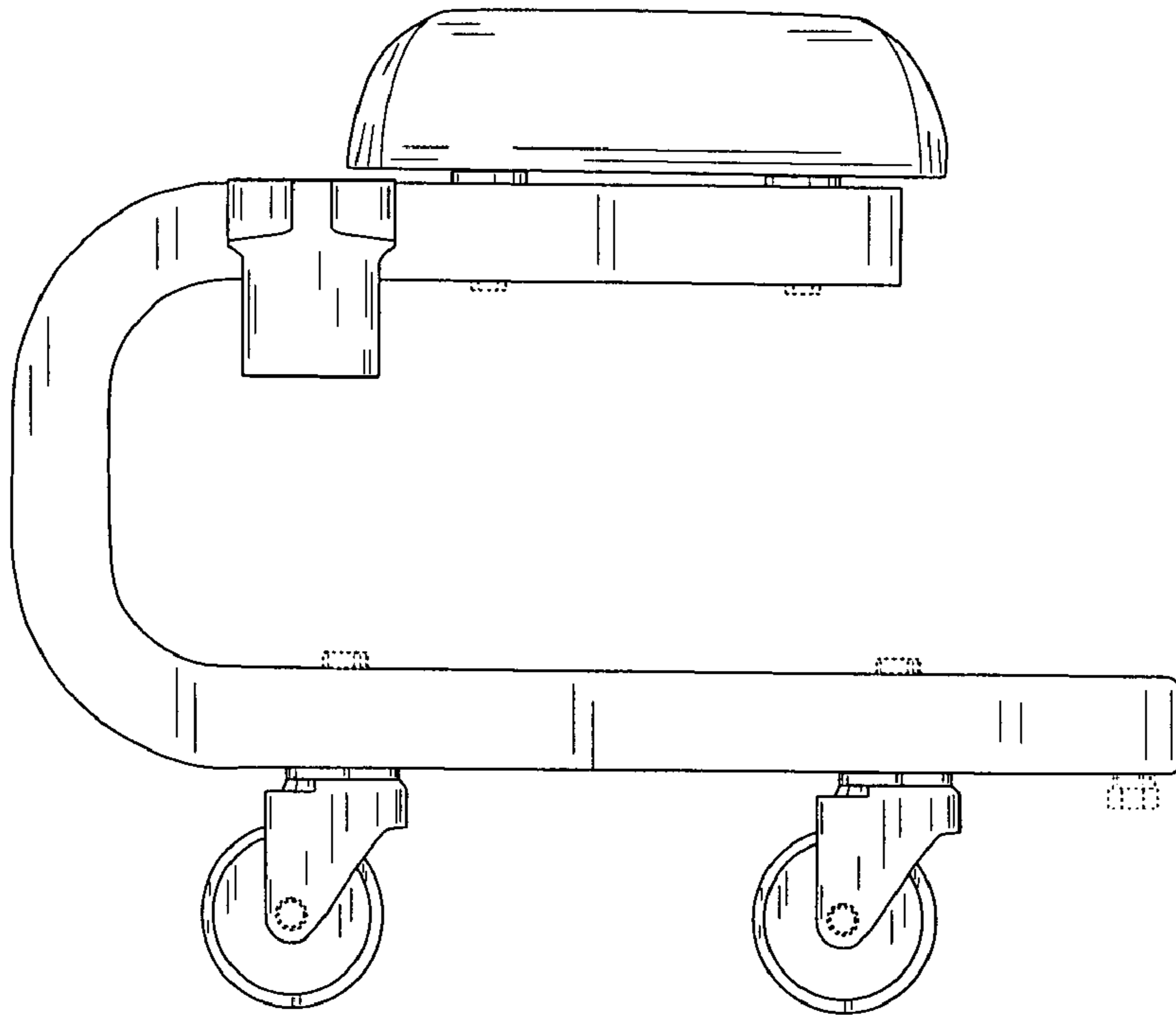

FIG. 13

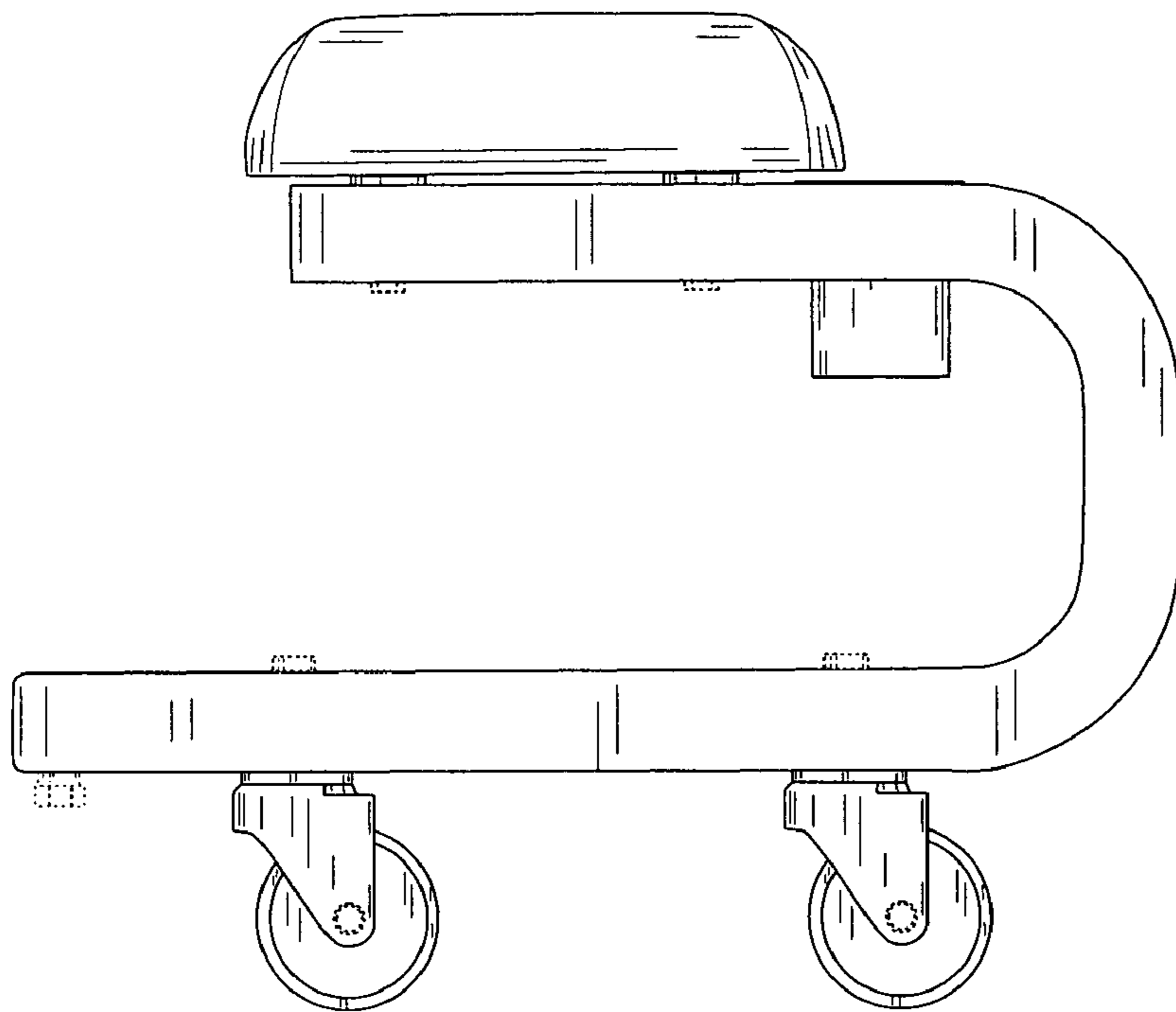

FIG. 14