



US00D579197S

(12) **United States Design Patent**
Forte

(10) **Patent No.:** **US D579,197 S**
(45) **Date of Patent:** **** Oct. 28, 2008**

(54) **HANDBAG**

(75) Inventor: **Christina Forte**, 545 Harbour View Dr., Kill Devil Hills, NC (US) 27948

(73) Assignee: **Christina Forte**, Kill Devil Hills, NC (US)

(**) Term: **14 Years**

(21) Appl. No.: **29/294,866**

(22) Filed: **Jan. 31, 2008**

(51) **LOC (8) Cl.** **03-01**

(52) **U.S. Cl.** **D3/238**

(58) **Field of Classification Search** D3/232-234, D3/238, 240-246; 150/100, 103-104, 107-110, 150/114, 118-119

See application file for complete search history.

(56) **References Cited**

U.S. PATENT DOCUMENTS

D123,840 S *	12/1940	Morris	D3/245
D174,859 S *	5/1955	Kaplan	D3/243
D232,130 S *	7/1974	Burkett	D3/238
D386,901 S *	12/1997	Goldban	D3/246

D403,151 S *	12/1998	Heredos-Formby	D3/246
D413,436 S *	9/1999	Melvin et al.	D3/234
D521,727 S *	5/2006	Albini	D3/238

* cited by examiner

Primary Examiner—Holly H Baynham

(57) **CLAIM**

The ornamental design for a handbag, as shown and described.

DESCRIPTION

FIG. 1 is a front perspective view of a handbag showing my handbag design;

FIG. 2 is the front view of the handbag;

FIG. 3 is a top view of the handbag;

FIG. 4 is the rear view of the handbag;

FIG. 5 is a bottom view of the handbag;

FIG. 6 is a right-side view of the handbag; and,

FIG. 7 is a left-side view of the handbag.

The dashed line on FIGS. 1, 2, 4 indicates stitching and is part of the design.

1 Claim, 4 Drawing Sheets

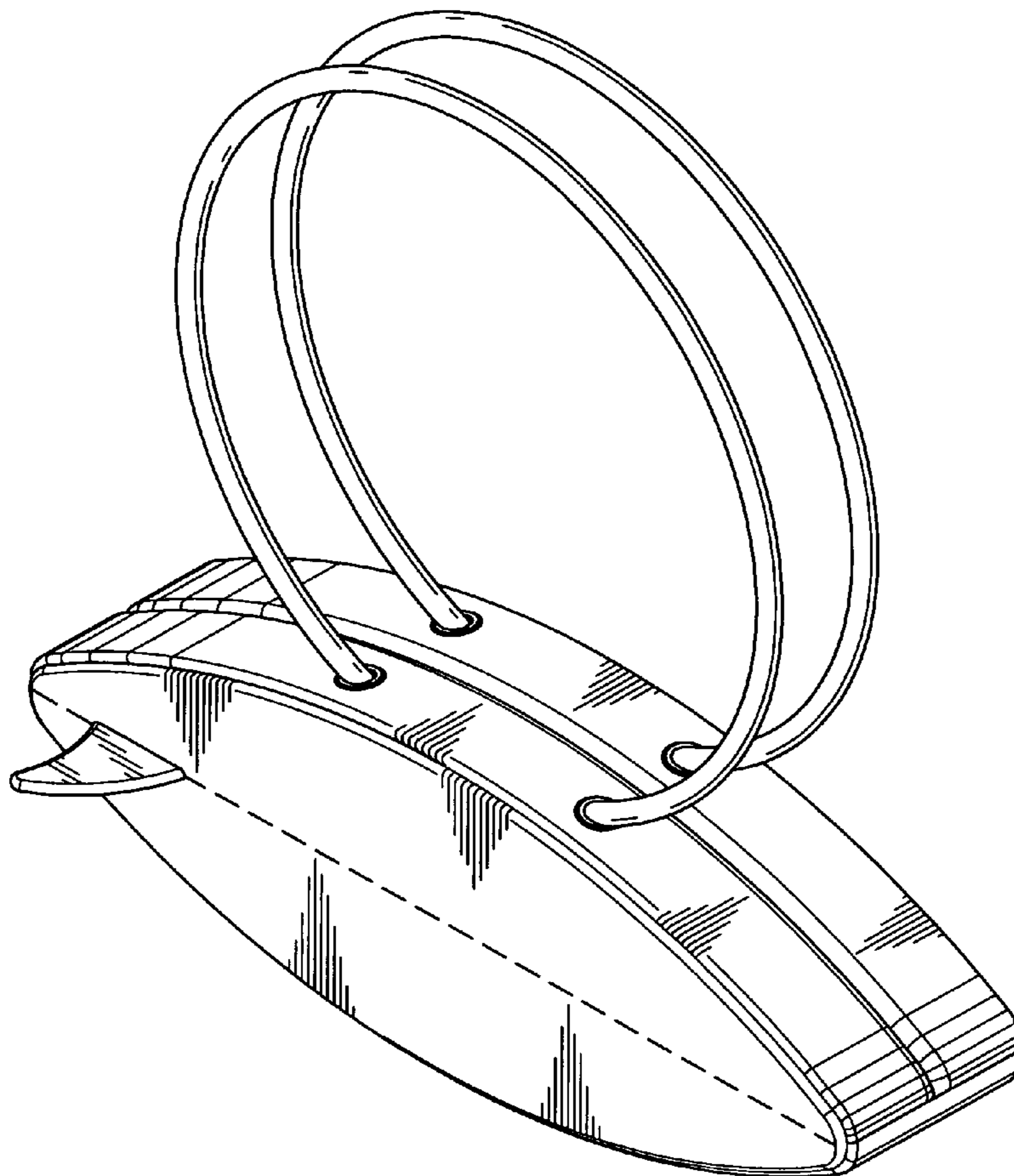

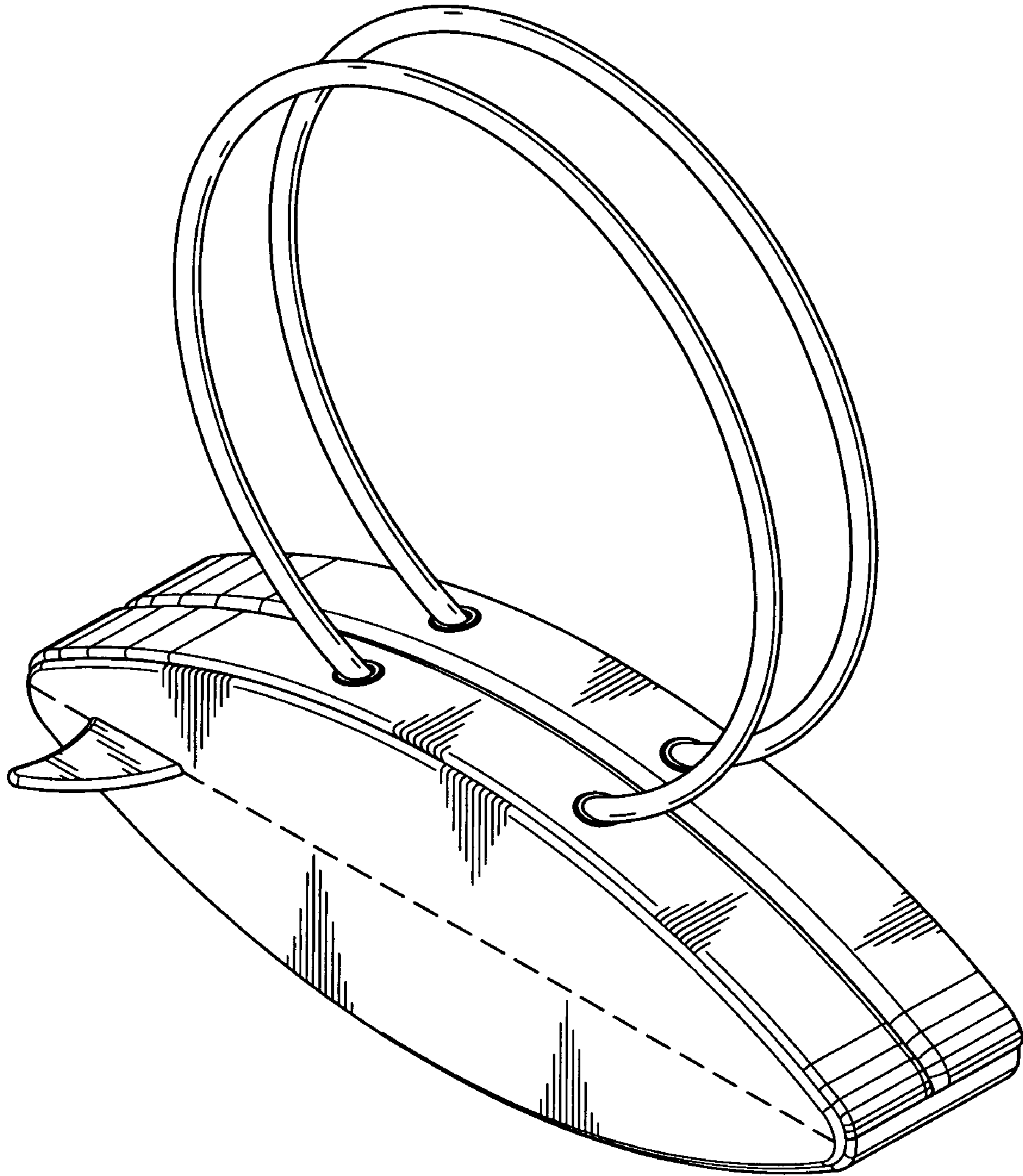

FIG.-1

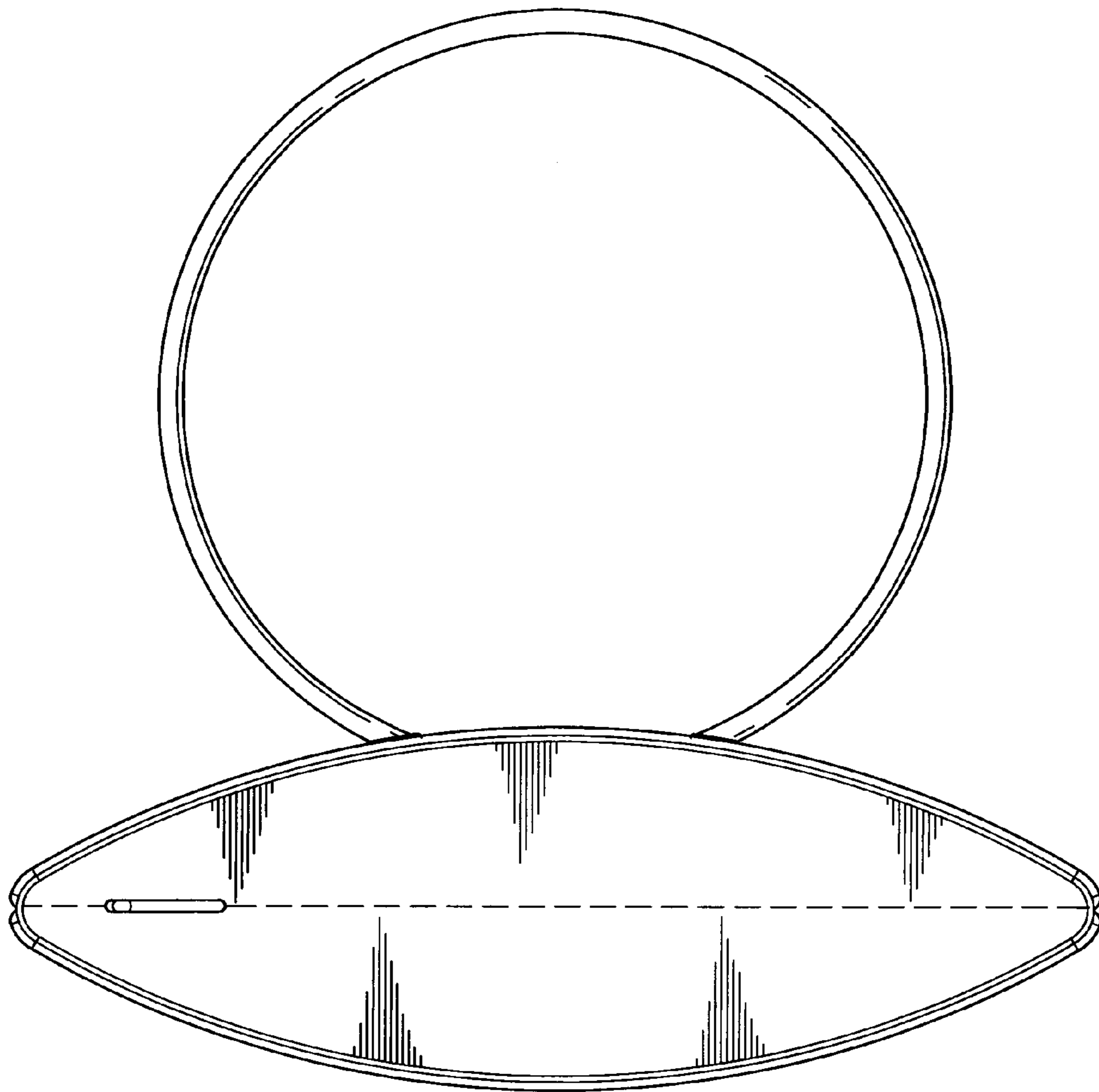

FIG.-2

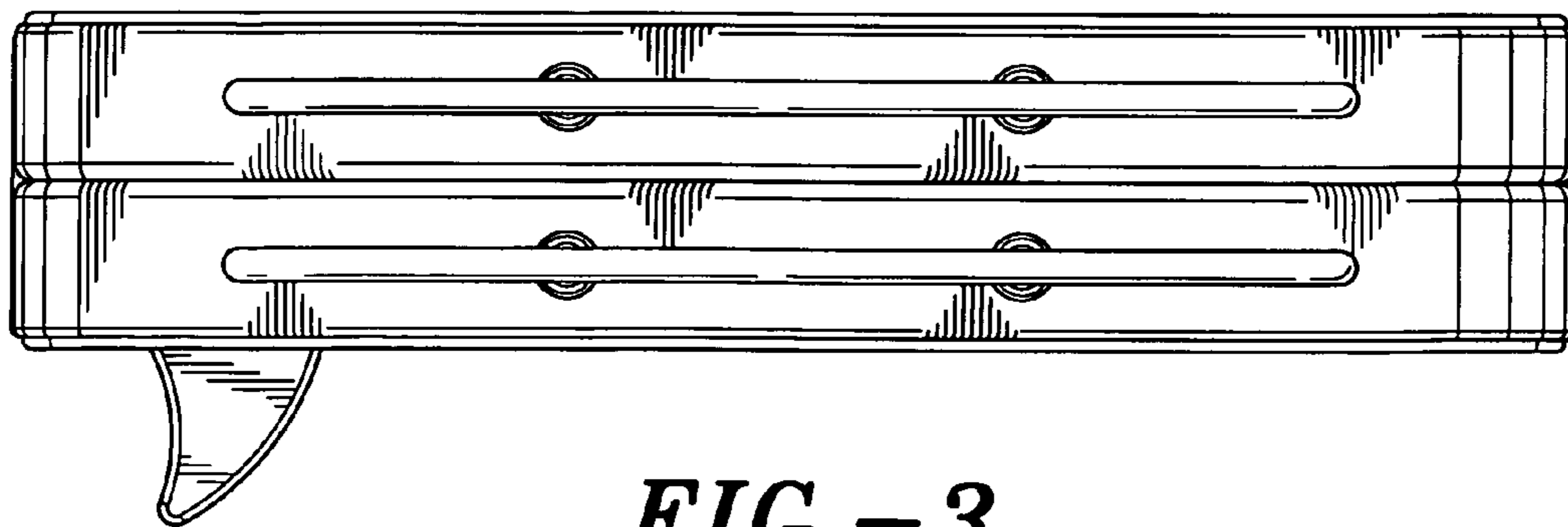

FIG.-3

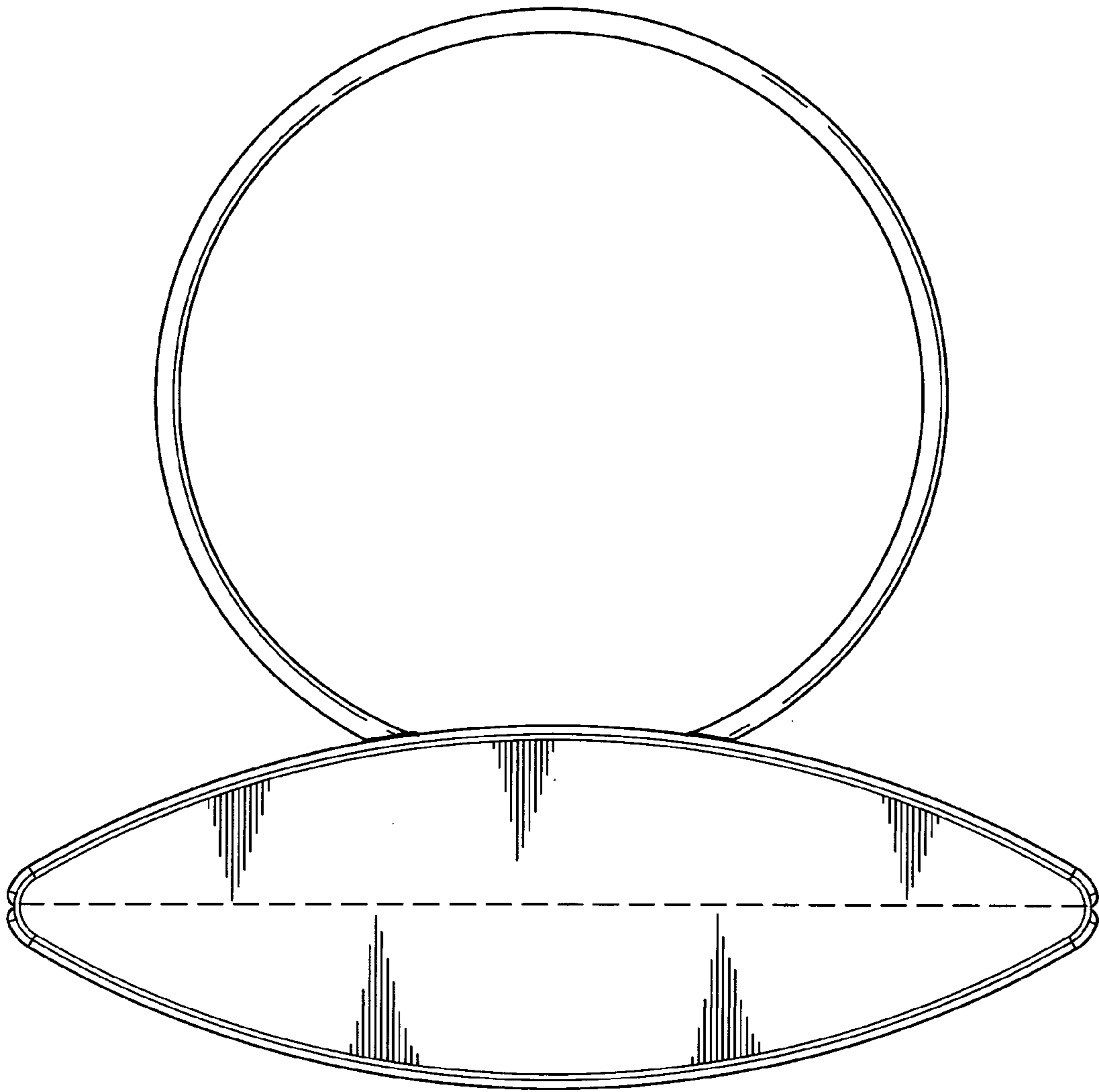

FIG.-4

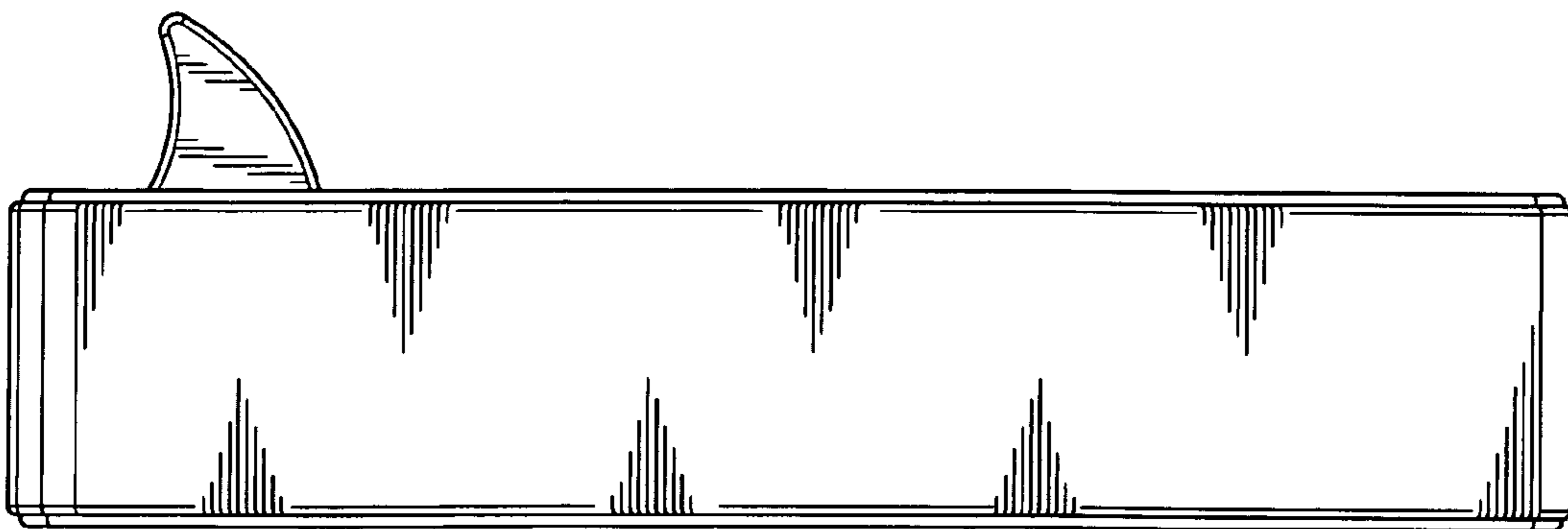

FIG.-5

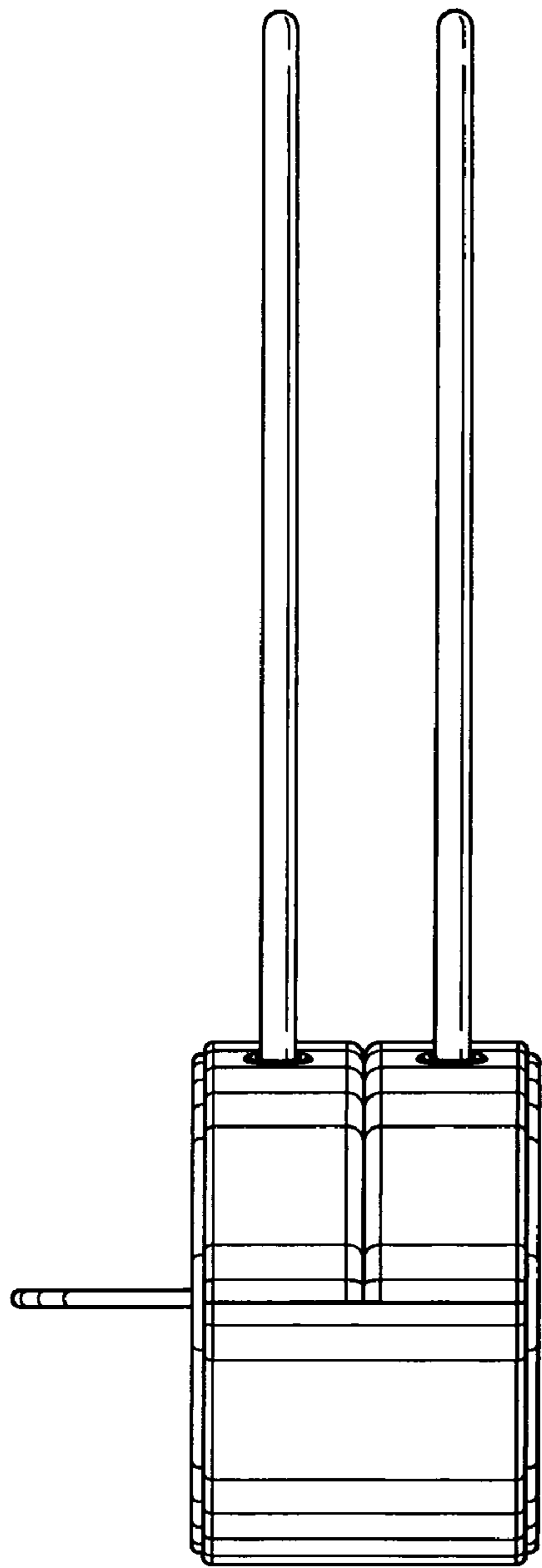

FIG.-6

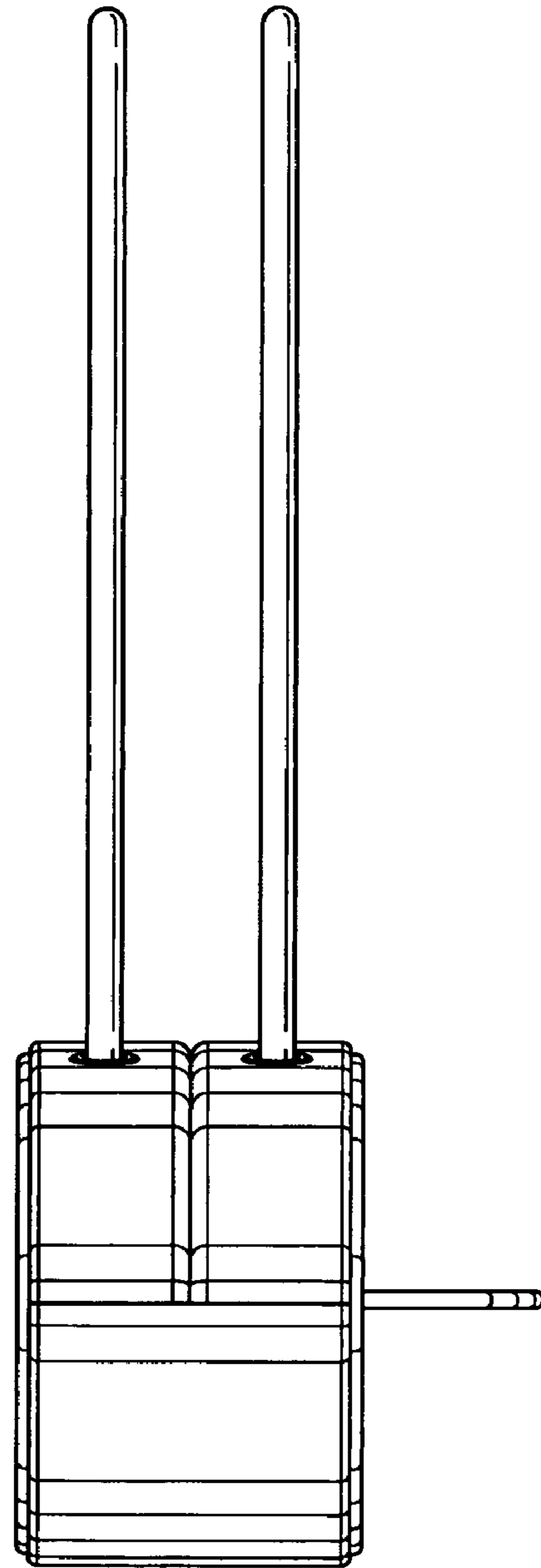

FIG.-7