



US00D578944S

(12) **United States Design Patent**  
**Dolan et al.**

(10) **Patent No.:** **US D578,944 S**  
(45) **Date of Patent:** **\*\* Oct. 21, 2008**

(54) **SIDE SKIRT FOR A TRUCK**

(75) Inventors: **Robert A. Dolan**, Gilbert, AZ (US);  
**David L. Simpson**, Higley, AZ (US)

(73) Assignee: **U-Haul International, Inc.**, Phoenix,  
AZ (US)

(\*\*) Term: **14 Years**

(21) Appl. No.: **29/253,436**

(22) Filed: **Feb. 7, 2006**

(51) **LOC (8) Cl.** ..... **12-16**

(52) **U.S. Cl.** ..... **D12/196**

(58) **Field of Classification Search** ..... D12/196,  
D12/190, 97, 181, 96; 296/56, 57.1, 183.1,  
296/180.1-180.3; 280/727, 762, 768, 770

See application file for complete search history.

(56) **References Cited**

U.S. PATENT DOCUMENTS

3,775,917 A 12/1973 Struben  
(Continued)

FOREIGN PATENT DOCUMENTS

JP 2002019574 1/2002

*Primary Examiner*—Melody N Brown

(74) *Attorney, Agent, or Firm*—Richard E. Oney; Tiffany &  
Bosco, PA

(57) **CLAIM**

We claim the ornamental design for a side skirt for a truck, as  
shown and described.

**DESCRIPTION**

The truck skirt according to the inventive design is for use on  
the side of a truck or moving van. As shown in each of the  
three embodiments depicted, the design can include a forward  
panel portion for mounting forward the rear wheel of the truck  
or van and a rear panel portion for mounting rearward of the  
rear wheel.

FIG. 1 is a perspective view of a side skirt for a truck showing  
our new design, it being understood that the broken lines are  
for illustrative purposes only and form no part of the claimed  
design;

FIG. 2 is a front elevation view of the forward panel portion of  
the truck skirt of FIG. 1;

FIG. 3 is a top plan view of the forward panel portion of the  
truck skirt of FIG. 1;

FIG. 4 is a bottom plan view of the forward panel portion of  
the truck skirt of FIG. 1;

FIG. 5 is a left side elevation view of the forward panel  
portion of the truck skirt of FIG. 1;

FIG. 6 is a right side elevation view of the forward panel  
portion of the truck skirt of FIG. 1;

FIG. 7 is a front elevation view of the rear panel portion of the  
truck skirt of FIG. 1;

FIG. 8 is a top plan view of the rear panel portion of the truck  
skirt of FIG. 1;

FIG. 9 is a bottom plan view of the rear panel portion of the  
truck skirt of FIG. 1;

FIG. 10 is a left side elevation view of the rear panel portion  
of the truck skirt of FIG. 1;

FIG. 11 is a right side elevation view of the rear panel portion  
of the truck skirt of FIG. 1;

FIG. 12 is a perspective view of a side skirt for a truck  
showing a second embodiment of the new design, it being  
understood that the broken lines are for illustrative purposes  
only and form no part of the claimed design;

FIG. 13 is a front elevation view of the forward panel portion  
of the truck skirt of FIG. 12;

FIG. 14 is a top plan view of the forward panel portion of the  
truck skirt of FIG. 12;

FIG. 15 is a bottom plan view of the forward panel portion of  
the truck skirt of FIG. 12;

FIG. 16 is a left side elevation view of the forward panel  
portion of the truck skirt of FIG. 12; and,

FIG. 17 is a right side elevation view of the forward panel  
portion of the truck skirt of FIG. 12.

The elevation, plan and side views of the rear panel portion of  
the truck skirt of FIG. 12 are the same as those of the embodi-  
ment of FIG. 1, as shown in FIGS. 7-11.

**1 Claim, 5 Drawing Sheets**

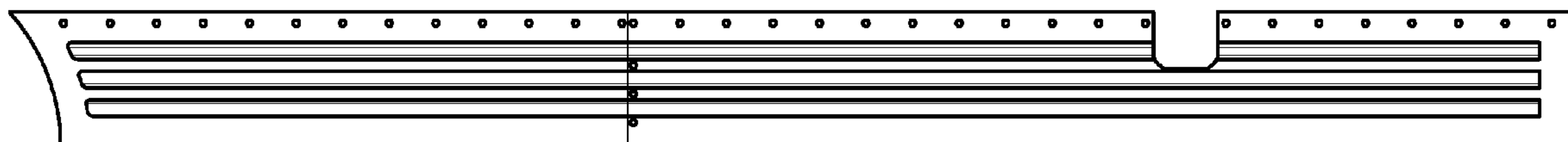

# US D578,944 S

Page 2

---

## U.S. PATENT DOCUMENTS

4,529,244	A	7/1985	Zaydel				
4,573,733	A	3/1986	Zaydel				
D313,954	S	1/1991	Fingerle				
D319,036	S	8/1991	Fingerle				
D354,726	S	* 1/1995	Fitzgerald et al.	.....	D12/181		
D388,024	S	* 12/1997	Clement	.....	D12/97		
D420,622	S	* 2/2000	Hellhake et al.	.....	D12/97		
D433,365	S	11/2000	Beigel				
D478,854	S	* 8/2003	Platto et al.	.....	D12/196		
6,722,730	B2	4/2004	Lydan et al.				
D493,758	S	* 8/2004	Platto et al.	.....	D12/196		
D495,645	S	* 9/2004	Hall et al.	.....	D12/196		
D499,679	S	* 12/2004	Perfetti et al.	.....	D12/196		

\* cited by examiner

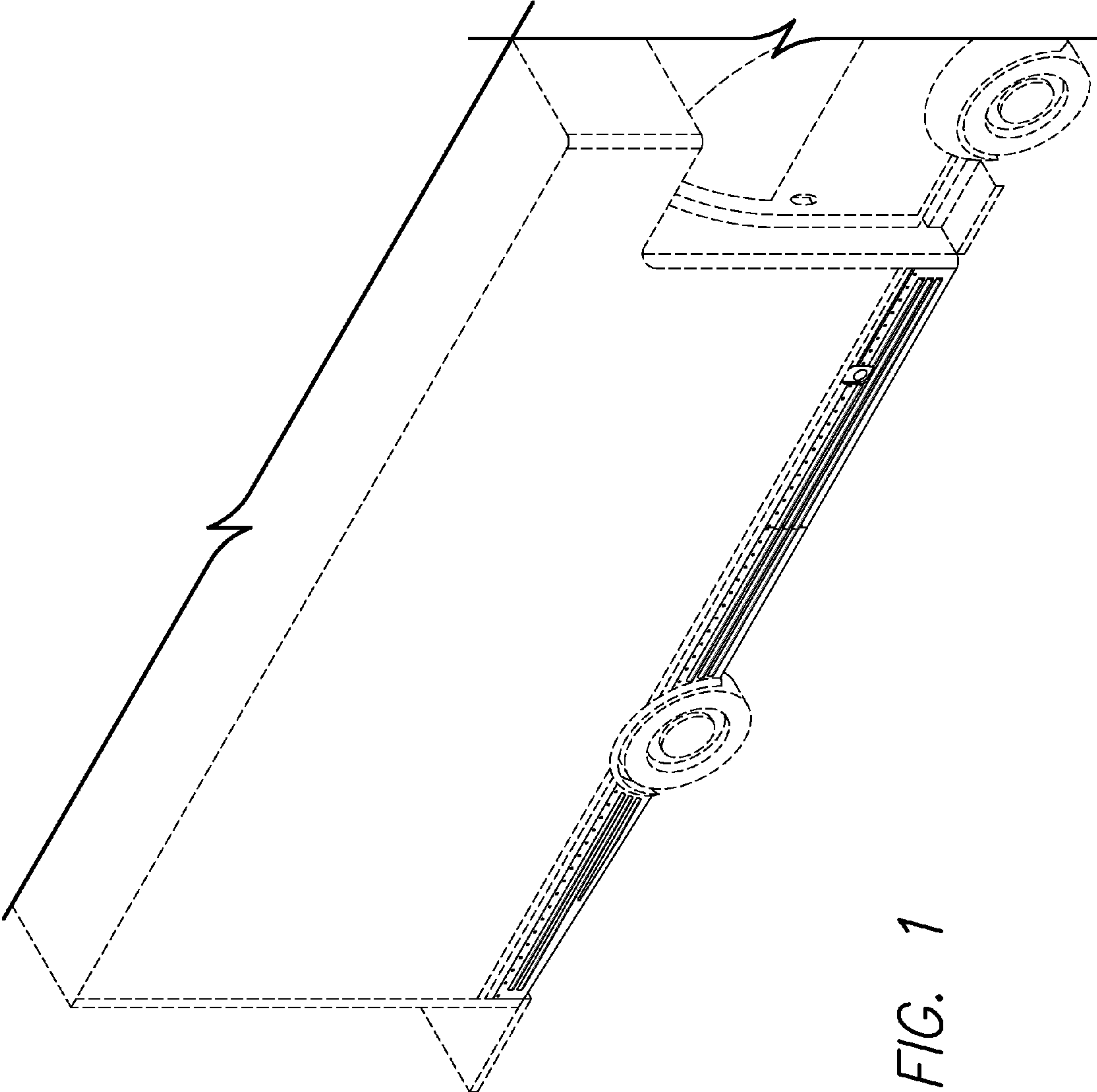

FIG. 1



FIG. 3

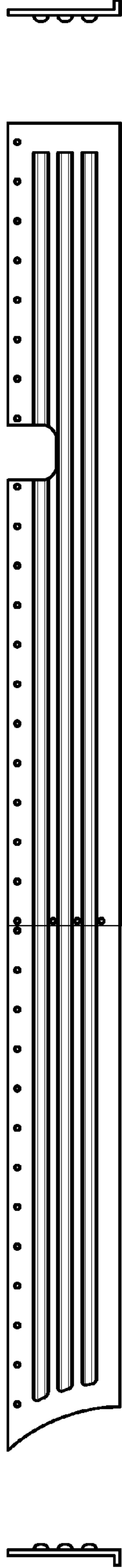

FIG. 5

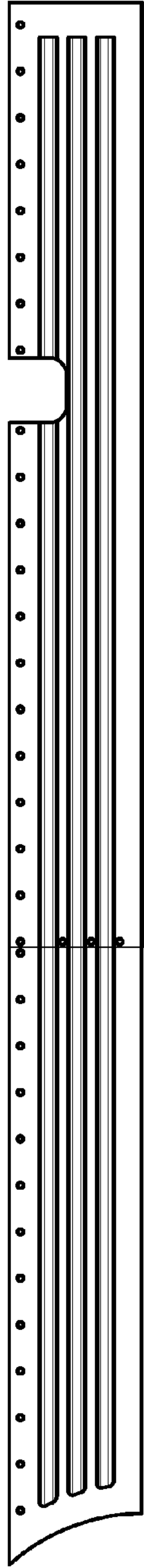

FIG. 2

FIG. 6



FIG. 4



FIG. 8



FIG. 10

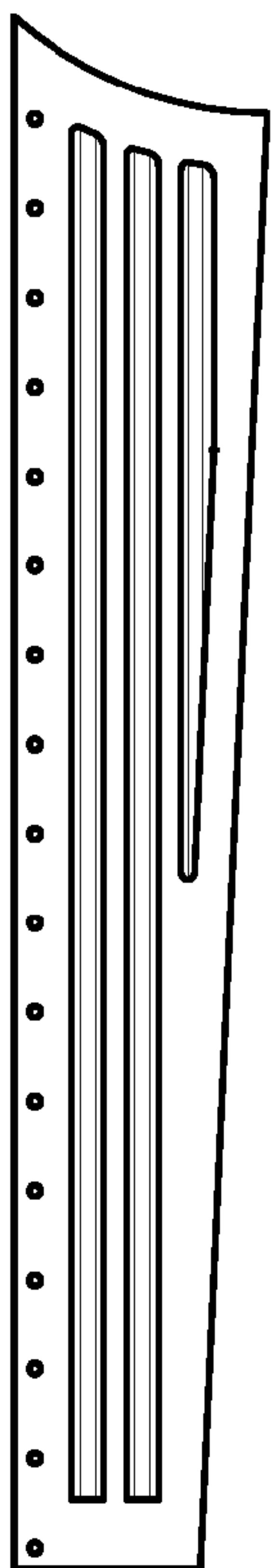

FIG. 7



FIG. 11



FIG. 9

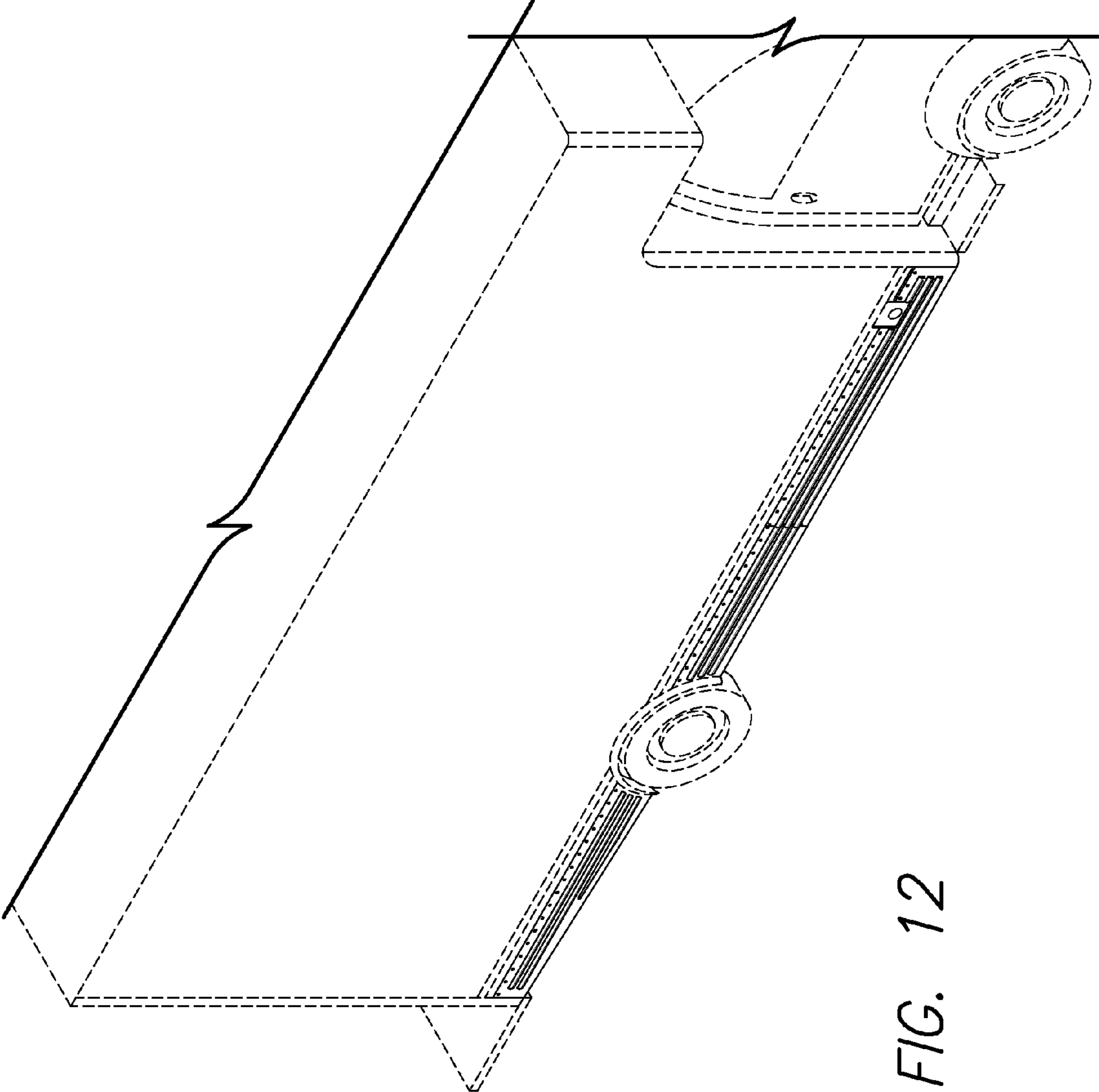

FIG. 12



FIG. 14

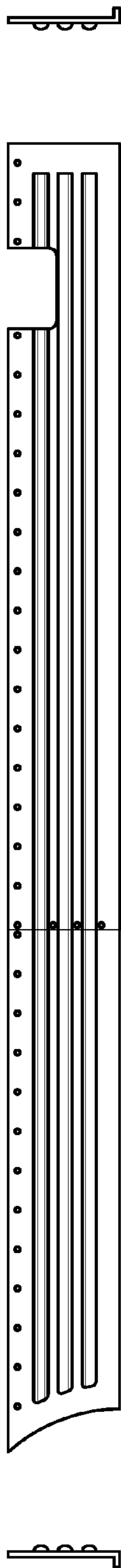

FIG. 13

FIG. 16

FIG. 17

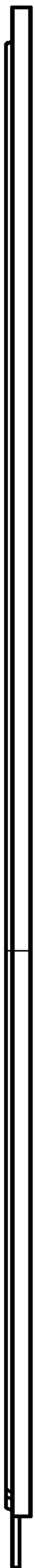

FIG. 15