



US00D578705S

(12) **United States Design Patent**  
**Aberg et al.**

(10) **Patent No.:** **US D578,705 S**  
(45) **Date of Patent:** **\*\* Oct. 14, 2008**

(54) **EXTRUSION FOR BASE OF LINEAR LIGHTING APPARATUS**

(75) Inventors: **Cary R. Aberg**, Renton, WA (US); **Jens S. Cutter**, Rancho Santa Margarita, CA (US); **Judy K. Kastner**, Renton, WA (US)

(73) Assignee: **Led Power, Inc.**, Irvine, CA (US)

(\*\*) Term: **14 Years**

(21) Appl. No.: **29/280,603**

(22) Filed: **Jun. 1, 2007**

(51) **LOC (8) Cl.** ..... **26-99**

(52) **U.S. Cl.** ..... **D26/138**

(58) **Field of Classification Search** ..... D26/81,  
D26/155, 145, 86, 87, 113, 118, 128, 138,  
D26/85, 92, 97, 94, 65, 63, 62, 107, 142,  
D26/140, 120, 2, 25, 26, 37, 46, 72, 75, 76,  
D26/79, 103, 119, 124; 362/311, 309, 308,  
362/242, 147, 360, 151, 644, 654, 260, 363,  
362/382, 395, 410, 432

See application file for complete search history.

(56) **References Cited**

**U.S. PATENT DOCUMENTS**

4,246,629 A \* 1/1981 Marrero ..... 362/147  
4,338,653 A \* 7/1982 Marrero ..... 362/223  
4,613,930 A \* 9/1986 Ambasz ..... 362/223

4,625,267 A \* 11/1986 Mikalonis ..... 362/150  
D295,329 S \* 4/1988 Roos et al. .... D26/75  
4,933,820 A \* 6/1990 Engel ..... 362/217  
D316,613 S \* 4/1991 Stein ..... D26/122  
D321,407 S \* 11/1991 Heidmann ..... D26/72  
D356,876 S \* 3/1995 Waldmann ..... D26/107  
D379,530 S \* 5/1997 Leonelli ..... D25/124  
D384,178 S \* 9/1997 Costa ..... D26/76  
D445,211 S \* 7/2001 Baker ..... D26/76  
D459,014 S \* 6/2002 Chen ..... D26/85

\* cited by examiner

*Primary Examiner*—Freda S. Nunn

*Assistant Examiner*—Kevin K Rudzinski

(74) *Attorney, Agent, or Firm*—Jerry Turner Sewell

(57) **CLAIM**

The ornamental design for an extrusion for base of linear lighting apparatus, as shown and described.

**DESCRIPTION**

FIG. 1 is a perspective view of the extrusion for base of linear lighting apparatus of the present design.

FIG. 2 is a left side elevational view, the right side elevational view being a mirror image thereof.

FIG. 3 is a top plan view.

FIG. 4 is a front elevational view, the rear elevational view being a mirror image thereof; and,

FIG. 5 is a bottom plan view.

**1 Claim, 2 Drawing Sheets**

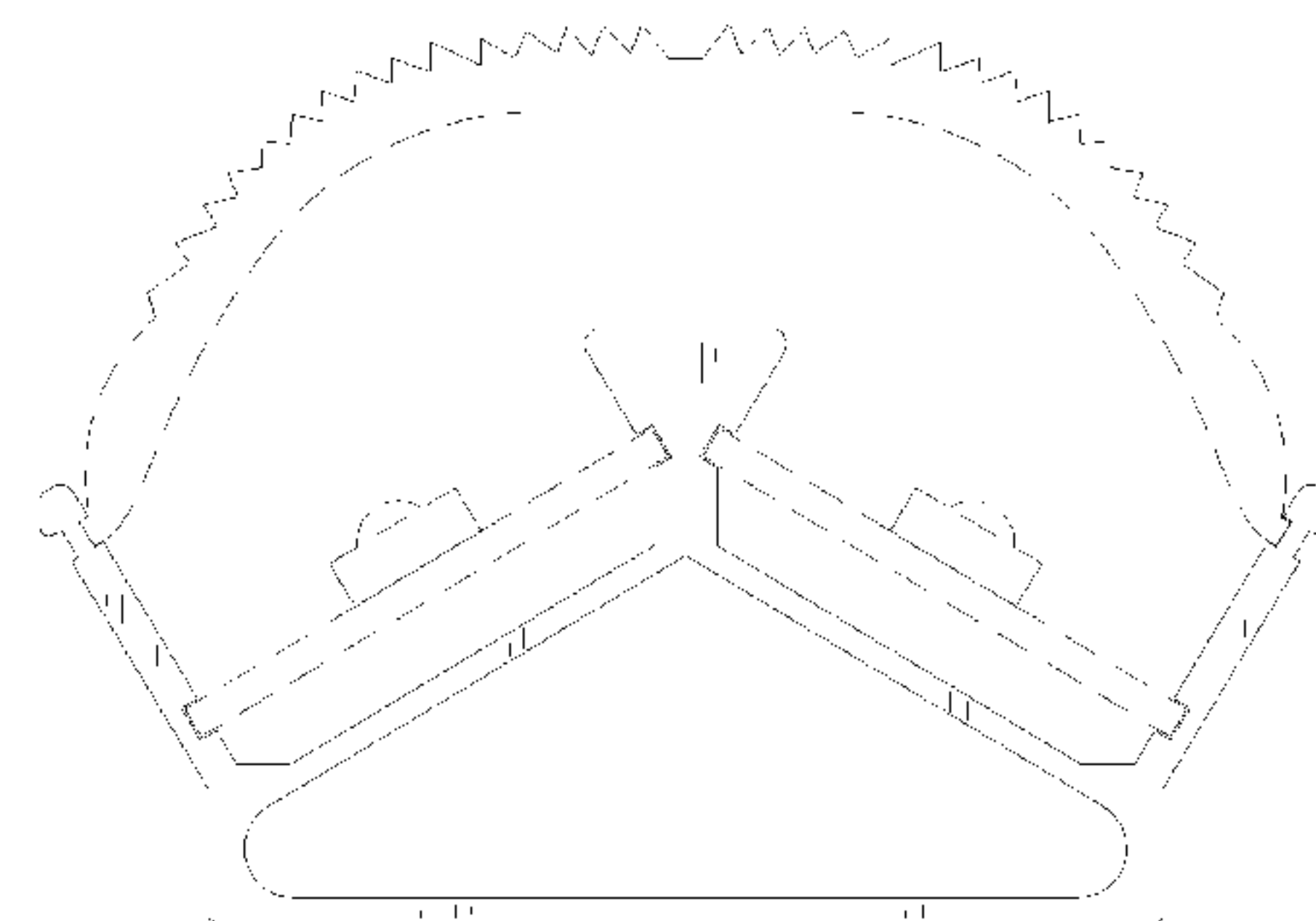
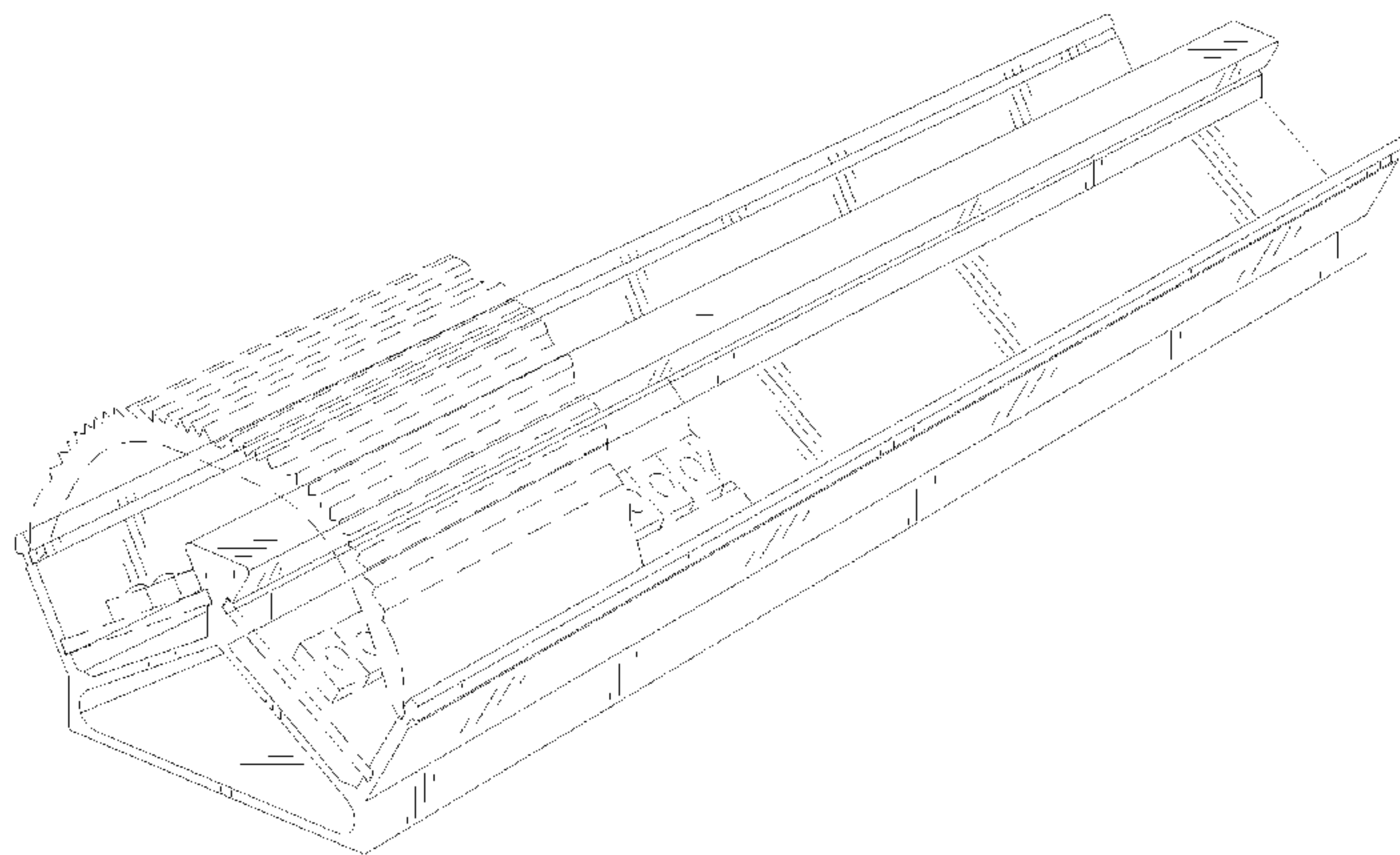

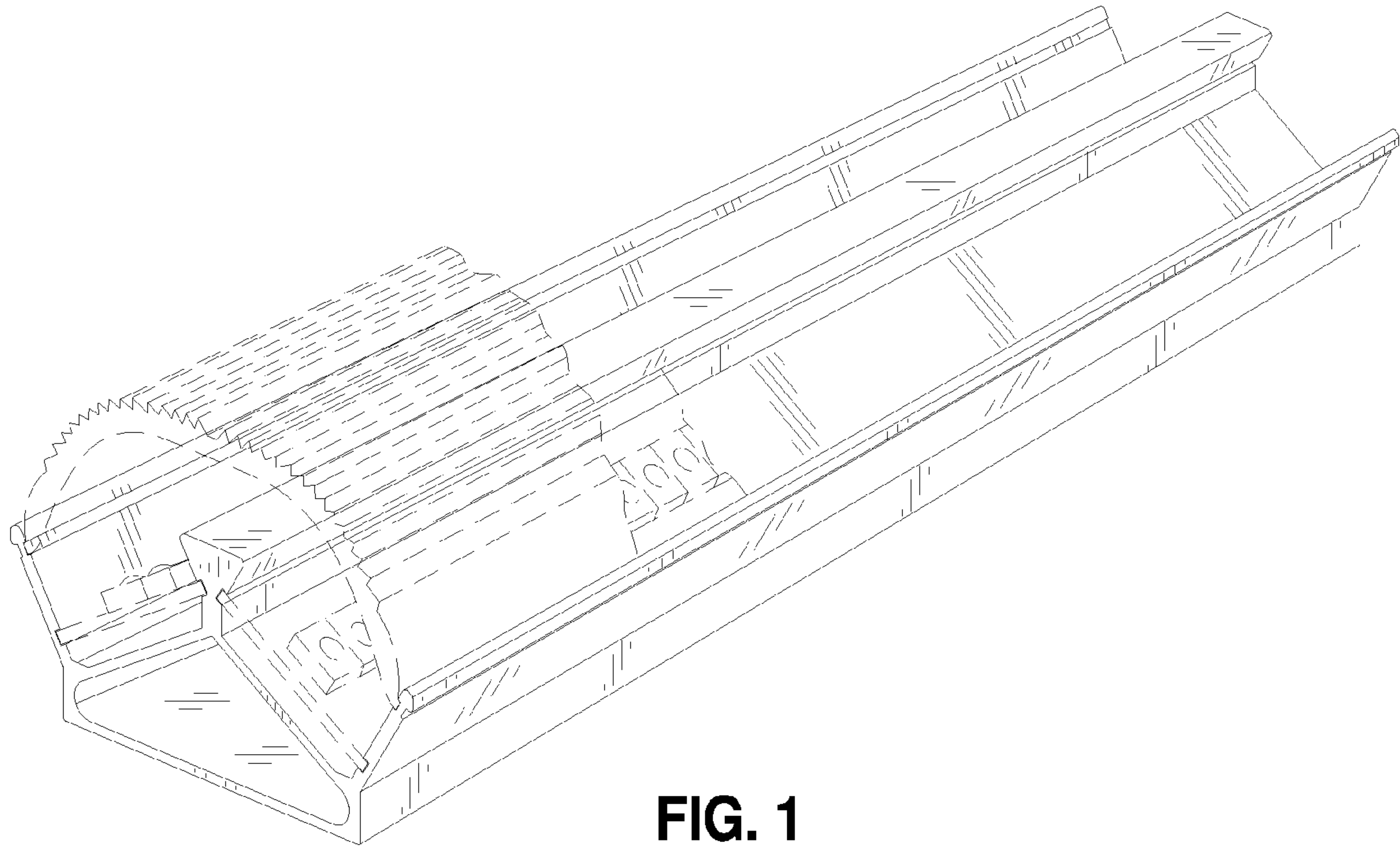

FIG. 1

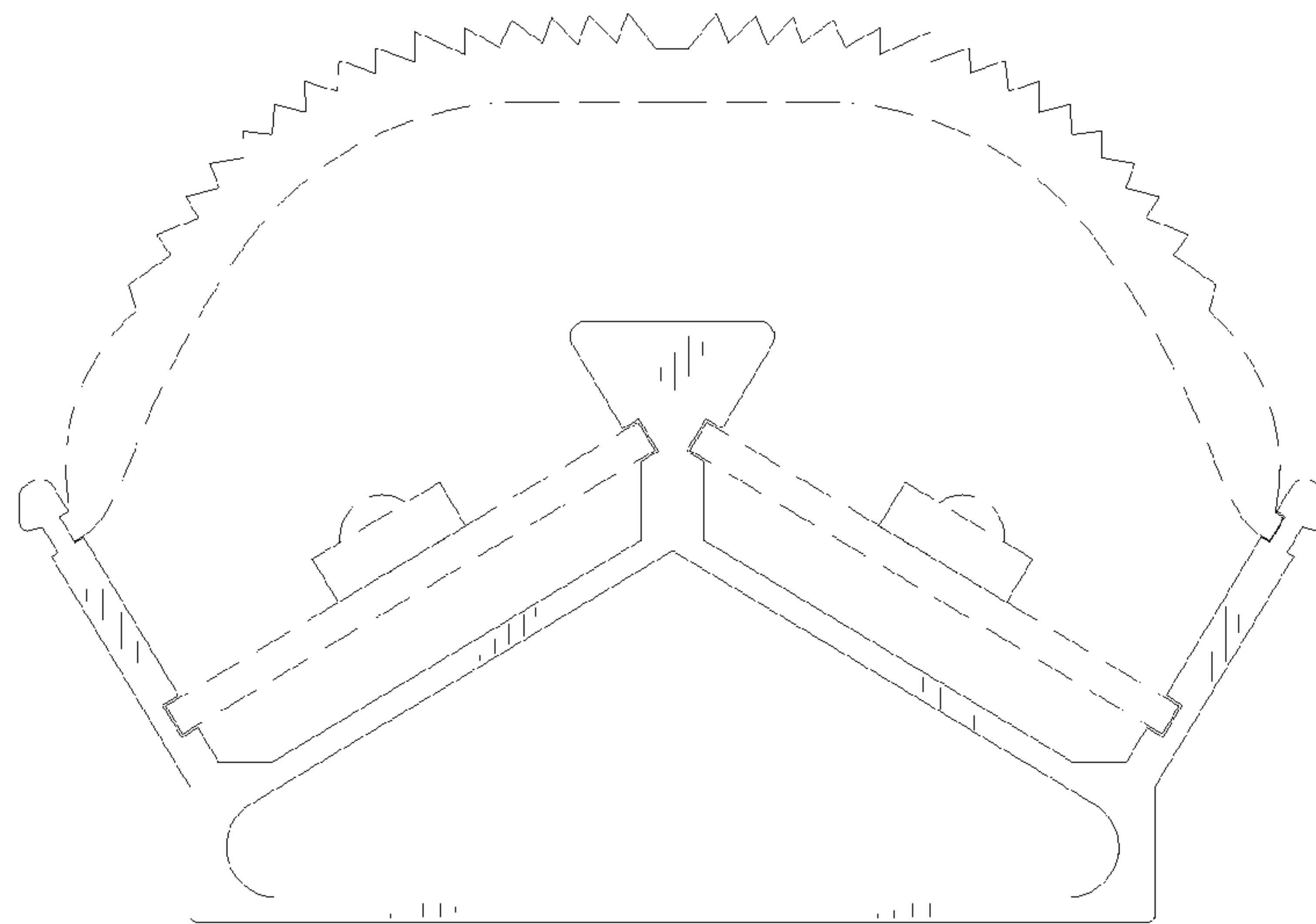
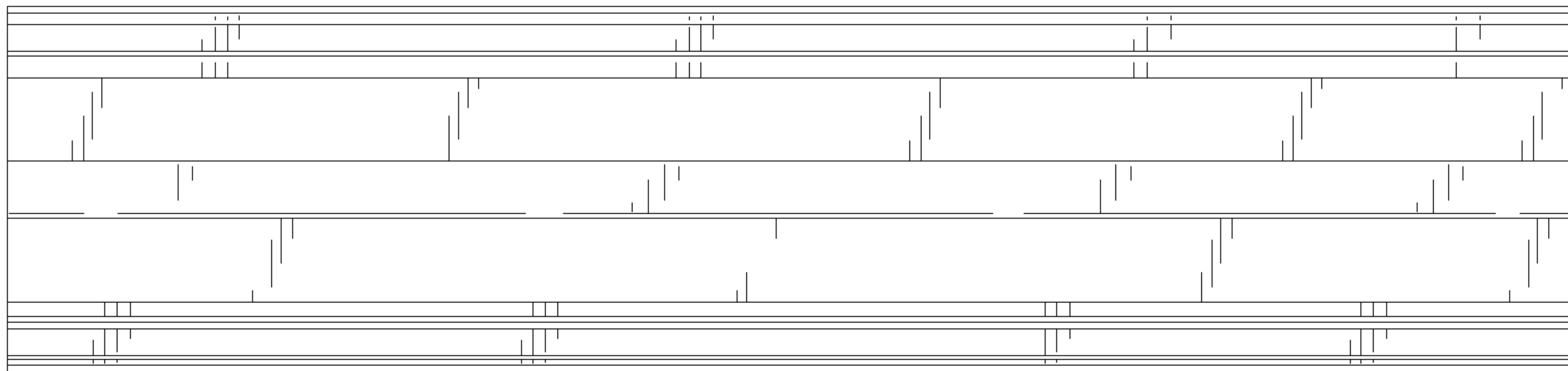
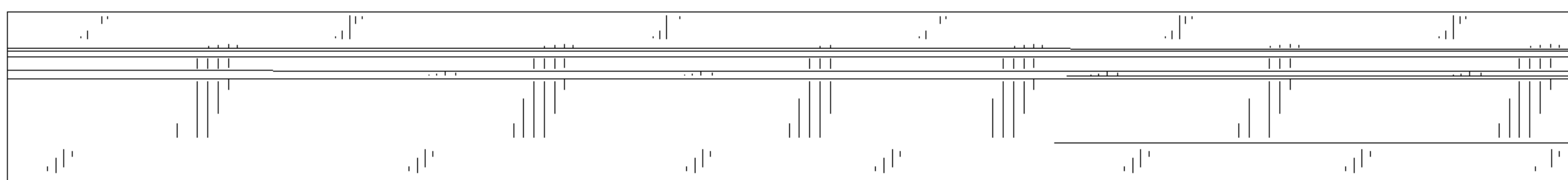

FIG. 2



**FIG. 3**



**FIG. 4**

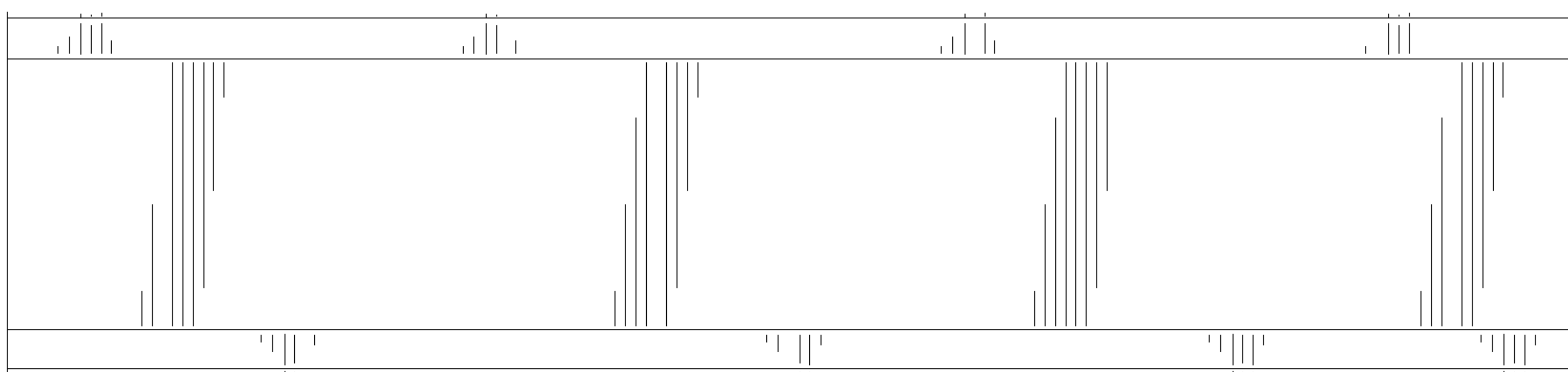

**FIG. 5**