



US00D578436S

(12) **United States Design Patent**  
**Tsuchiya**

(10) **Patent No.:** **US D578,436 S**

(45) **Date of Patent:** **\*\* \*Oct. 14, 2008**

(54) **AUTOMOBILE BODY**

(75) Inventor: **Akino Tsuchiya**, Carlsbad, CA (US)

(73) Assignee: **Chrysler LLC**, Auburn Hills, MI (US)

(\*) Notice: This patent is subject to a terminal disclaimer.

(\*\*) Term: **14 Years**

(21) Appl. No.: **29/280,050**

(22) Filed: **May 15, 2007**

**Related U.S. Application Data**

(63) Continuation of application No. 29/237,500, filed on Sep. 1, 2005, now Pat. No. Des. 551,594.

(51) **LOC (8) Cl.** ..... **12-08**

(52) **U.S. Cl.** ..... **D12/90**

(58) **Field of Classification Search** ..... D12/90-92,  
D12/86; 296/181.1, 181.5

See application file for complete search history.

(56) **References Cited**

**U.S. PATENT DOCUMENTS**

D392,920 S 3/1998 Verduyn et al.

D432,948 S 10/2000 Verduyn et al.

D457,107 S 5/2002 Kember et al.

D505,097 S 5/2005 Rodriguez

D511,482 S 11/2005 Warkuss et al.

D525,562 S 7/2006 Yagi et al.

*Primary Examiner*—Melody N Brown

(74) *Attorney, Agent, or Firm*—Ralph E. Smith

(57) **CLAIM**

The ornamental design for an automobile body, as shown and described.

**DESCRIPTION**

FIG. 1 is a front and right side perspective view of an automobile body showing my new design;

FIG. 2 is a left side view thereof;

FIG. 3 is a right side view thereof;

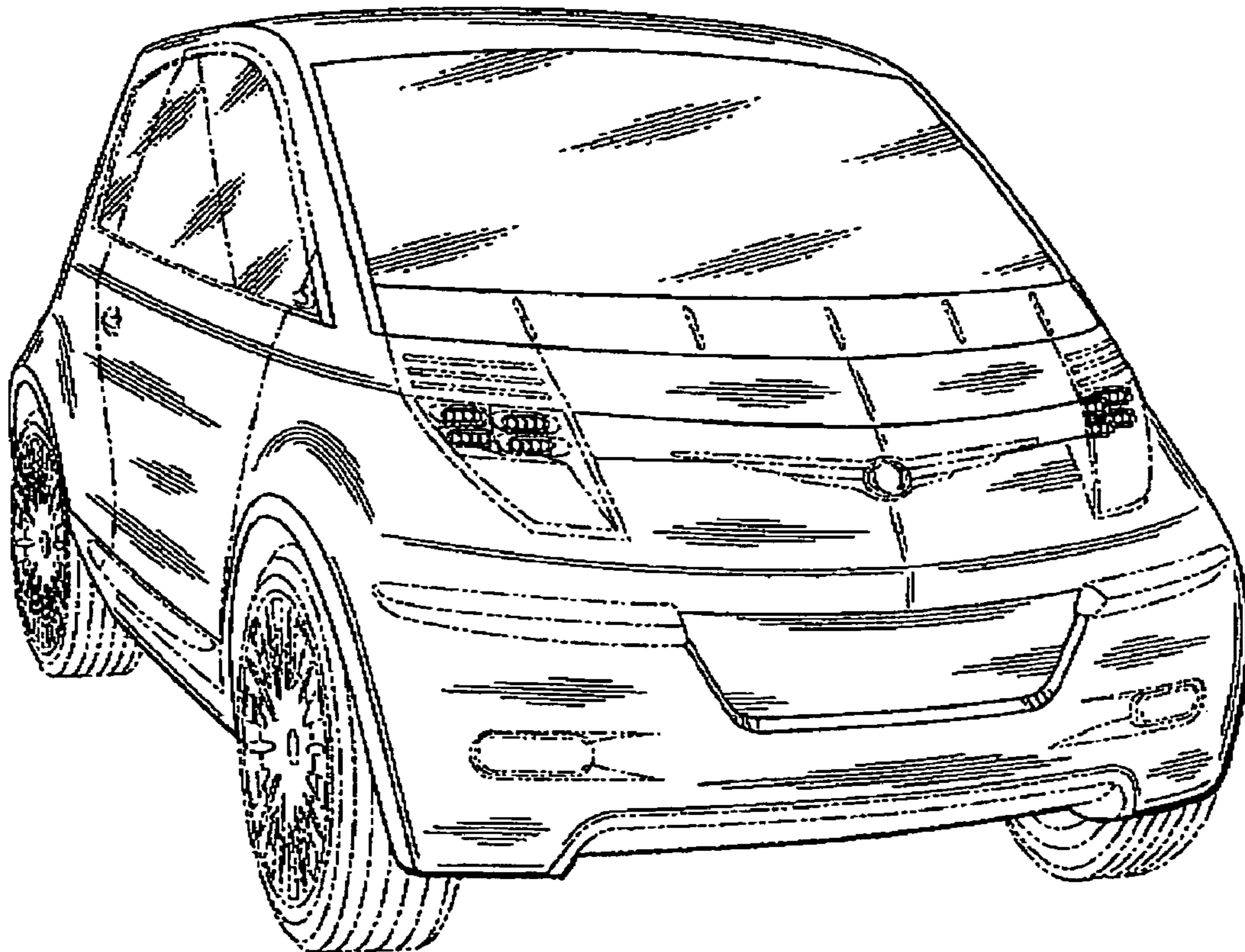
FIG. 4 is a front view thereof;

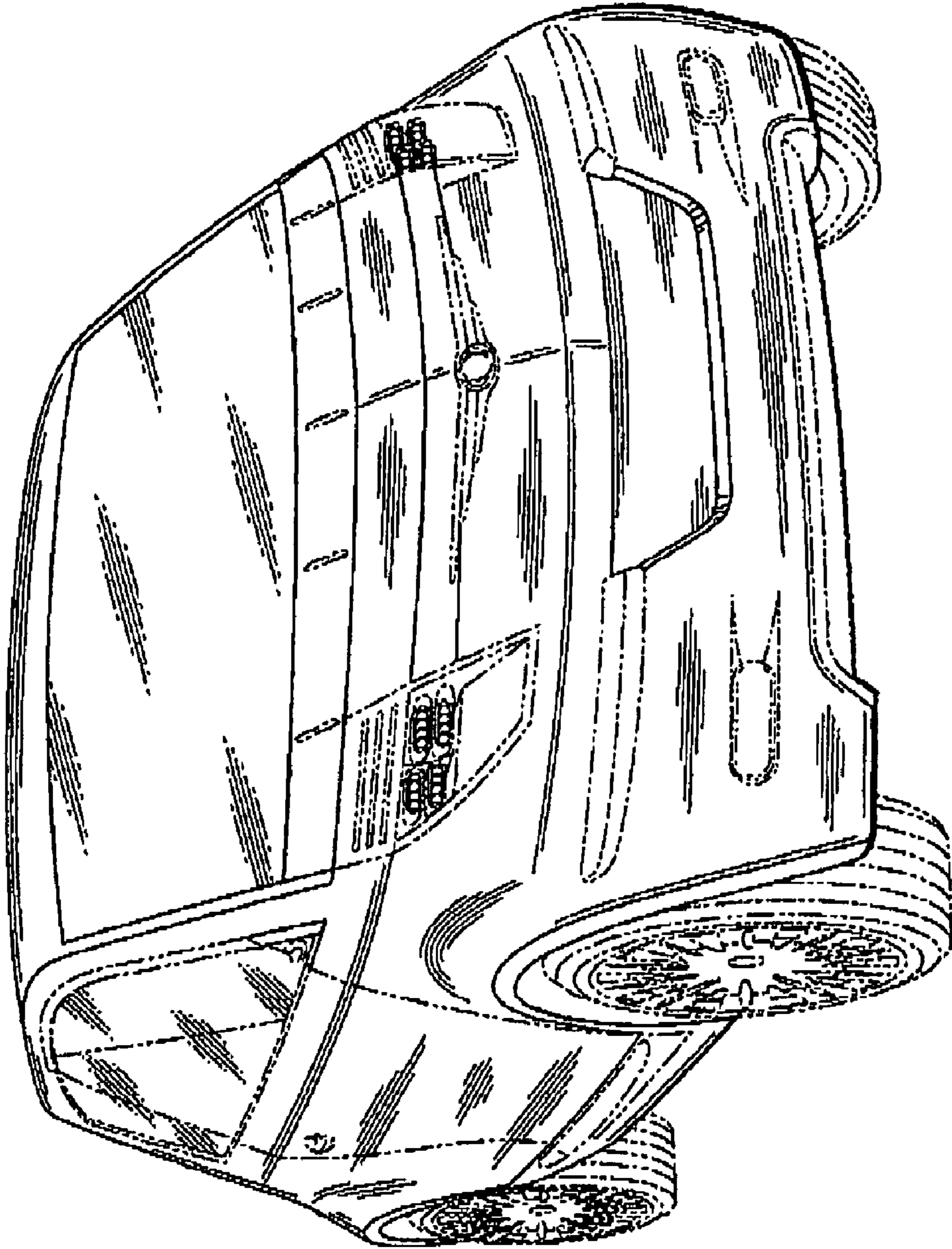
FIG. 5 is a rear view thereof; and,

FIG. 6 is a top plan view thereof.

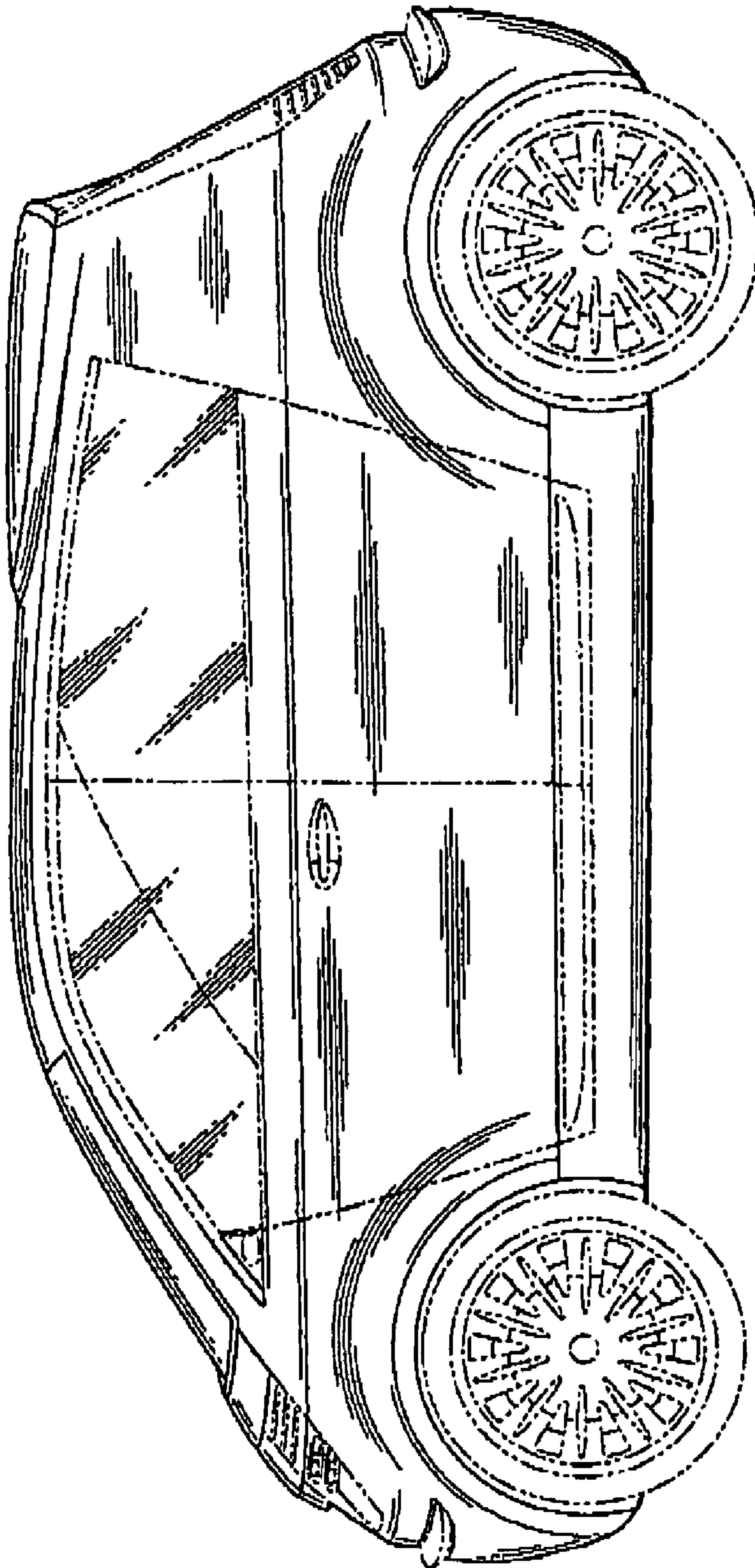
It will be understood that the broken lines presented in the drawings are for illustration only, and do not form a part of the claimed design.

**1 Claim, 5 Drawing Sheets**

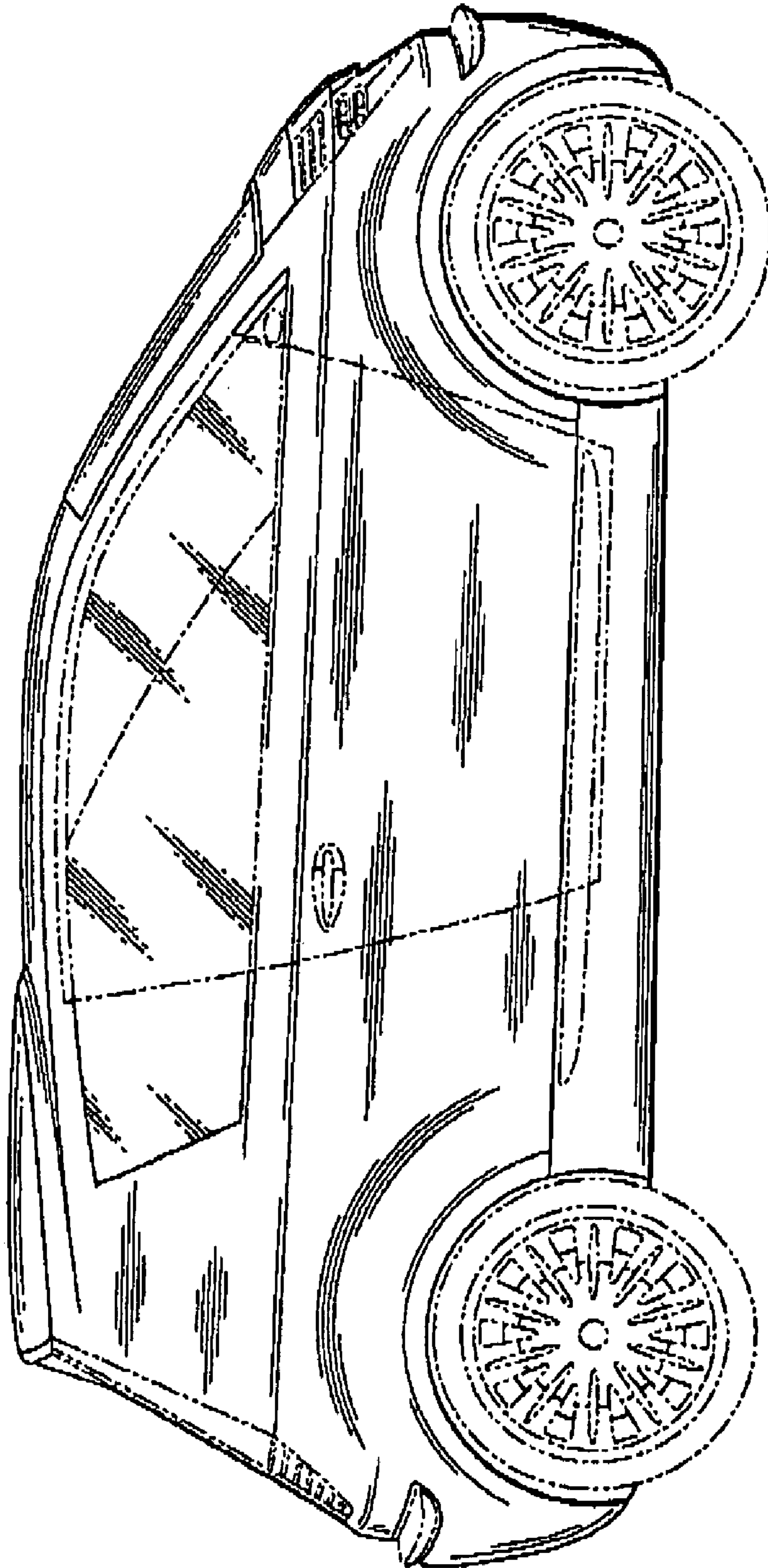




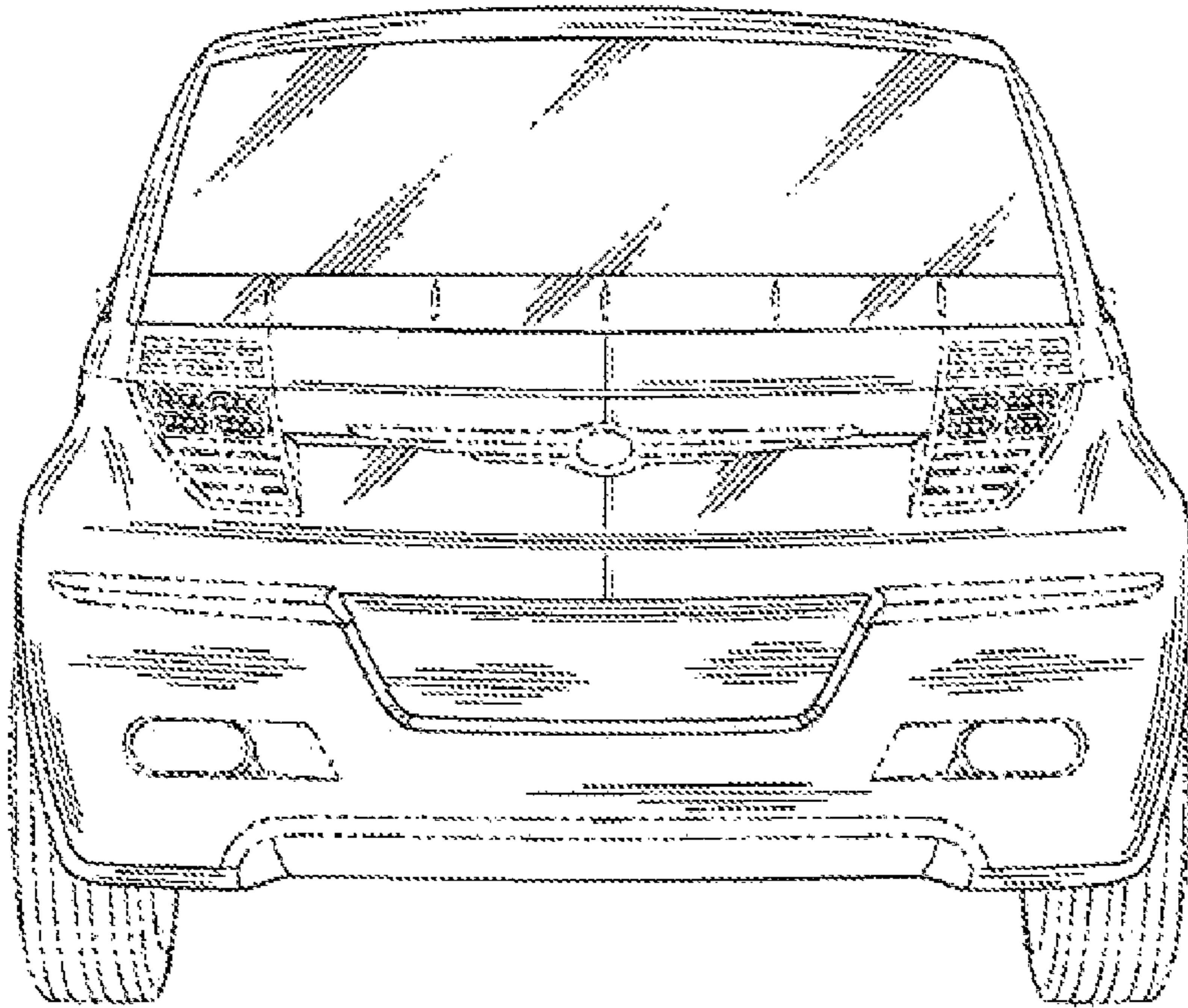
*Fig. 1*



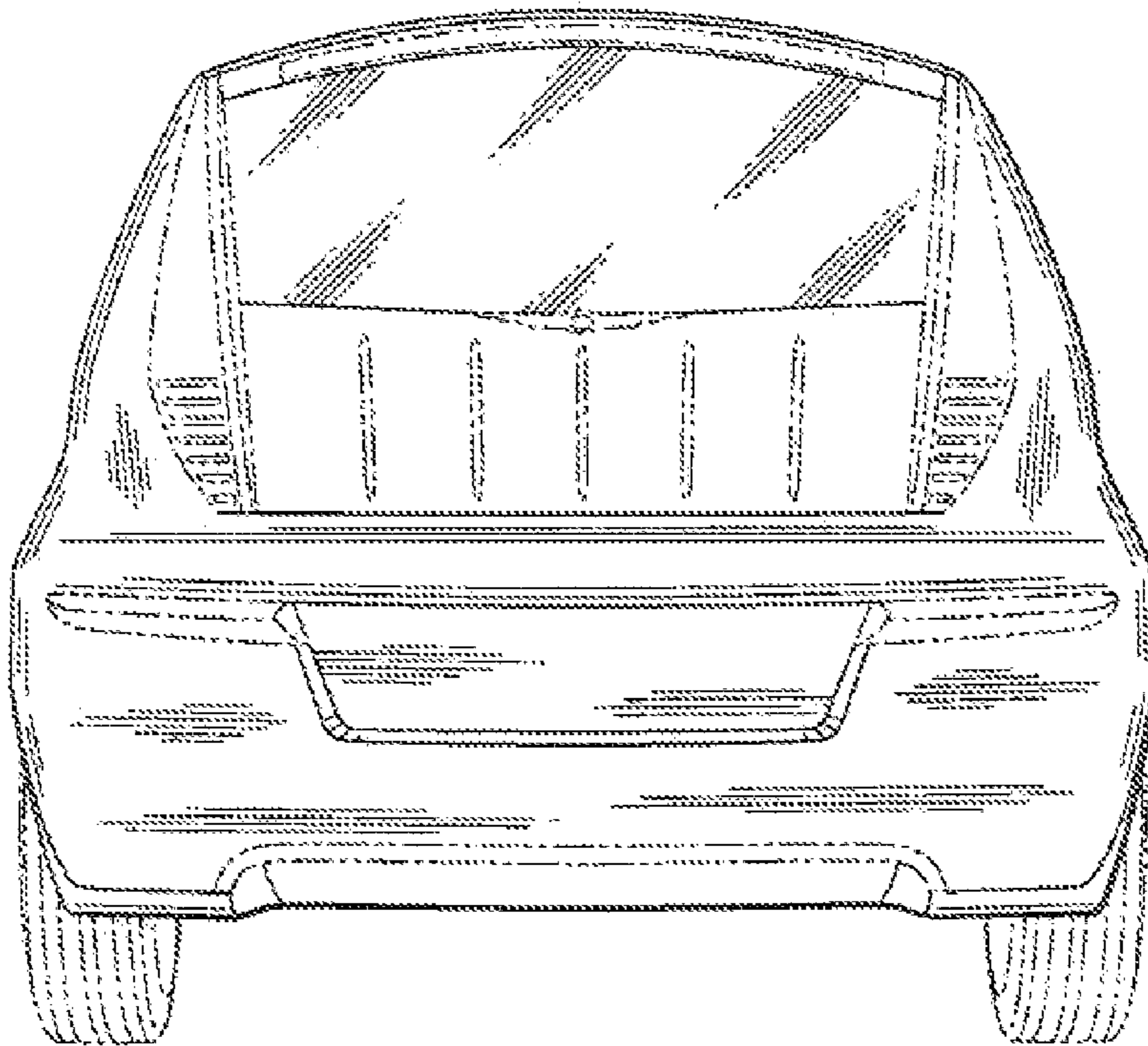
*Fig. 2*



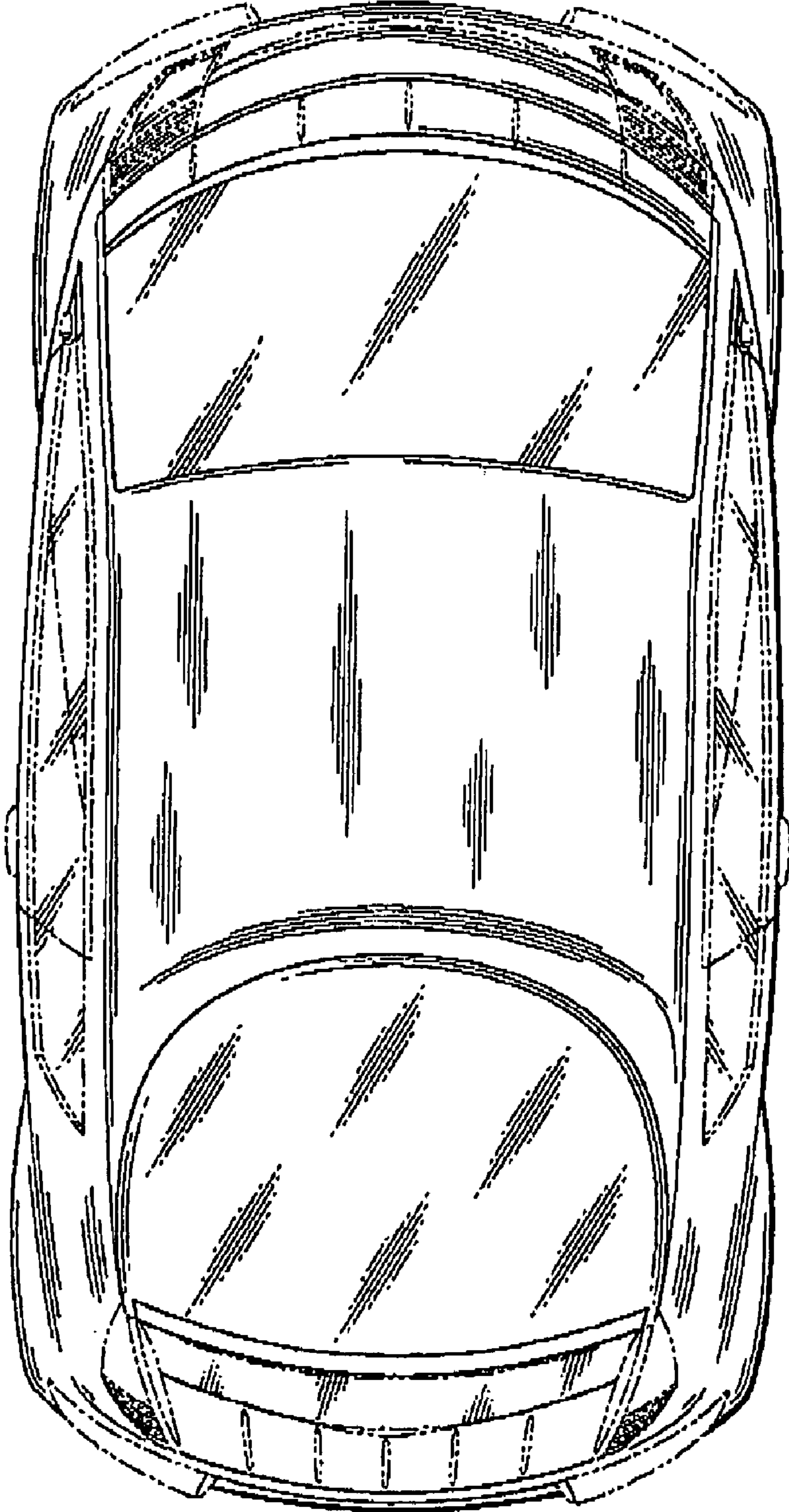
*Fig. 3*



*Fig. 4*



*Fig. 5*



*Fig. 6*