



US00D578362S

(12) **United States Design Patent**  
**McCartney**

(10) **Patent No.:** **US D578,362 S**  
(45) **Date of Patent:** **\*\* Oct. 14, 2008**

(54) **LUG BOLT WRENCH WITH STEP PAD**

(76) Inventor: **Andrew McCartney**, 10643 Nassau Ave., Sunland, CA (US) 91040

(\*\*) Term: **14 Years**

(21) Appl. No.: **29/292,205**

(22) Filed: **Oct. 1, 2007**

**Related U.S. Application Data**

(63) Continuation-in-part of application No. 29/257,081, filed on Mar. 28, 2006, now Pat. No. Des. 551,926.

(51) **LOC (8) Cl.** ..... **08-05**

(52) **U.S. Cl.** ..... **D8/26**

(58) **Field of Classification Search** ..... D8/17, D8/107, 21-29; 81/58-63.2, 120, 123, 177.1, 81/177.8, 489, 125.1, 177.85, 186, 121.1, 81/436, 124.3, 124.4, 124.6, 124.7, 165-170, 81/110.1, 309, 486, 176.2, 125, 124.2, 124.1, 81/176.1, 176.15, 177.2, 177.9, 185.1; 16/110.1; D15/144.1; 219/75, 227, 229, 121.16, 121.18, 219/119-120, 177.6; 206/378

See application file for complete search history.

(56) **References Cited**

**U.S. PATENT DOCUMENTS**

- 2,619,320 A \* 11/1952 Miller ..... 254/131
- 3,158,050 A 11/1964 Shandel
- 3,973,283 A 8/1976 Boe
- 4,291,425 A 9/1981 Sweitzer
- 4,537,101 A 8/1985 Eversole

- 4,625,600 A 12/1986 Koren et al.
- D322,202 S 12/1991 McIntyre
- D327,397 S \* 6/1992 McIntyre ..... D8/21
- D352,876 S \* 11/1994 Munson ..... D8/21
- D362,876 S 10/1995 Pedersen
- D363,419 S 10/1995 Dixon
- 5,613,411 A 3/1997 Rines
- 5,967,005 A 10/1999 DeVore et al.
- 6,769,333 B2 8/2004 Keady
- 7,080,580 B2 \* 7/2006 Gordon ..... 81/124.7

\* cited by examiner

*Primary Examiner*—Philip S. Hyder

*Assistant Examiner*—Randall H Gholson

(74) *Attorney, Agent, or Firm*—Cislo & Thomas, LLP

(57) **CLAIM**

I claim the ornamental design for a lug bolt wrench with step pad, as shown and described herein.

**DESCRIPTION**

FIG. 1. Is a perspective view of my lug bolt wrench with step pad;

FIG. 2. Is a top view thereof;

FIG. 3. Is a bottom view thereof;

FIG. 4. Is a left view thereof;

FIG. 5. Is a front view thereof; and,

FIG. 6. Is a right view thereof.

The broken line portions of the disclosure are for illustrative purposes only and form no part of the claimed design.

**1 Claim, 2 Drawing Sheets**

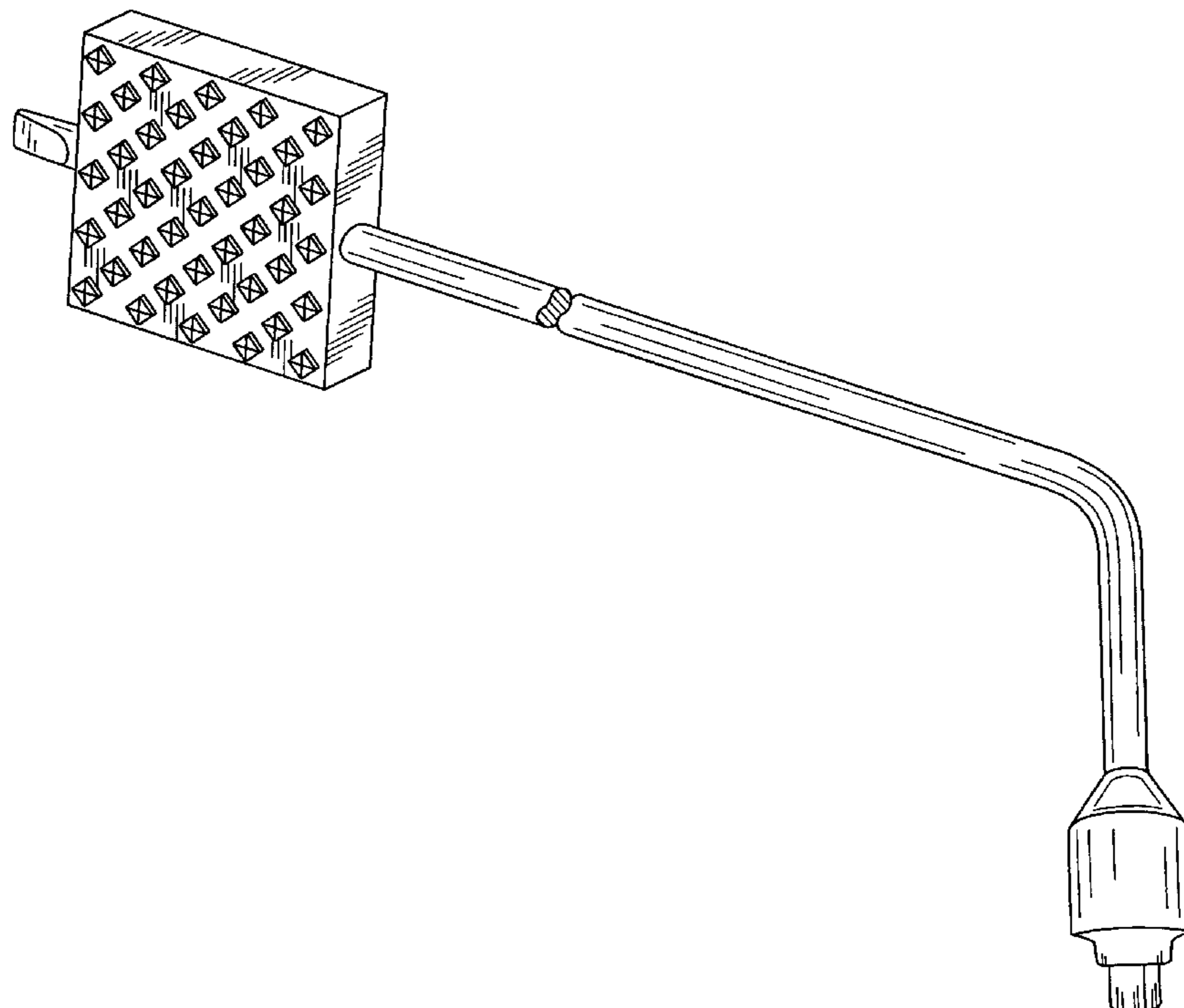

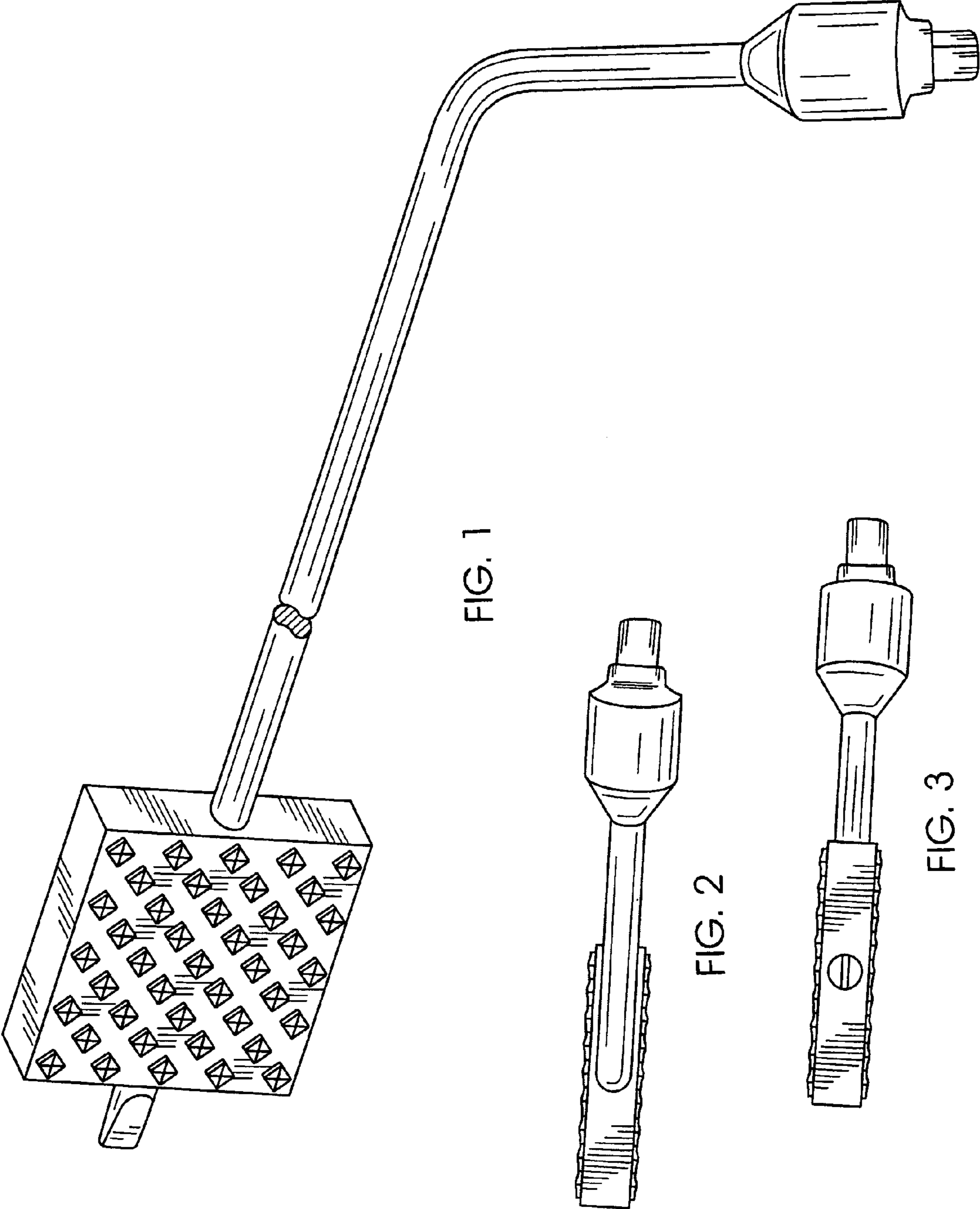

FIG. 1

FIG. 2

FIG. 3

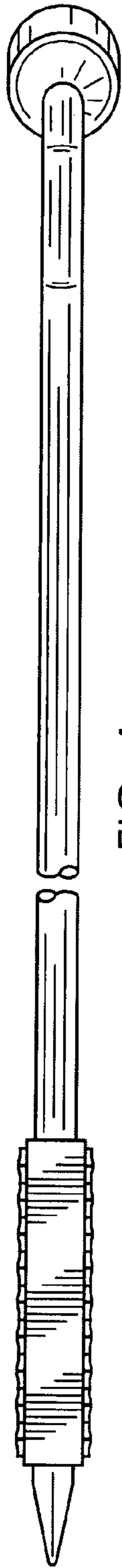

FIG. 4

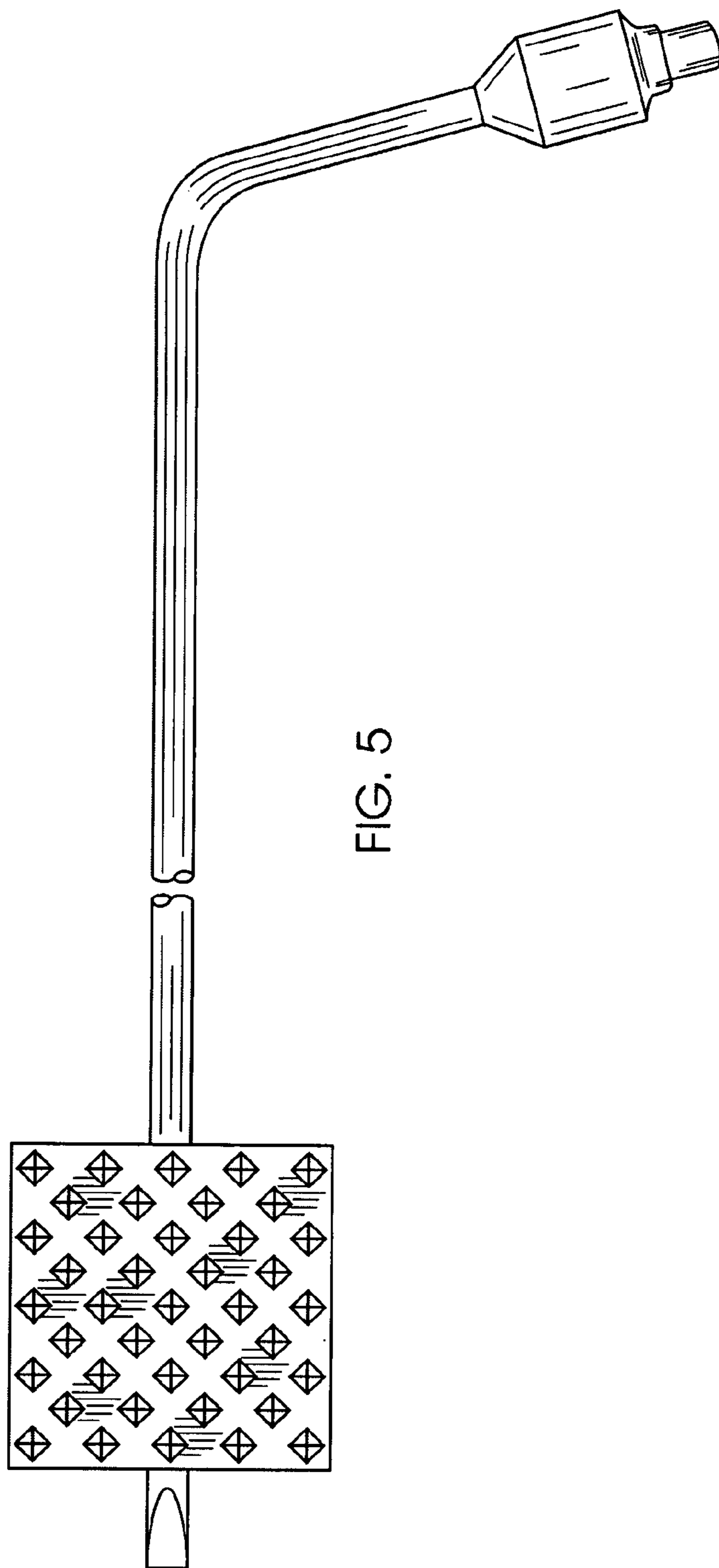

FIG. 5

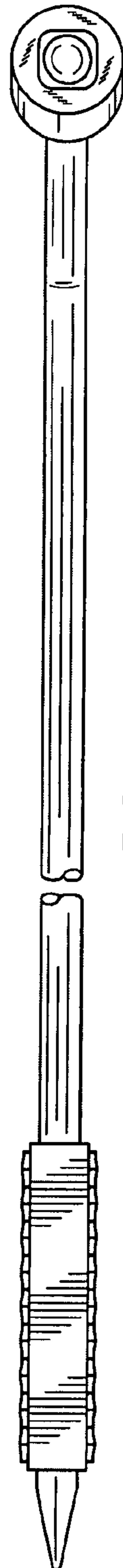

FIG. 6