



US00D577646S

(12) **United States Design Patent**
Wyszogrod et al.

(10) **Patent No.:** **US D577,646 S**

(45) **Date of Patent:** **** Sep. 30, 2008**

(54) **VEHICLE DOOR INTERIOR**

(75) Inventors: **Jose Wyszogrod**, Los Angeles, CA (US);
Hiroki Shigehara, Palos Verdes, CA
(US); **Devon Fujioka**, Los Angeles, CA
(US)

(73) Assignee: **Honda Motor Co., Ltd.**, Tokyo (JP)

(**) Term: **14 Years**

(21) Appl. No.: **29/299,346**

(22) Filed: **Dec. 21, 2007**

(51) **LOC (8) Cl.** **12-08**

(52) **U.S. Cl.** **D12/195**

(58) **Field of Classification Search** D12/190,
D12/195, 196; 49/501-502; 296/37.1-37.13,
296/149, 146.1, 153; D8/302-303
See application file for complete search history.

(56) **References Cited**

U.S. PATENT DOCUMENTS

D433,978 S * 11/2000 Tsay D12/195
D489,304 S * 5/2004 Schowalter et al. D12/195

D493,399 S * 7/2004 Schowalter et al. D12/195
D497,337 S * 10/2004 Takagi et al. D12/195
D521,917 S * 5/2006 Takagi et al. D12/195
D531,101 S * 10/2006 Yu et al. D12/195
D534,470 S * 1/2007 Tsuchiya et al. D12/195

* cited by examiner

Primary Examiner—Stacia Cadmus

(74) *Attorney, Agent, or Firm*—Plumsea Law Group, LLC;
Mark E. Duell

(57) **CLAIM**

The ornamental design for a vehicle door interior, as shown
and described.

DESCRIPTION

FIG. 1 is an elevational view of a vehicle door interior show-
ing my new design;

FIG. 2 is a perspective view thereof; and,

FIG. 3 is an end elevational view thereof.

The broken line showings of the rectangles within the claimed
area, and the boundary of the claim itself in FIG. 3 are for
illustrative purposes and form no part of the claimed design.

1 Claim, 2 Drawing Sheets

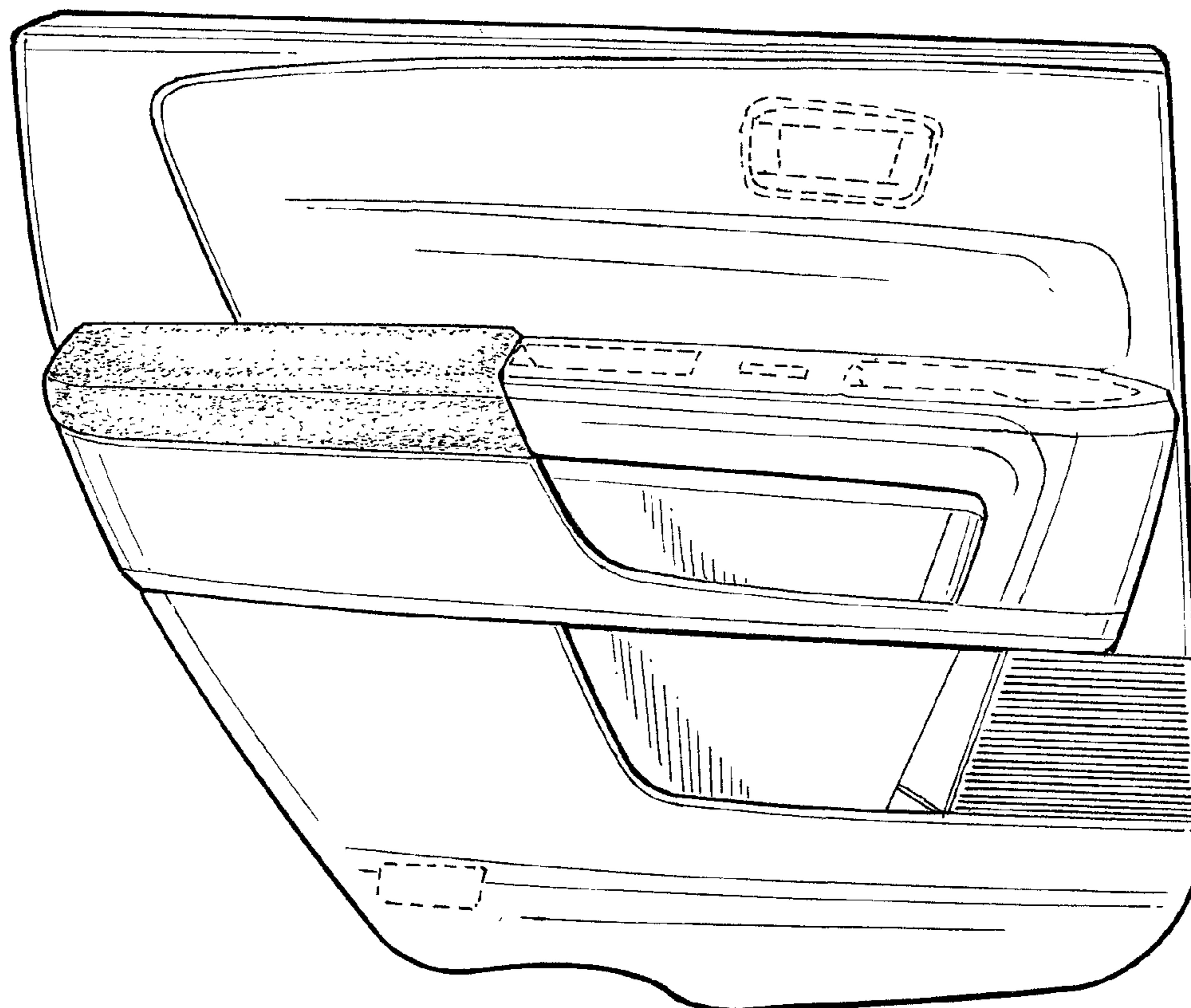

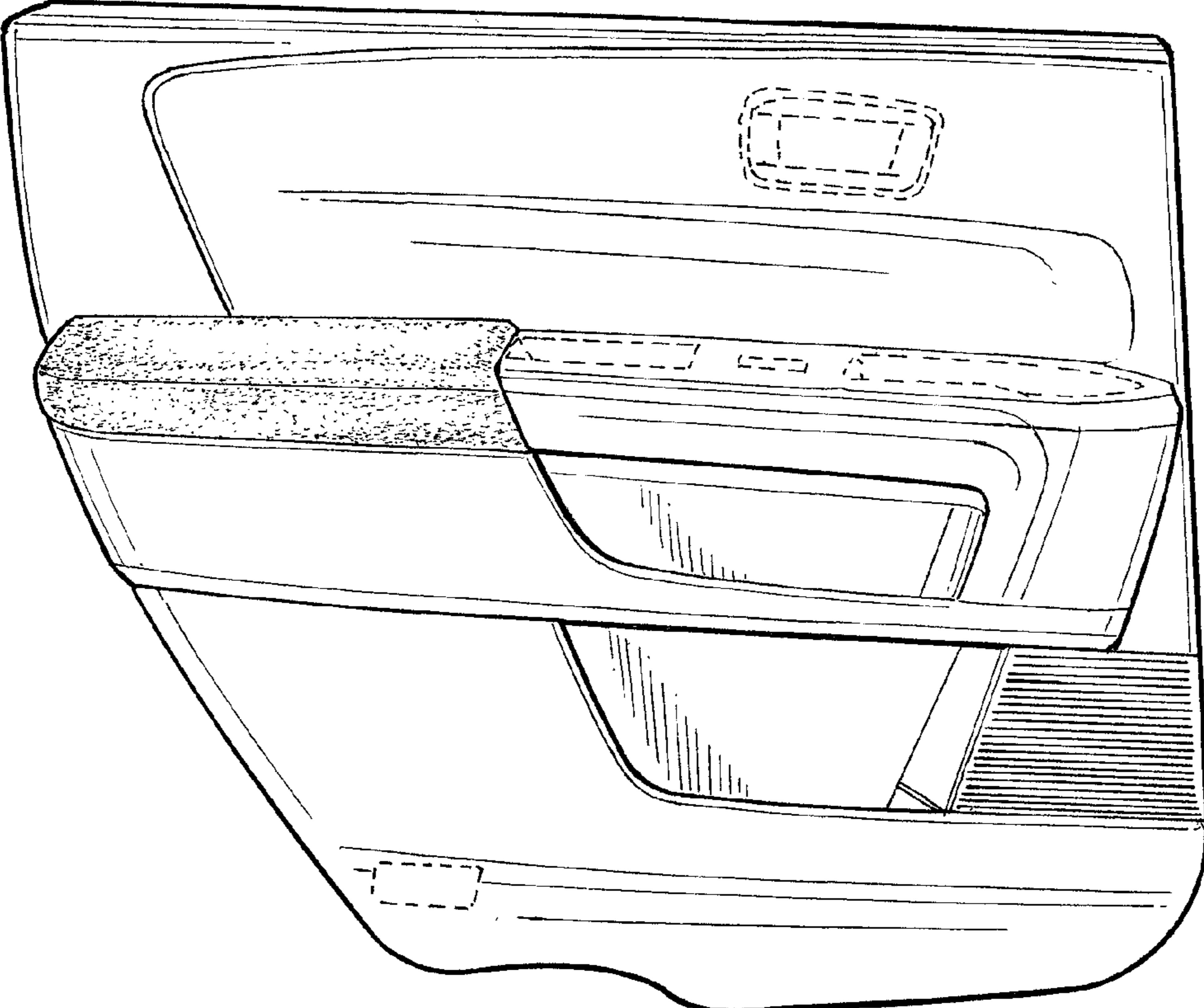

FIG. 1

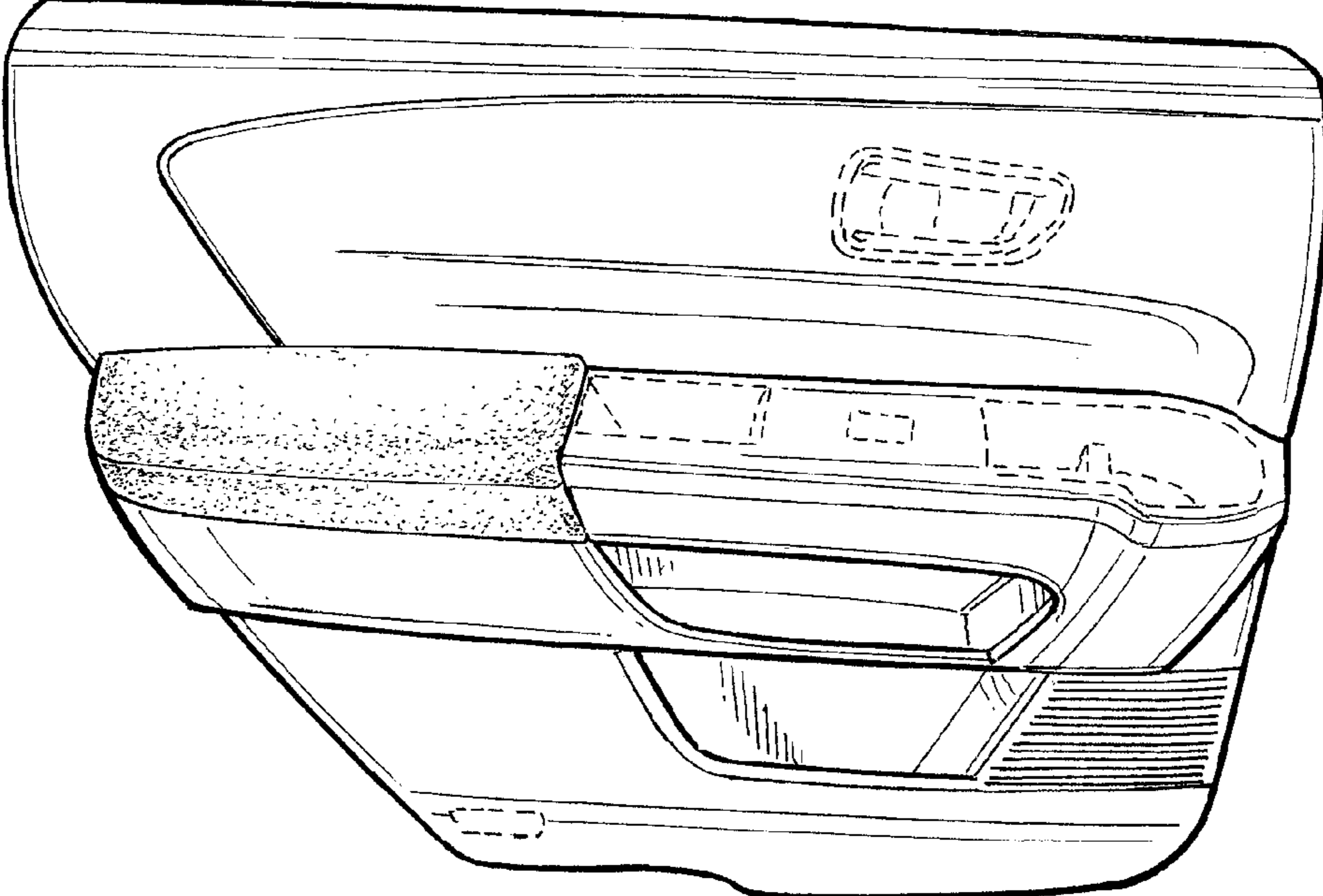

FIG. 2

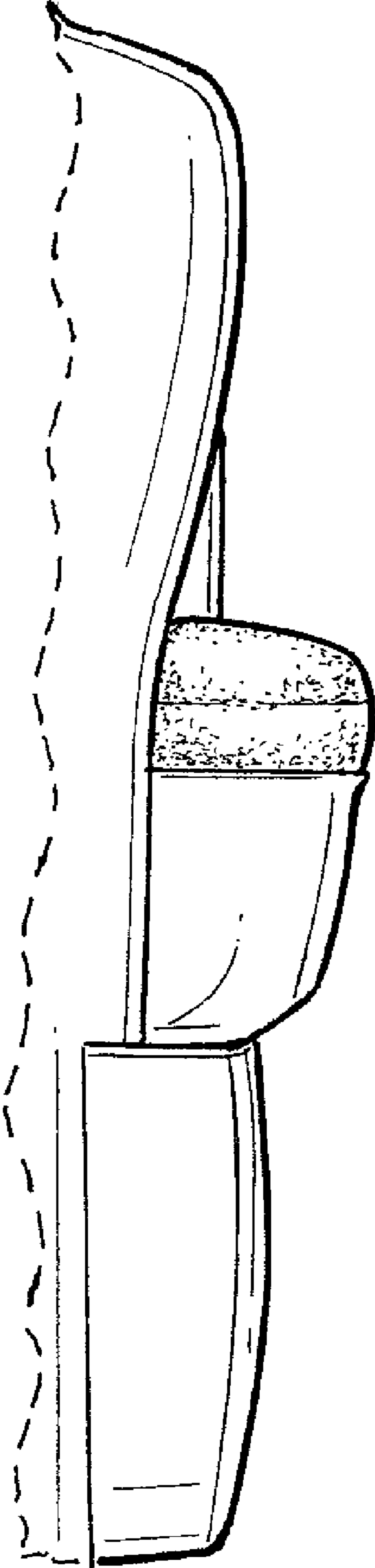

FIG. 3