



US00D577557S

(12) **United States Design Patent**  
**Shimokawa et al.**

(10) **Patent No.:** **US D577,557 S**

(45) **Date of Patent:** **\*\* Sep. 30, 2008**

(54) **MAIN BODY OF A PORTABLE CHAIN SAW**

(75) Inventors: **Kouichi Shimokawa**, Kawagoe (JP);  
**Kiminobu Satou**, Kawagoe (JP);  
**Kiyoshi Anbo**, Kawagoe (JP)

(73) Assignee: **Husqvarna Zenoah Co., Ltd.**,  
Kawagoe-shi (JP)

(\*\*) Term: **14 Years**

(21) Appl. No.: **29/299,257**

(22) Filed: **Dec. 20, 2007**

(30) **Foreign Application Priority Data**

Jun. 20, 2007 (JP) ..... 2007-016486

(51) **LOC (8) Cl.** ..... **08-03**

(52) **U.S. Cl.** ..... **D8/65**

(58) **Field of Classification Search** ..... D8/7,  
D8/8, 9, 68, 70, 65, 66, 67, 62, 63, 64, 61;  
30/386, 383, 382, 371, 123; 125/21, 1 R  
See application file for complete search history.

(56) **References Cited**

**U.S. PATENT DOCUMENTS**

D176,963	S	*	2/1956	Mall et al.	.....	D15/1
4,630,372	A	*	12/1986	Nagashima	.....	30/381
4,654,970	A	*	4/1987	Nagashima	.....	30/383
4,662,071	A	*	5/1987	Hoppner et al.	.....	30/381
H000378	H	*	12/1987	Matsumoto	.....	30/382
4,753,012	A	*	6/1988	Schurr	.....	30/382
D320,728	S	*	10/1991	Arvidsson	.....	D8/65
5,070,618	A	*	12/1991	Edlund	.....	30/386
D361,251	S	*	8/1995	Griffin	.....	D8/65
D364,326	S	*	11/1995	Lohse et al.	.....	D8/65

D377,441	S	*	1/1997	Hoppner et al.	.....	D8/65
D378,184	S	*	2/1997	Naslund et al.	.....	D8/64
D386,958	S	*	12/1997	Karlsson et al.	.....	D8/65
D412,652	S	*	8/1999	Durr et al.	.....	D8/65
5,992,025	A	*	11/1999	Fricke	.....	30/381
6,016,604	A	*	1/2000	Wolf et al.	.....	30/383
6,637,117	B2	*	10/2003	Kobayashi	.....	30/381
6,842,987	B1	*	1/2005	Martinsson et al.	.....	30/382
D549,537	S	*	8/2007	Harada et al.	.....	D8/65
D558,019	S	*	12/2007	Granberg et al.	.....	D8/65
D558,020	S	*	12/2007	Karlsson et al.	.....	D8/65
2004/0103857	A1	*	6/2004	Kruse	.....	123/1 R

\* cited by examiner

*Primary Examiner*—Cathron Brooks

*Assistant Examiner*—Austin Murphy

(74) *Attorney, Agent, or Firm*—Synnestvedt & Lechner, LLP

(57) **CLAIM**

The ornamental design for a main body of a portable chain saw, as shown and described.

**DESCRIPTION**

FIG. 1 is a front perspective view of a main body of a portable chain saw showing our new design;

FIG. 2 is a rear perspective view thereof;

FIG. 3 is a front view thereof;

FIG. 4 is a rear view thereof;

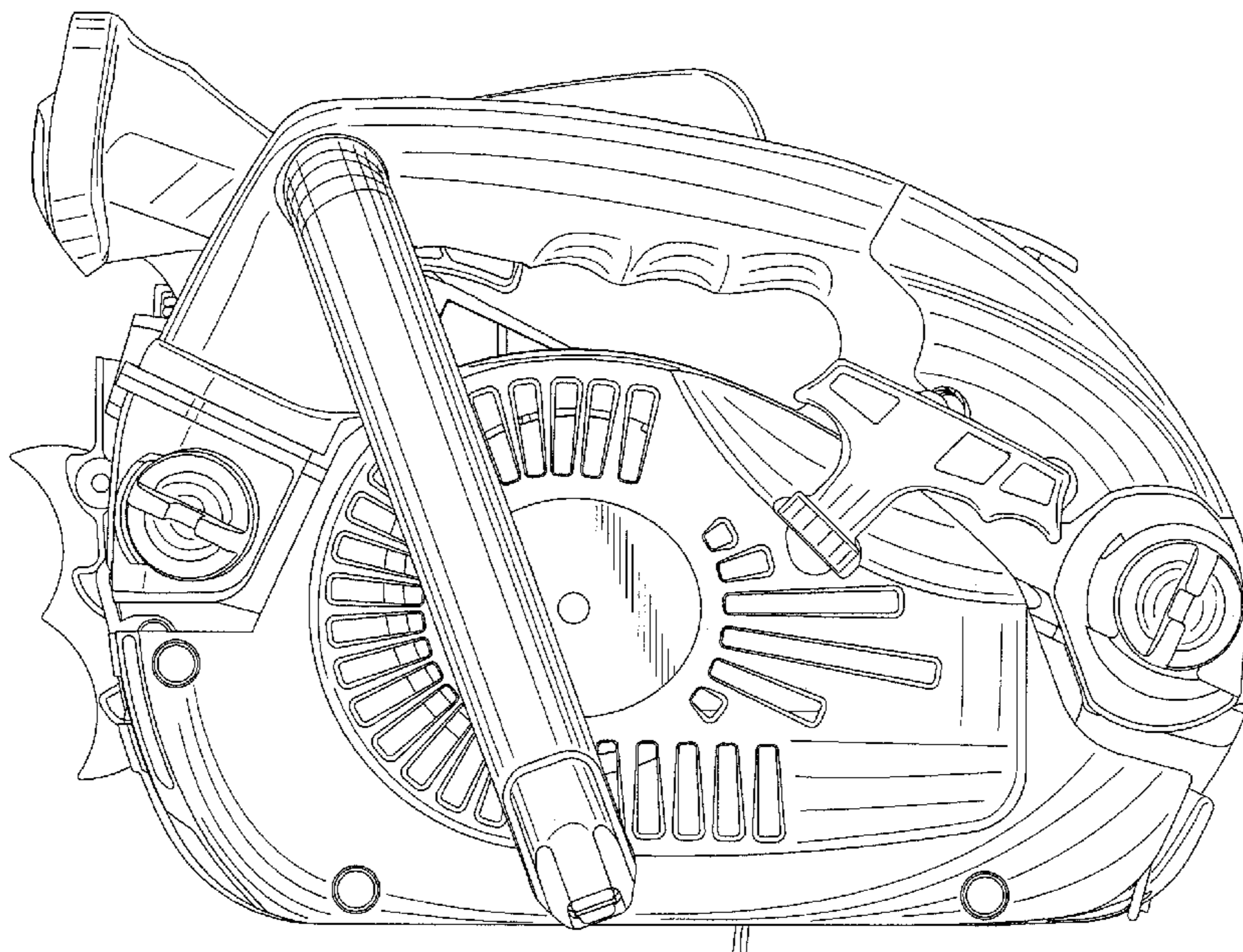
FIG. 5 is a top plan view thereof;

FIG. 6 is a bottom plan view thereof;

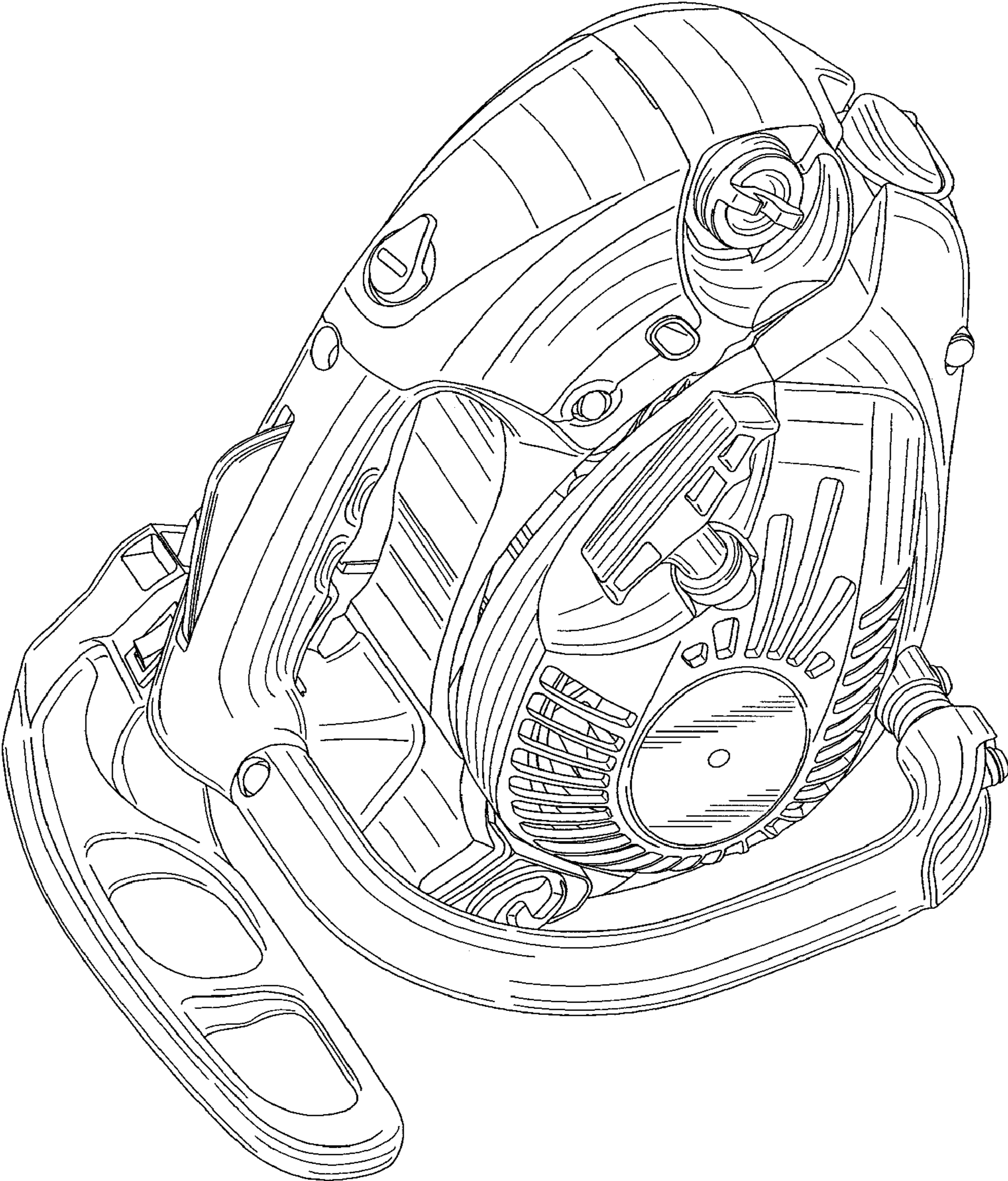
FIG. 7 is a right side view thereof; and,

FIG. 8 is a left side view thereof.

**1 Claim, 8 Drawing Sheets**

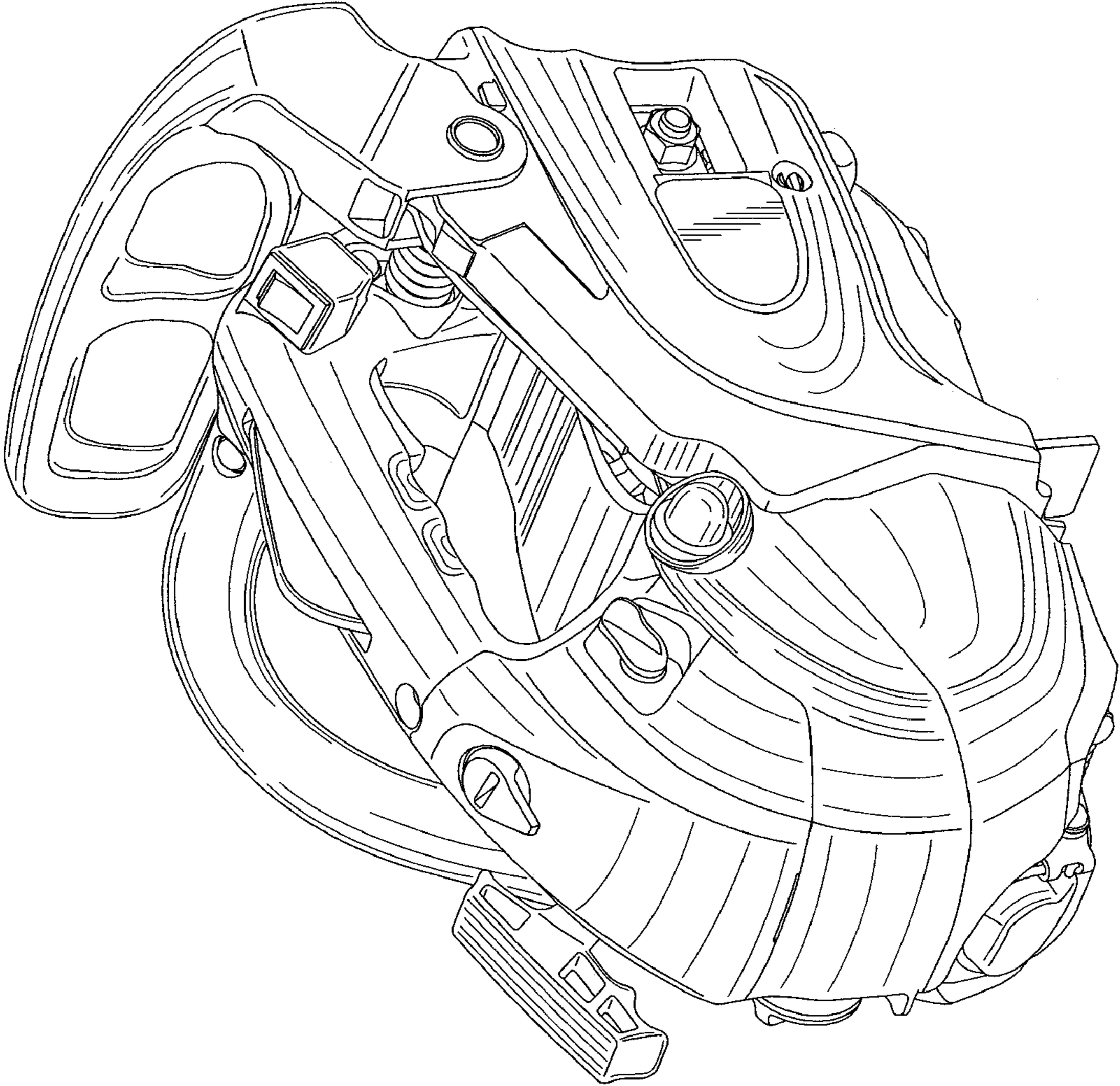


**FIG. 1**

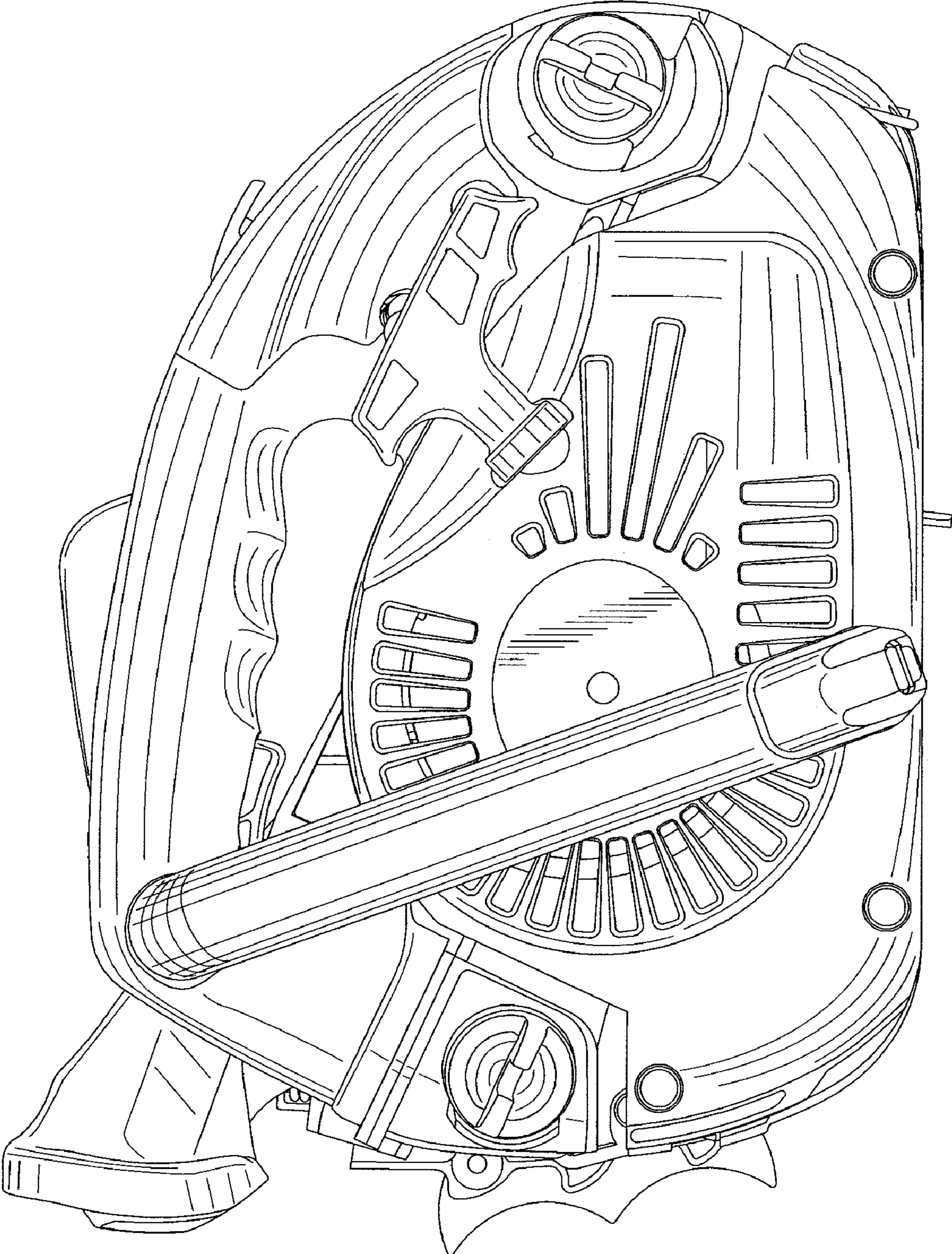




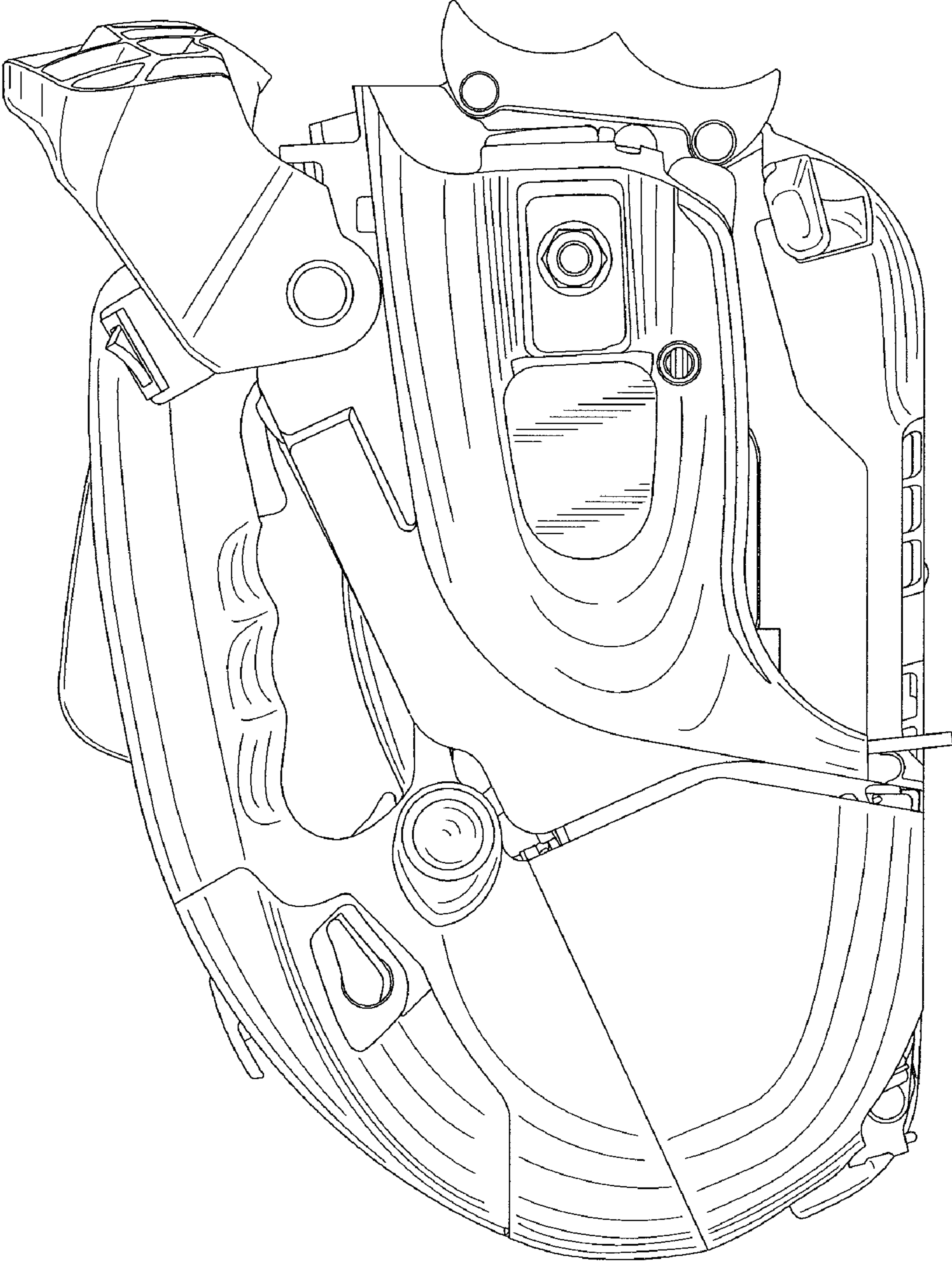
**FIG. 2**



**FIG. 3**

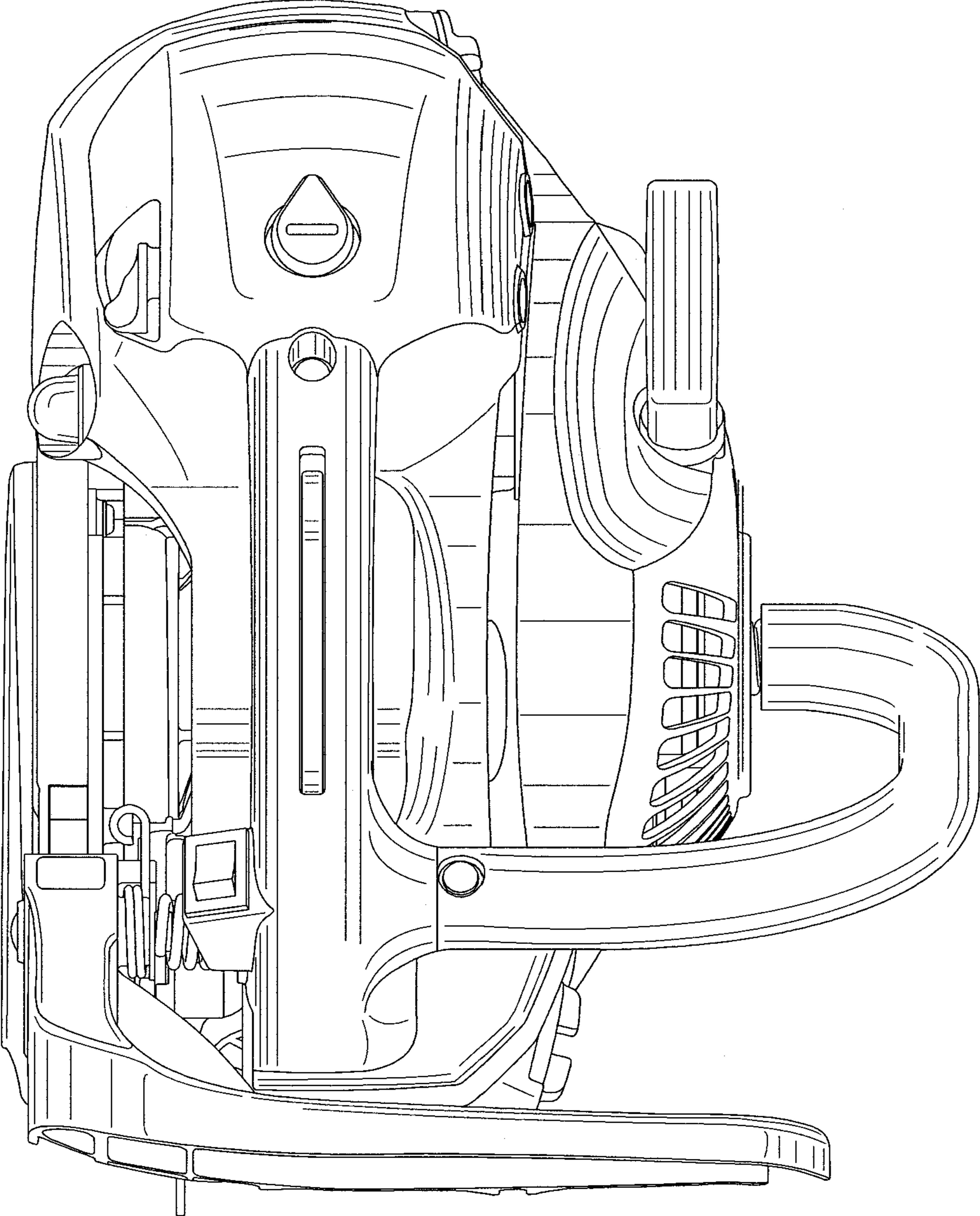


**FIG. 4**

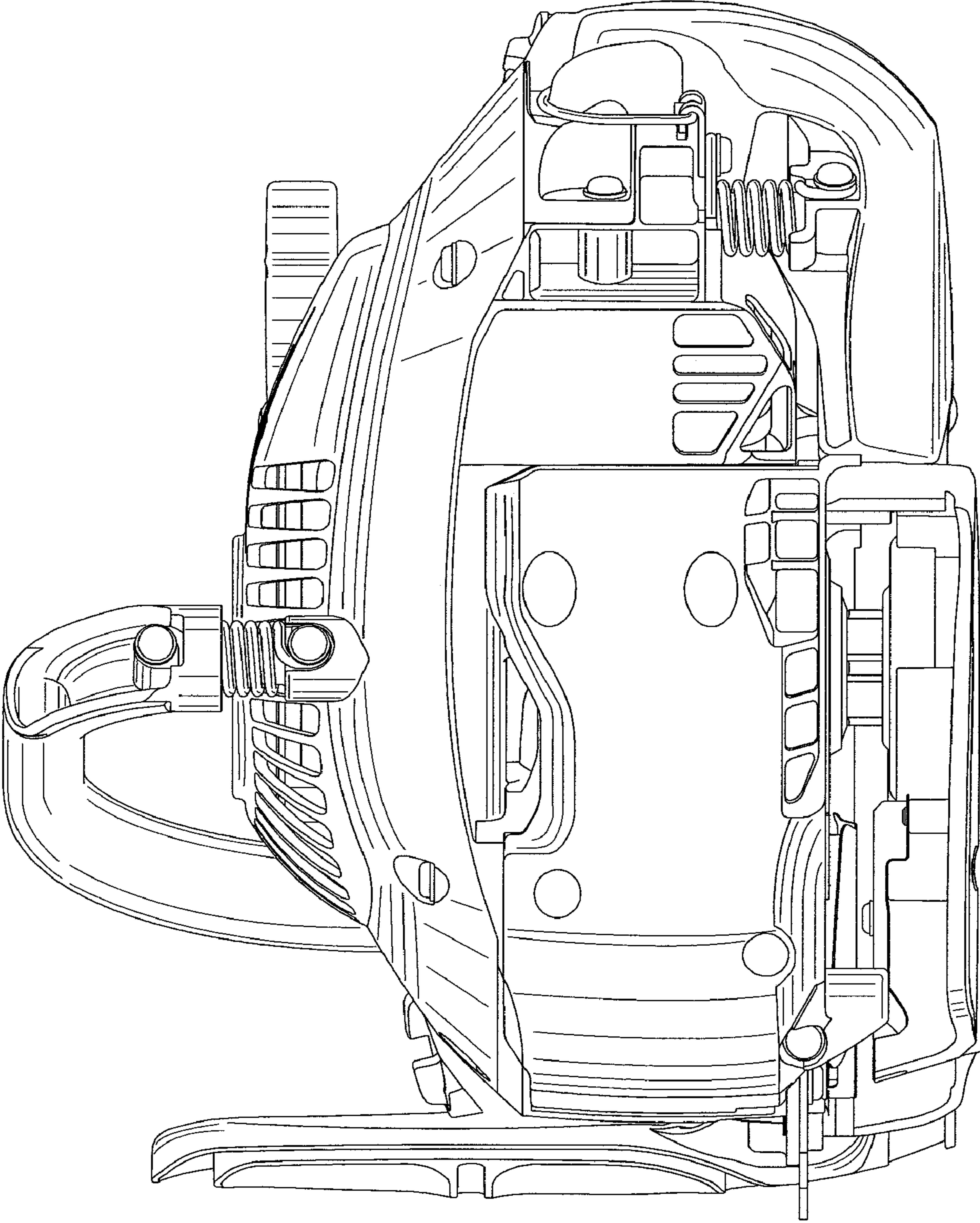




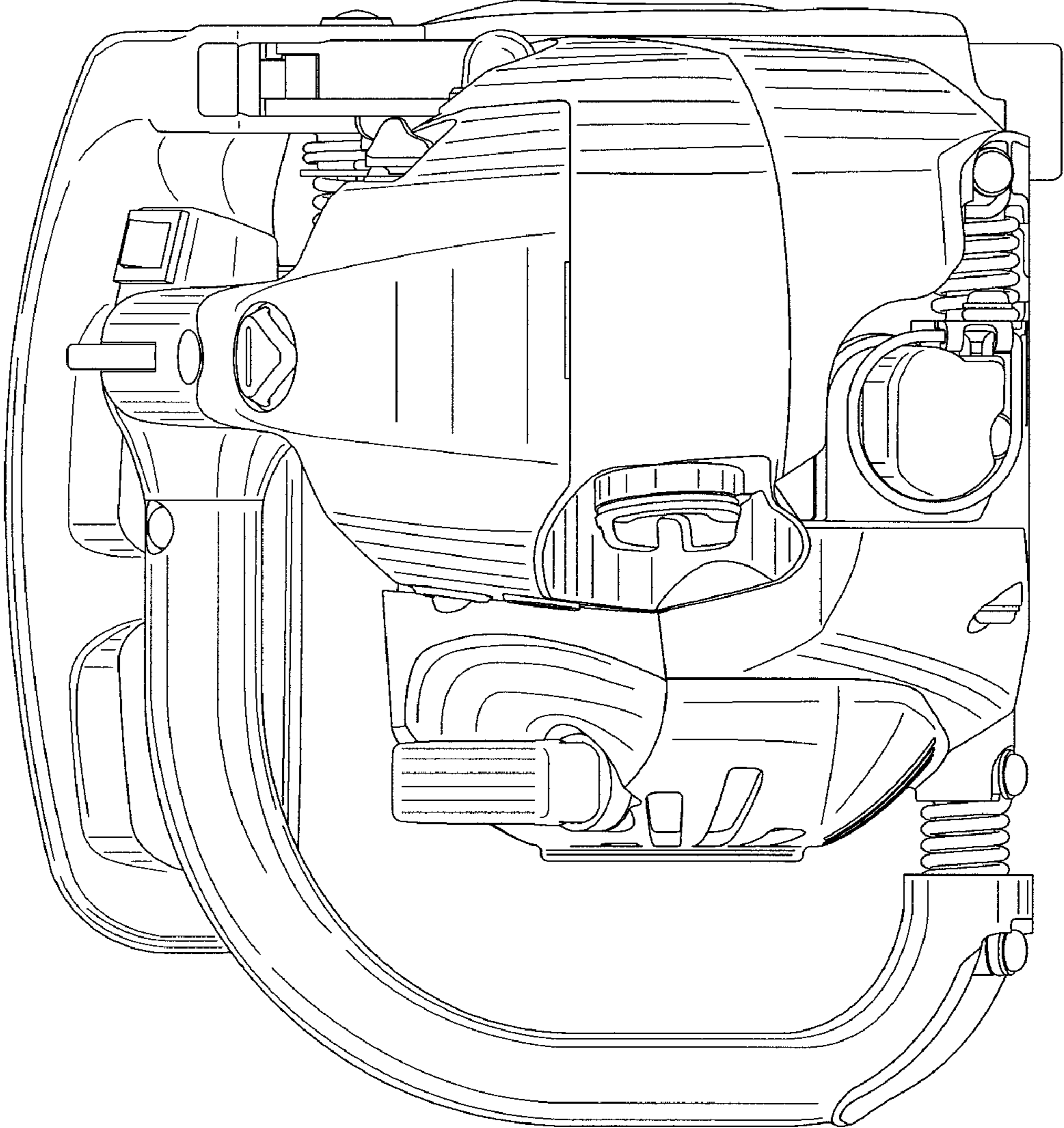
**FIG. 5**



**FIG. 6**



**FIG. 7**





**FIG. 8**

