

US00D577412S

(12) **United States Design Patent**
Nathan et al.

(10) **Patent No.:** **US D577,412 S**
(45) **Date of Patent:** **** Sep. 23, 2008**

- (54) **RODENT TRAP**
 - (75) Inventors: **Philip Nathan**, West Hartford, CT (US);
Matthew L. Phillips, Litchfield, CT (US);
Lynn Briggs, Bristol, CT (US);
Thomas Paul Danniger, Ostrander, OH (US);
Richard Gene Foster, Powell, OH (US)
 - (73) Assignee: **SMG Brands, Inc.**, Wilmington, DE (US)
 - (**) Term: **14 Years**
 - (21) Appl. No.: **29/319,850**
 - (22) Filed: **Jun. 16, 2008**
 - (51) **LOC (8) Cl.** **22-05**
 - (52) **U.S. Cl.** **D22/119**
 - (58) **Field of Classification Search** D22/119-124;
43/58, 60-61, 68, 76, 81, 112-113, 124,
43/131, 132.1
- See application file for complete search history.

4,926,581 A	5/1990	Grivas
5,040,327 A	8/1991	Stack et al.
5,044,113 A	9/1991	Stack et al.
5,148,624 A	9/1992	Schmidt
5,172,512 A	12/1992	Bodker et al.
D346,199 S	4/1994	Spragins et al.
5,337,512 A	8/1994	Krenzler
5,384,981 A	1/1995	Cohen
5,398,442 A	3/1995	Musket
5,448,852 A	9/1995	Spragins et al.
5,471,781 A	12/1995	Vine
5,477,636 A	12/1995	Musket
5,481,824 A	1/1996	Fiore, Jr.
5,572,825 A	11/1996	Gehret
5,577,342 A	11/1996	Johnson et al.
D385,611 S	10/1997	Prince et al.
D386,554 S	11/1997	Brewer
5,692,336 A	12/1997	Fiore, Jr. et al.
5,746,020 A	5/1998	Fiore, Jr. et al.
5,806,237 A	9/1998	Nelson et al.
D409,711 S	5/1999	Johnson
5,950,353 A	9/1999	Johnson et al.
6,047,494 A	4/2000	Johnson et al.
D441,828 S	5/2001	Leyerle et al.
6,248,730 B1	6/2001	Poché
6,266,917 B1	7/2001	Hight
6,389,738 B1	5/2002	Denny et al.
D459,428 S	6/2002	Johnson et al.
6,397,517 B1	6/2002	Leyerle et al.
6,415,544 B1	7/2002	Leyerle et al.
6,481,151 B1	11/2002	Johnson et al.
6,493,988 B1	12/2002	Johnson
6,508,031 B1	1/2003	Johnson et al.
6,574,912 B1	6/2003	Johnson
6,594,948 B1	7/2003	Novack
6,609,328 B2	8/2003	Swift et al.
6,622,422 B2	9/2003	Gehret et al.
6,631,582 B2	10/2003	Knuppel et al.
D485,597 S	1/2004	Turner
6,684,560 B2	2/2004	Lafforthun
6,691,452 B1	2/2004	Knuppel et al.
6,694,669 B2	2/2004	Gehret et al.
6,735,899 B1	5/2004	Anderson et al.
6,775,947 B2	8/2004	Anderson et al.
6,796,081 B2	9/2004	Anderson et al.
6,807,768 B2	10/2004	Johnson et al.
6,836,999 B2	1/2005	Rich et al.
6,938,368 B2	9/2005	Guidry
6,955,007 B2	10/2005	Gehret et al.

(56) **References Cited**
U.S. PATENT DOCUMENTS

83,074 A	10/1868	McClure
441,677 A	12/1890	Lovell
982,486 A	1/1911	Edwards
1,281,876 A	10/1918	Taylor
D57,320 S	3/1921	Dorsch
1,587,536 A	6/1926	Lobit
1,677,470 A	7/1928	Dorsch et al.
2,529,589 A	11/1950	Biery
4,030,230 A	6/1977	Souza
4,144,667 A	3/1979	Souza
4,245,423 A	1/1981	Souza et al.
4,253,264 A	3/1981	Souza
4,769,942 A	9/1988	Copenhaver, Sr.
4,803,799 A	2/1989	Vajs et al.
D300,163 S	3/1989	Landell et al.
4,852,294 A	8/1989	Langli
4,856,225 A	8/1989	Radesky et al.
4,858,373 A	8/1989	Combs

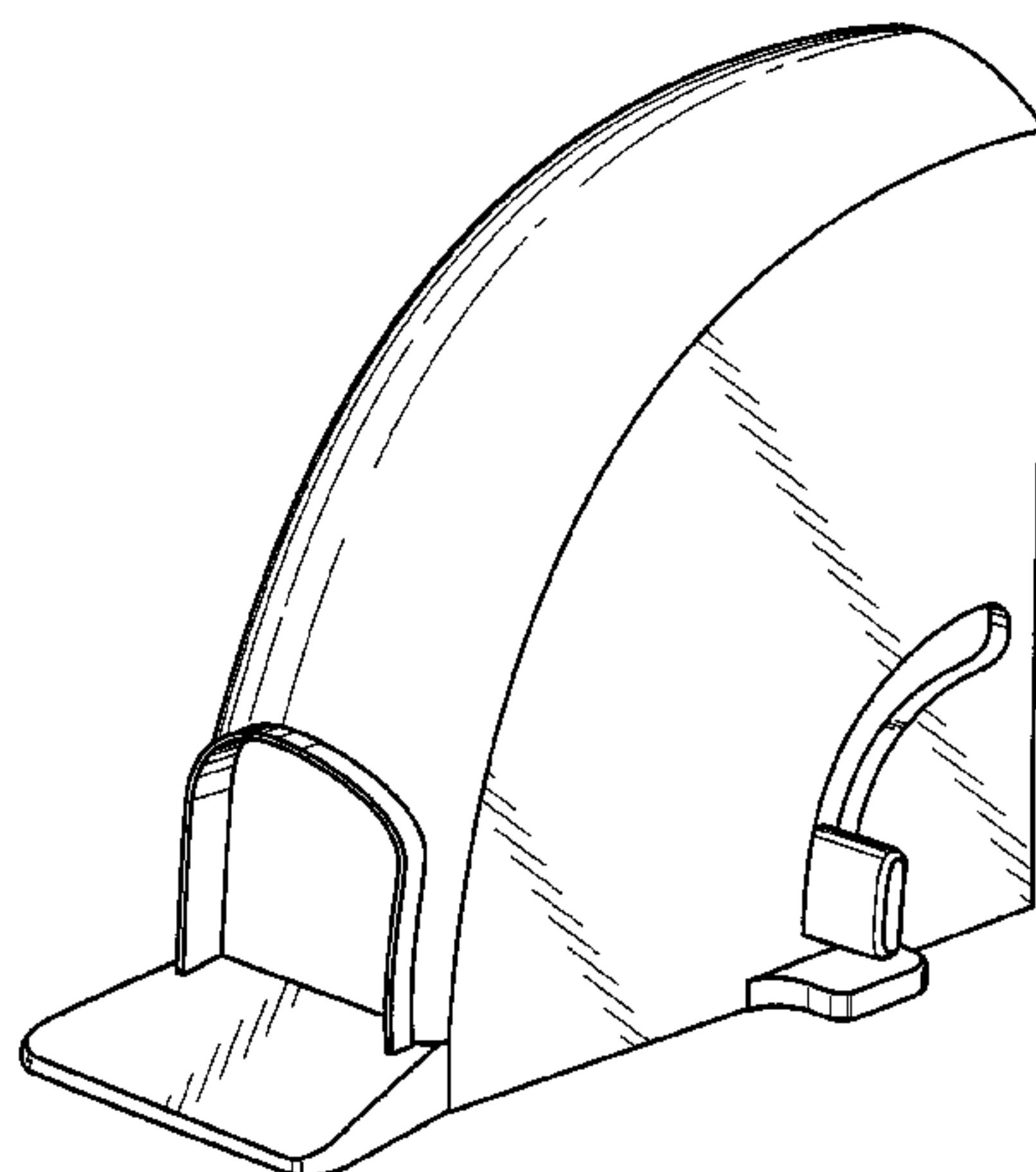

6,990,766	B2	1/2006	Gehret et al.	
D514,655	S	2/2006	Rodgers et al.	
D515,175	S	2/2006	Mayo et al.	
7,010,882	B2	3/2006	Rich et al.	
7,069,688	B2	7/2006	Hill	
7,089,701	B2	8/2006	Frisch	
D529,571	S	10/2006	Hoyes	
7,171,777	B2	2/2007	Welin-Berger	
7,219,466	B2	5/2007	Rich et al.	
7,231,738	B2	6/2007	Watson et al.	
D573,224	S *	7/2008	Rodriguez	D22/119
2003/0215481	A1	11/2003	Borchert et al.	
2004/0025410	A1	2/2004	Shapland	
2004/0088903	A1	5/2004	Poche	
2004/0244274	A1	12/2004	Dellevigne et al.	
2005/0279015	A1	12/2005	Hall	
2006/0032110	A1	2/2006	Yang	
2006/0042153	A1	3/2006	Bowerman	
2006/0053682	A1	3/2006	Goldstein	
2006/0117644	A1	6/2006	Hoyes et al.	
2006/0156615	A1	7/2006	Hale	
2006/0156617	A1	7/2006	Hale	
2006/0265941	A1	11/2006	Newton	
2006/0272197	A1	12/2006	Wiesener et al.	
2007/0017148	A1	1/2007	Blau	
2007/0017149	A1	1/2007	Rodgers et al.	

FOREIGN PATENT DOCUMENTS

EP	0280504	8/1988
EP	0553336	8/1993
EP	0745323	12/1996
EP	0806138	11/1997
EP	1149530	10/2001
GB	2329125	3/1999
GB	2384966	8/2003
JP	6165630	6/1994
WO	WO 02/102147	12/2002
WO	WO 03/059057	7/2003
WO	WO 2005/022992	3/2005
WO	WO 2005/072524	8/2005

* cited by examiner

Primary Examiner—Catherine R Oliver
(74) Attorney, Agent, or Firm—Hunton & Williams

(57) CLAIM

The ornamental design for a rodent trap, as shown and described.

DESCRIPTION

This application relates to and claims priority to U.S. Ser. No. 11/956,929, filed on Dec. 14, 2007.

FIG. 1 is a perspective view of a rodent trap showing the claimed design in accordance with a first embodiment.

FIG. 2 is a front elevation view of the rodent trap of FIG. 1 in accordance with a first embodiment.

FIG. 3 is a rear elevation view of the rodent trap of FIG. 1 in accordance with a first embodiment.

FIG. 4 is a left side elevation view of the rodent trap of FIG. 1 in accordance with a first embodiment.

FIG. 5 is a right side elevation view of the rodent trap of FIG. 1 in accordance with a first embodiment.

FIG. 6 is a top plan view of the rodent trap of FIG. 1 in accordance with a first embodiment.

FIG. 7 is a bottom plan view of the rodent trap of FIG. 1 in accordance with a first embodiment.

FIG. 8 is a perspective view of a rodent trap showing the claimed design in accordance with a second embodiment.

FIG. 9 is a front elevation view of the rodent trap of FIG. 8 in accordance with a second embodiment.

FIG. 10 is a rear elevation view of the rodent trap of FIG. 8 in accordance with a second embodiment.

FIG. 11 is a left side elevation view of the rodent trap of FIG. 8 in accordance with a second embodiment.

FIG. 12 is a right side elevation view of the rodent trap of FIG. 8 in accordance with a second embodiment.

FIG. 13 is a top plan view of the rodent trap of FIG. 8 in accordance with a second embodiment.

FIG. 14 is a bottom plan view of the rodent trap of FIG. 8 in accordance with a second embodiment.

FIG. 15 is a perspective view of a rodent trap showing the claimed design in accordance with a third embodiment.

FIG. 16 is a front elevation view of the rodent trap of FIG. 15 in accordance with a third embodiment.

FIG. 17 is a rear elevation view of the rodent trap of FIG. 15 in accordance with a third embodiment.

FIG. 18 is a left side elevation view of the rodent trap of FIG. 15 in accordance with a third embodiment.

FIG. 19 is a right side elevation view of the rodent trap of FIG. 15 in accordance with a third embodiment.

FIG. 20 is a top plan view of the rodent trap of FIG. 15 in accordance with a third embodiment.

FIG. 21 is a bottom plan view of the rodent trap of FIG. 15 in accordance with a third embodiment.

FIG. 22 is a perspective view of a rodent trap showing the claimed design in accordance with a fourth embodiment.

FIG. 23 is a front elevation view of the rodent trap of FIG. 22 in accordance with a fourth embodiment.

FIG. 24 is a rear elevation view of the rodent trap of FIG. 22 in accordance with a fourth embodiment.

FIG. 25 is a left side elevation view of the rodent trap of FIG. 22 in accordance with a fourth embodiment.

FIG. 26 is a right side elevation view of the rodent trap of FIG. 22 in accordance with a fourth embodiment.

FIG. 27 is a top plan view of the rodent trap of FIG. 22 in accordance with a fourth embodiment.

FIG. 28 is a bottom plan view of the rodent trap of FIG. 22 in accordance with a fourth embodiment.

FIG. 29 is a perspective view of a rodent trap showing the claimed design in accordance with a fifth embodiment.

FIG. 30 is a front elevation view of the rodent trap of FIG. 29 in accordance with a fifth embodiment.

FIG. 31 is a rear elevation view of the rodent trap of FIG. 29 in accordance with a fifth embodiment.

FIG. 32 is a left side elevation view of the rodent trap of FIG. 29 in accordance with a fifth embodiment.

FIG. 33 is a right side elevation view of the rodent trap of FIG. 29 in accordance with a fifth embodiment.

FIG. 34 is a top plan view of the rodent trap of FIG. 29 in accordance with a fifth embodiment.

FIG. 35 is a bottom plan view of the rodent trap of FIG. 29 in accordance with a fifth embodiment.

FIG. 36 is a perspective view of a rodent trap showing the claimed design in accordance with a sixth embodiment.

FIG. 37 is a front elevation view of the rodent trap of FIG. 36 in accordance with a sixth embodiment.

FIG. 38 is a rear elevation view of the rodent trap of FIG. 36 in accordance with a sixth embodiment.

FIG. 39 is a left side elevation view of the rodent trap of FIG. 36 in accordance with a sixth embodiment.

FIG. 40 is a right side elevation view of the rodent trap of FIG. 36 in accordance with a sixth embodiment.

FIG. 41 is a top plan view of the rodent trap of FIG. 36 in accordance with a sixth embodiment.

FIG. 42 is a bottom plan view of the rodent trap of FIG. 36 in accordance with a sixth embodiment.

FIG. 43 is a perspective view of a rodent trap showing the claimed design in accordance with a seventh embodiment.

FIG. 44 is a front elevation view of the rodent trap of FIG. 43 in accordance with a seventh embodiment.

FIG. 45 is a rear elevation view of the rodent trap of FIG. 43 in accordance with a seventh embodiment.

FIG. 46 is a left side elevation view of the rodent trap of FIG. 43 in accordance with a seventh embodiment.

FIG. 47 is a right side elevation view of the rodent trap of FIG. 43 in accordance with a seventh embodiment.

FIG. 48 is a top plan view of the rodent trap of FIG. 43 in accordance with a seventh embodiment.

FIG. 49 is a bottom plan view of the rodent trap of FIG. 43 in accordance with a seventh embodiment.

FIG. 50 is a perspective view of a rodent trap showing the claimed design in accordance with an eighth embodiment.

FIG. 51 is a front elevation view of the rodent trap of FIG. 50 in accordance with an eighth embodiment.

FIG. 52 is a rear elevation view of the rodent trap of FIG. 50 in accordance with an eighth embodiment.

FIG. 53 is a left side elevation view of the rodent trap of FIG. 50 in accordance with an eighth embodiment.

FIG. 54 is a right side elevation view of the rodent trap of FIG. 50 in accordance with an eighth embodiment.

FIG. 55 is a top plan view of the rodent trap of FIG. 50 in accordance with an eighth embodiment; and,

FIG. 56 is a bottom plan view of the rodent trap of FIG. 50 in accordance with an eighth embodiment.

1 Claim, 40 Drawing Sheets

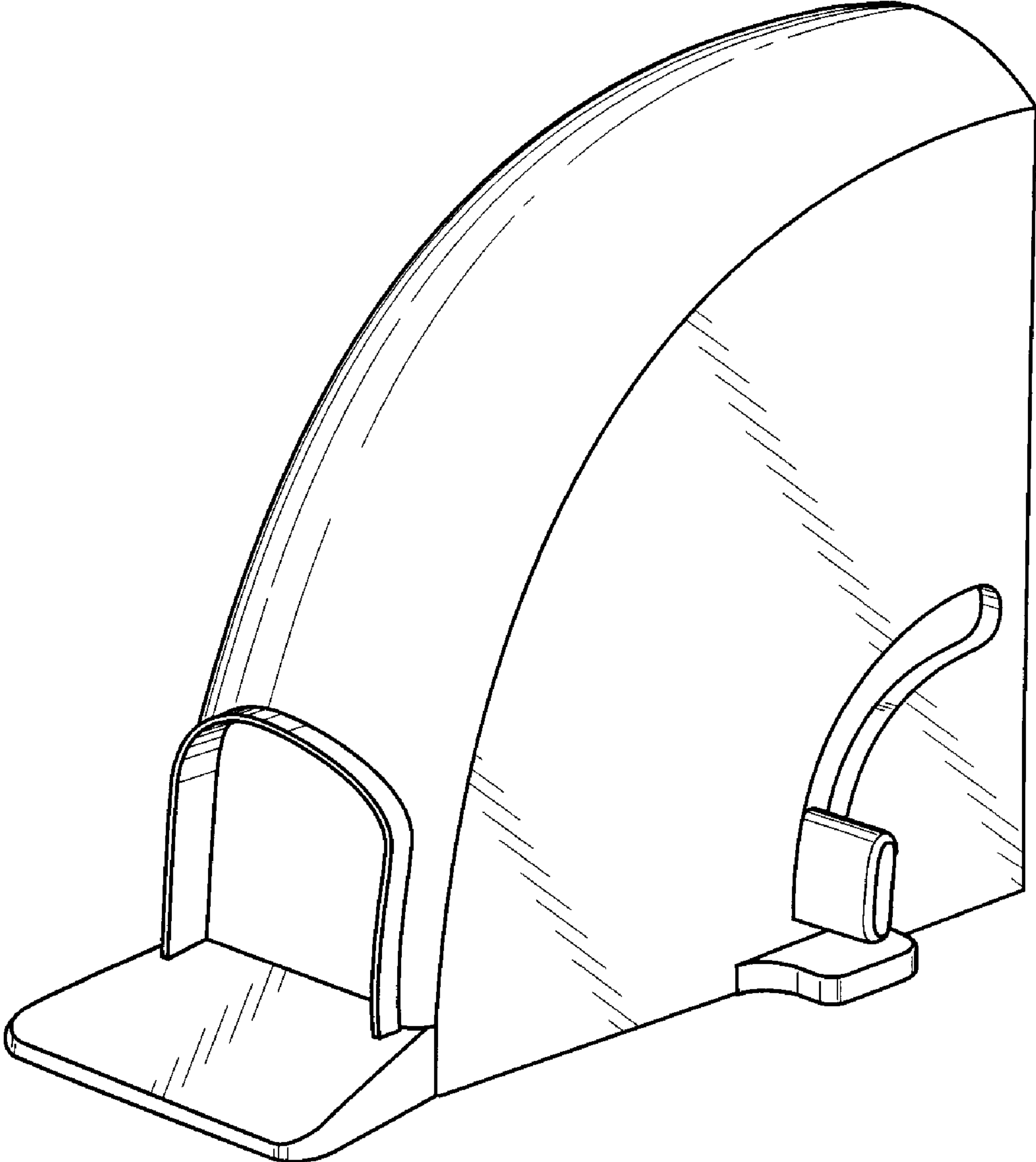

Fig. 1

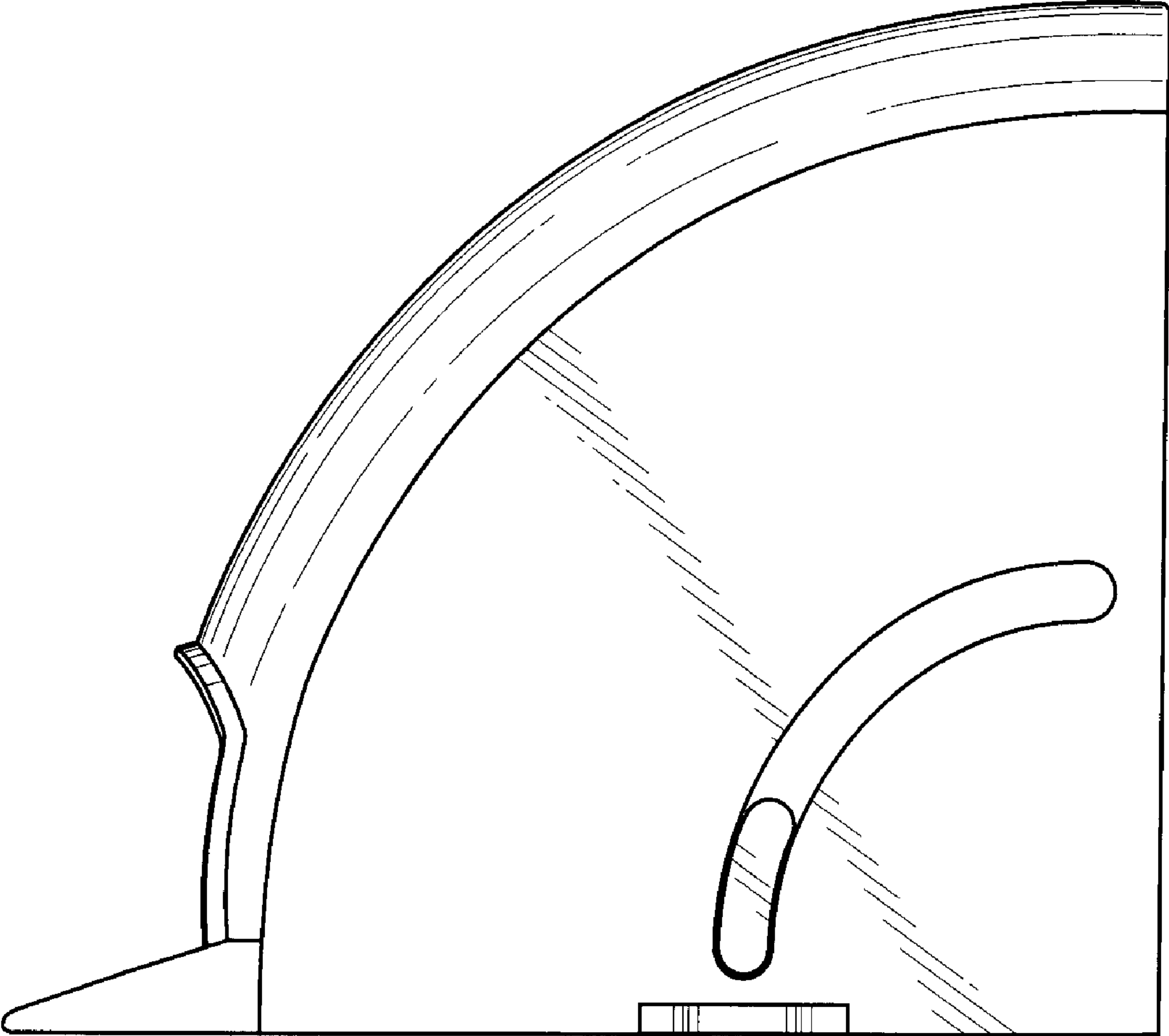

Fig. 2

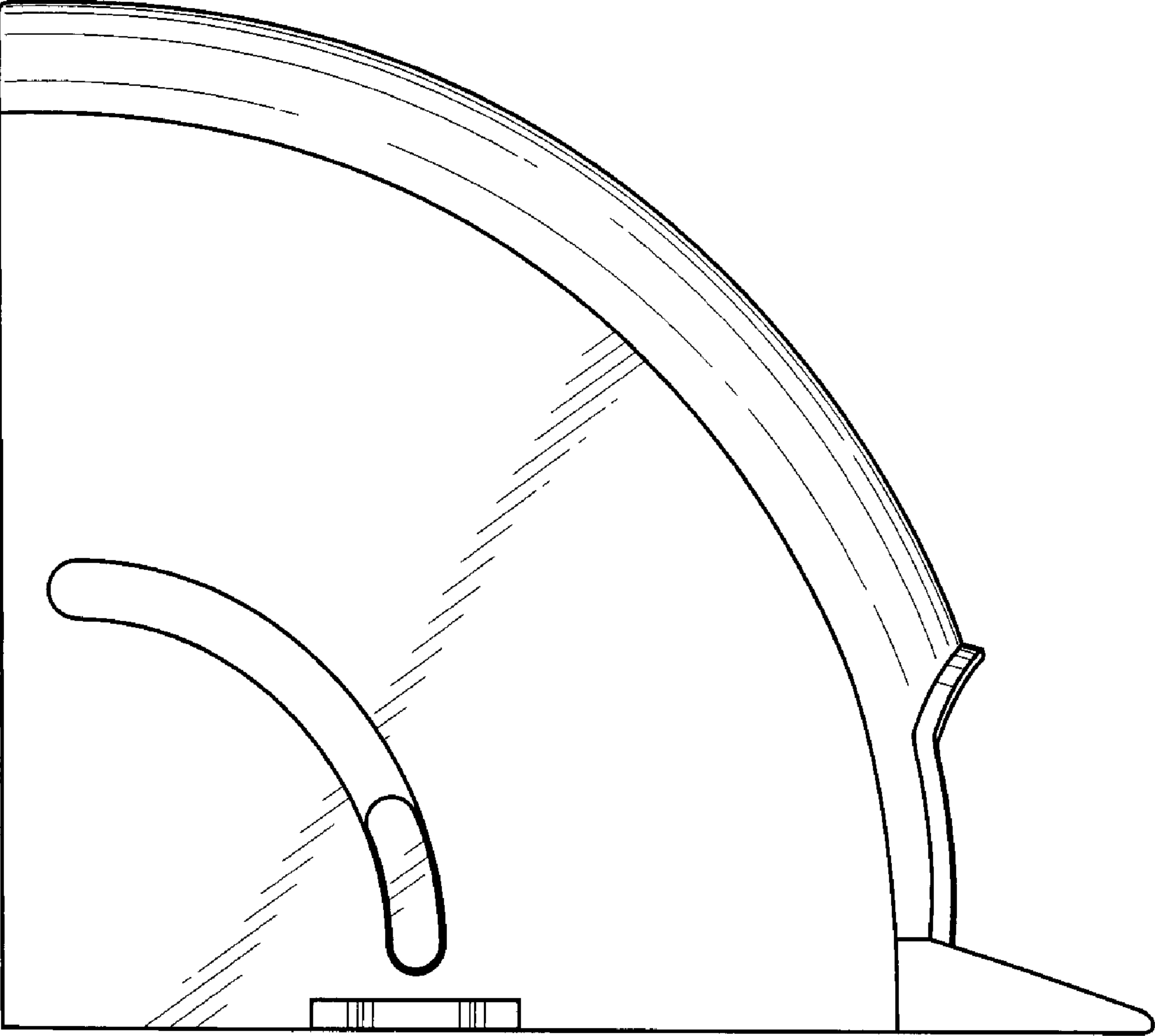

Fig. 3

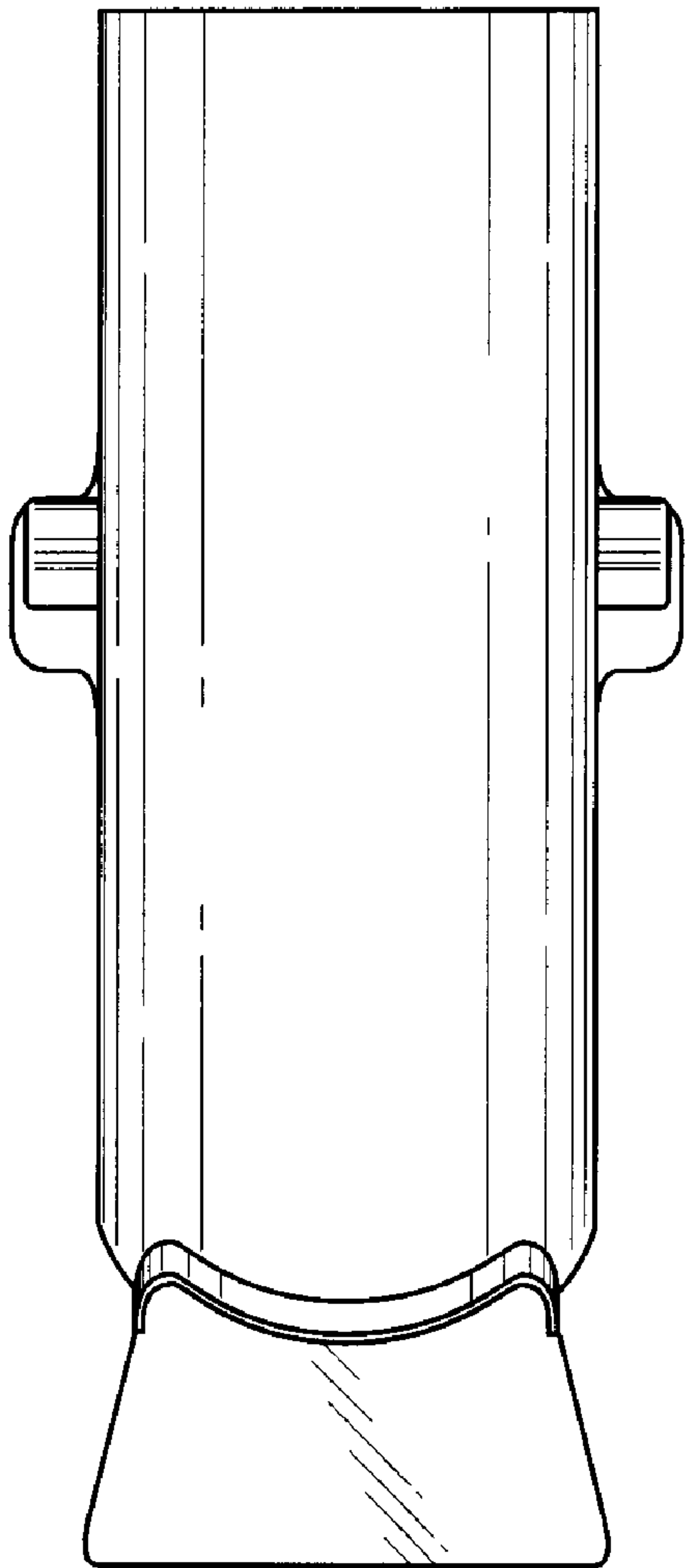

Fig. 4

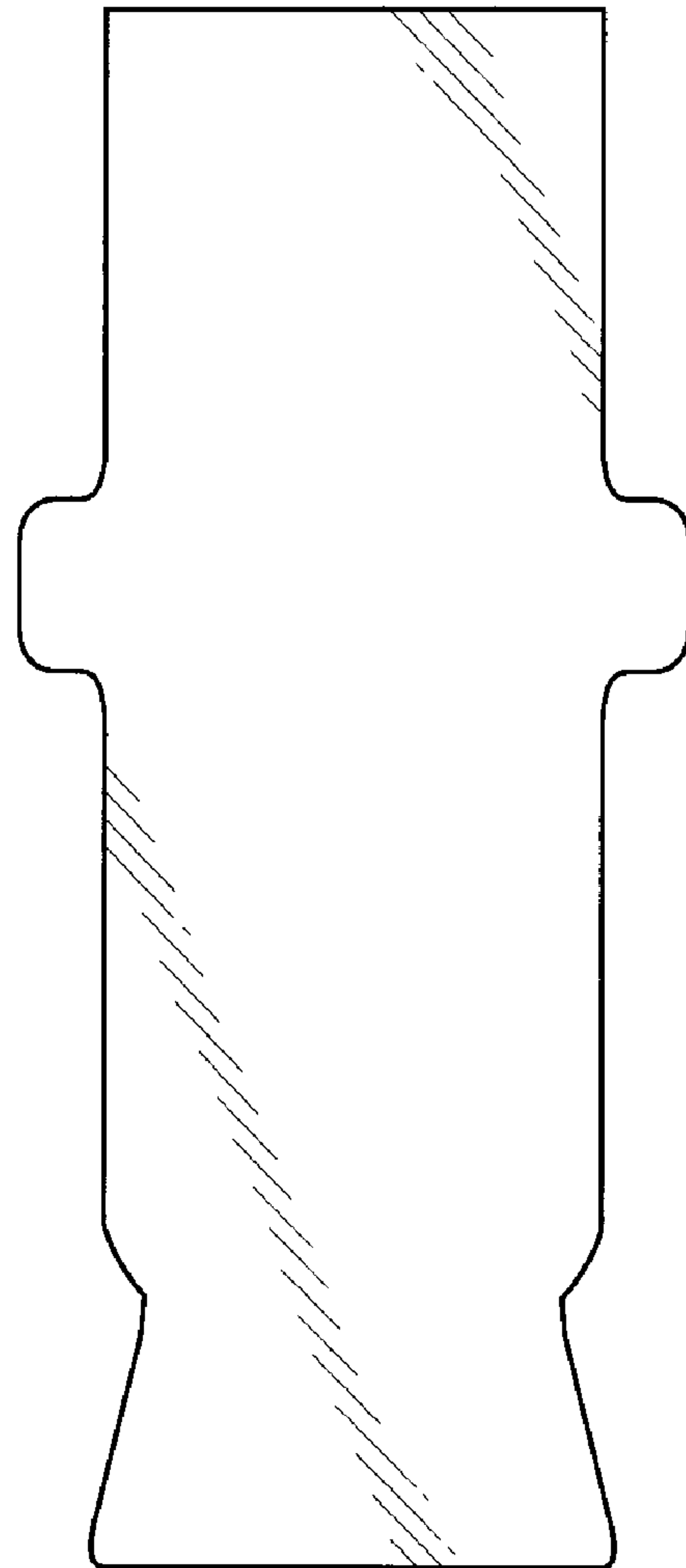

Fig. 5

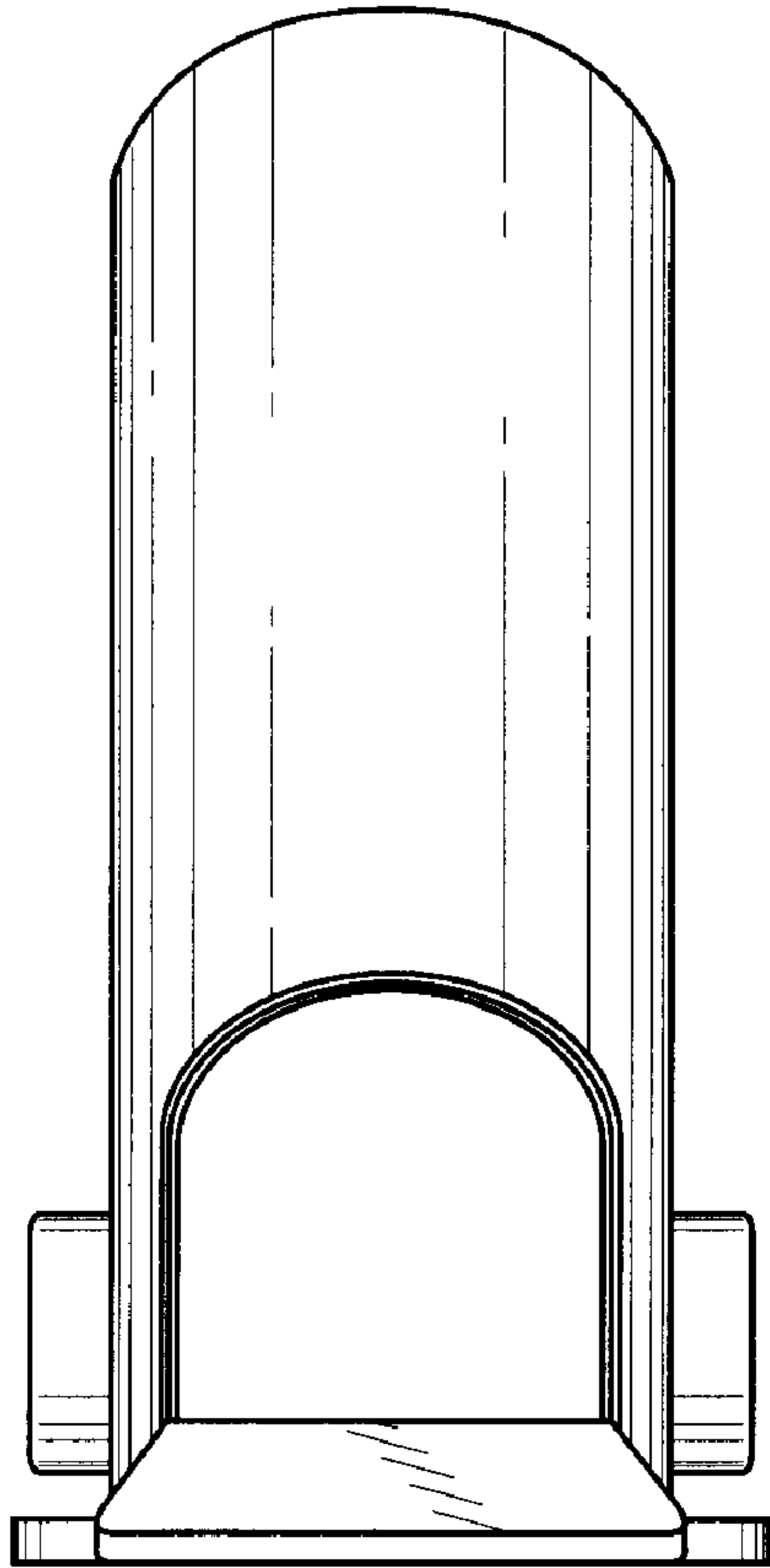

Fig. 6

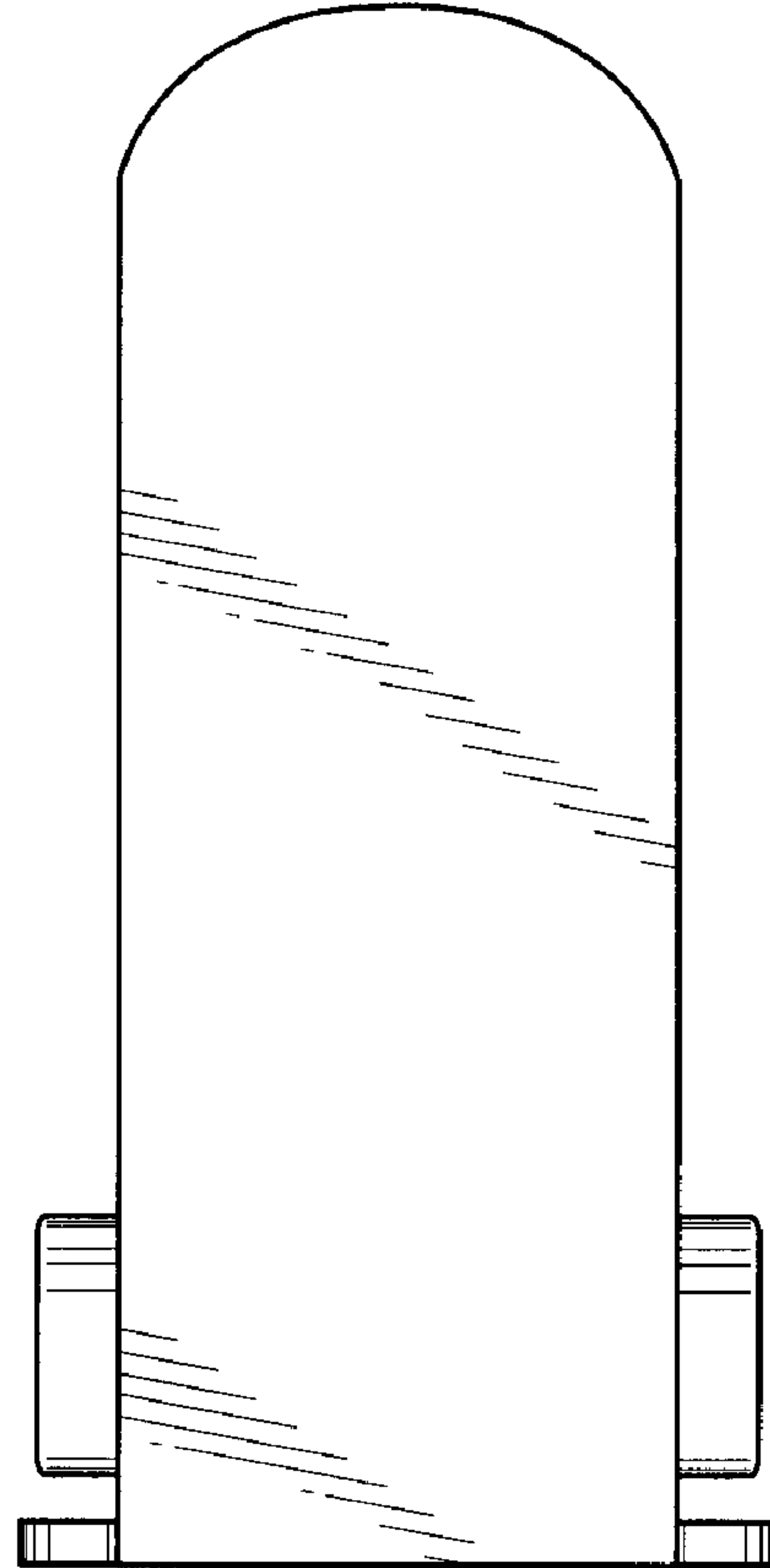

Fig. 7

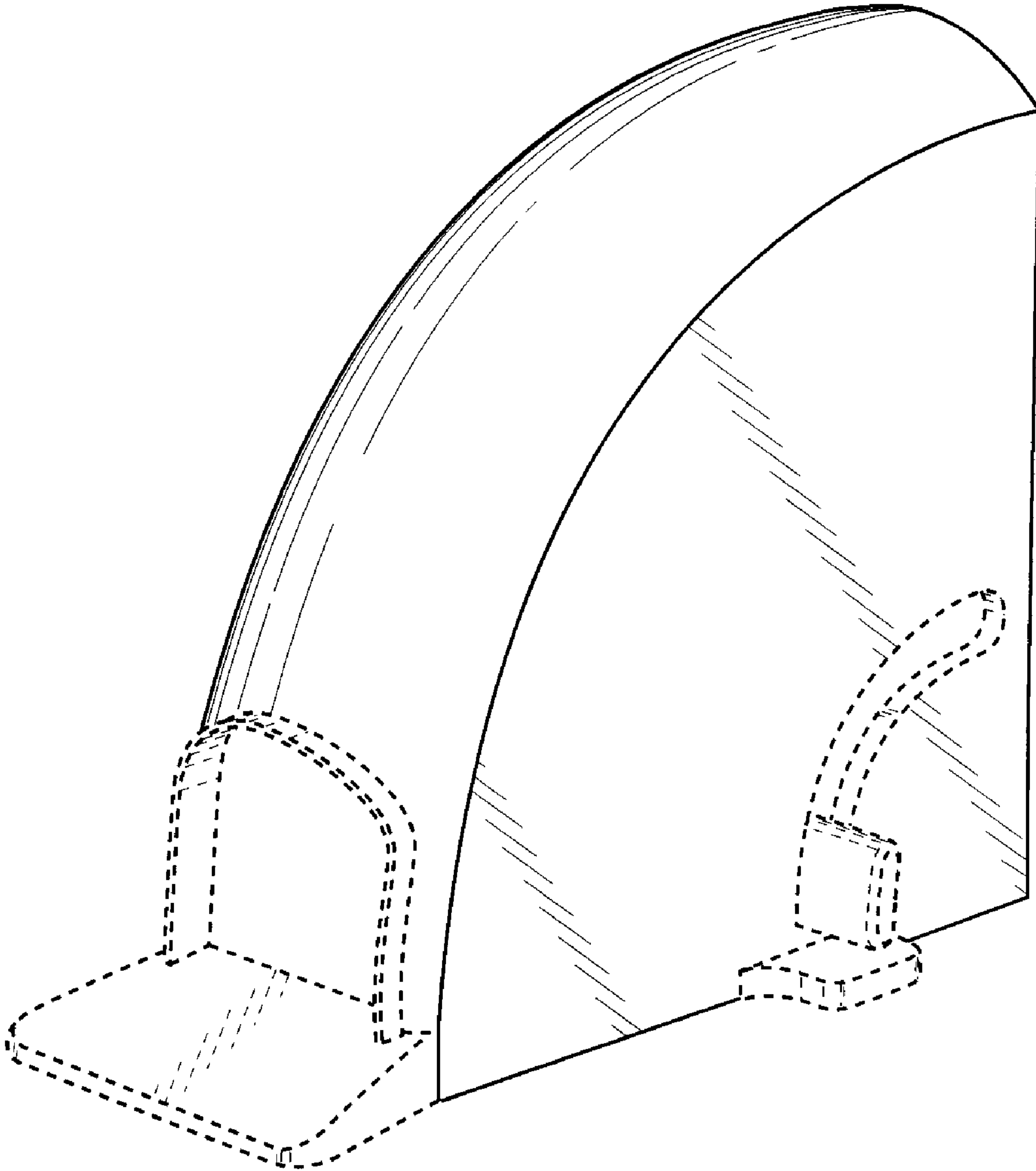

Fig. 8

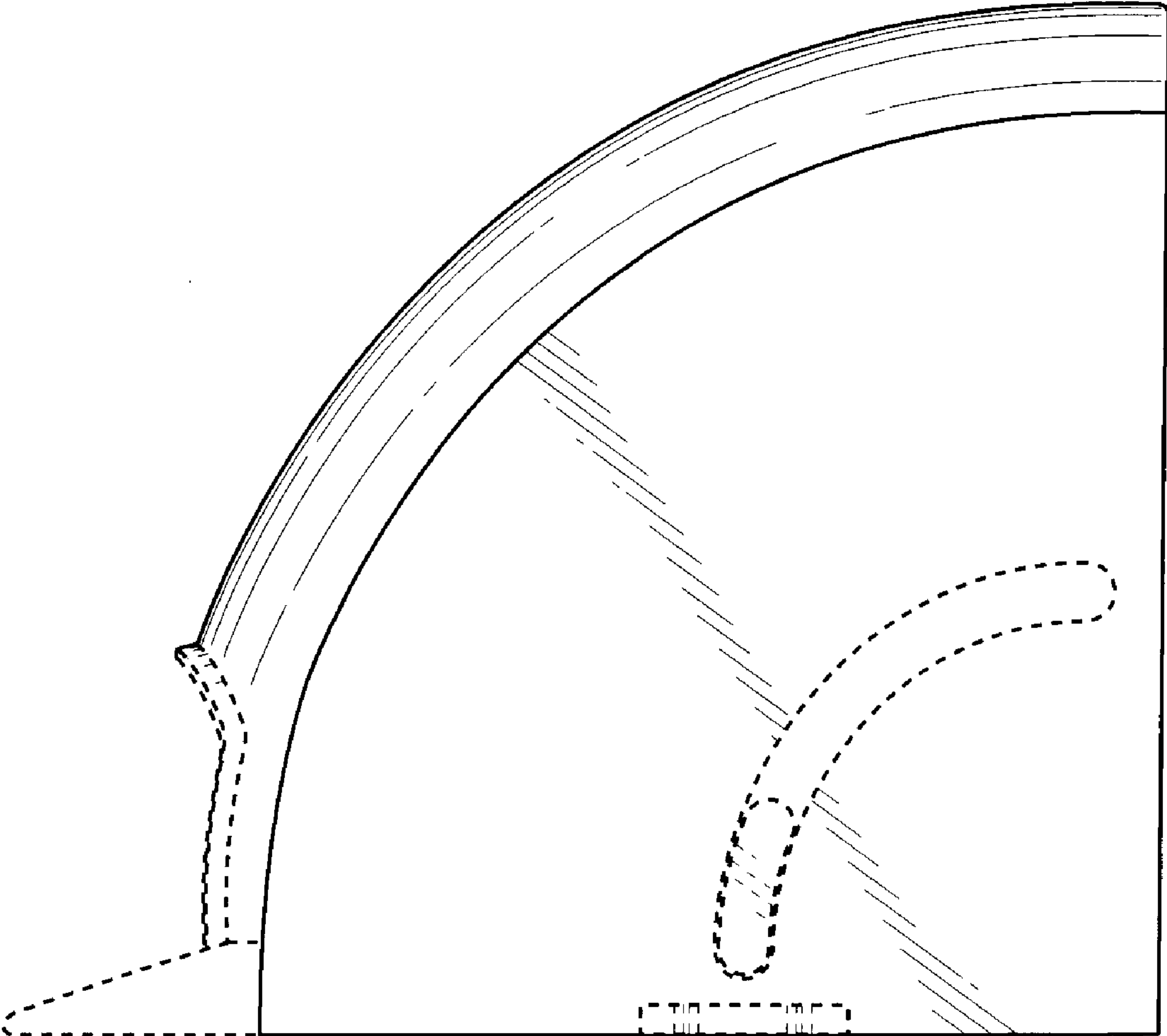

Fig. 9

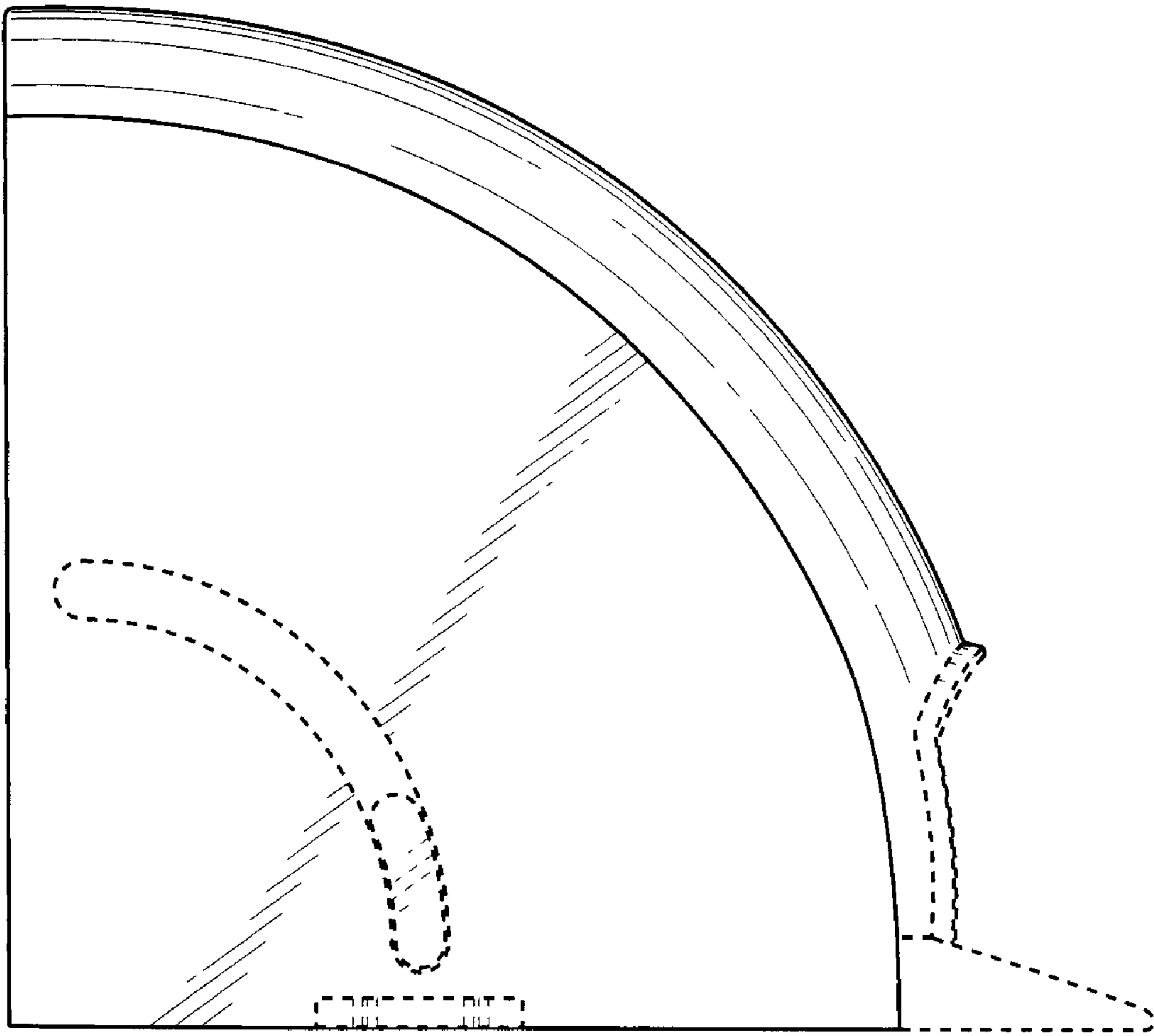

Fig. 10

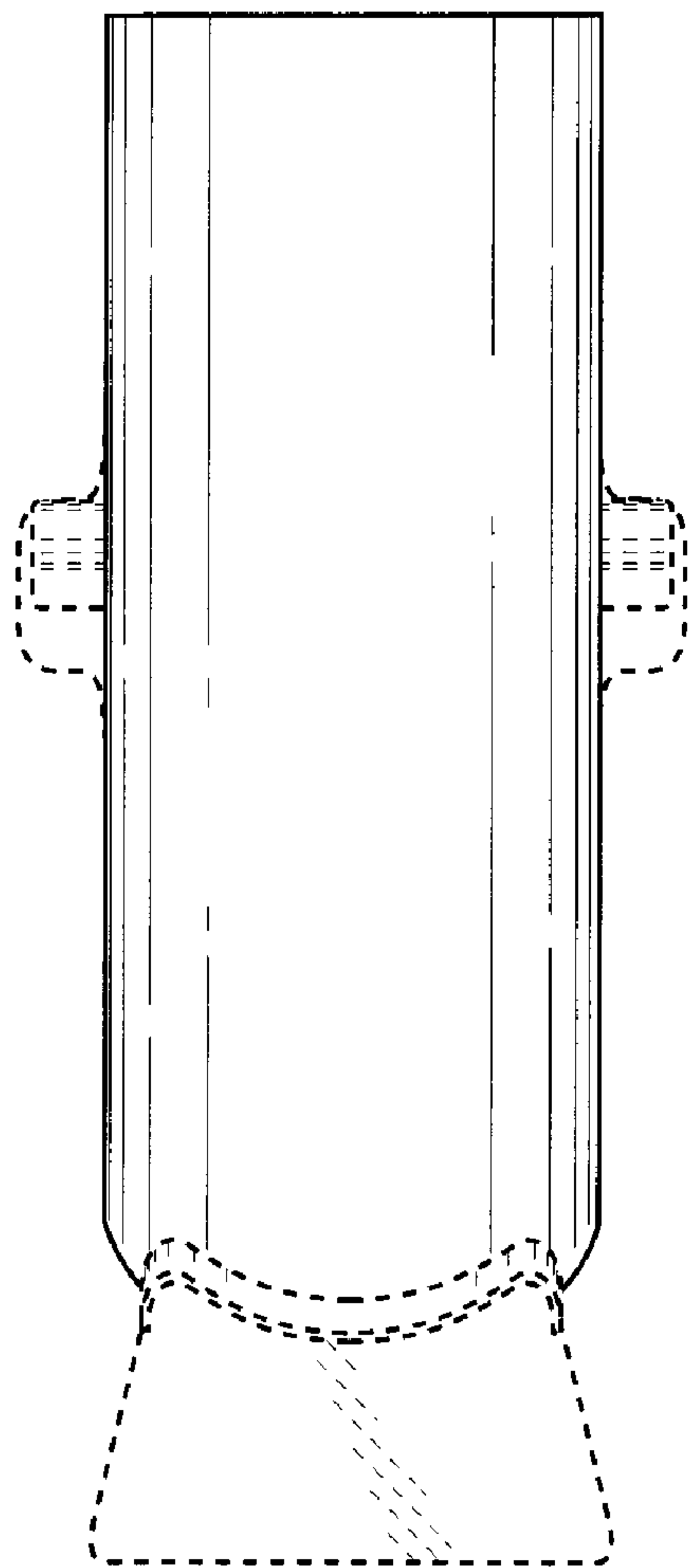

Fig. 11

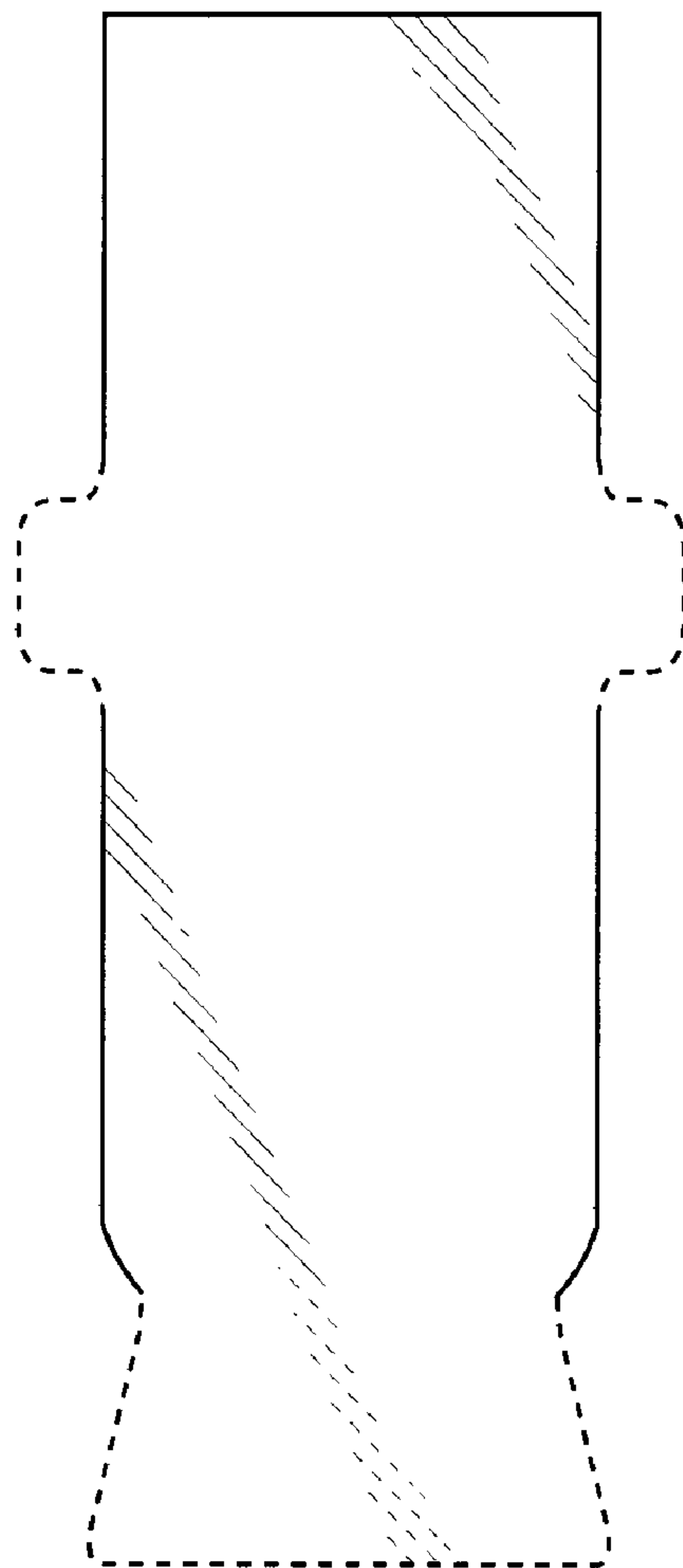

Fig. 12

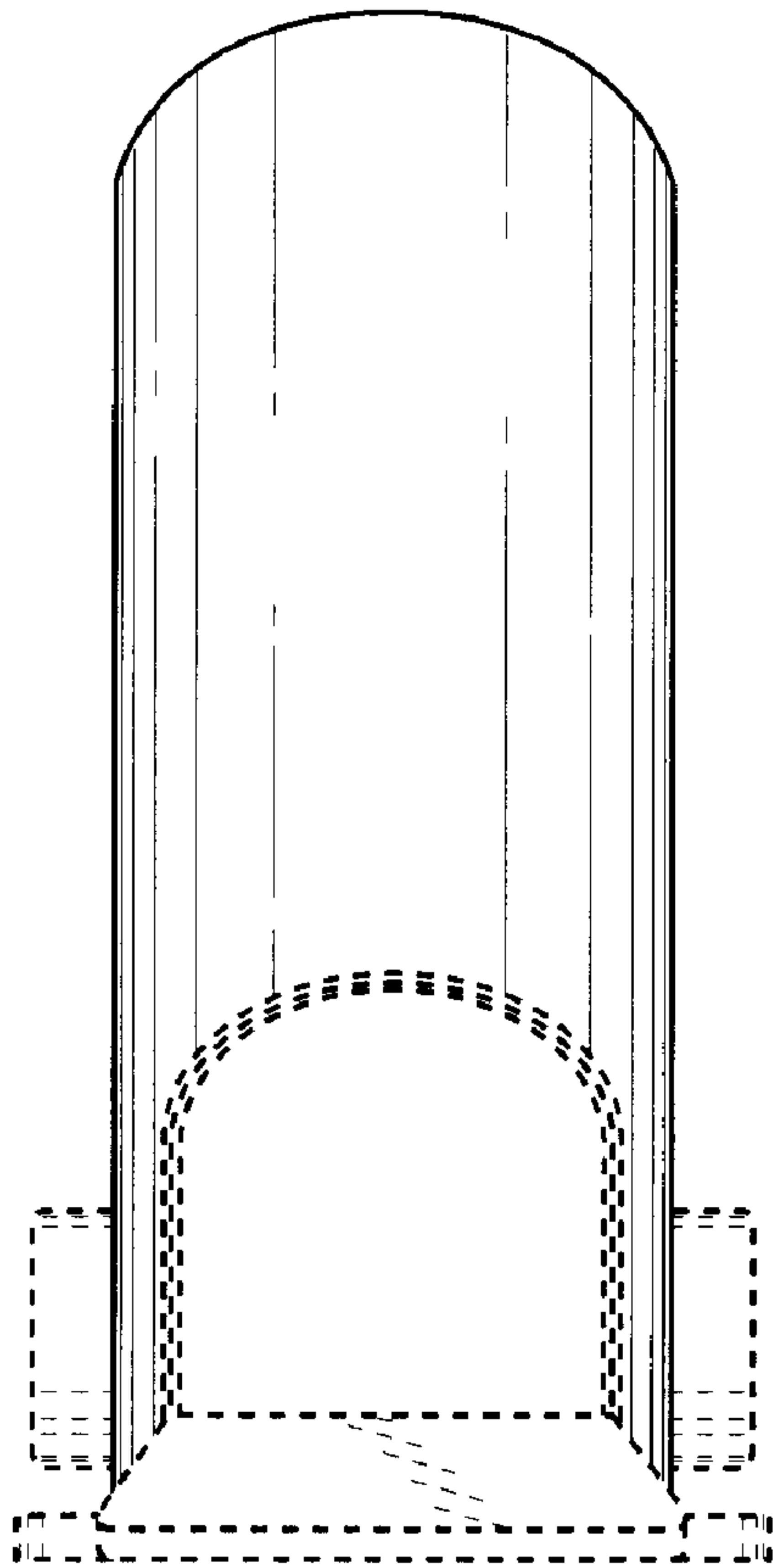

Fig. 13

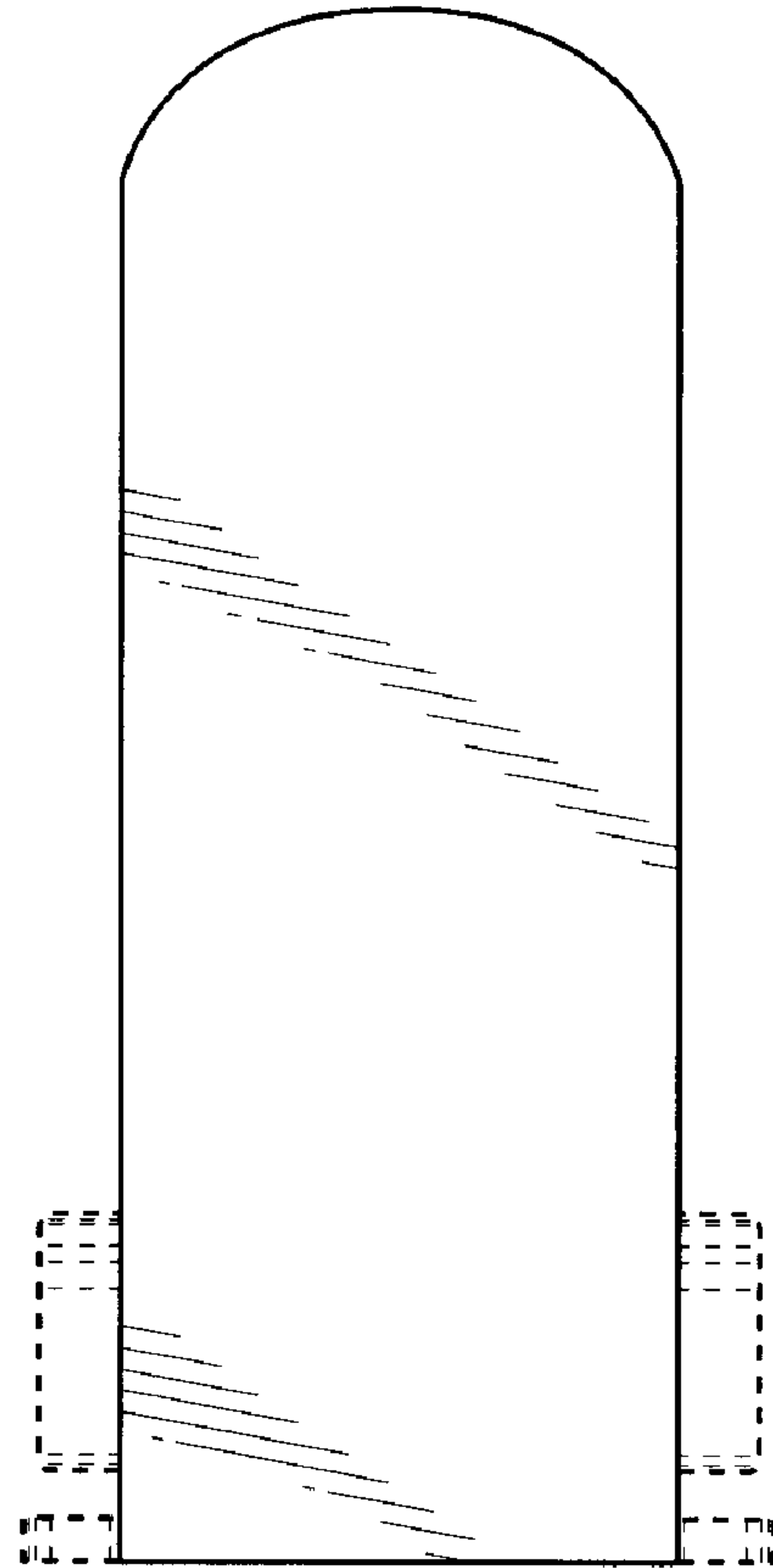

Fig. 14

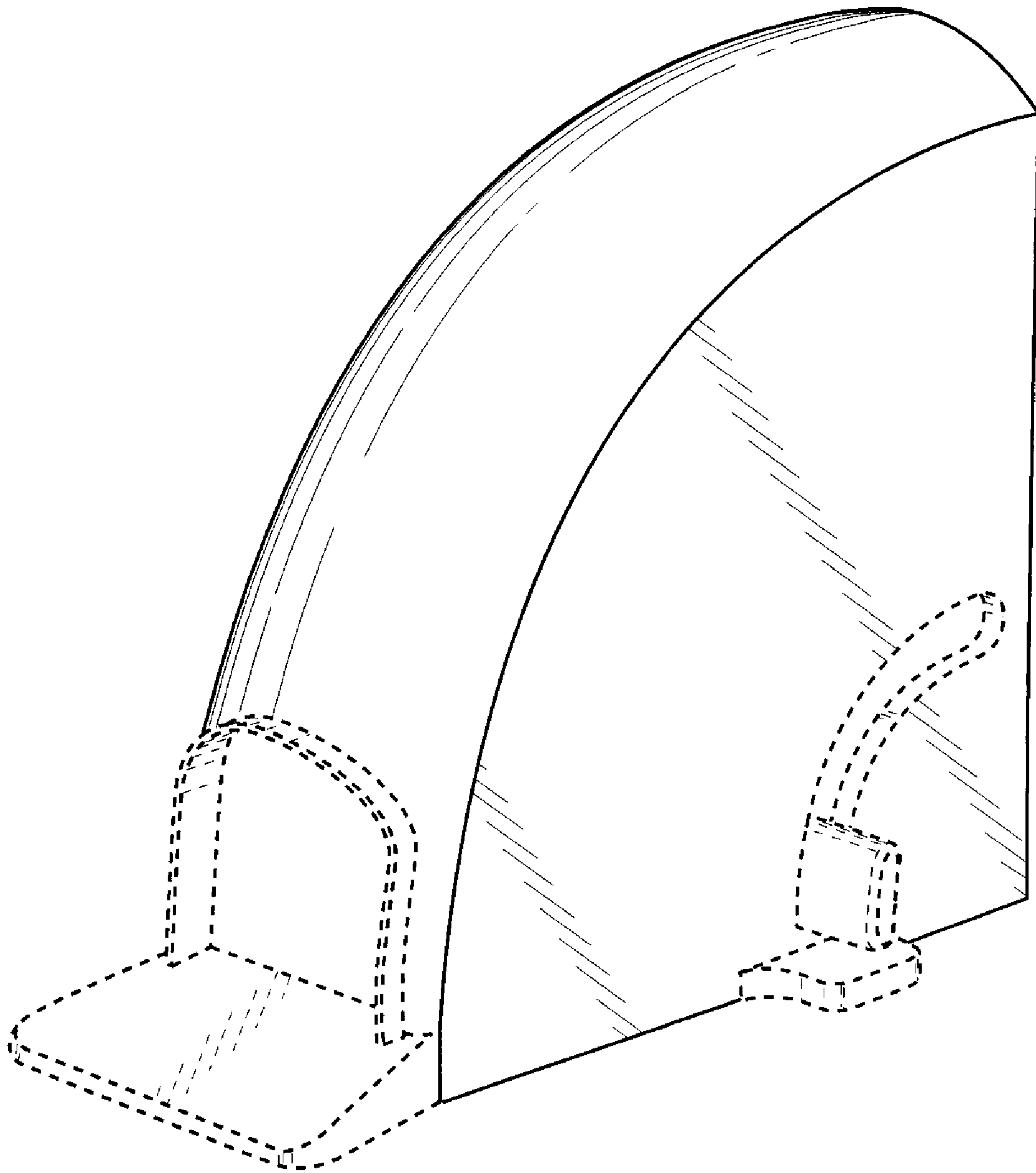

Fig. 15

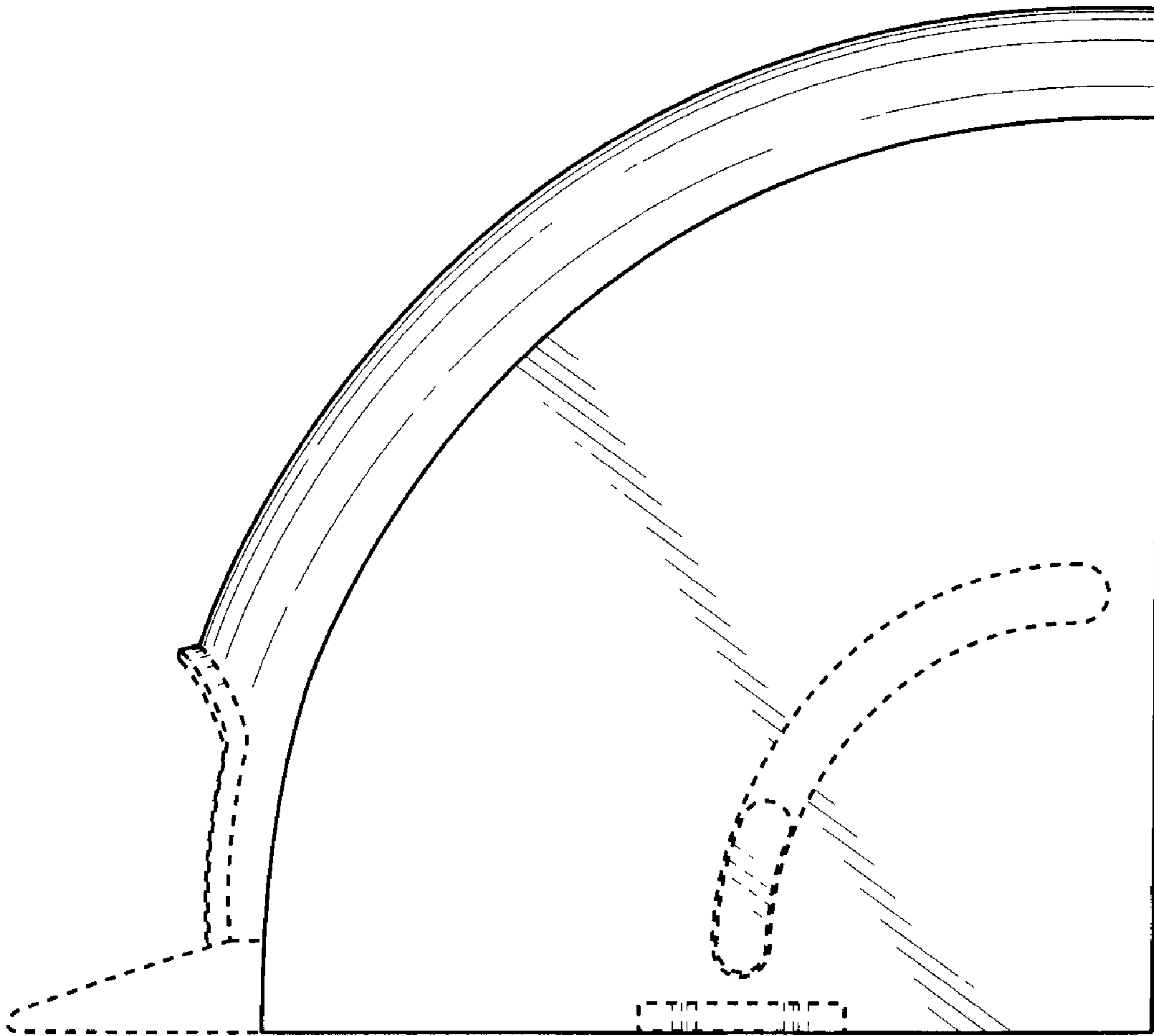

Fig. 16

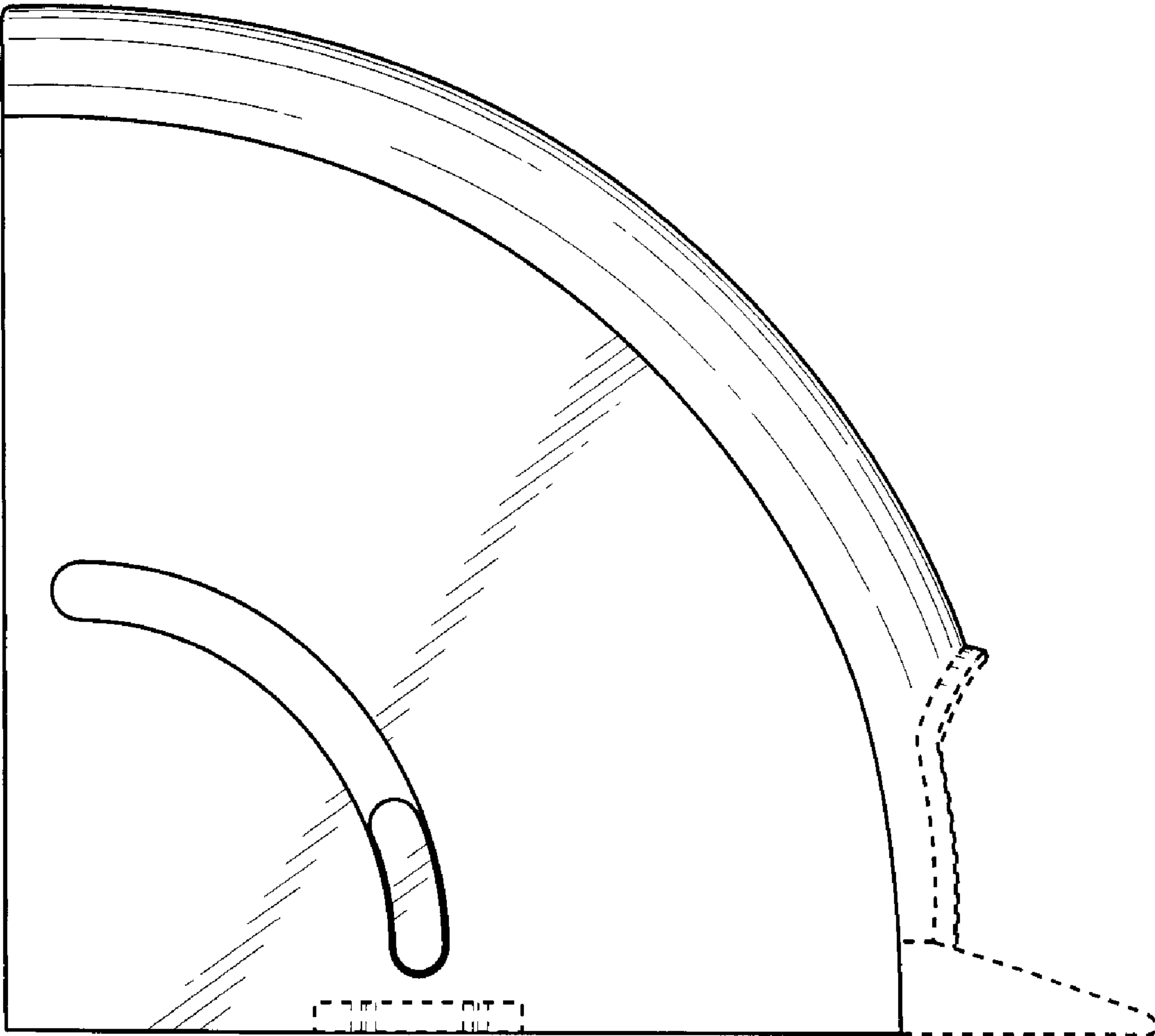

Fig. 17

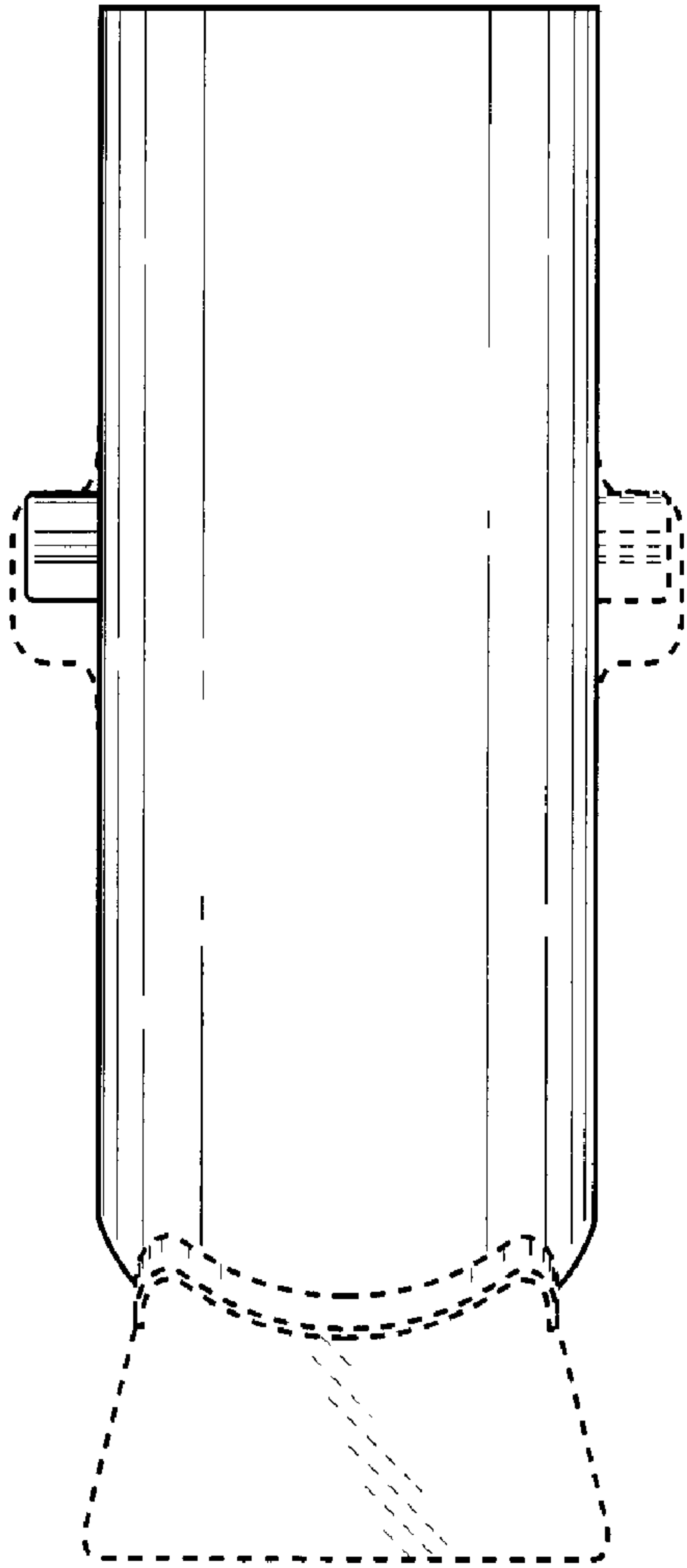

Fig. 18

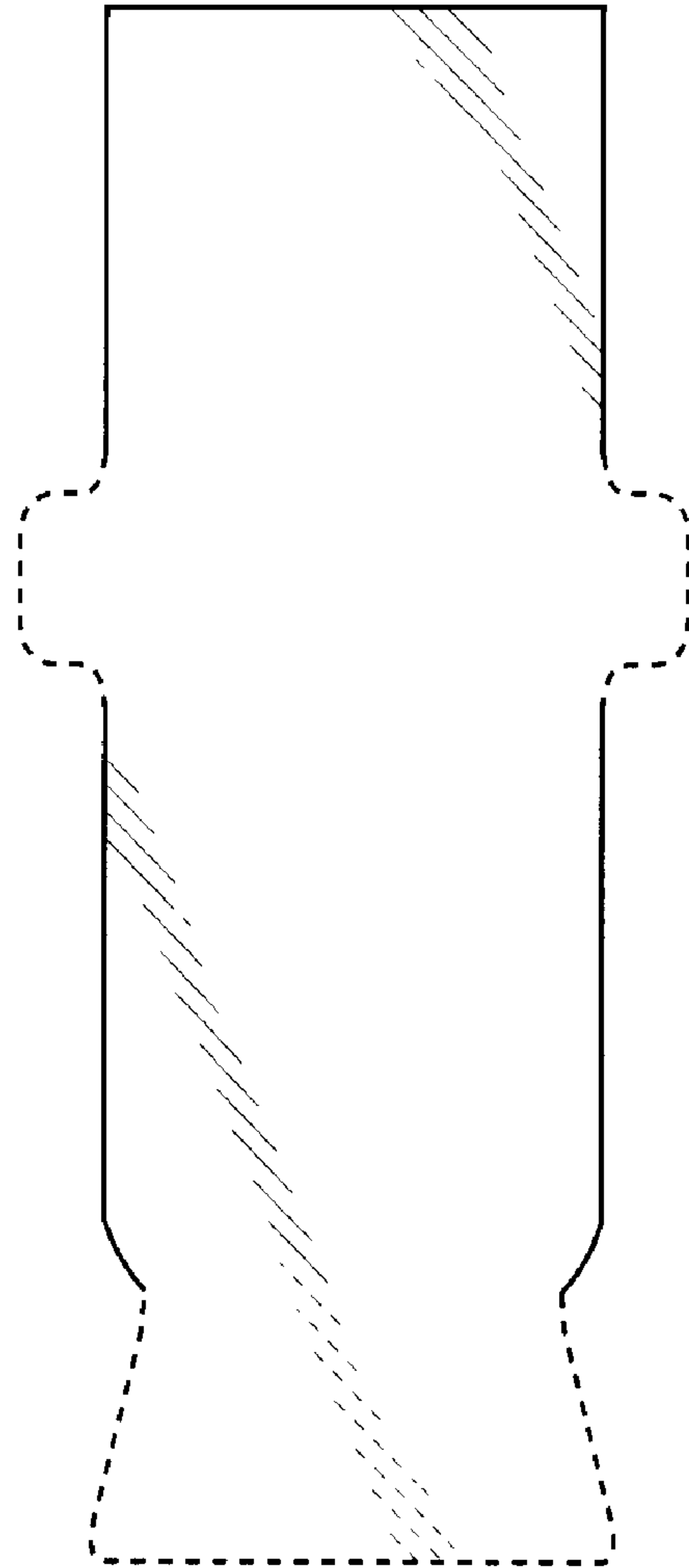

Fig. 19

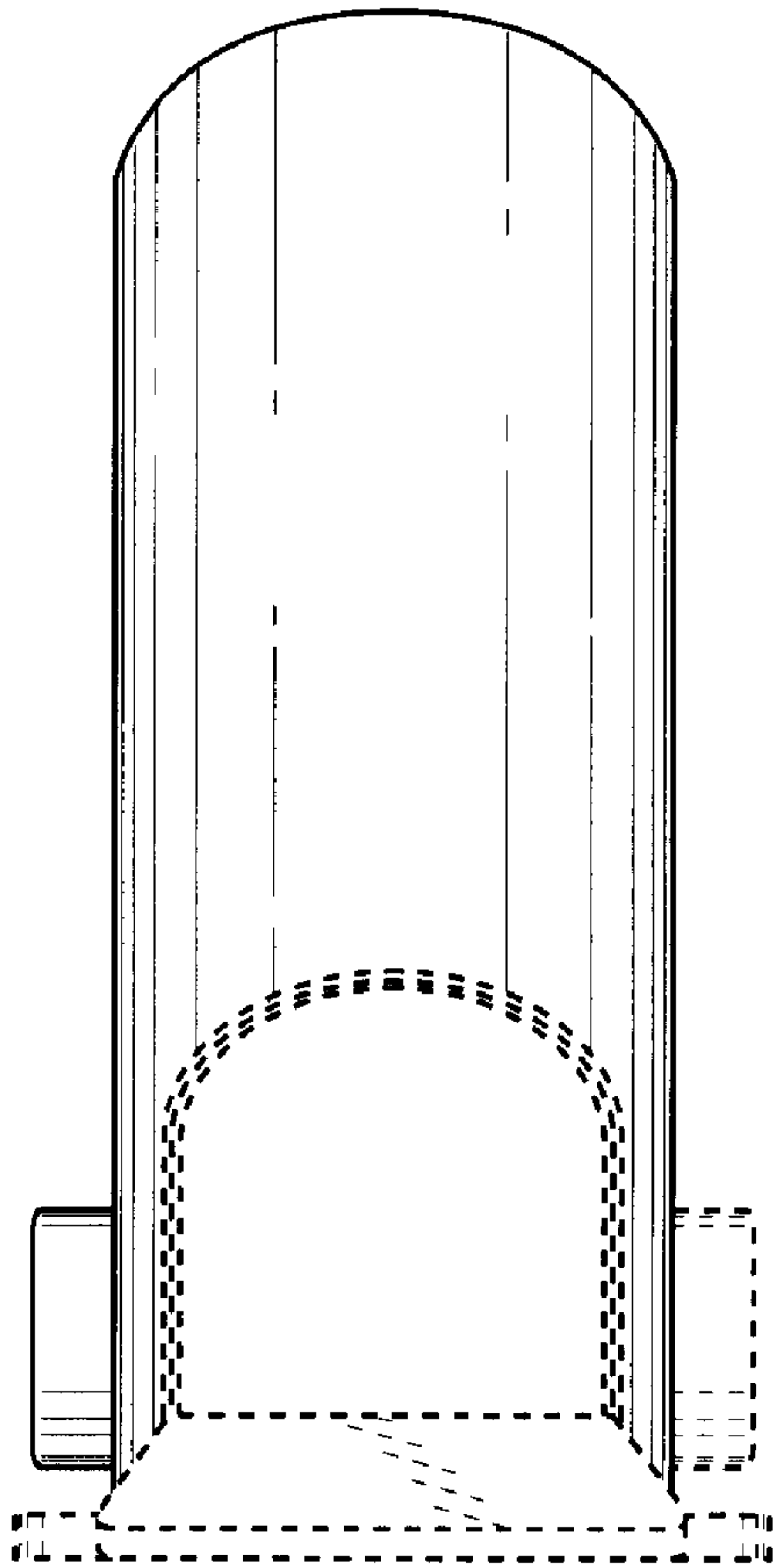

Fig. 20

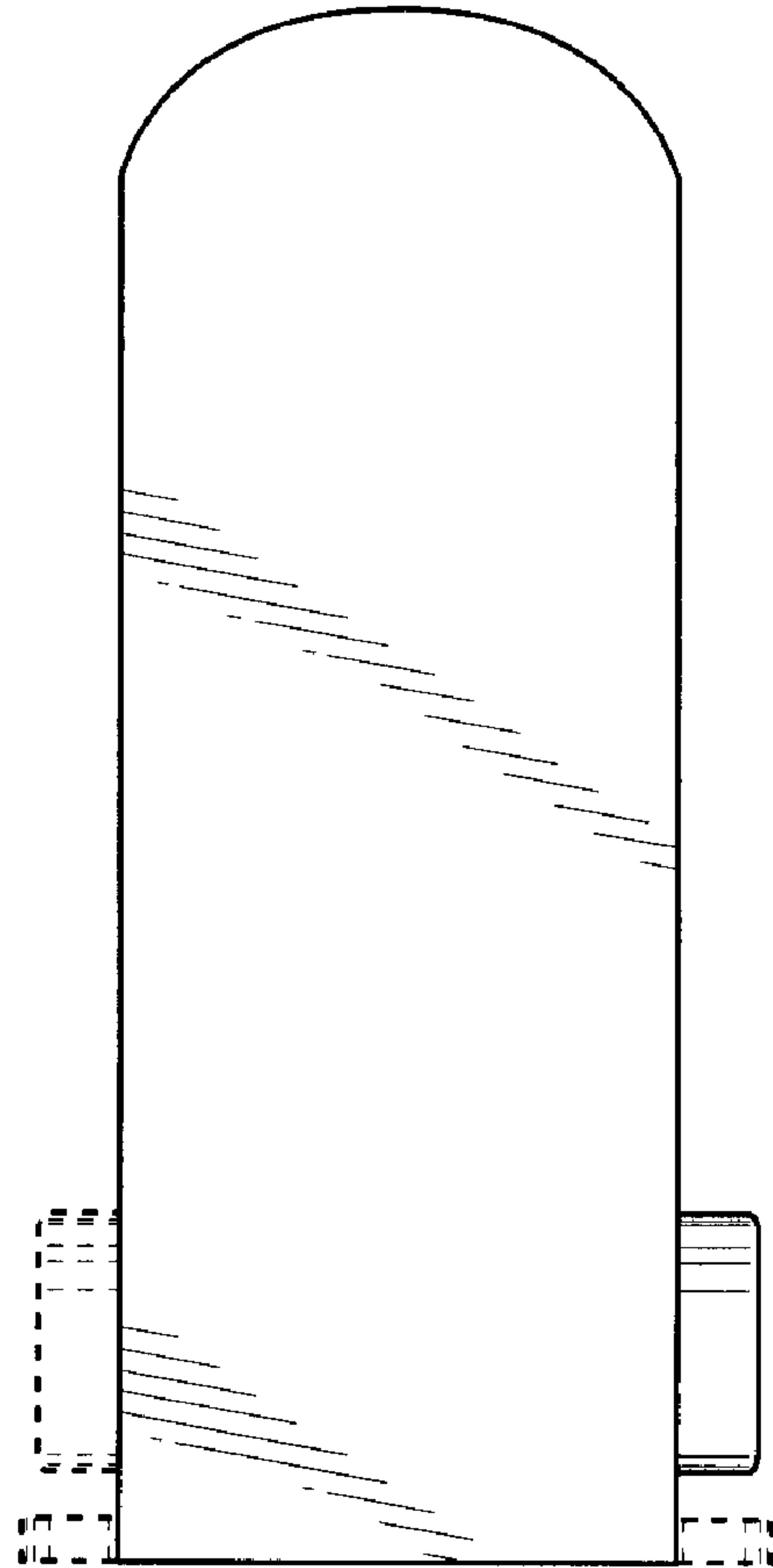

Fig. 21

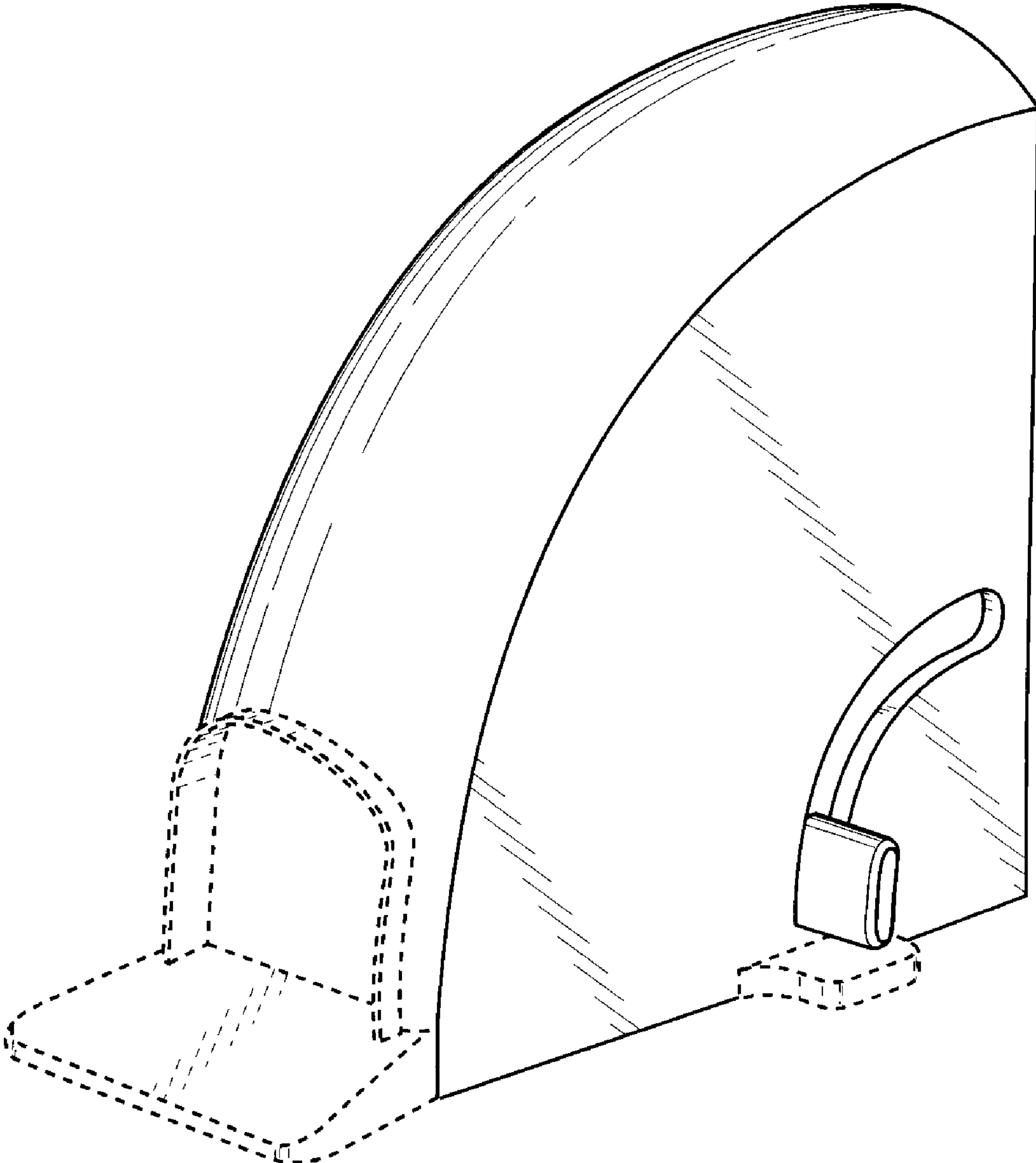

Fig. 22

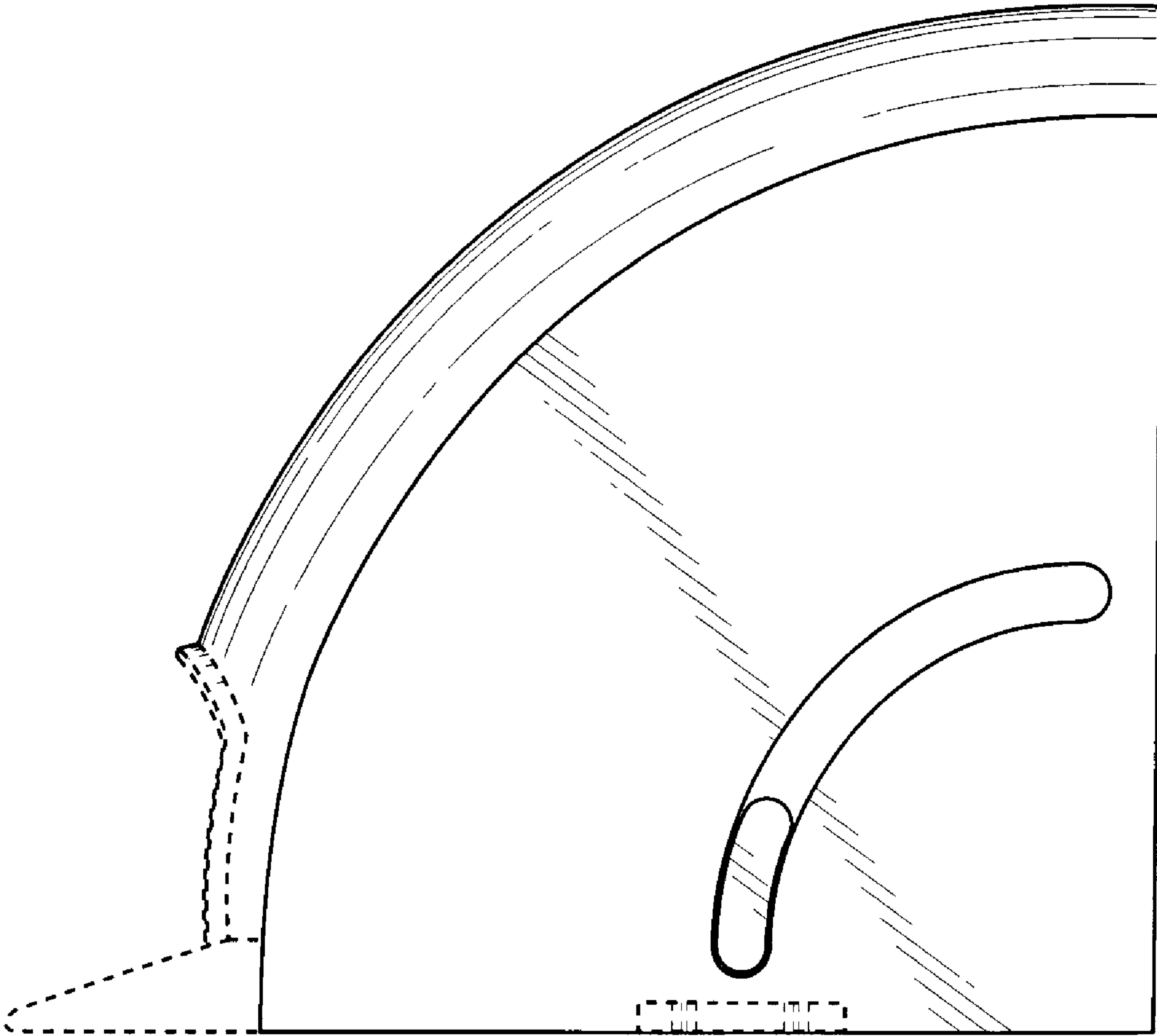

Fig. 23

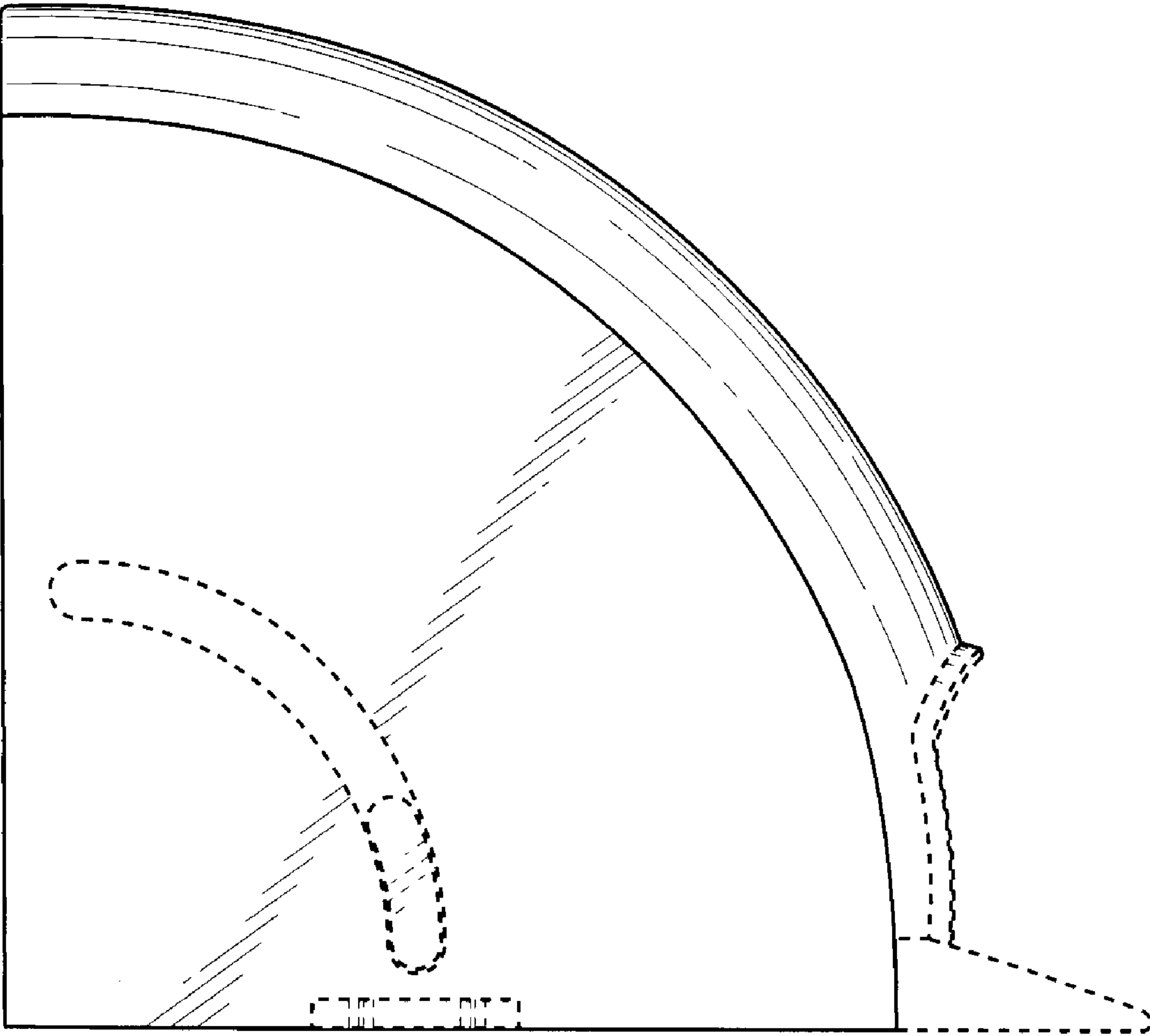

Fig. 24

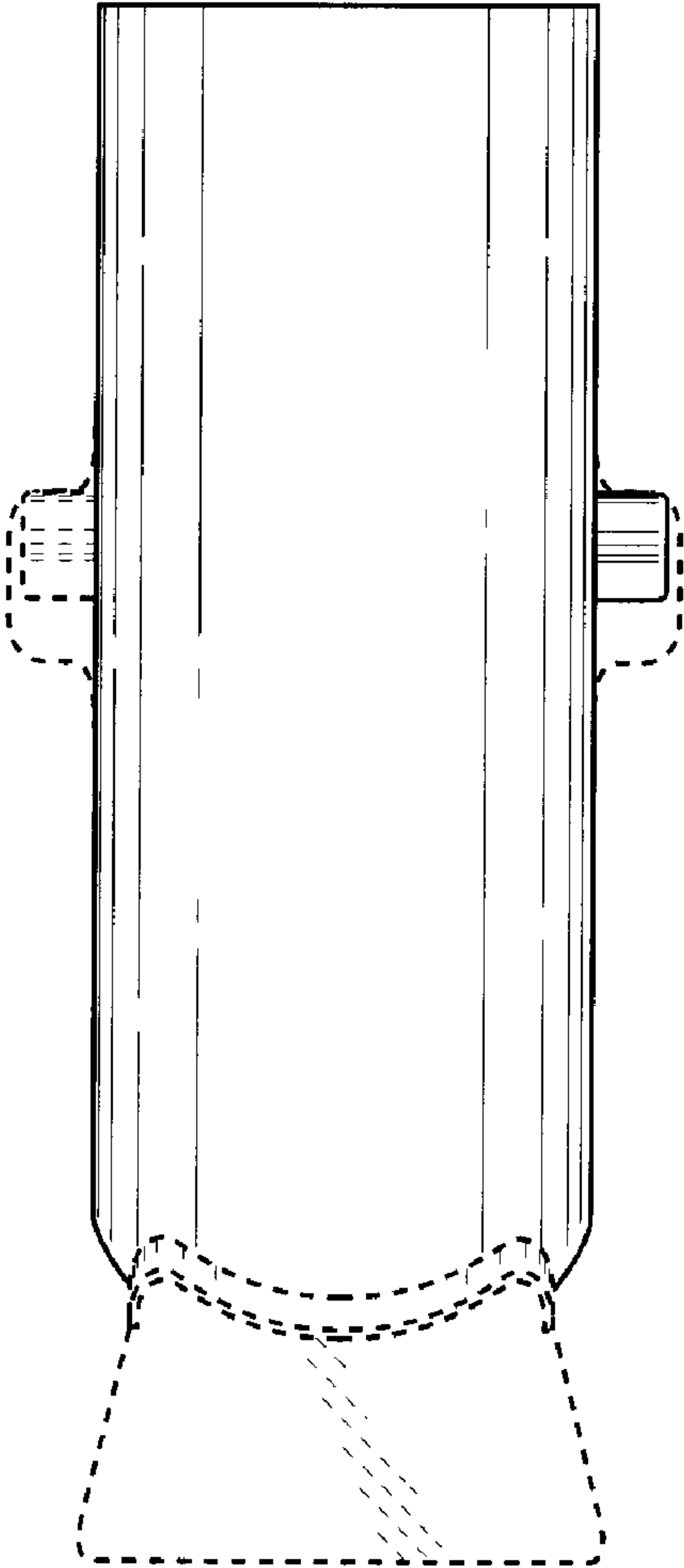

Fig. 25

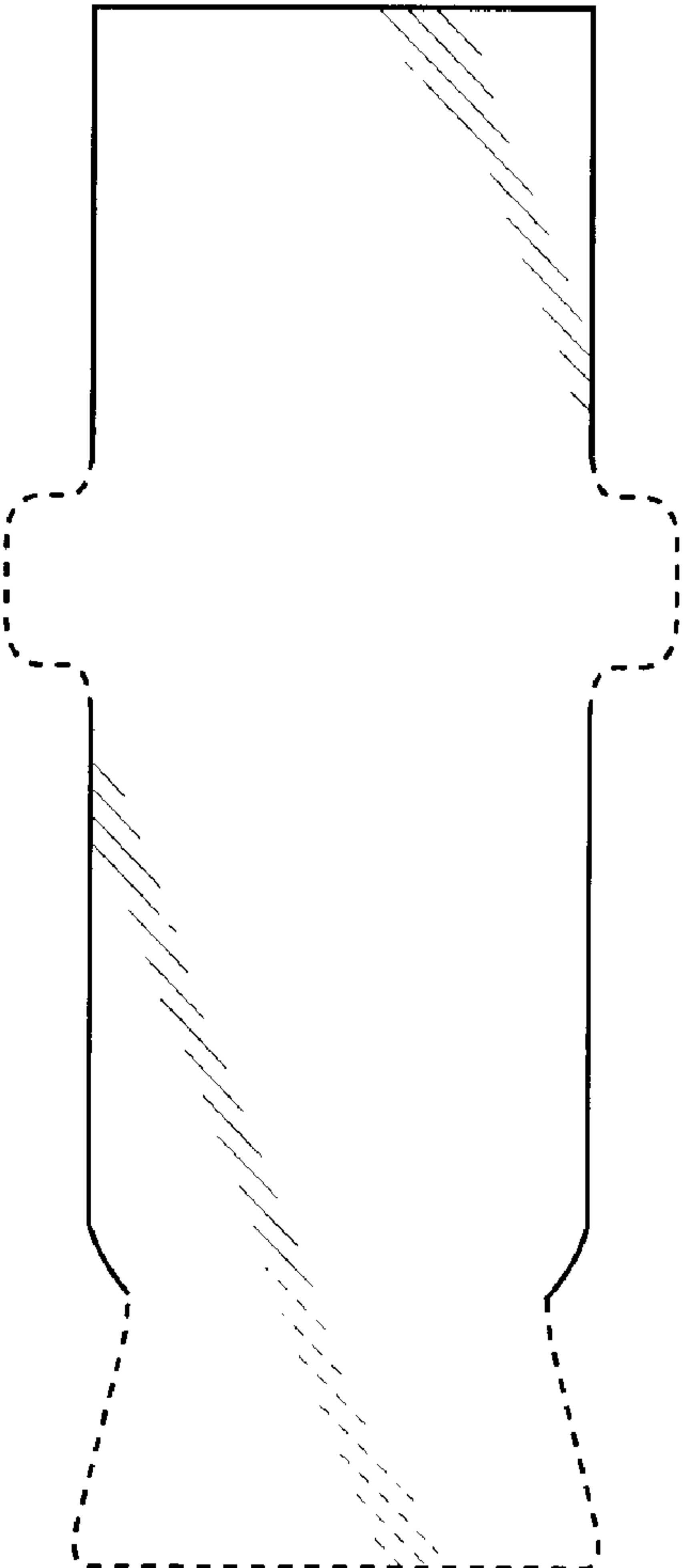

Fig. 26

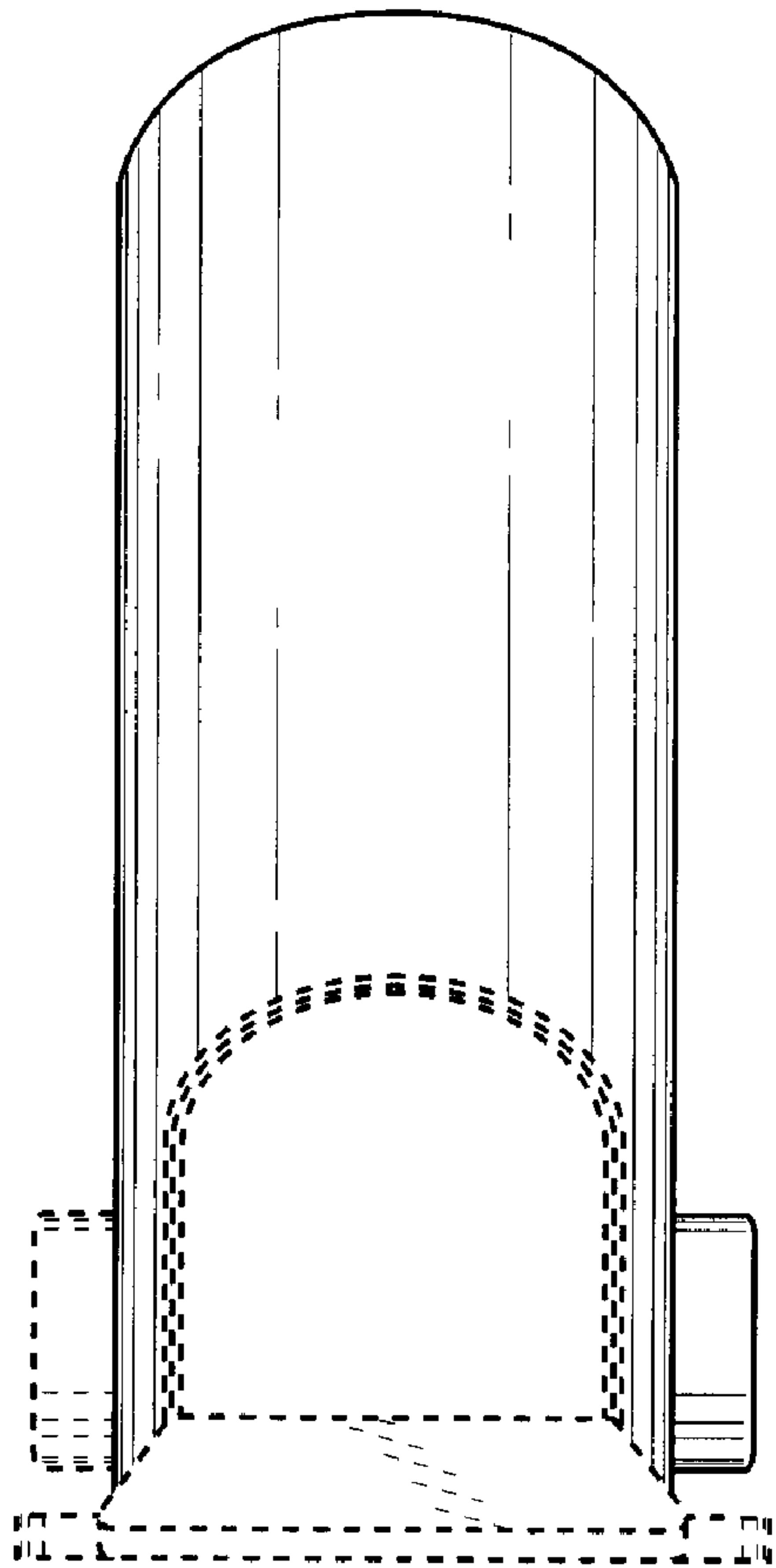

Fig. 27

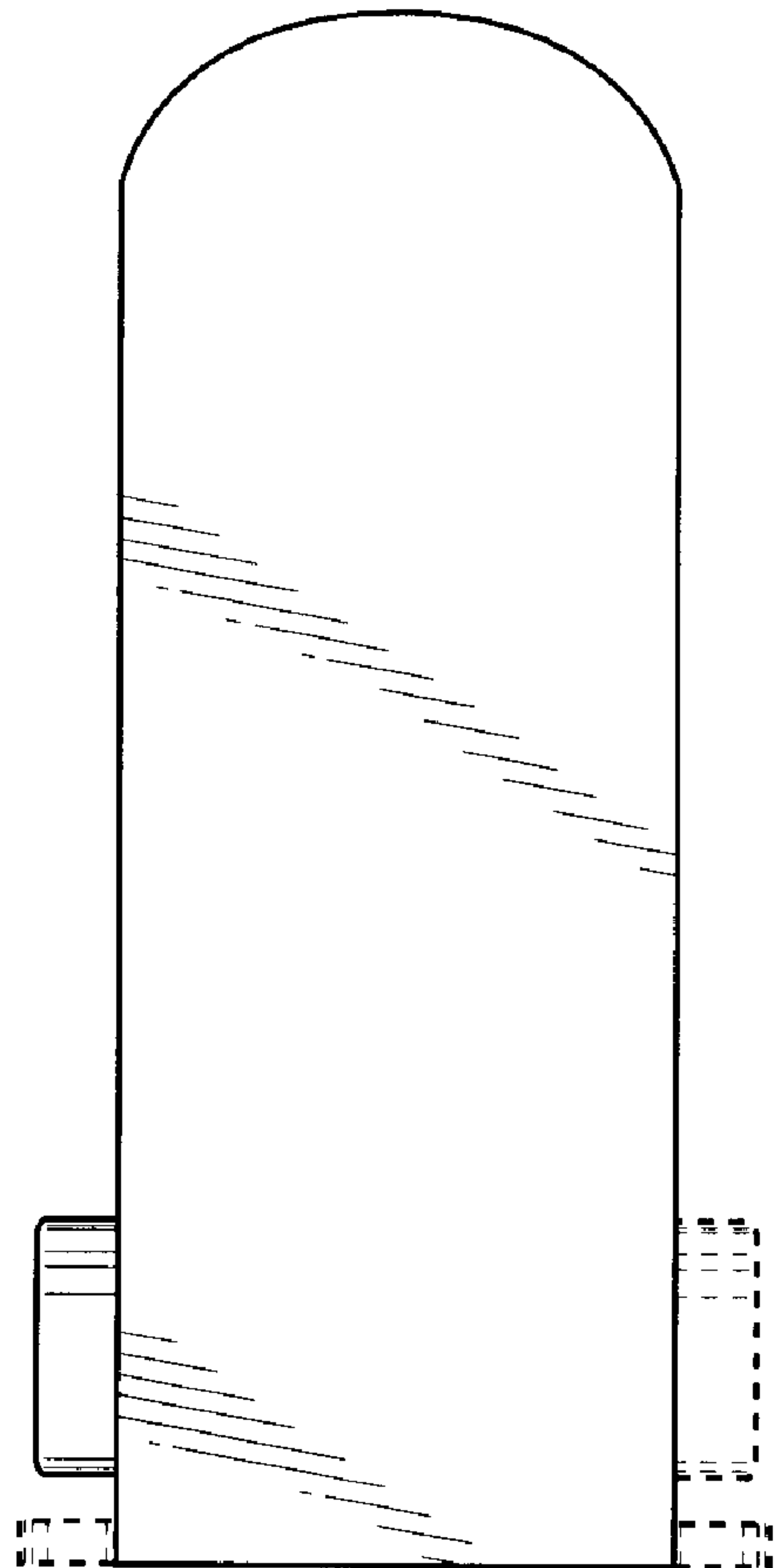

Fig. 28

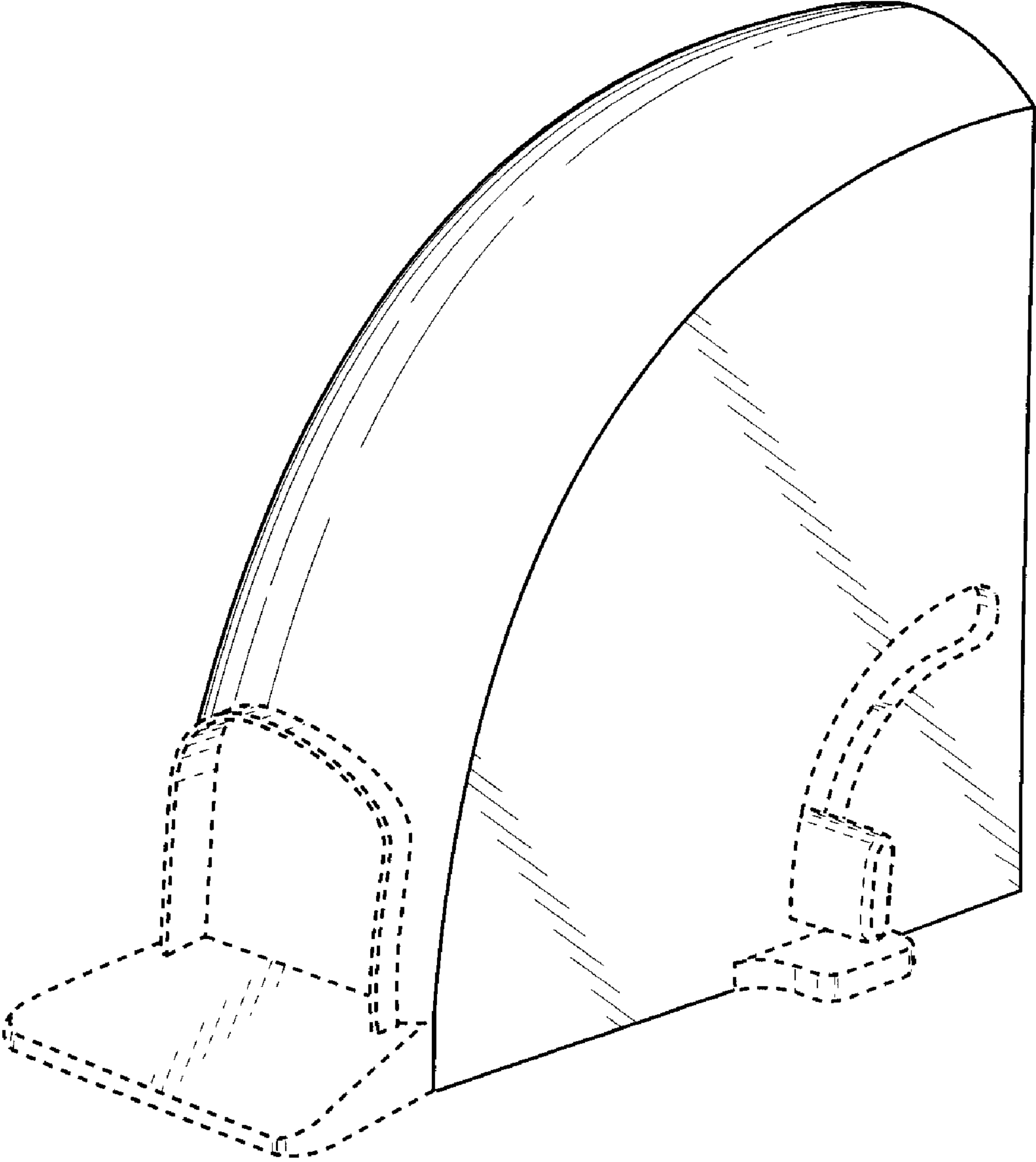

Fig. 29

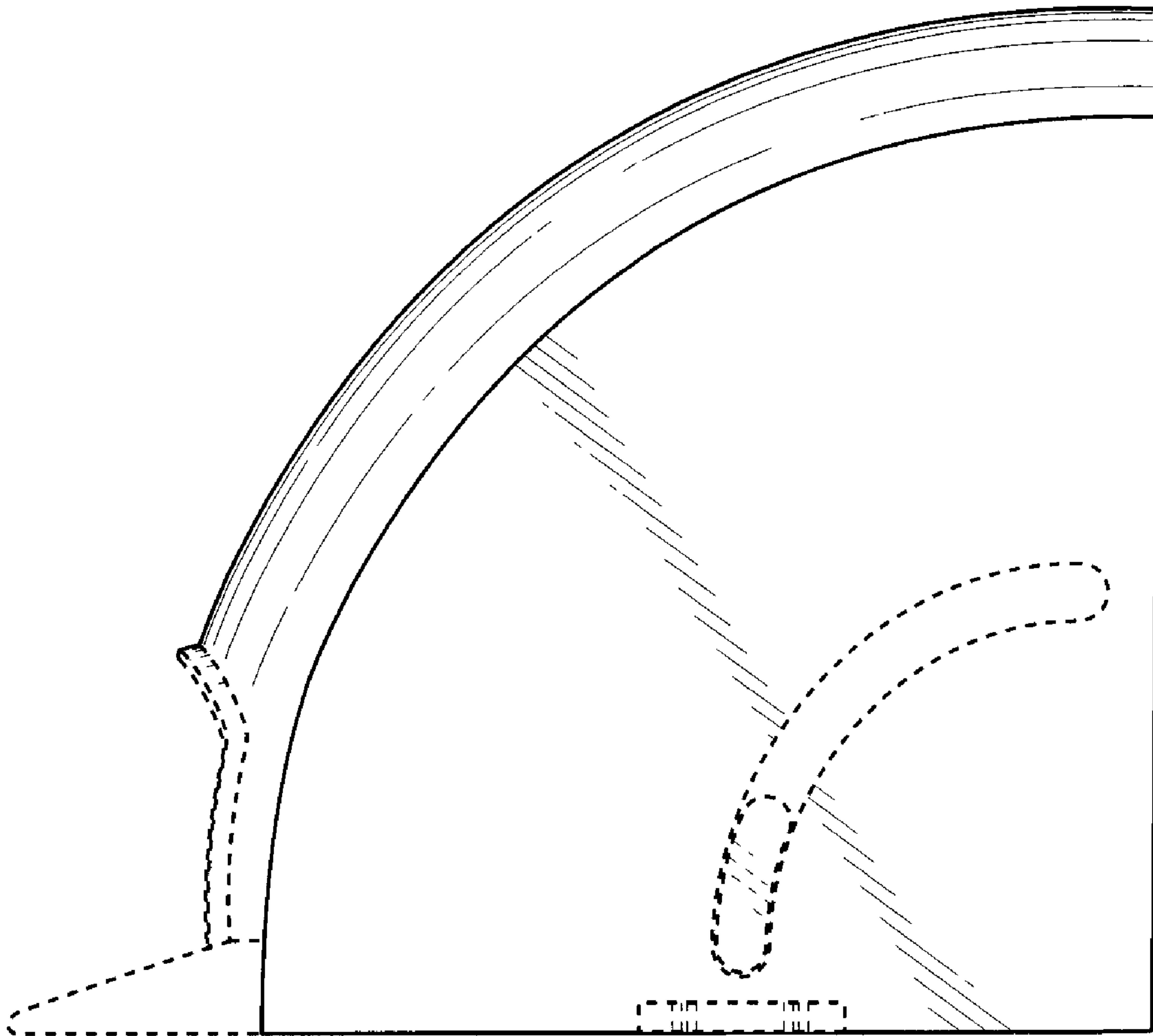

Fig. 30

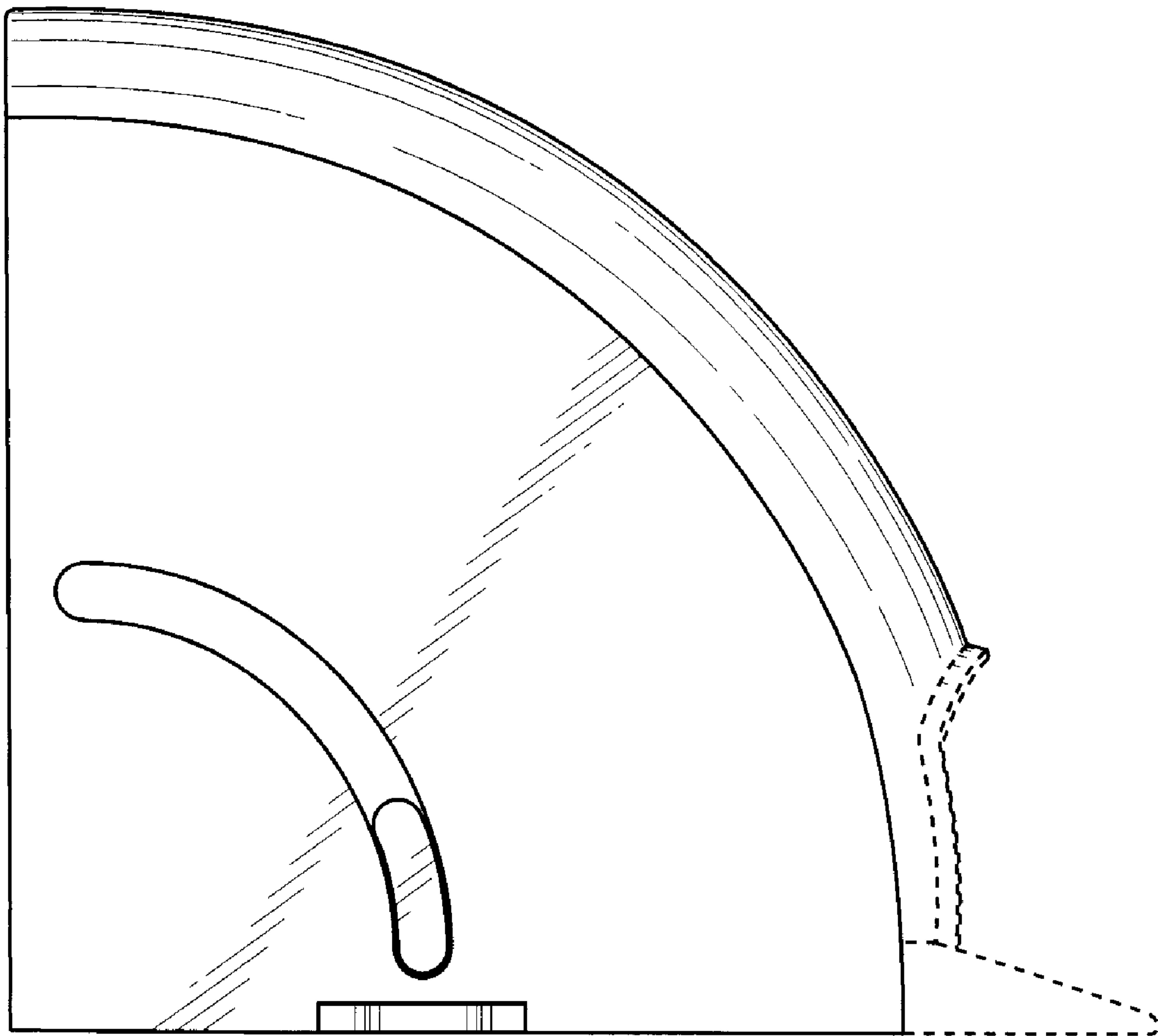

Fig. 31

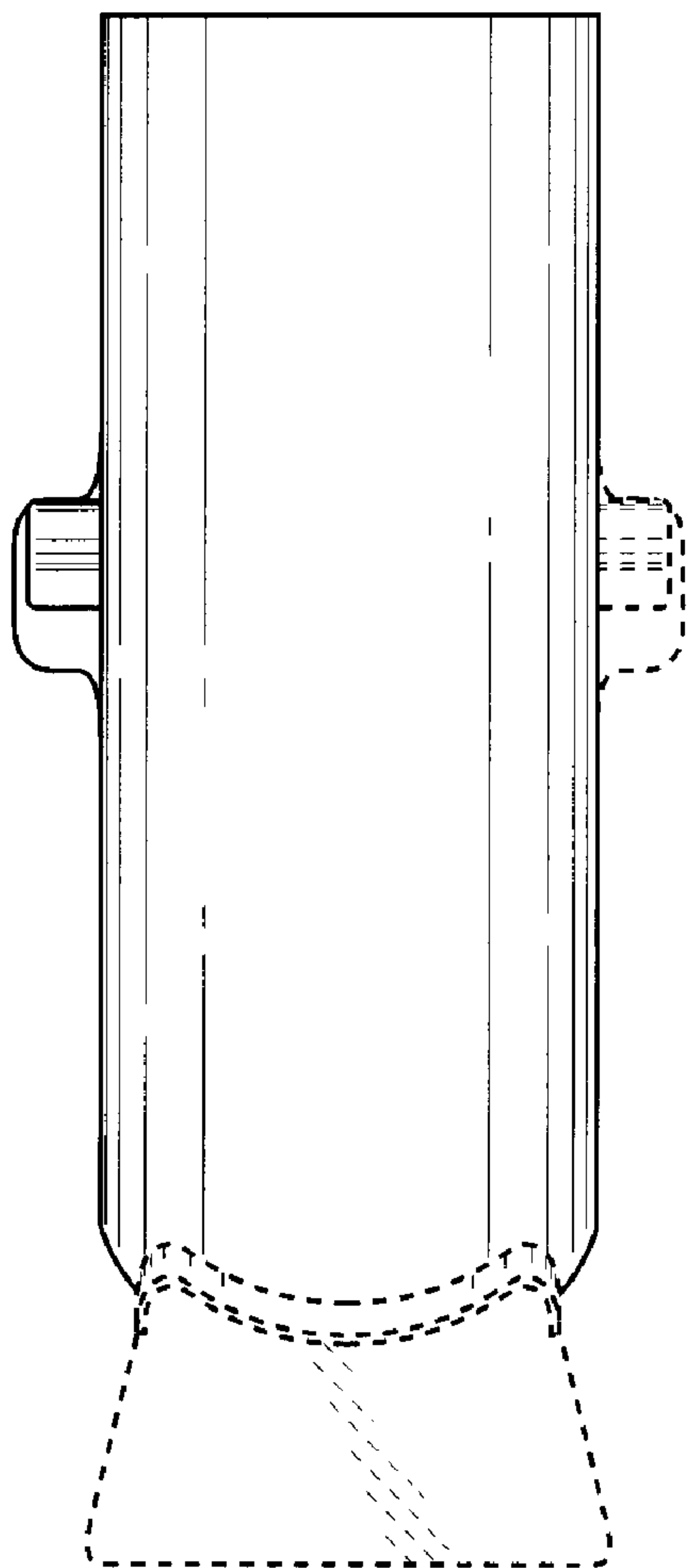

Fig. 32

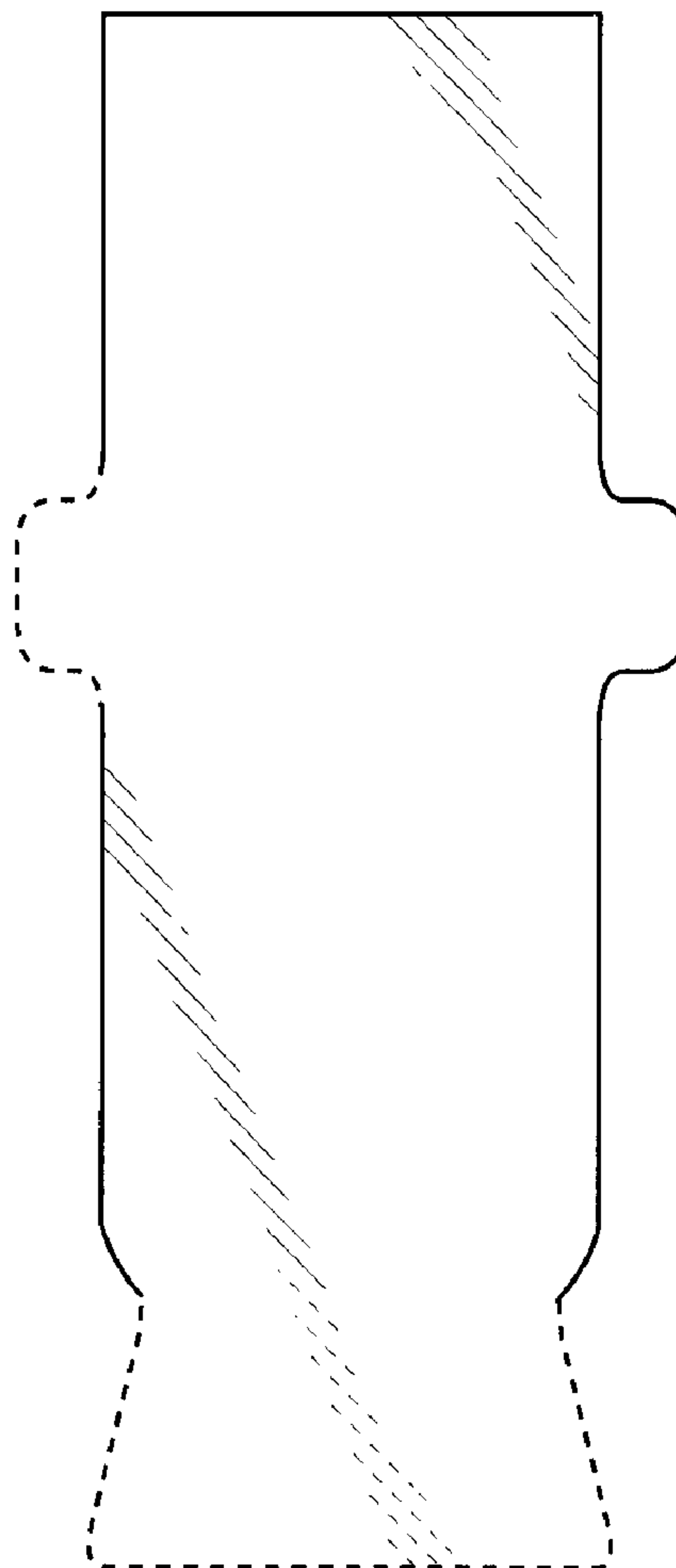

Fig. 33

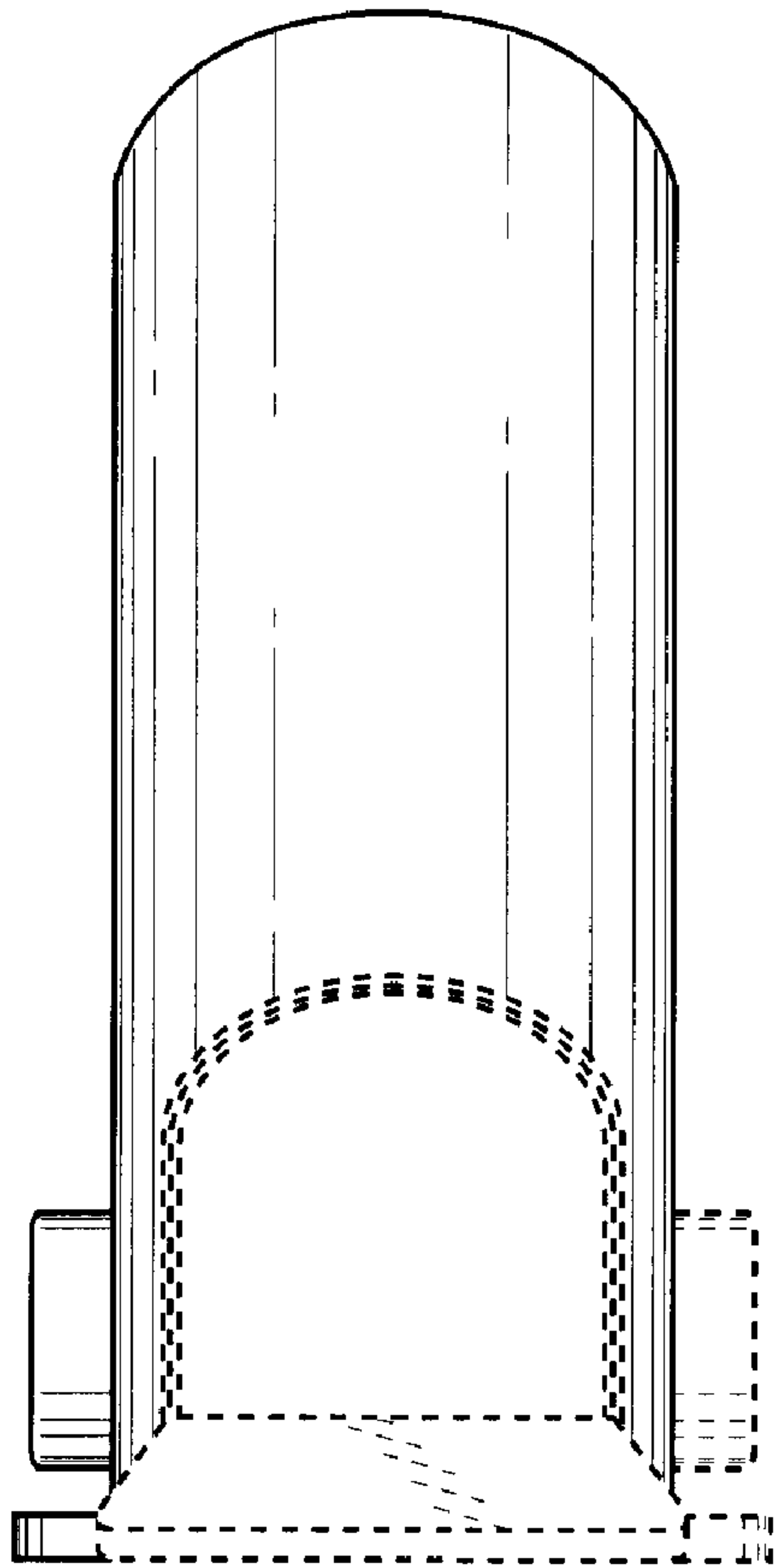

Fig. 34

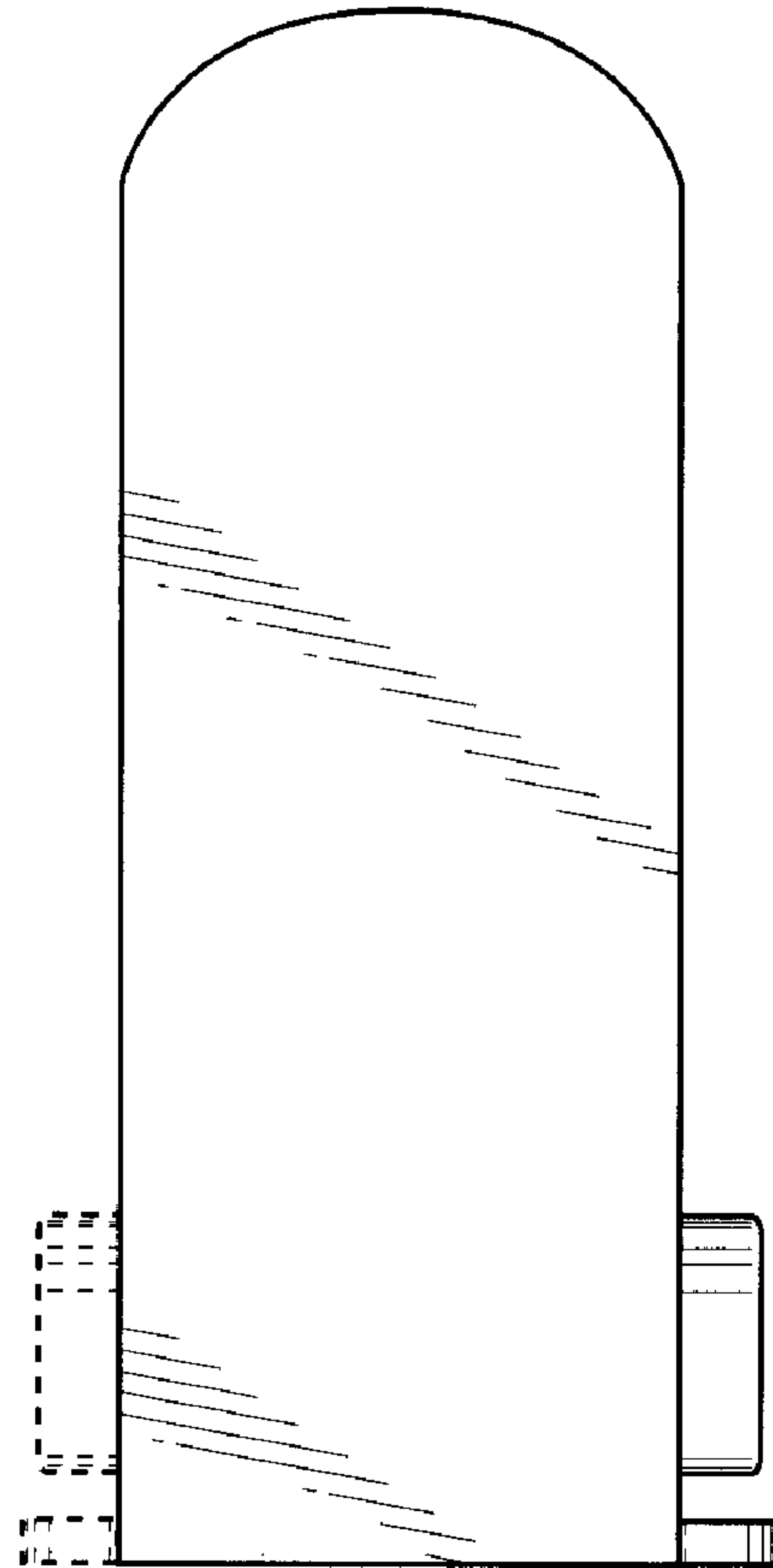

Fig. 35

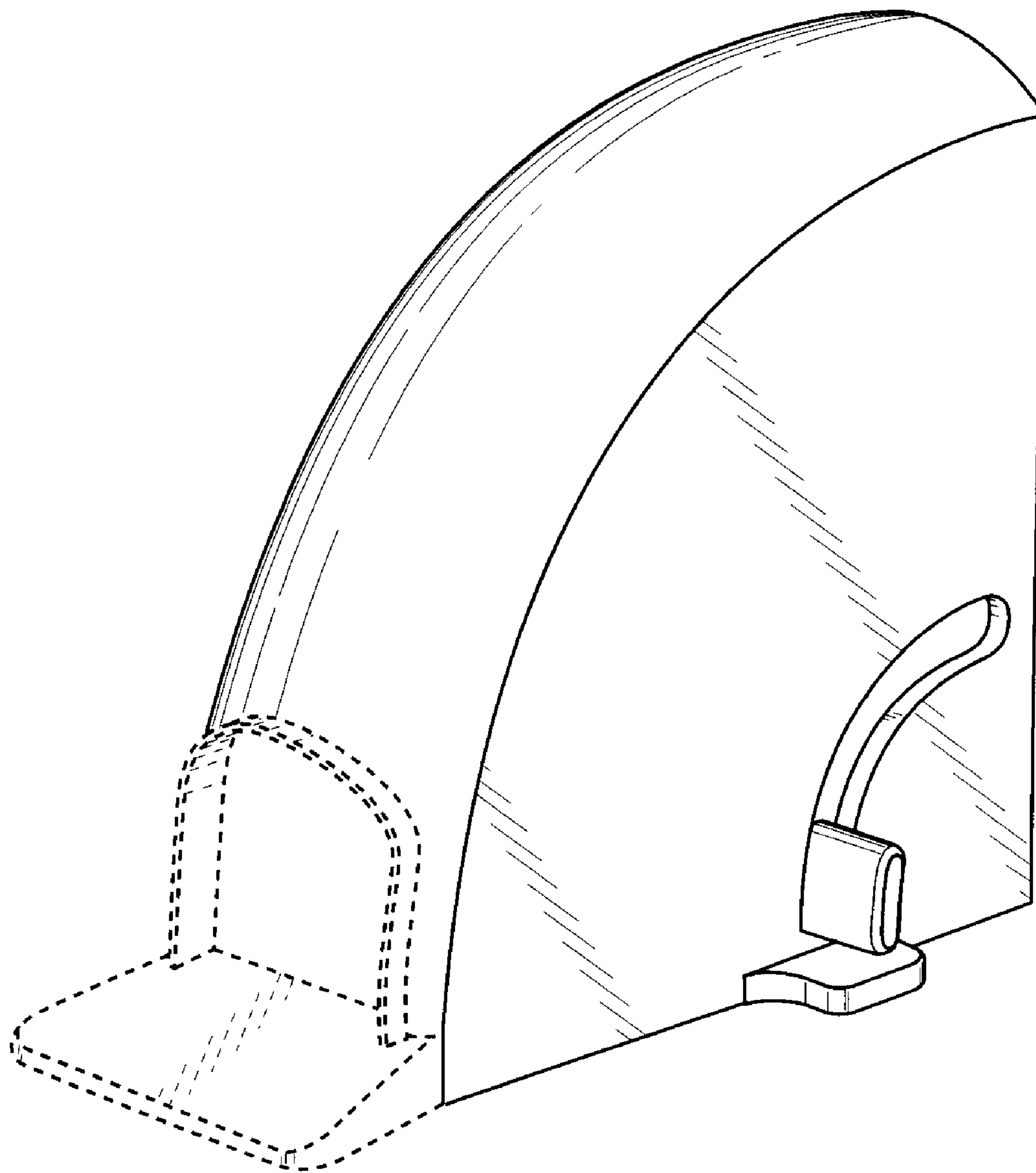

Fig. 36

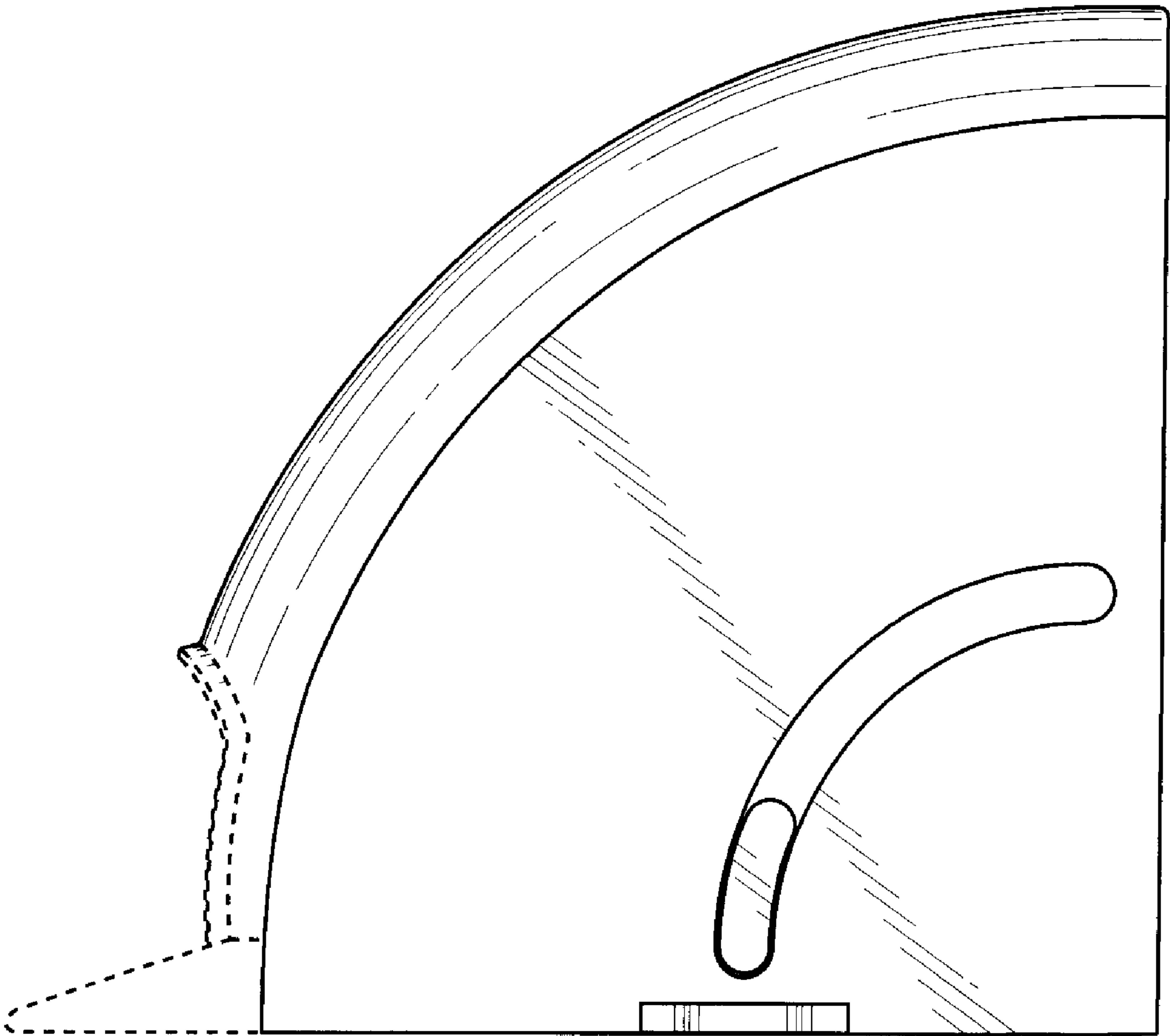

Fig. 37

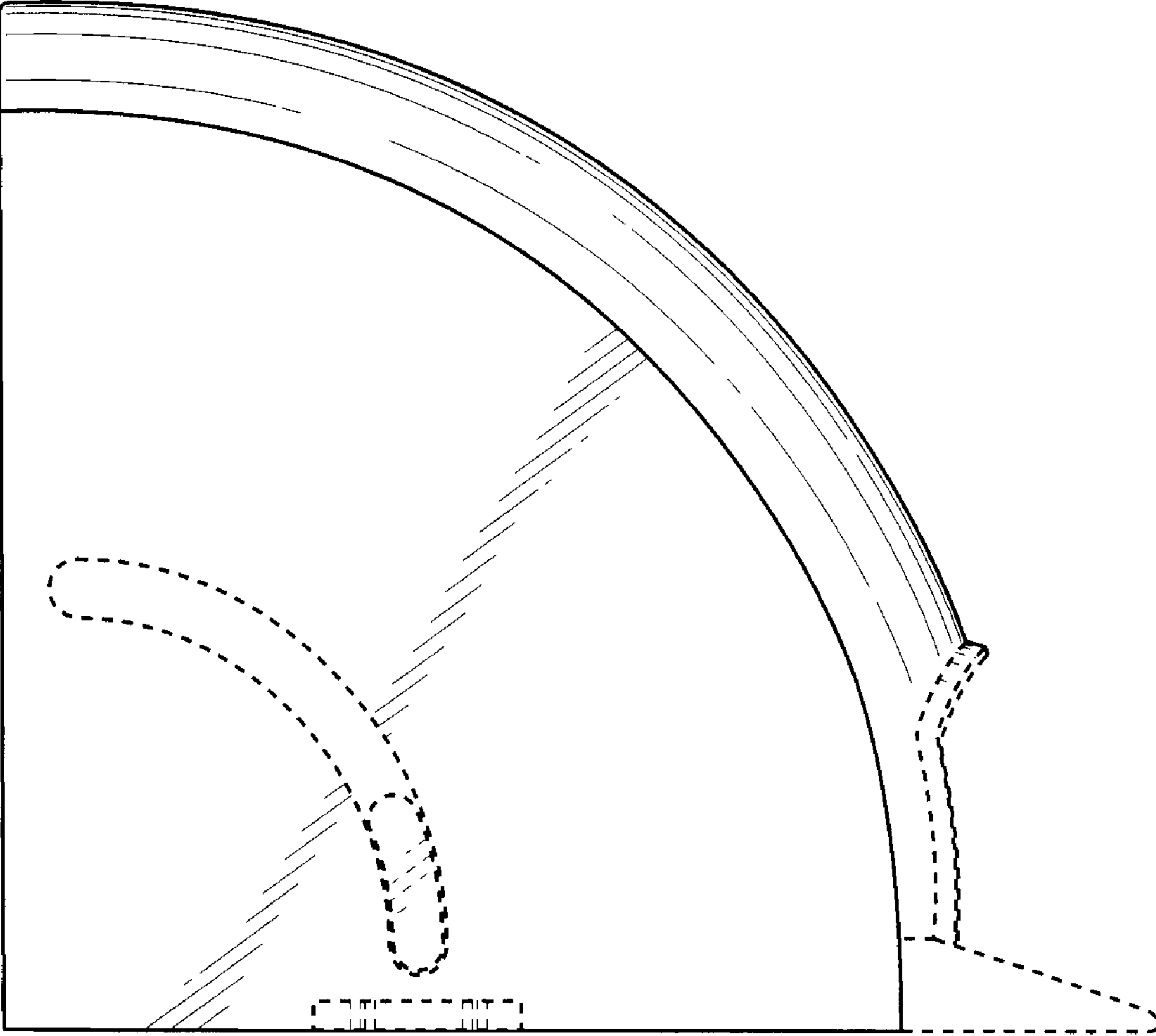

Fig. 38

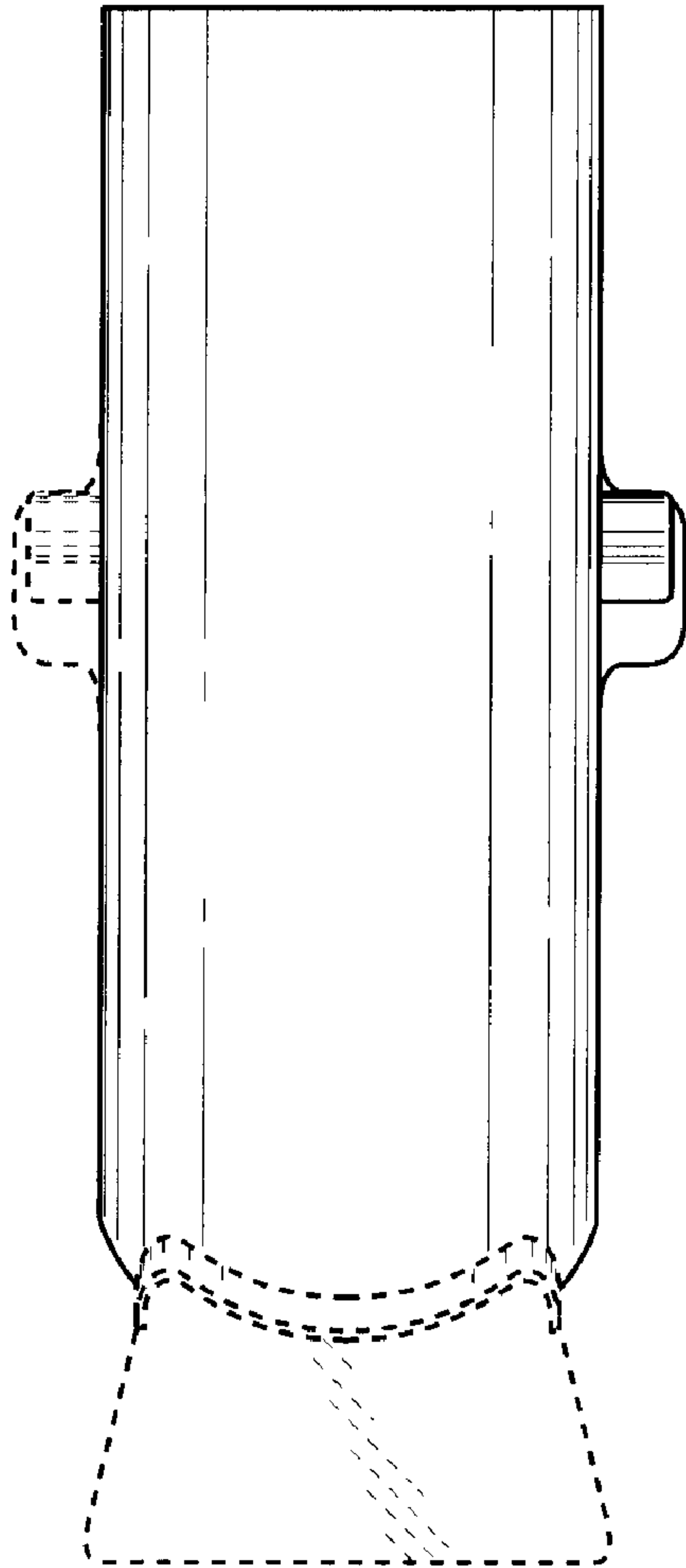

Fig. 39

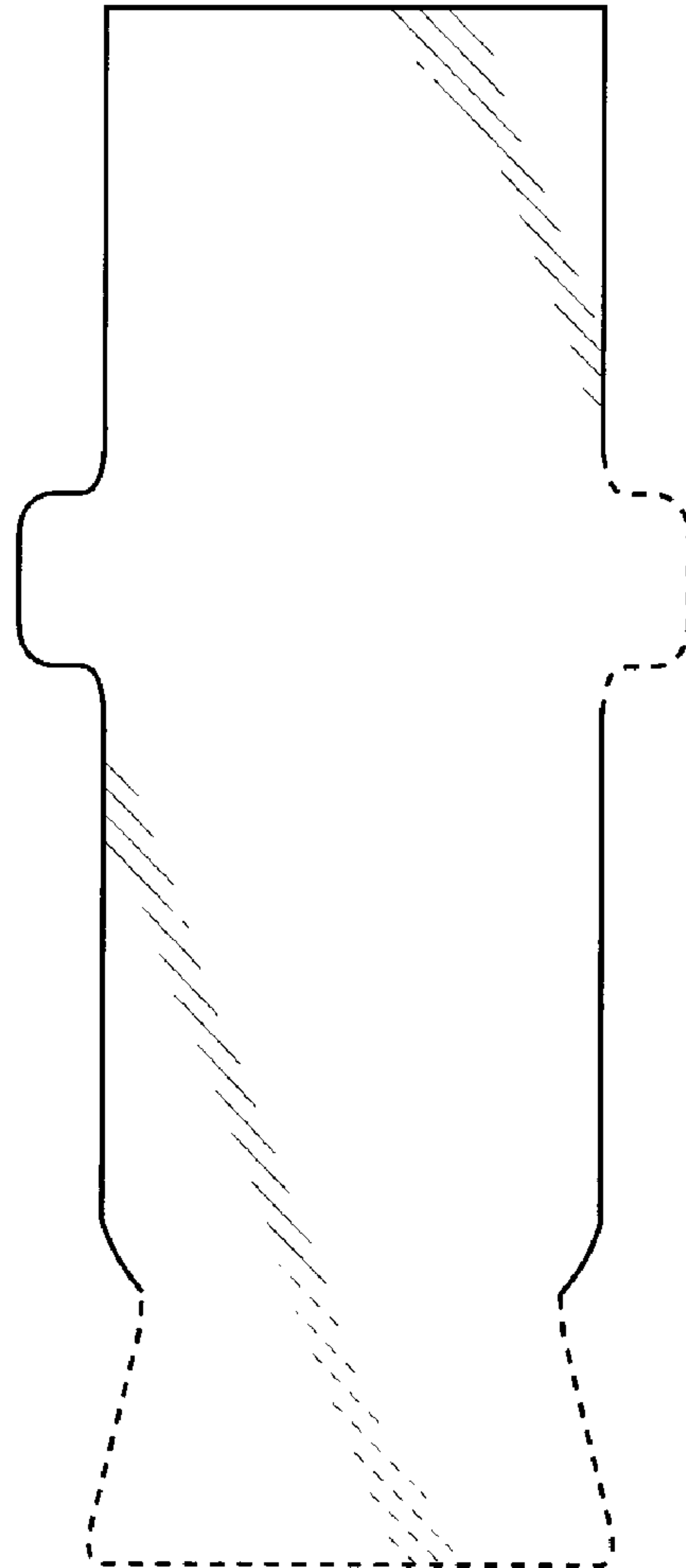

Fig. 40

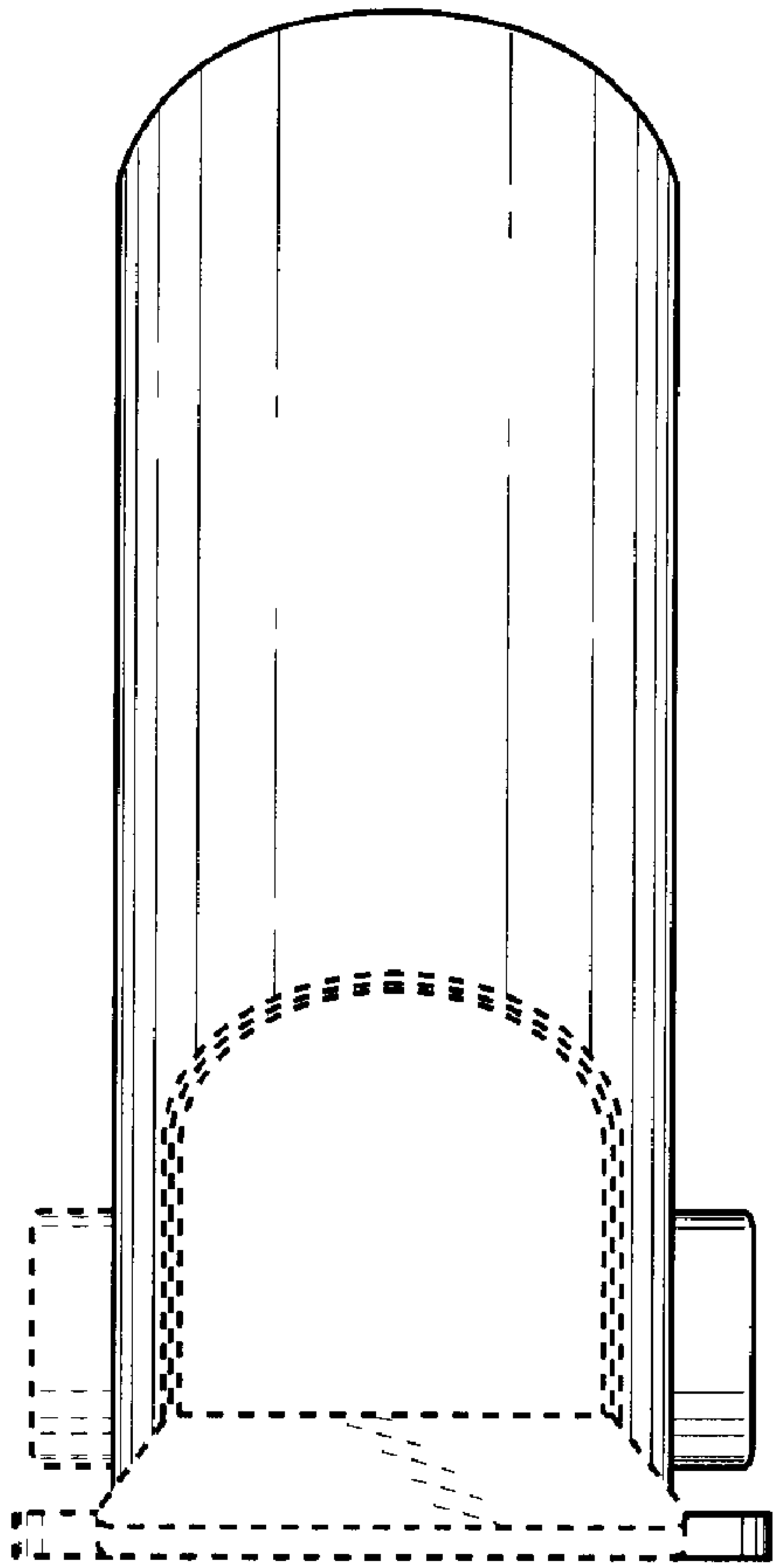

Fig. 41

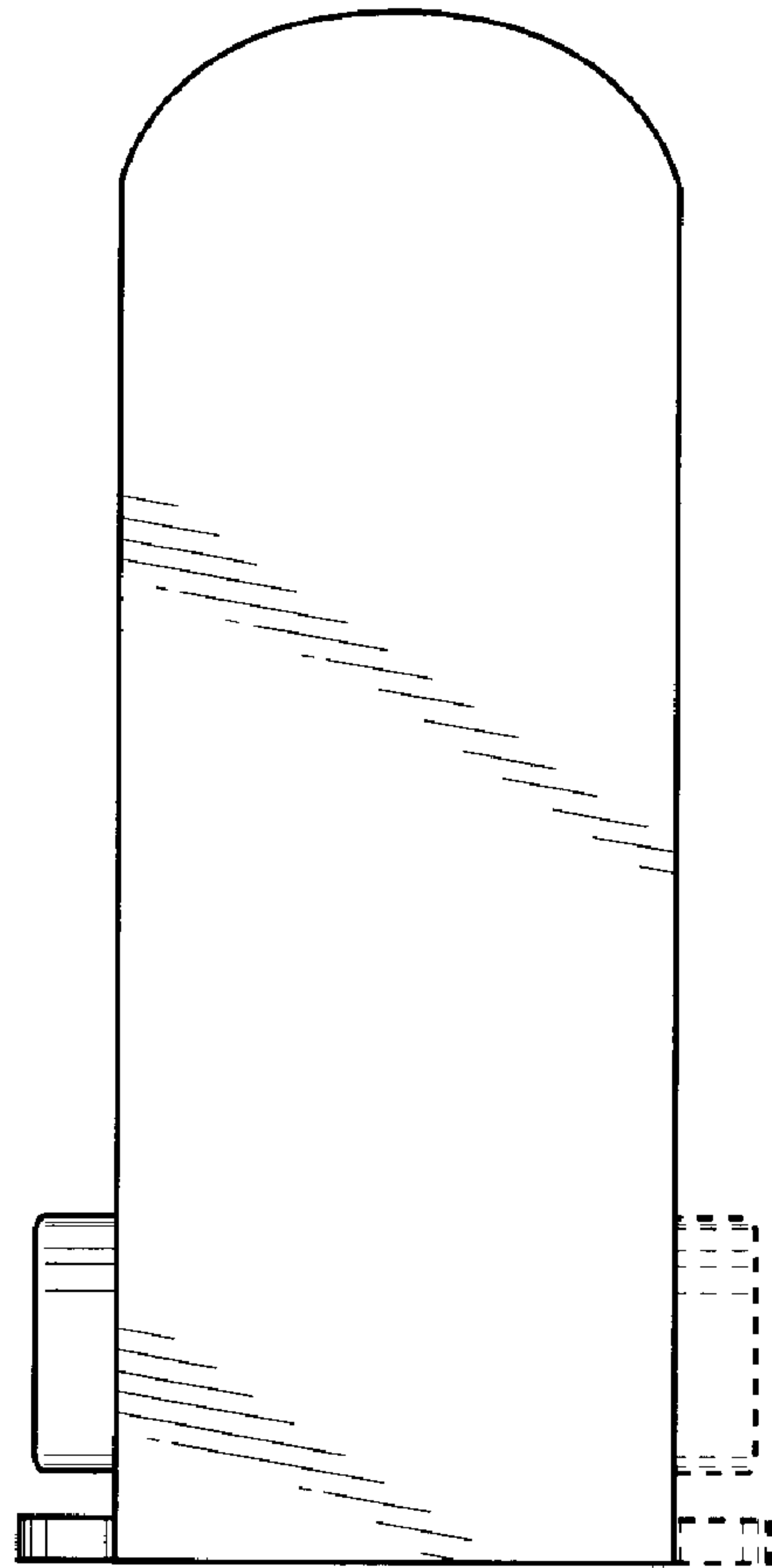

Fig. 42

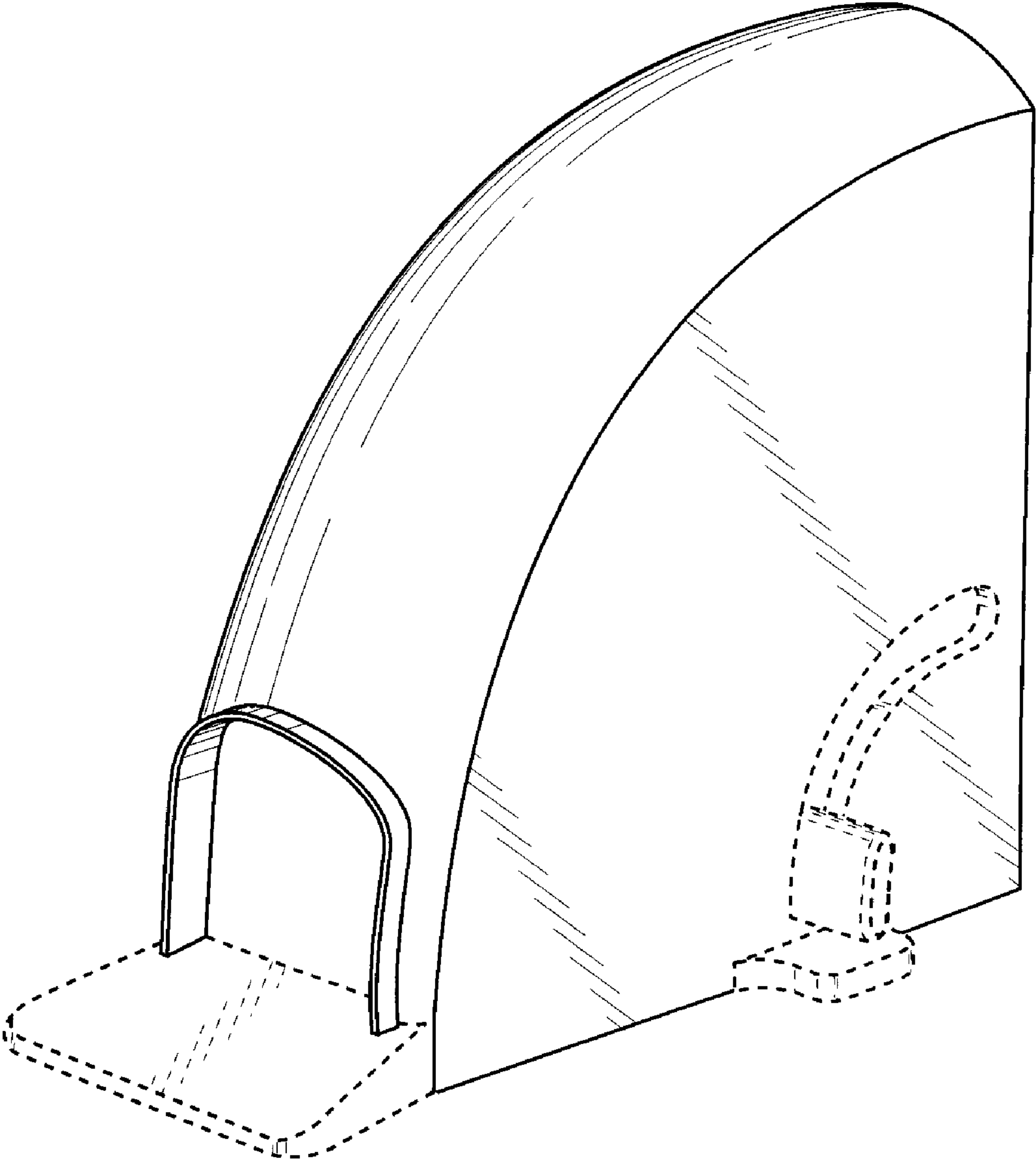

Fig. 43

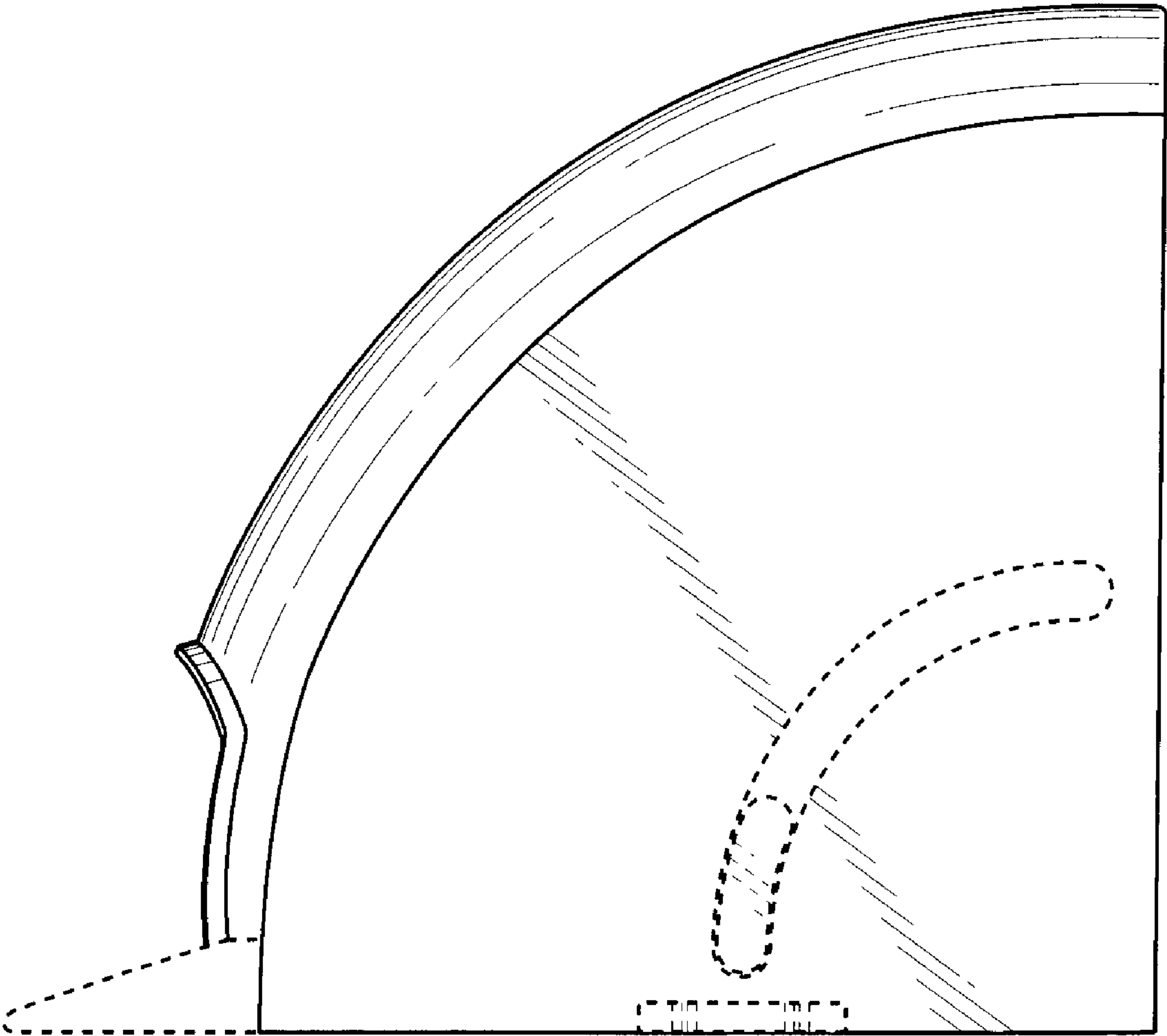

Fig. 44

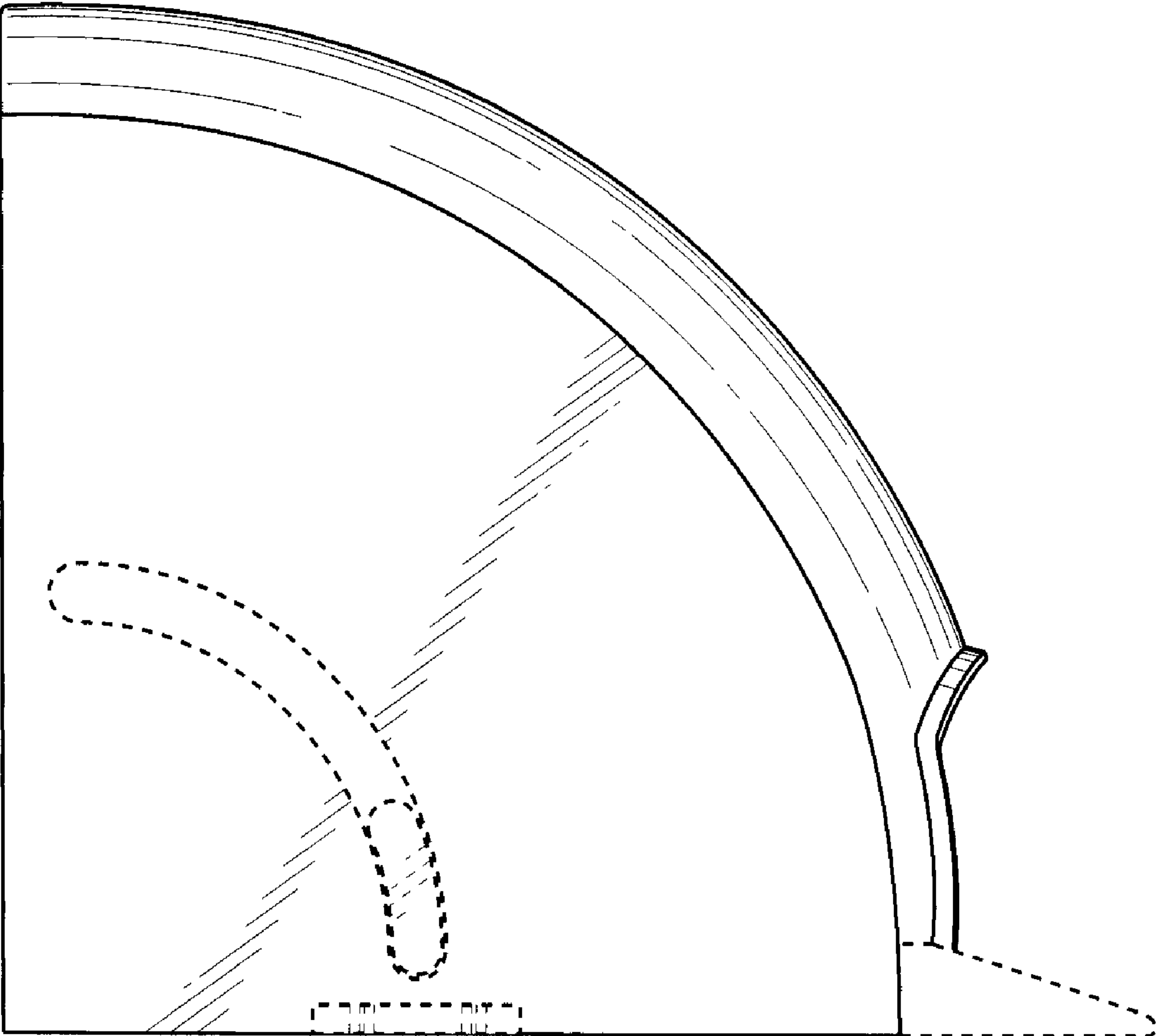

Fig. 45

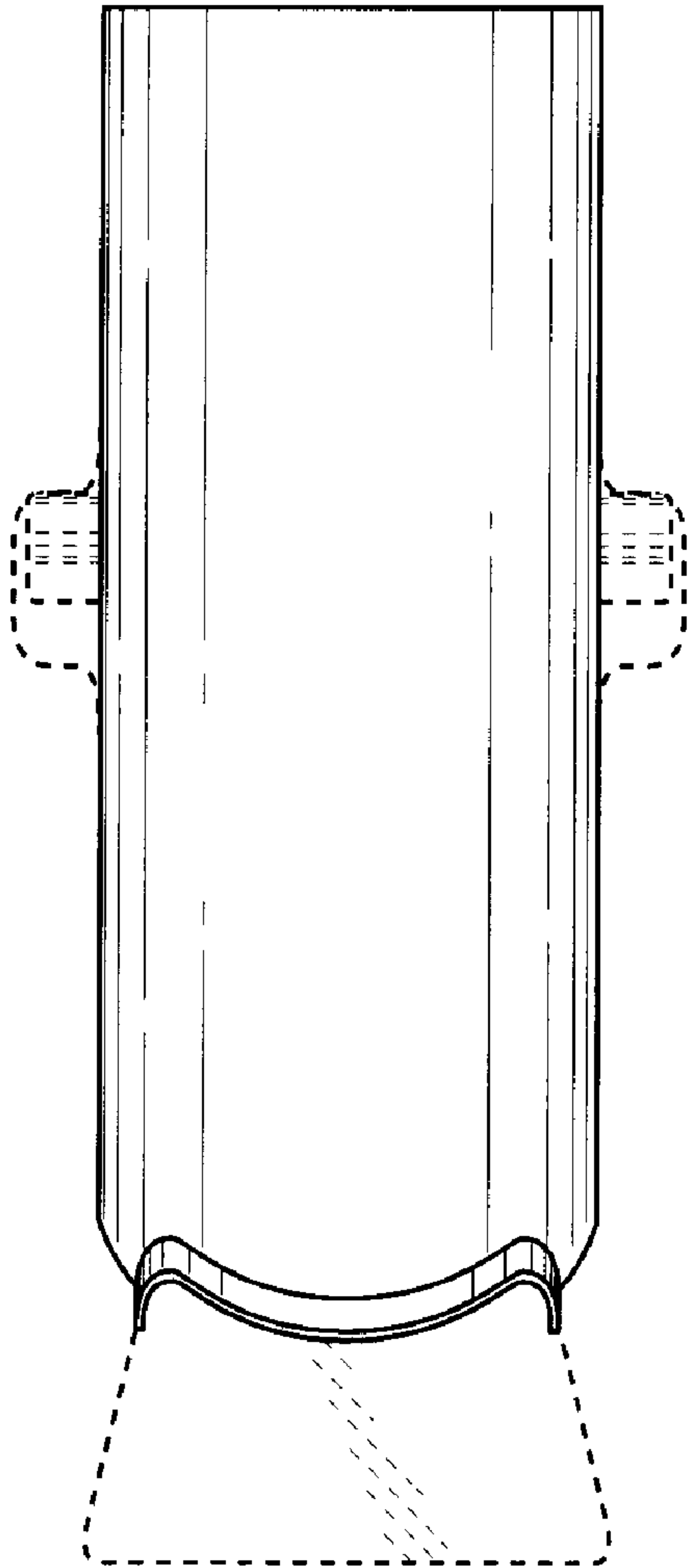

Fig. 46

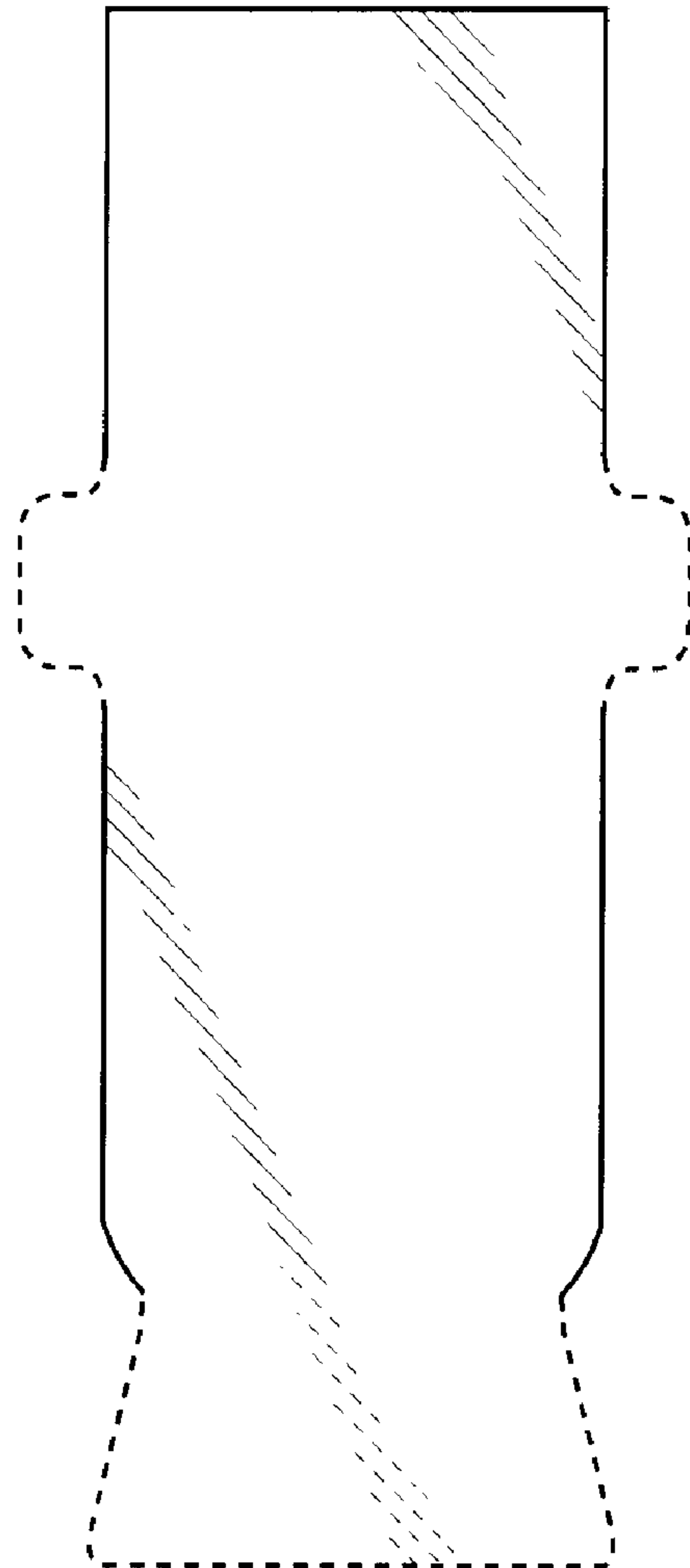

Fig. 47

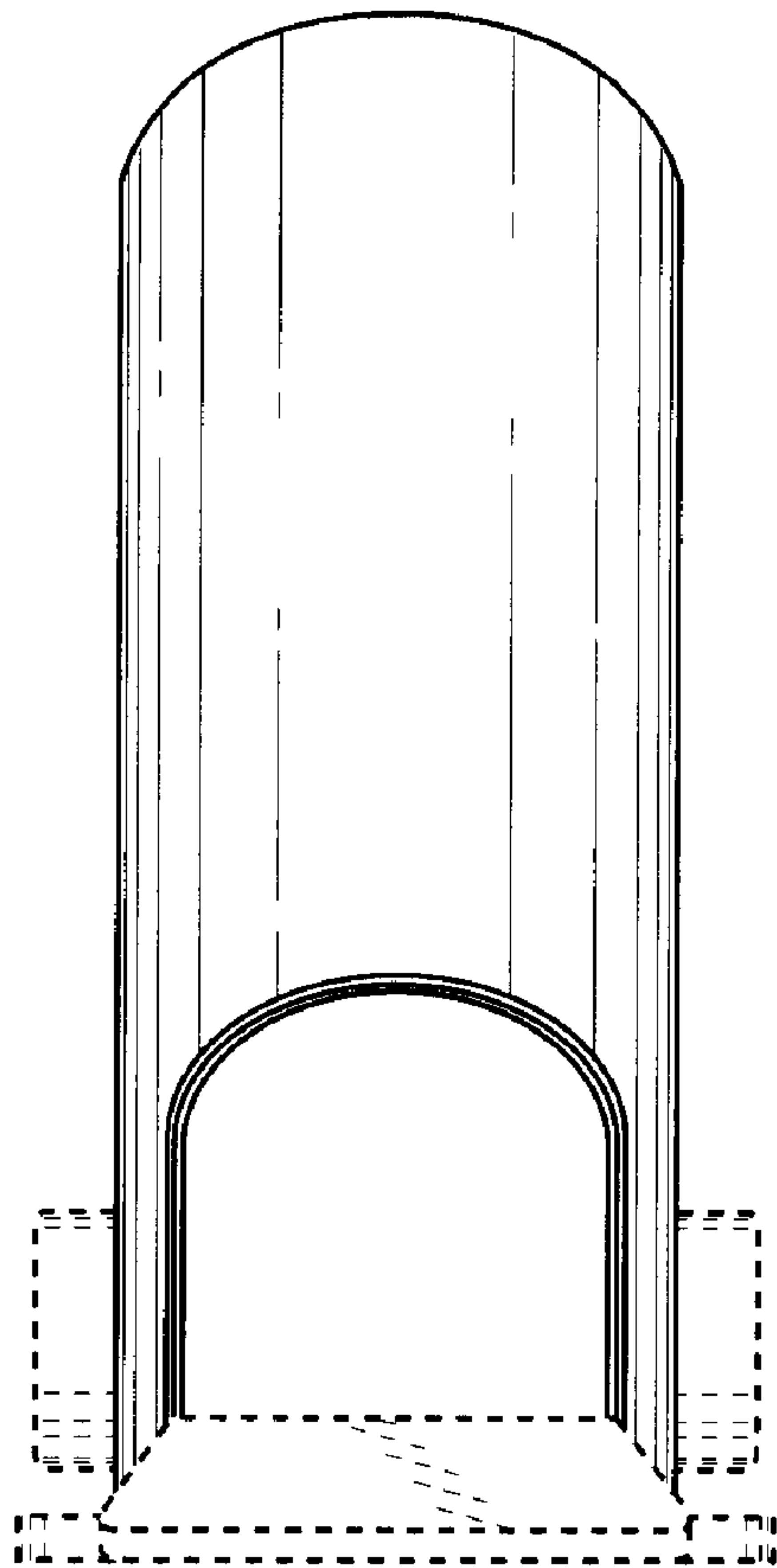

Fig. 48

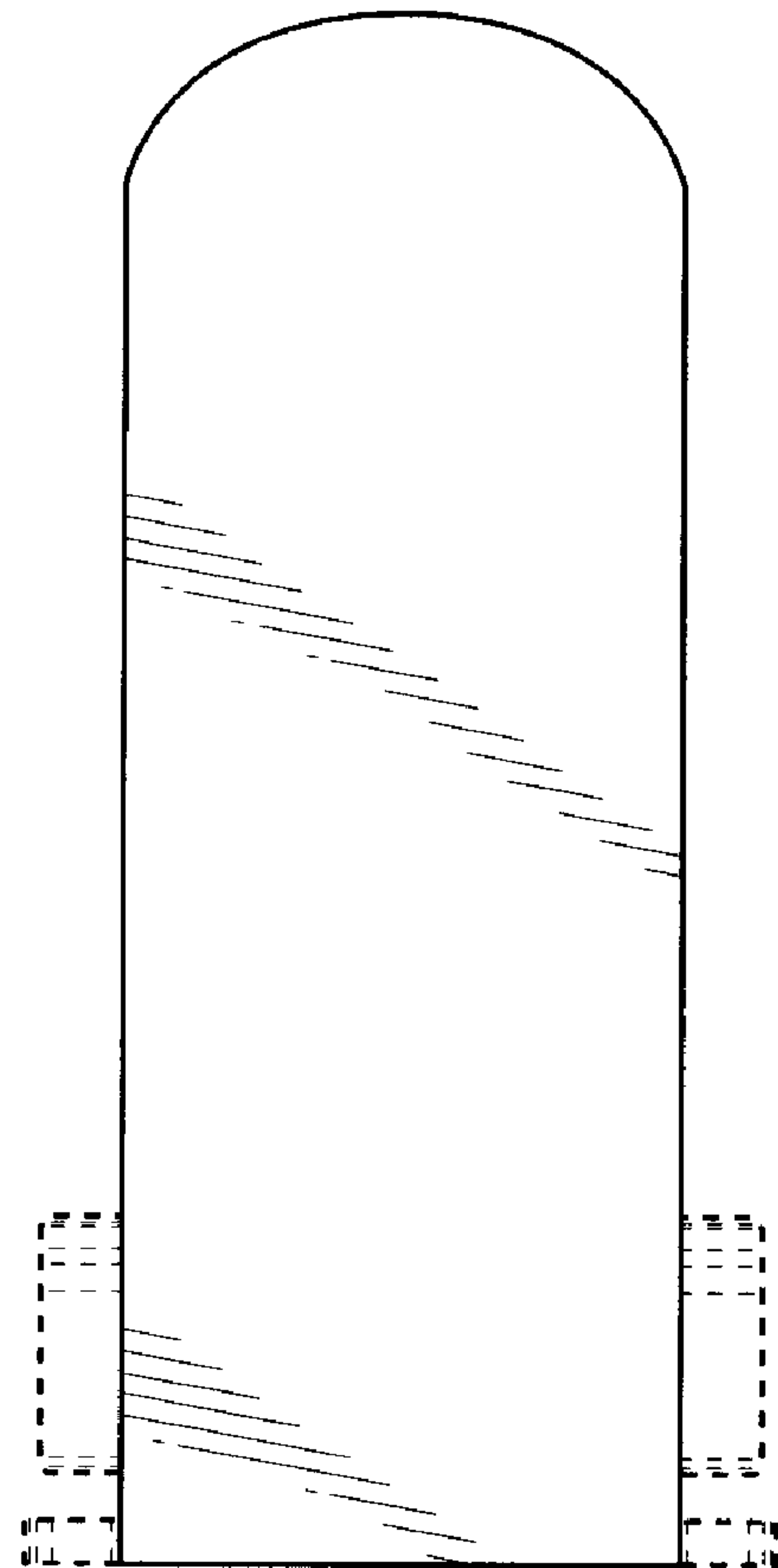

Fig. 49

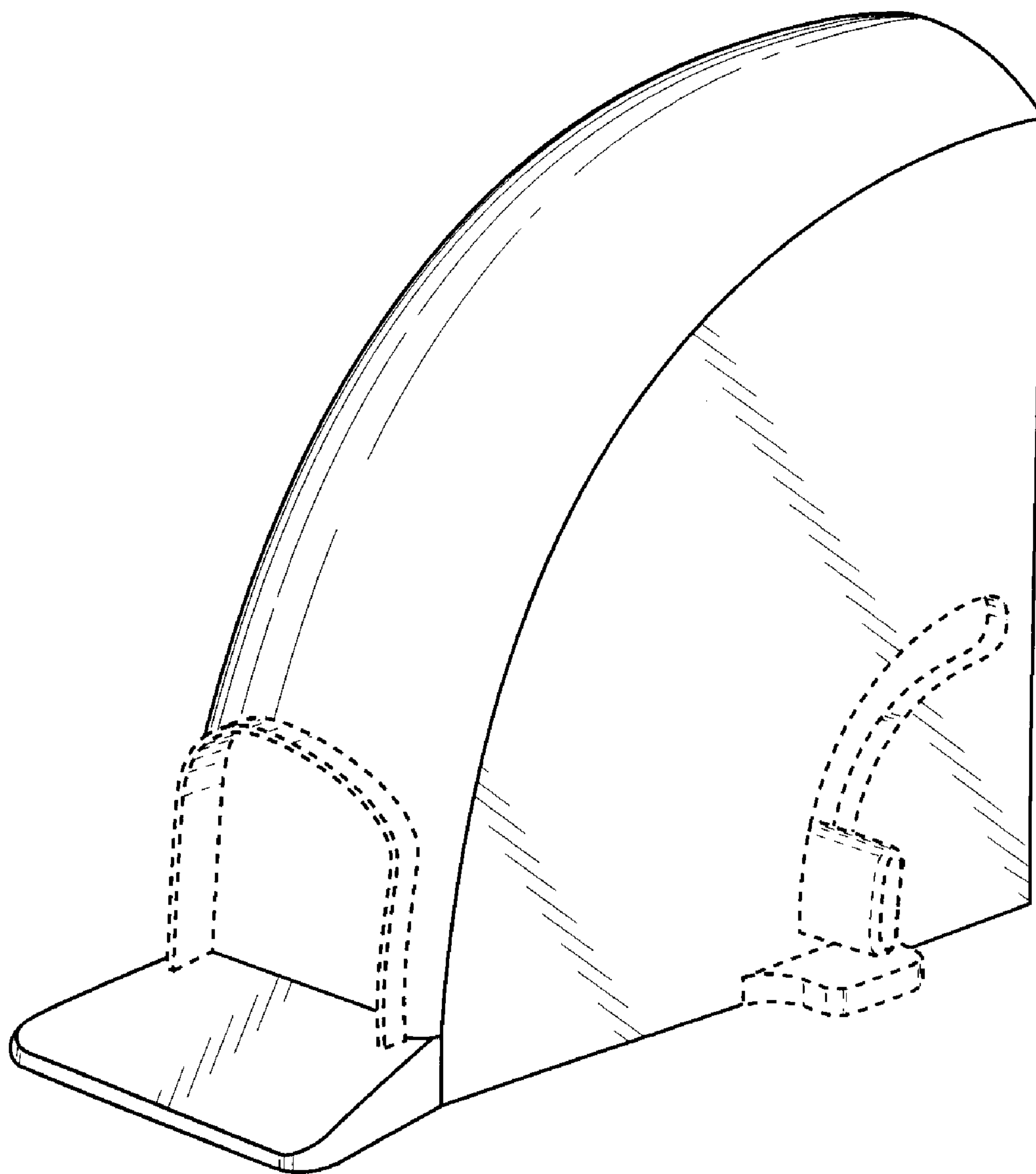

Fig. 50

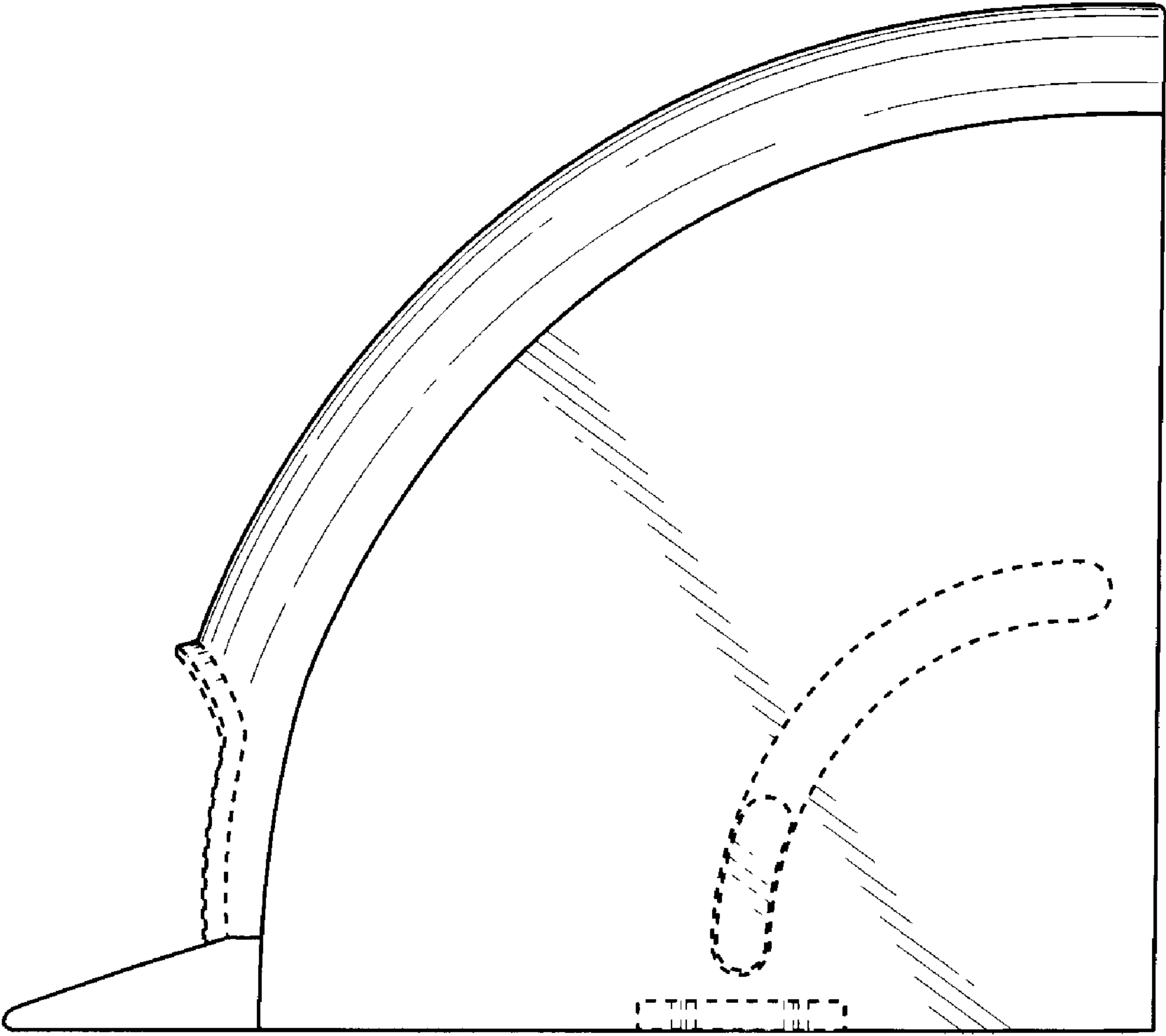

Fig. 51

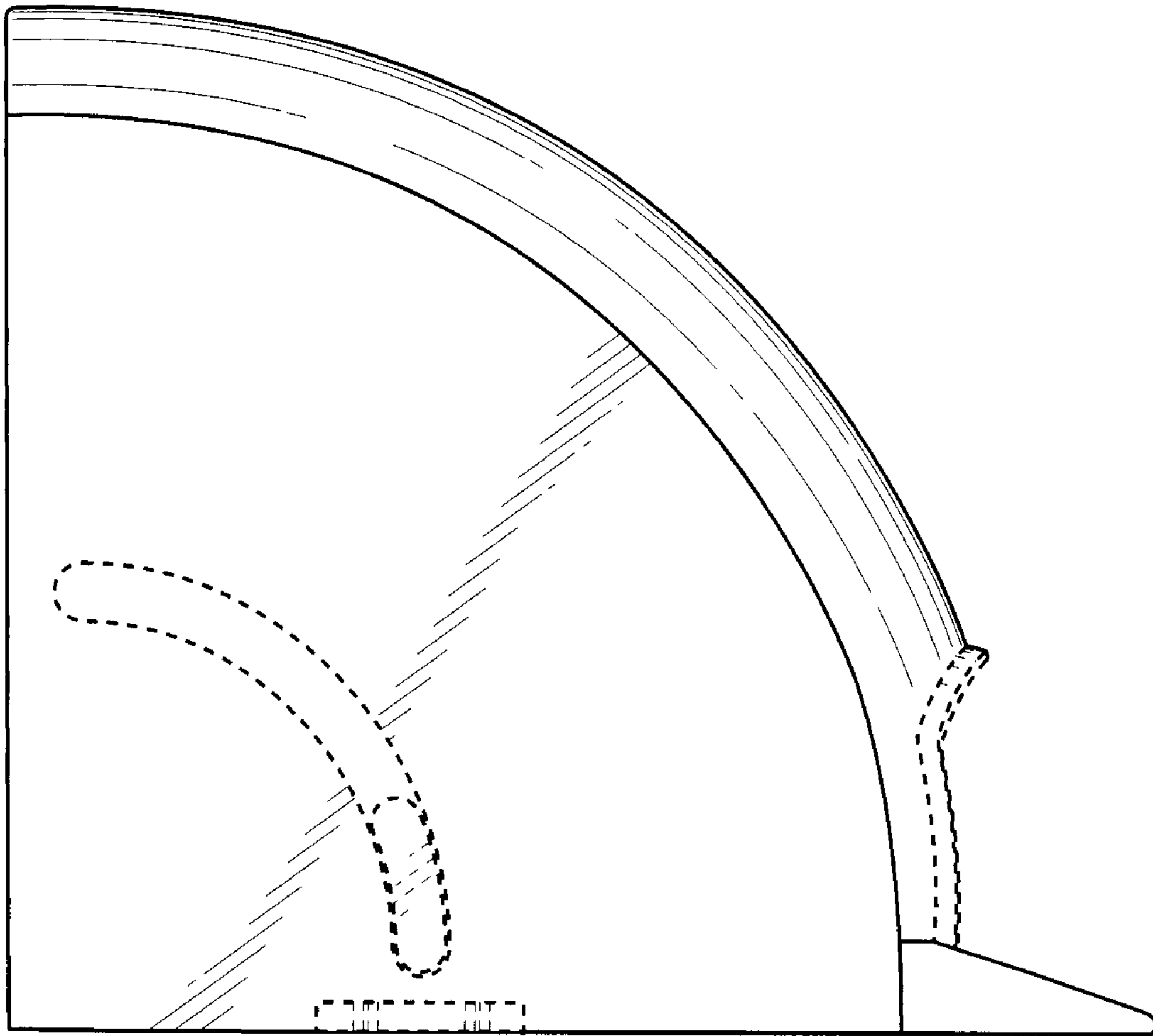

Fig. 52

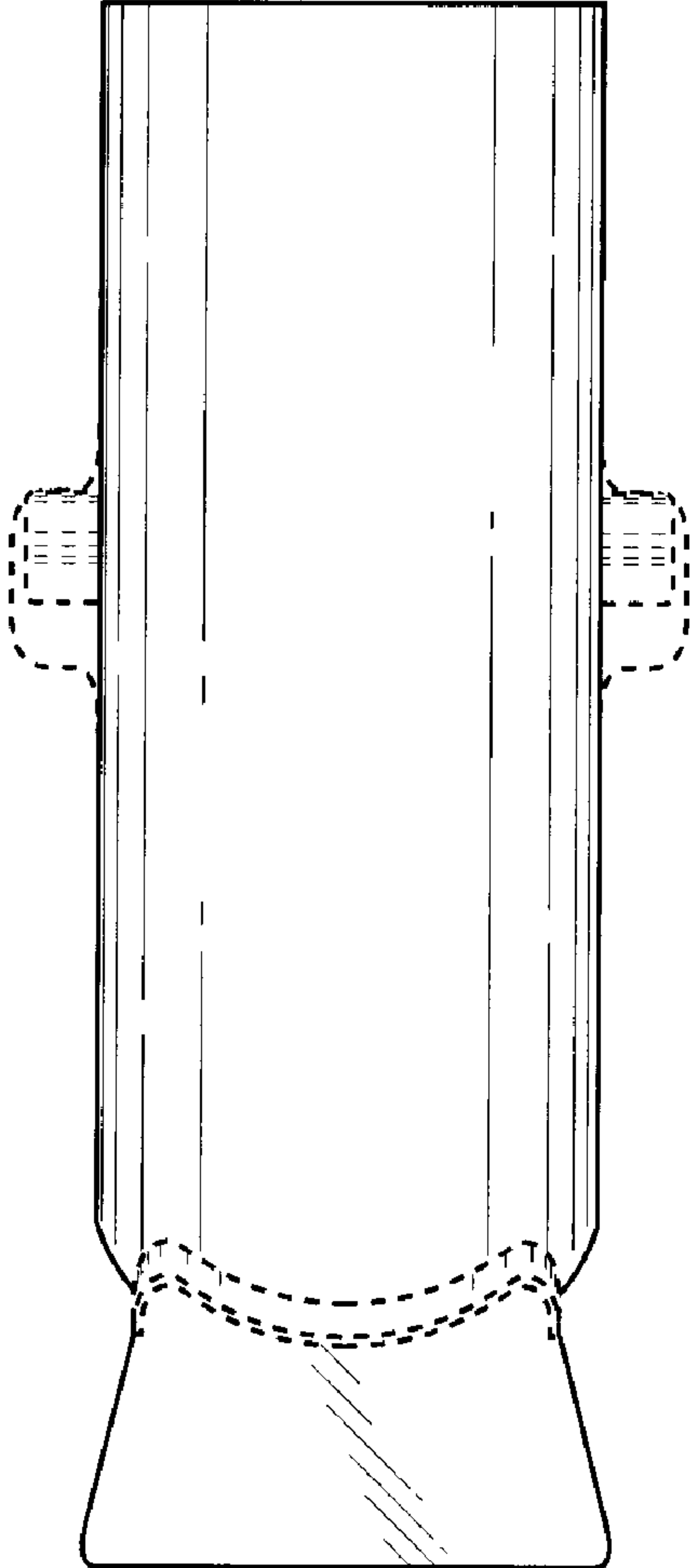

Fig. 53

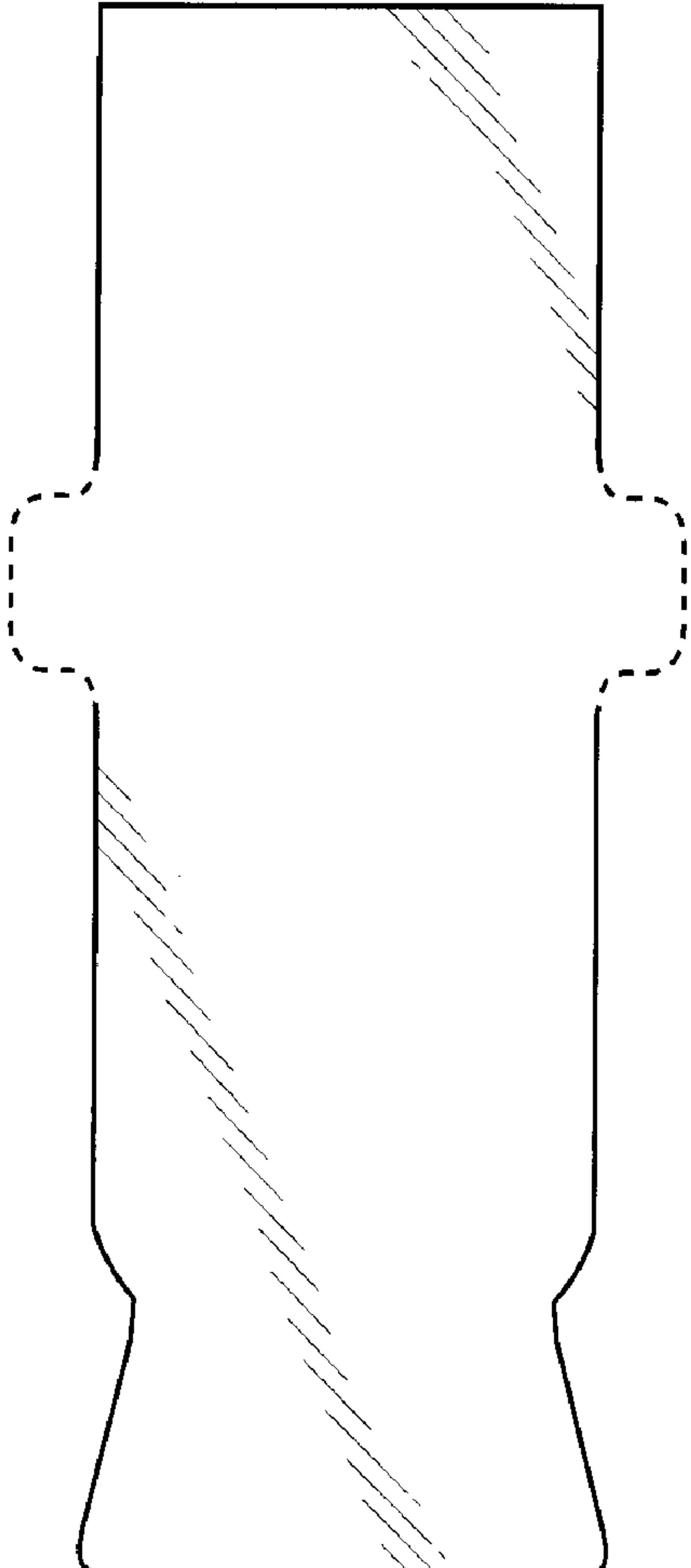

Fig. 54

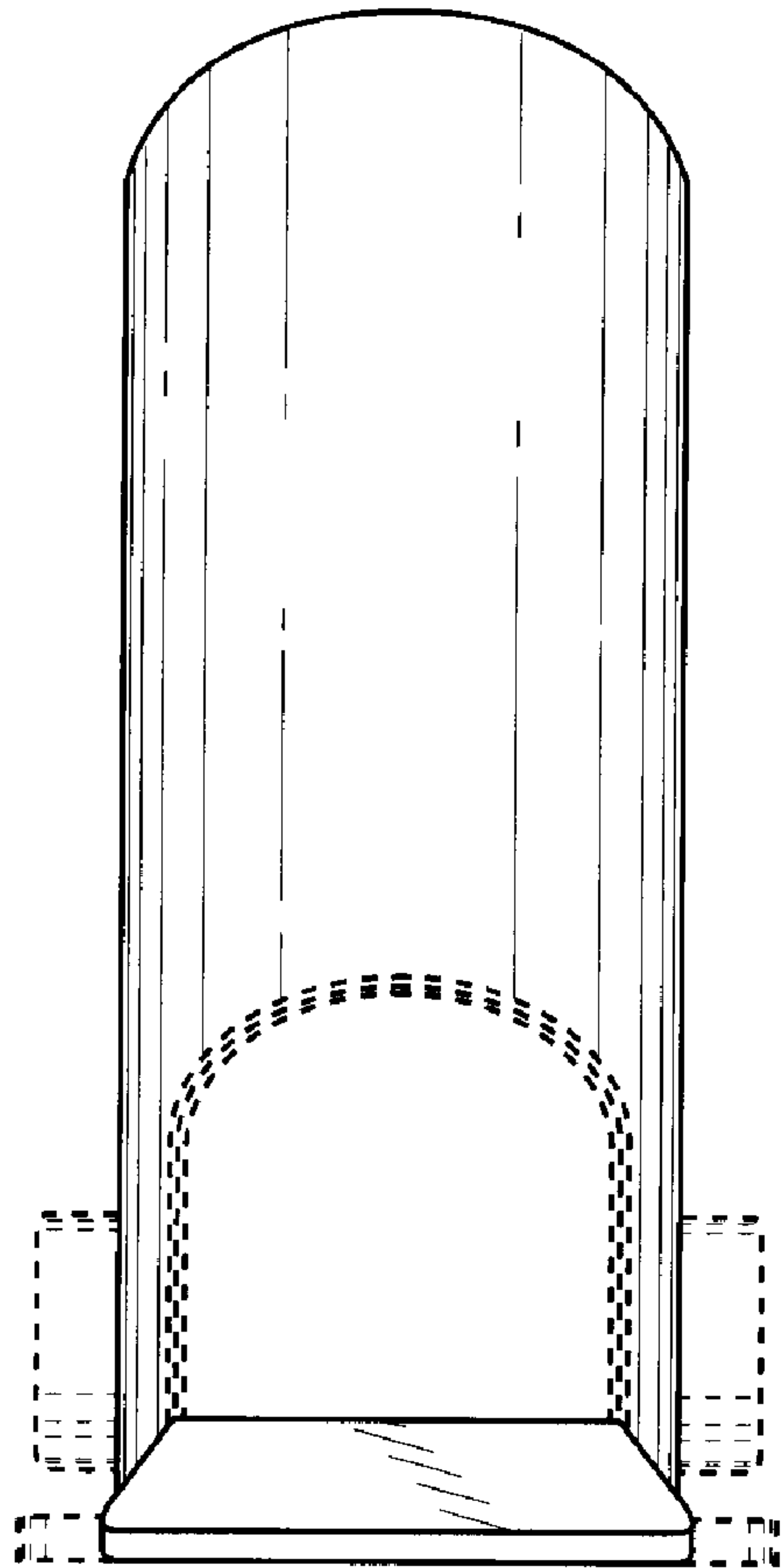

Fig. 55

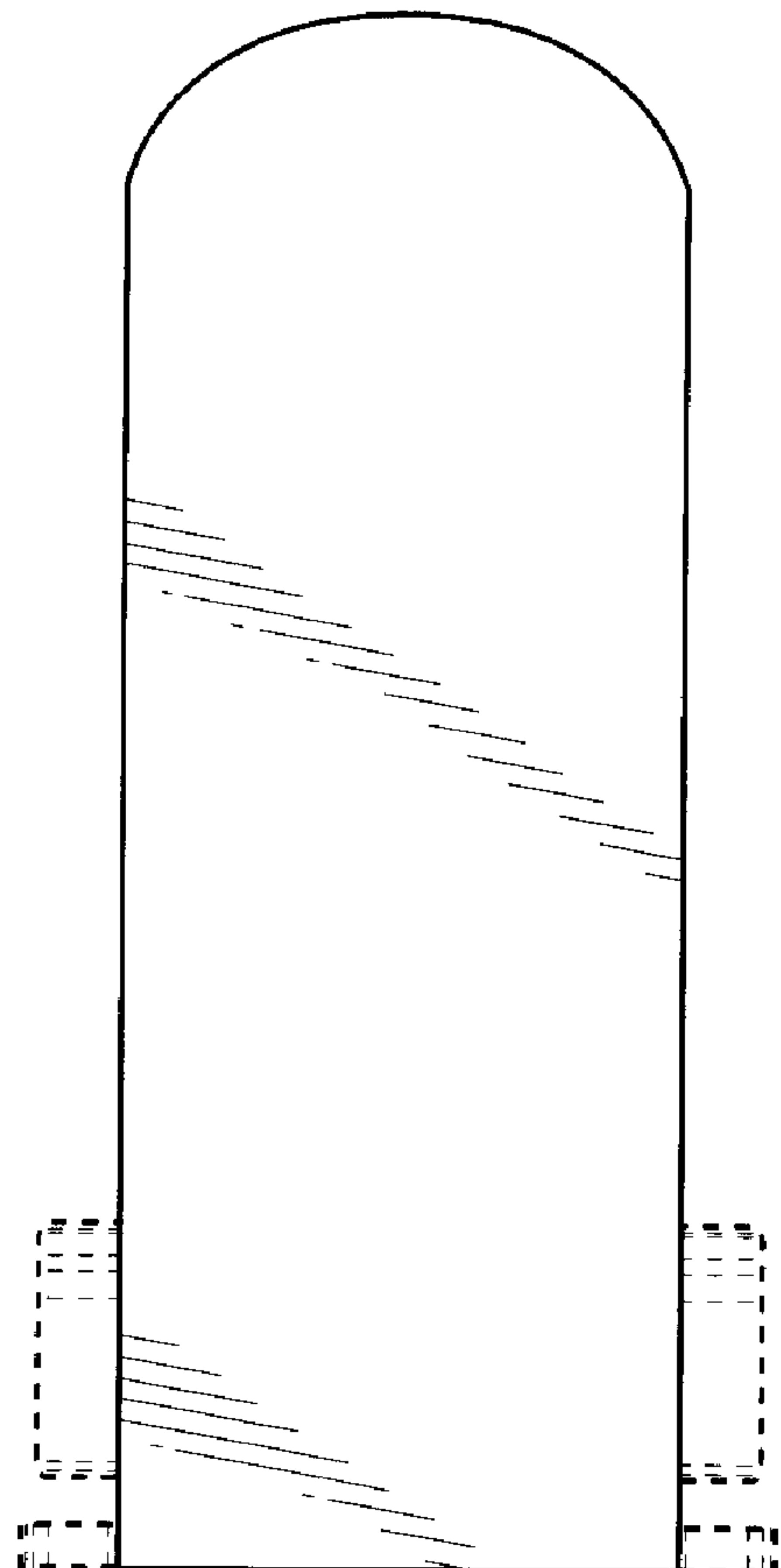

Fig. 56