



US00D577173S

(12) **United States Design Patent**
Pitchford et al.

(10) **Patent No.:** **US D577,173 S**
(45) **Date of Patent:** **** Sep. 16, 2008**

(54) **CARRIER FOR PORTABLE HEATER**

(75) Inventors: **Eric Pitchford**, Bowling Green, KY (US); **Griffin Bland**, Bowling Green, KY (US); **Craig Higginbotham**, Bowling Green, KY (US); **Pete Moyer**, Bowling Green, KY (US); **Jerry McColgin**, Westfield, IN (US)

(73) Assignee: **DESA IP, LLC**, Miami, FL (US)

(**) Term: **14 Years**

(21) Appl. No.: **29/298,104**

(22) Filed: **Nov. 29, 2007**

Related U.S. Application Data

(63) Continuation of application No. 29/296,152, filed on Oct. 15, 2007.

(51) **LOC (8) Cl.** **12-02**

(52) **U.S. Cl.** **D34/12**

(58) **Field of Classification Search** D34/12-27;
280/47.12, 47.17, 47.19, 47.24, 47.26, 47.29,
280/795; 137/355.27
See application file for complete search history.

(56) **References Cited**

U.S. PATENT DOCUMENTS

1,116,789 A	11/1914	Bothwell	
1,679,359 A	9/1928	Jessen	
2,052,803 A *	9/1936	Schmoller	280/641
2,094,915 A	10/1937	Dawson	
2,154,800 A *	4/1939	St John Zumwinkel	280/641
2,191,100 A	2/1940	Starling	
2,261,514 A	11/1941	Dumogan	
2,410,881 A	11/1946	Hunter	
2,425,026 A	8/1947	Breese	
D149,411 S *	4/1948	Harley	D34/23
2,548,987 A	4/1951	Mayo	
2,686,516 A	8/1954	Yawman, Jr.	
2,744,516 A	5/1956	Hubbard	
2,758,590 A	8/1956	Besser	

2,780,218 A	2/1957	Allen	
2,811,962 A	11/1957	Pelsue et al.	
2,818,717 A	1/1958	Morris	
2,822,800 A	2/1958	Hines	
3,051,227 A	8/1962	Robson	
3,140,740 A	7/1964	Lag Reid et al.	
3,158,193 A	11/1964	Anderson	
3,174,477 A	3/1965	Wilson	
D200,768 S *	4/1965	Masoll	D34/12
3,176,728 A	4/1965	Baumann	
3,229,070 A	1/1966	Wells	
3,409,040 A	11/1968	Weston et al.	
3,503,379 A	3/1970	Kuhn et al.	
3,557,772 A	1/1971	Kofink	

(Continued)

FOREIGN PATENT DOCUMENTS

JP 55035876 3/1980

Primary Examiner—Cynthia E Ramirez

(74) *Attorney, Agent, or Firm*—John F. Salazar; Middleton Reutlinger

(57) **CLAIM**

The ornamental design for a carrier for a portable heater, as shown and described.

DESCRIPTION

FIG. 1 is a perspective view of the design for a carrier for portable heater;

FIG. 2 is a top view thereof;

FIG. 3 is a front view thereof;

FIG. 4 is a right side view thereof;

FIG. 5 is a left side view thereof;

FIG. 6 is a rear view thereof; and,

FIG. 7 is a bottom view thereof.

The broken lines shown on the drawings are for illustrative purposes only and form no part of the claimed design.

1 Claim, 7 Drawing Sheets

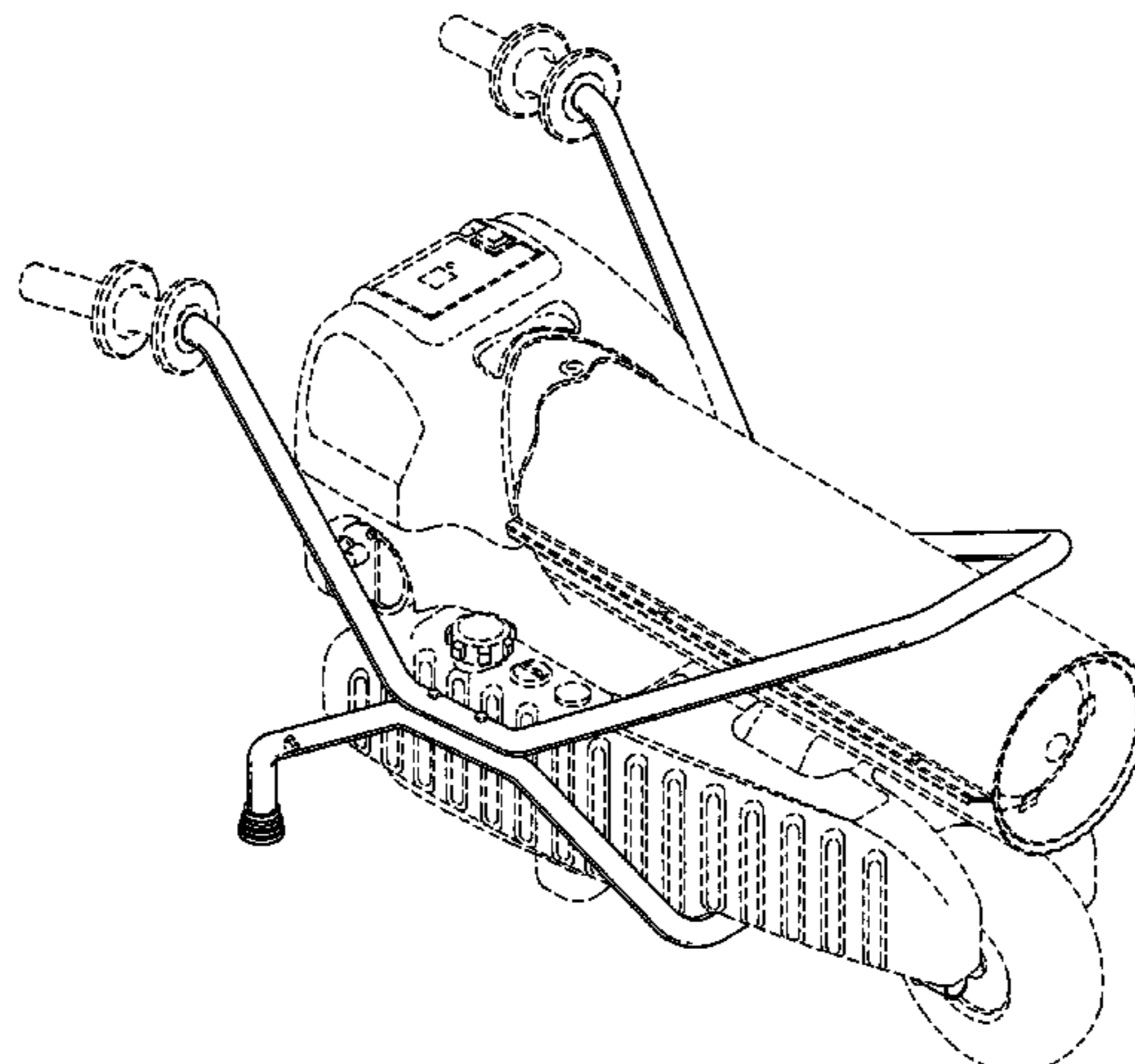

US D577,173 S

Page 2

U.S. PATENT DOCUMENTS					
		D370,194 S *	5/1996	Baechler et al.	D12/129
3,603,711 A	9/1971	5,516,282 A	5/1996	Somerville	
3,734,677 A	5/1973	5,540,213 A	7/1996	Shell et al.	
3,749,551 A	7/1973	5,766,003 A	6/1998	Vogelzang	
3,774,654 A	11/1973	5,775,315 A	7/1998	Baykal	
3,982,524 A	9/1976	5,848,585 A	12/1998	Long et al.	
4,005,976 A	2/1977	D423,170 S *	4/2000	Chan	D34/15
4,263,886 A	4/1981	6,065,466 A	5/2000	Baykal	
4,276,018 A	6/1981	6,142,141 A	11/2000	Long	
D265,518 S *	7/1982	D444,279 S *	6/2001	Kristiansen et al.	D34/12
4,340,362 A	7/1982	6,397,902 B1	6/2002	Murphy	
4,363,621 A	12/1982	D465,632 S *	11/2002	Koppes et al.	D34/17
4,537,232 A	8/1985	D468,952 S	1/2003	Graham et al.	
4,543,057 A	9/1985	6,595,200 B1	7/2003	Dai	
4,596,277 A	6/1986	6,619,281 B2	9/2003	Resmo et al.	
4,651,711 A	3/1987	6,648,635 B2	11/2003	Vandrak et al.	
4,653,552 A	3/1987	6,760,543 B1	7/2004	Orr et al.	
4,691,687 A	9/1987	6,843,244 B2	1/2005	McCalley et al.	
4,788,963 A	12/1988	D501,974 S *	2/2005	Lawson et al.	D34/27
4,848,313 A	7/1989	D502,793 S *	3/2005	Porter	D34/12
4,850,853 A	7/1989	6,880,549 B2	4/2005	Topp	
4,941,452 A	7/1990	D509,938 S *	9/2005	Belmont et al.	D34/12
5,131,670 A *	7/1992	7,210,691 B2 *	5/2007	Puczkowski	280/79.5
5,445,196 A	8/1995				

* cited by examiner

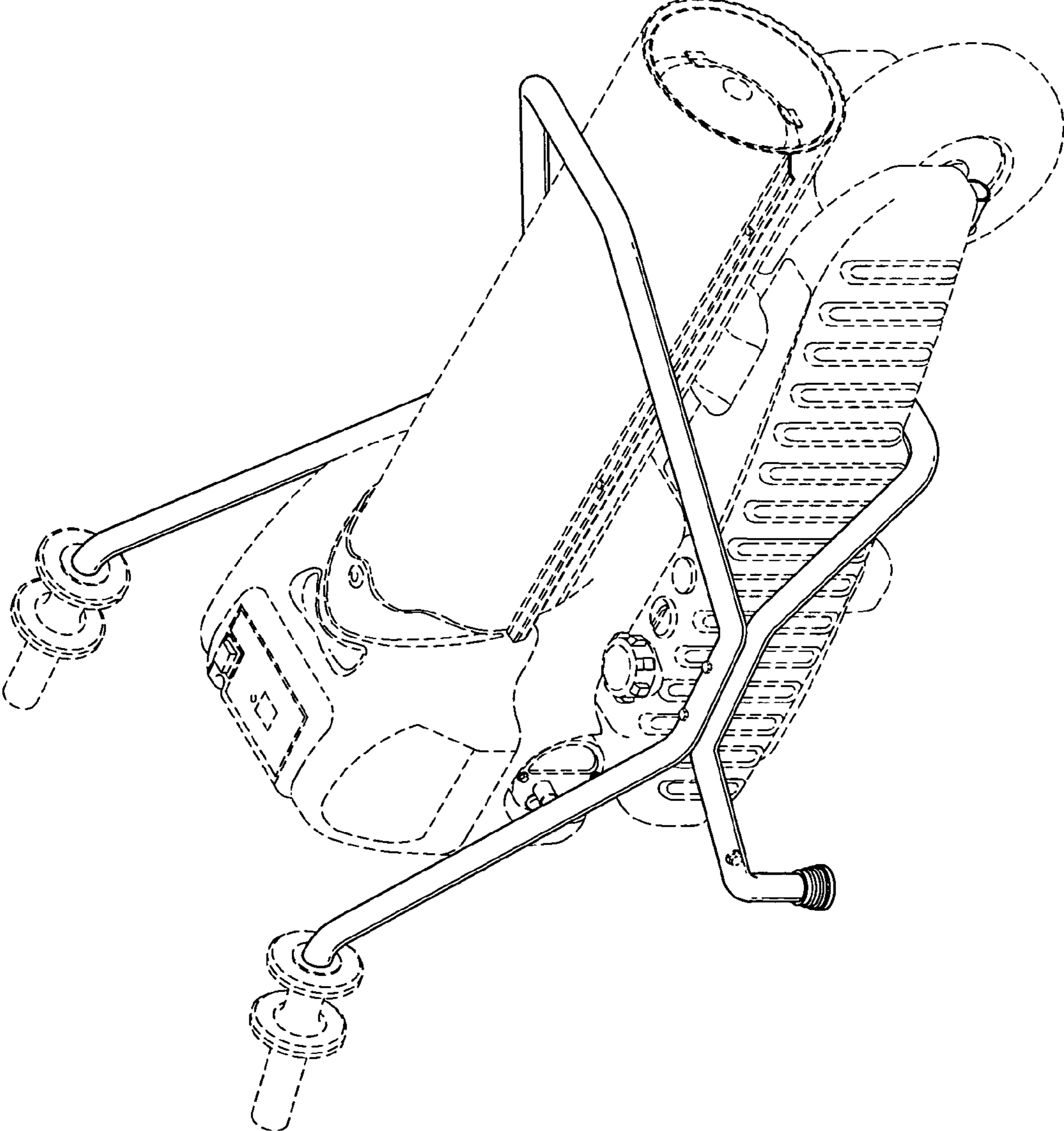

FIG. 1

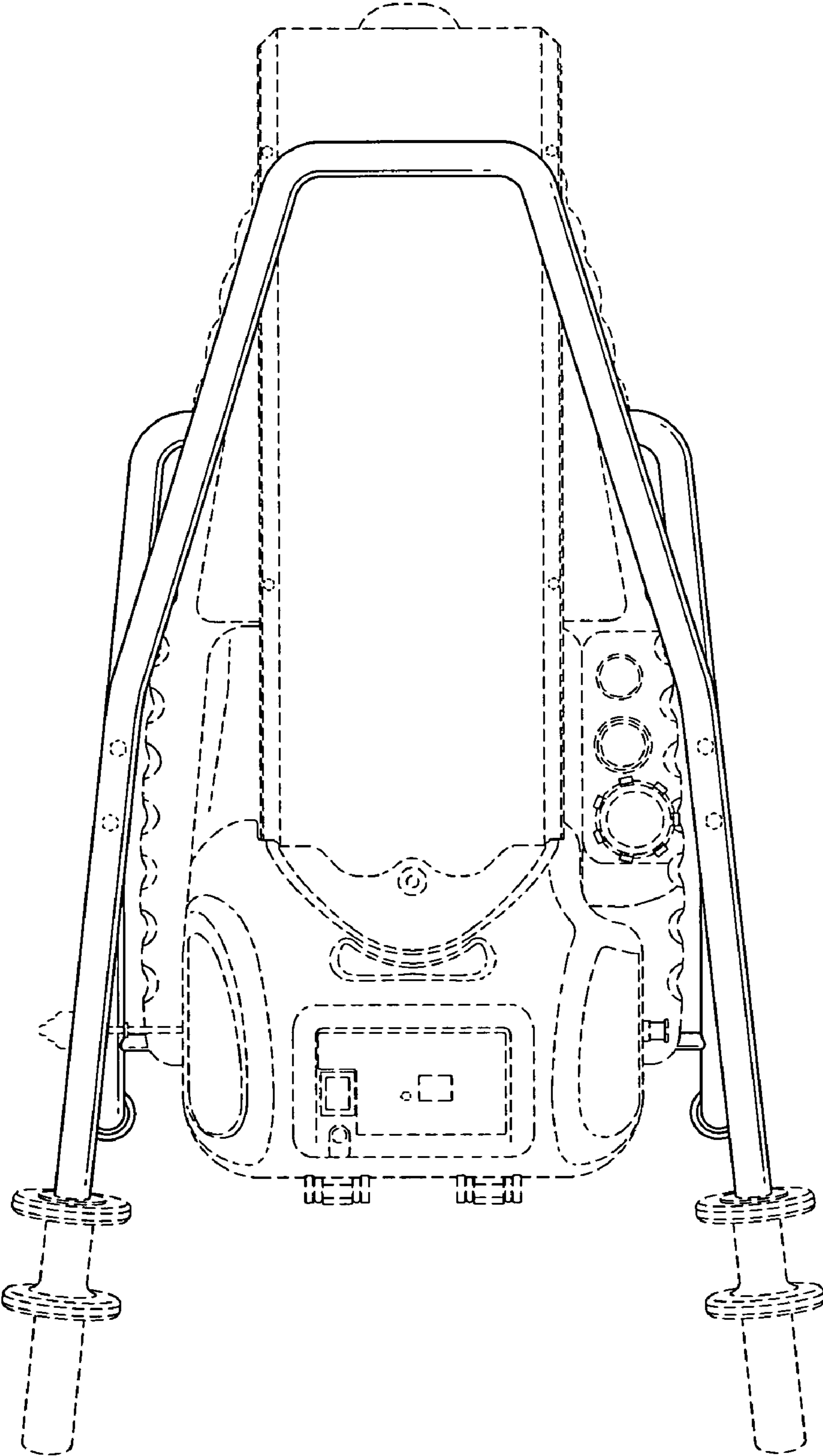

FIG. 2

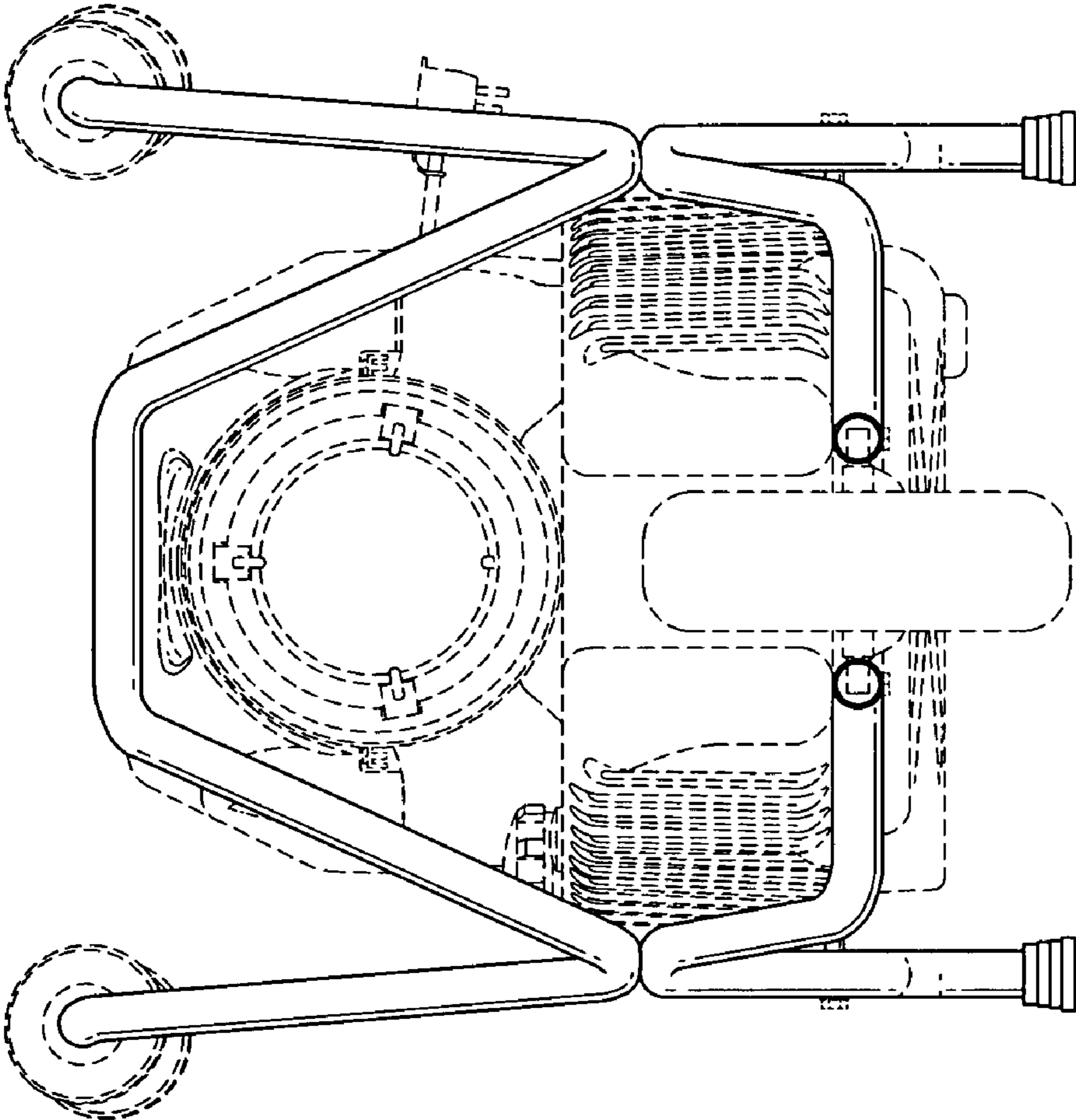

FIG. 3

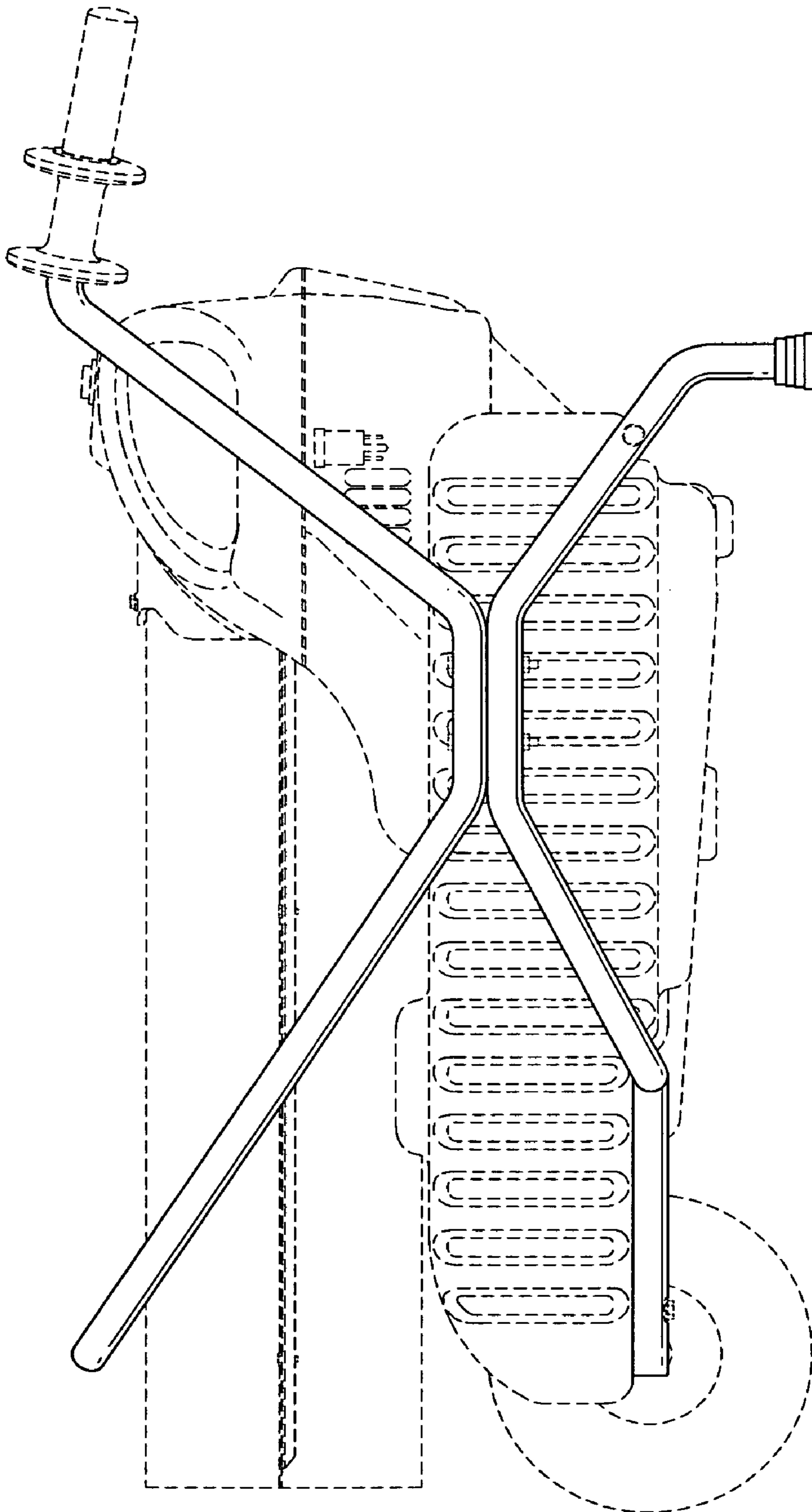

FIG. 4

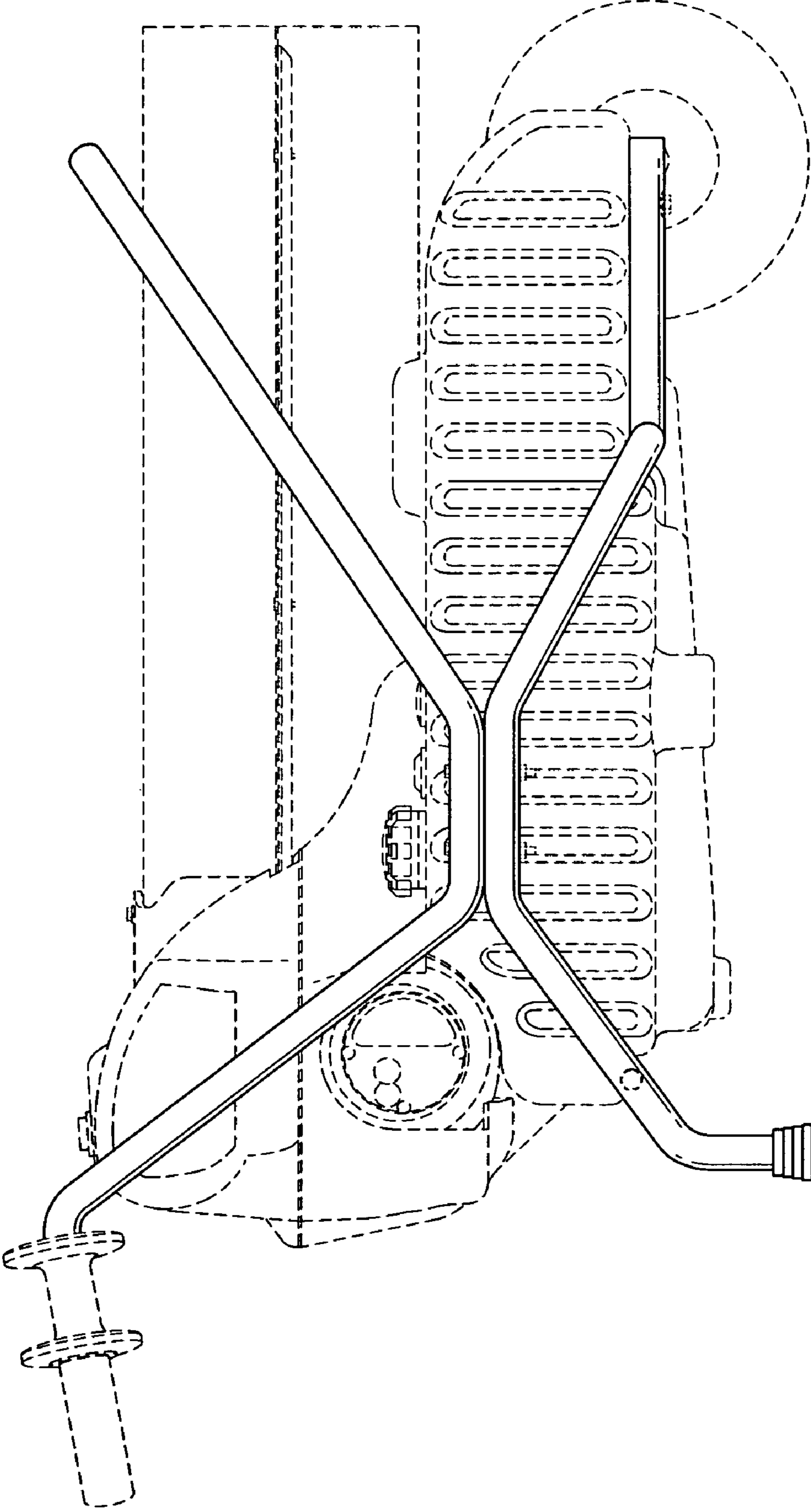

FIG. 5

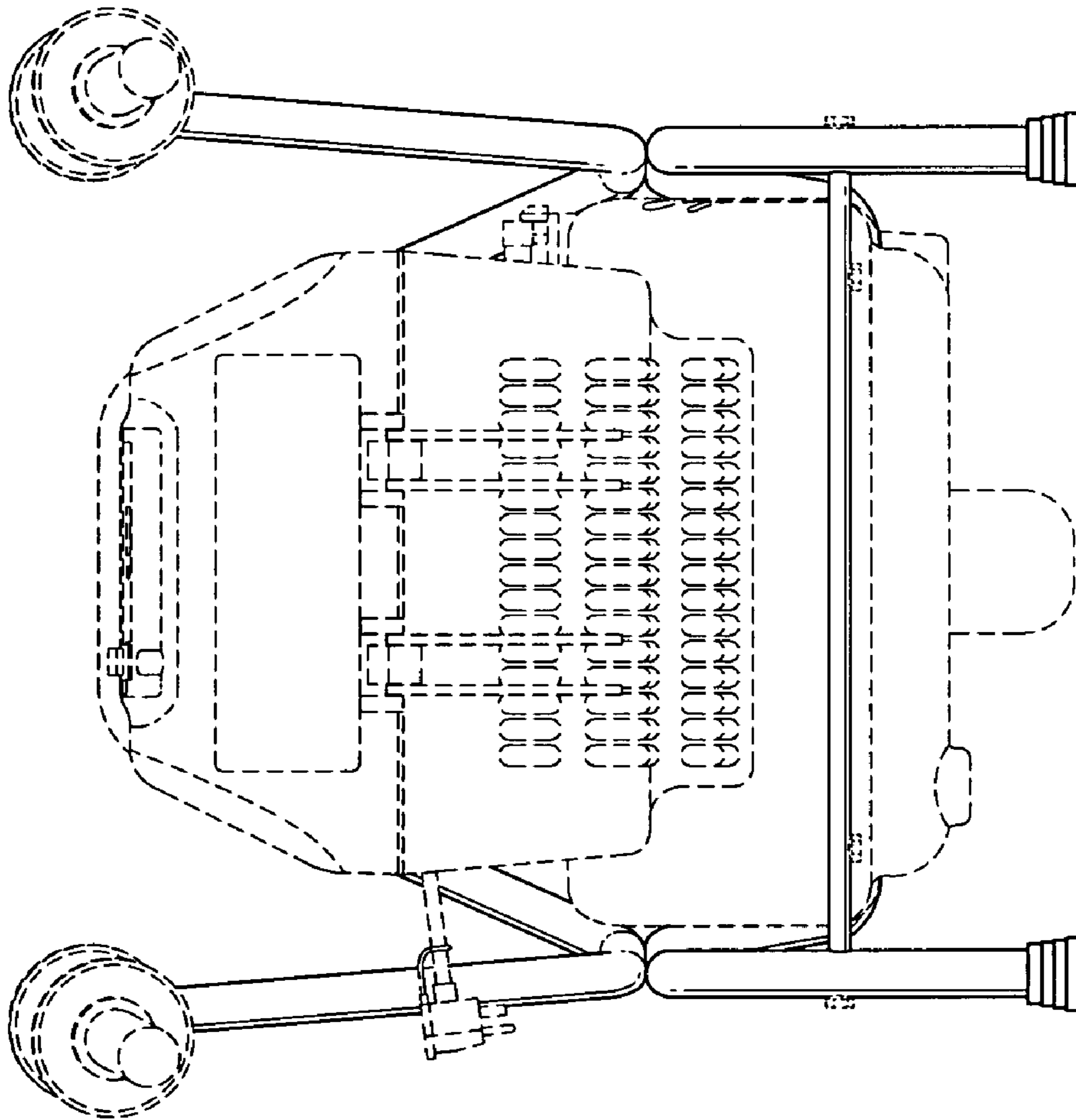

FIG. 6

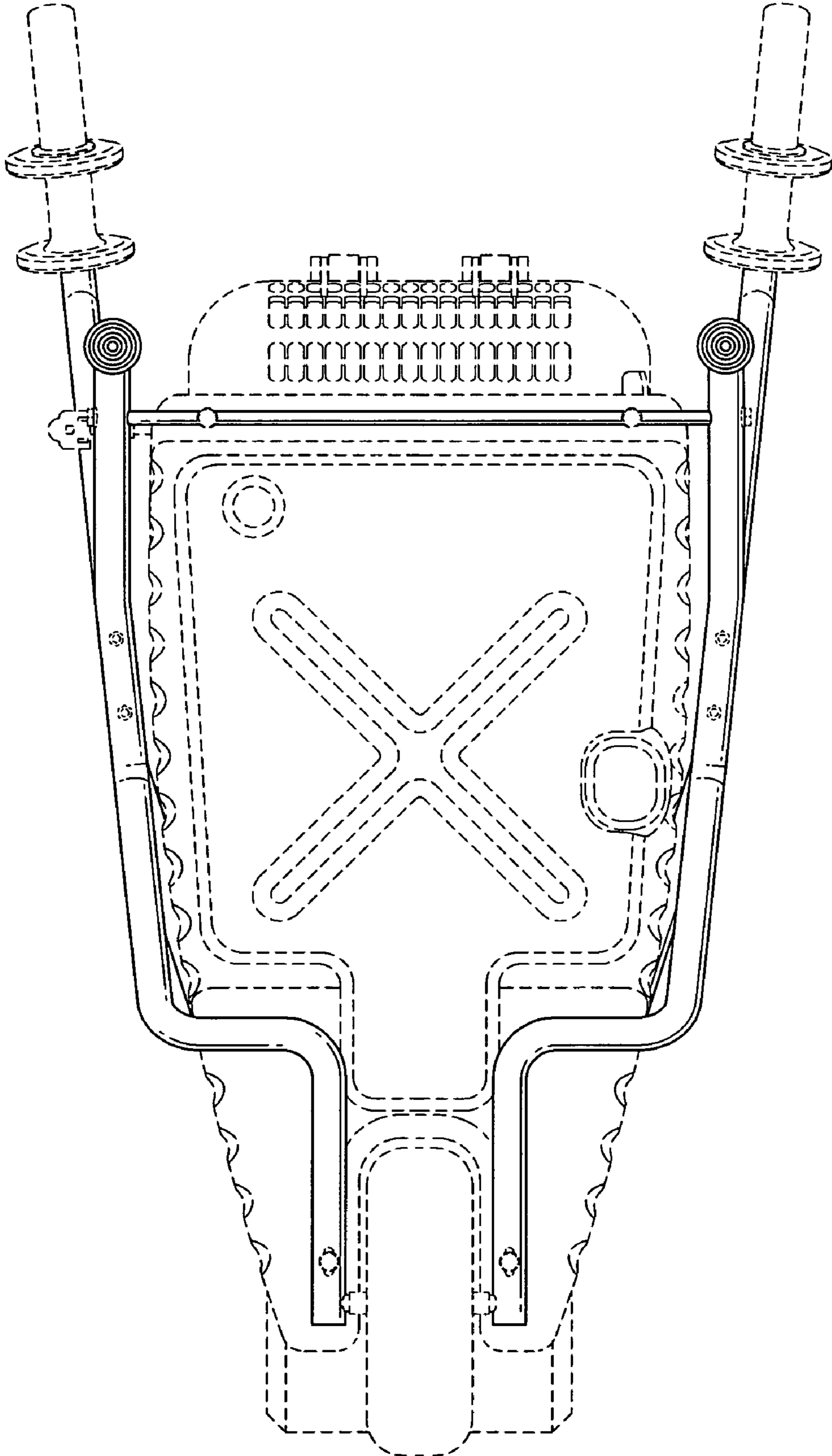

FIG. 7