

US00D577137S

(12) **United States Design Patent**  
**Lamm**

(10) **Patent No.:** **US D577,137 S**

(45) **Date of Patent:** **\*\* Sep. 16, 2008**

(54) **VEHICLE TAILLIGHT**

(75) Inventor: **Stefan Lamm**, Köln (DE)

(73) Assignee: **Ford Global Technologies, LLC**,  
Dearborn, MI (US)

(\*\*) Term: **14 Years**

(21) Appl. No.: **29/298,841**

(22) Filed: **Dec. 13, 2007**

(51) **LOC (8) Cl.** ..... **26-06**

(52) **U.S. Cl.** ..... **D26/28**

(58) **Field of Classification Search** ..... D26/28-36;  
362/459-468, 475-478, 485-487

See application file for complete search history.

(56) **References Cited**

**U.S. PATENT DOCUMENTS**

D498,013 S	*	11/2004	Pfeiffer	.....	D26/28
D503,487 S	*	3/2005	Papke et al.	.....	D26/28
D506,277 S	*	6/2005	Ito	.....	D26/28
D552,273 S	*	10/2007	Gresens et al.	.....	D26/28
D553,268 S	*	10/2007	Pfeiffer	.....	D26/28

**OTHER PUBLICATIONS**

<http://www.zercustoms.com/photos/Ford-Verve.html>, prior to Dec. 13, 2007.

\* cited by examiner

*Primary Examiner*—Marcus A Jackson

(74) *Attorney, Agent, or Firm*—Damian Porcari

(57) **CLAIM**

The ornamental design for a vehicle taillight, as shown and described.

**DESCRIPTION**

FIG. 1 is a front view of a right vehicle taillight, as seen from the rear of a vehicle (the left vehicle taillight being a mirror of the right and is not illustrated);

FIG. 2 is a left side elevational view of the vehicle taillight;

FIG. 3 is a right side elevational view of the vehicle taillight;

FIG. 4 is top plan view of the vehicle taillight;

FIG. 5 is a bottom plan view of the vehicle taillight; and,

FIG. 6 is a front elevational view of the vehicle taillight.

The vehicle taillight is styled independently of adjacent vehicle panels. To the extent that any feature lines are illustrated, they are intended to illustrate the crest and valley of the feature and are not necessarily sharp bends in the part. Shading is used to illustrate the curvature of the part and not color. Views are orthogonal projections unless otherwise noted. The various views are not necessarily to scale in order to better illustrate the design.

**1 Claim, 6 Drawing Sheets**

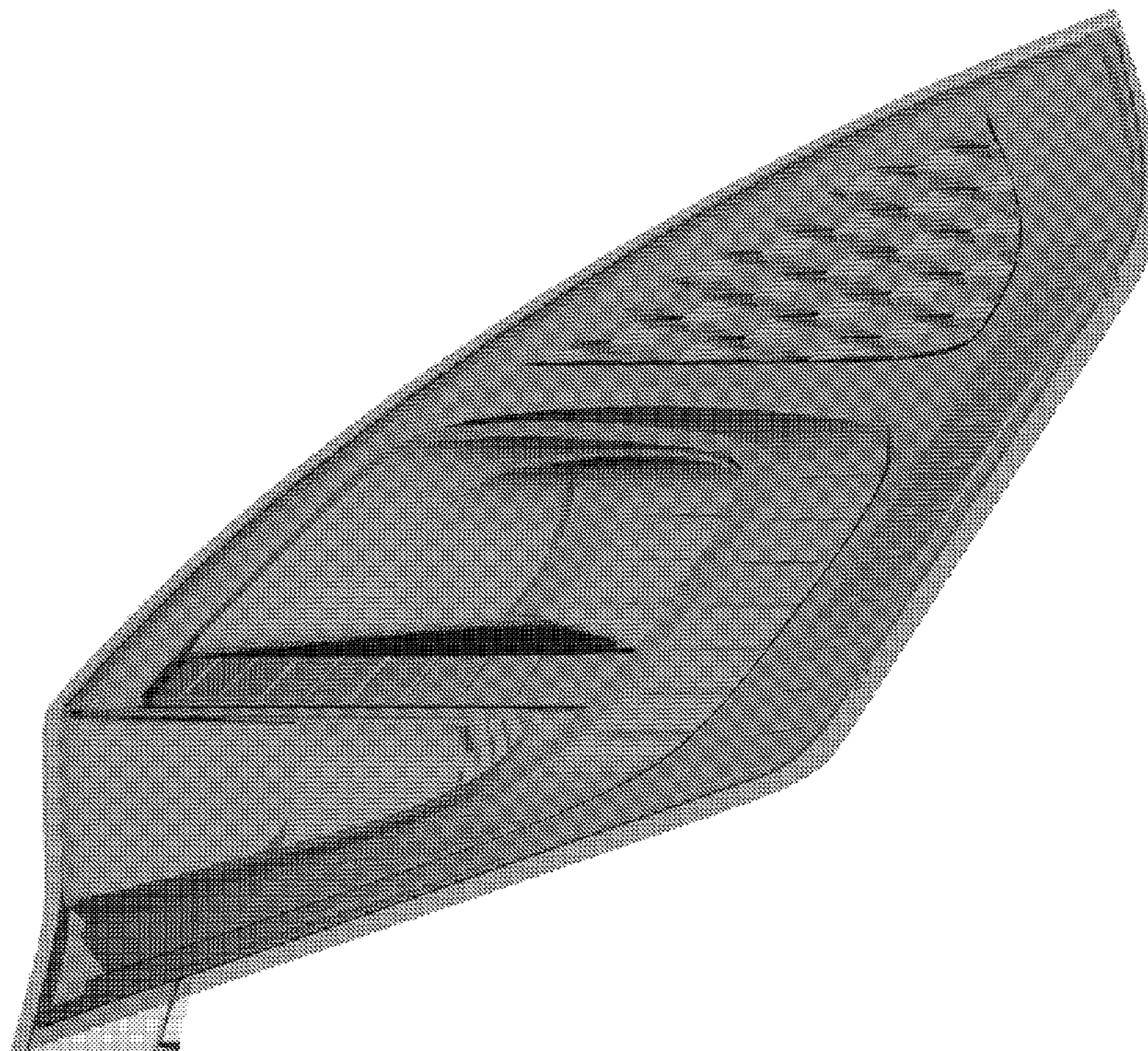

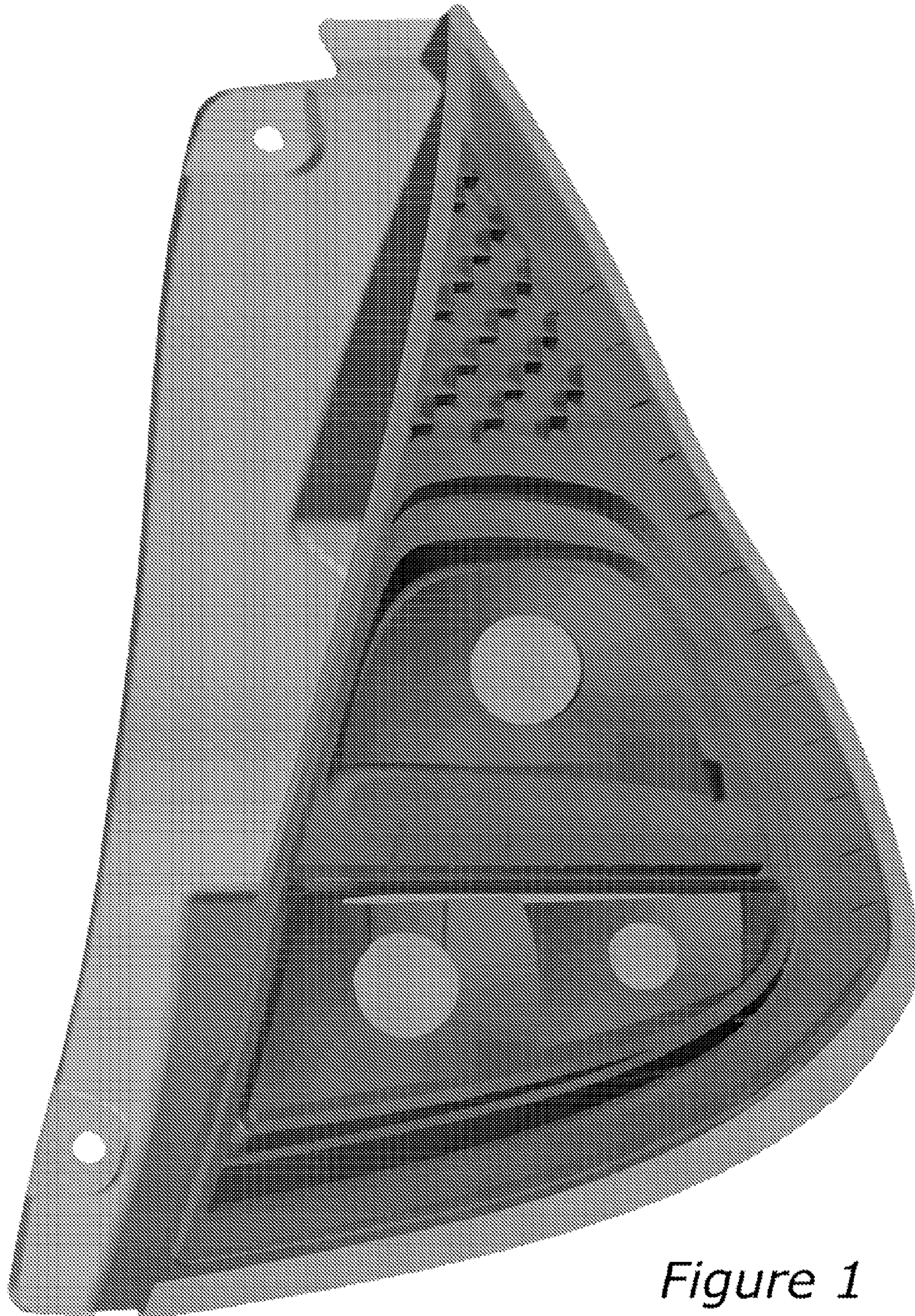

Figure 1

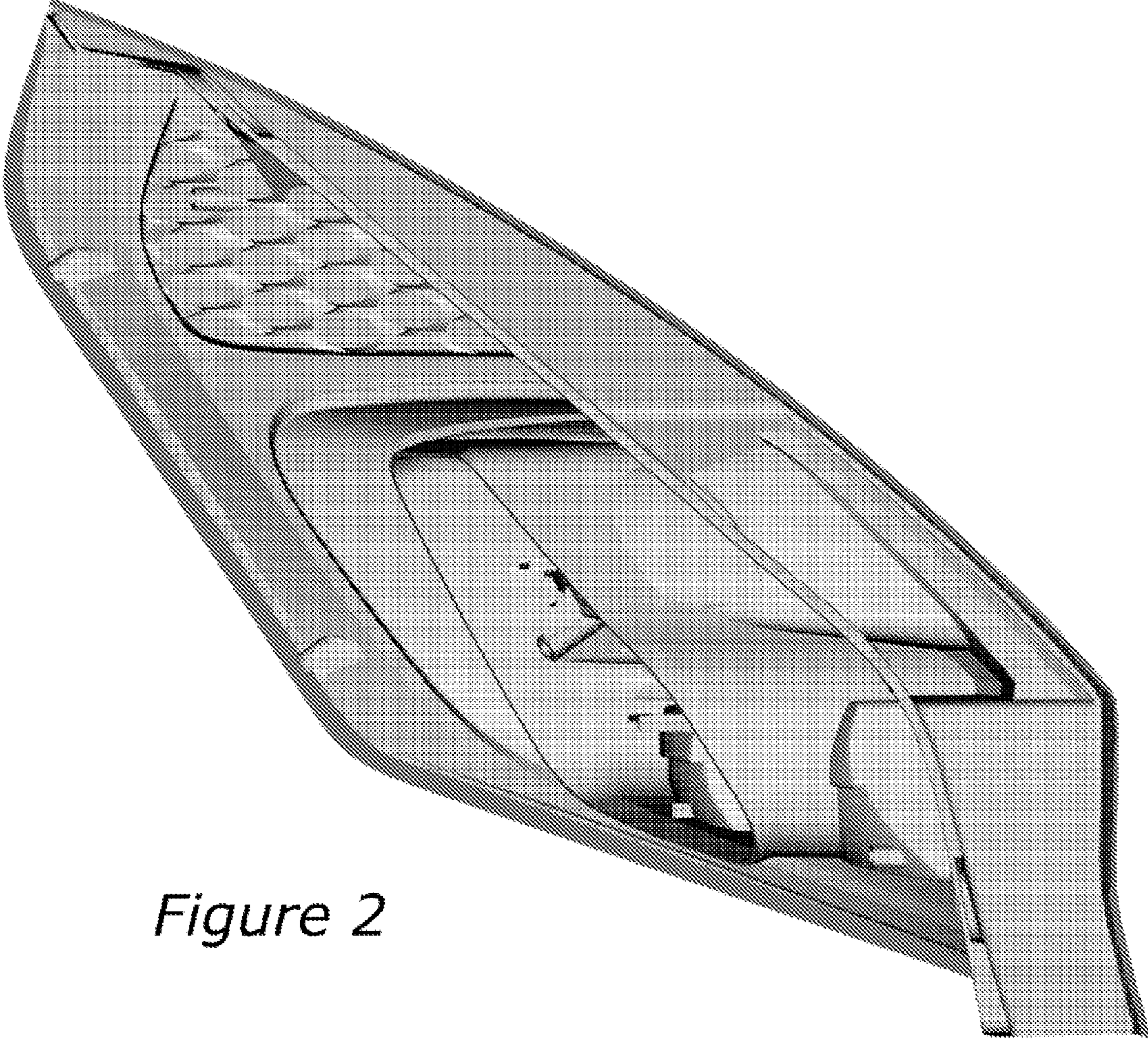
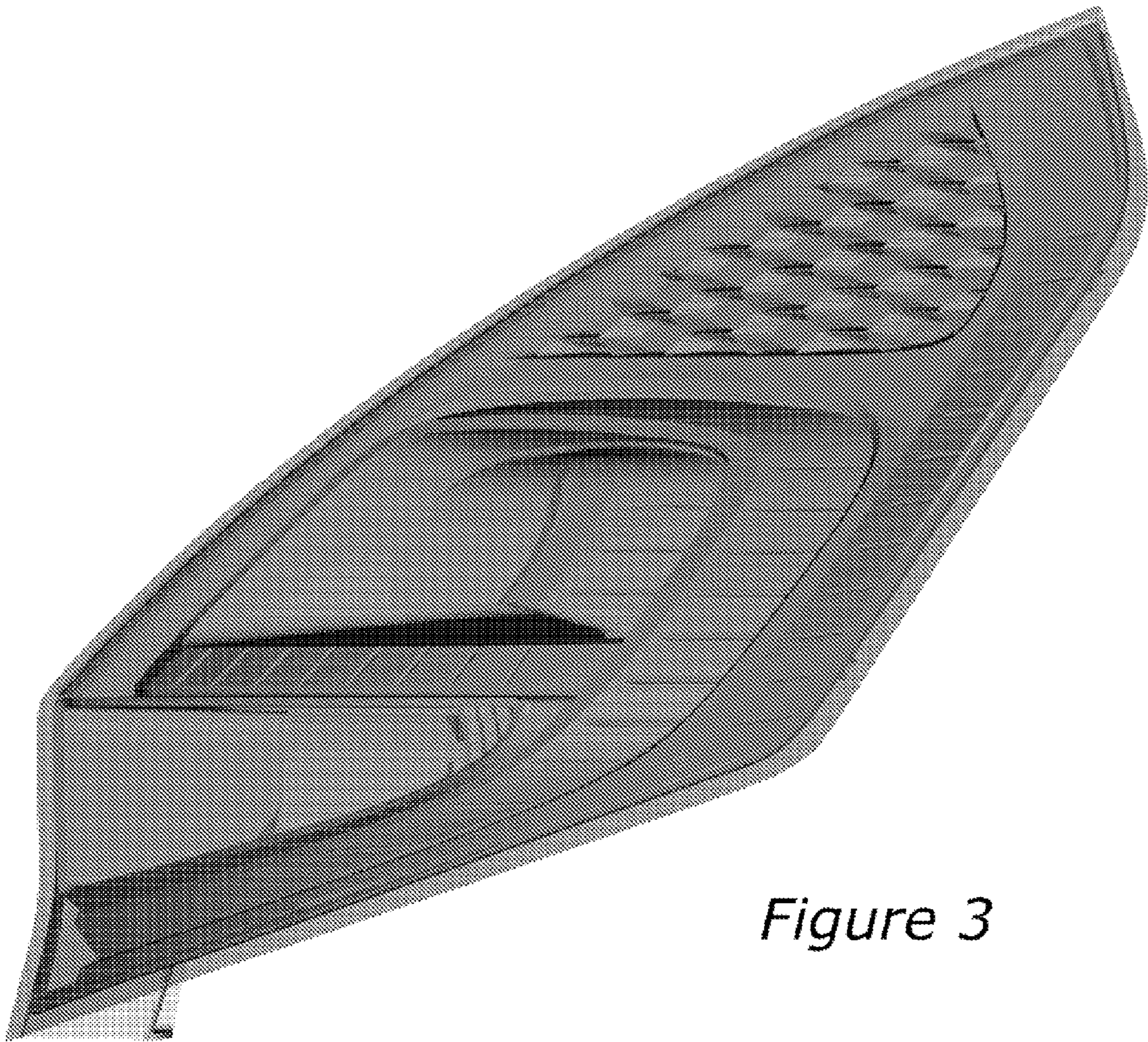
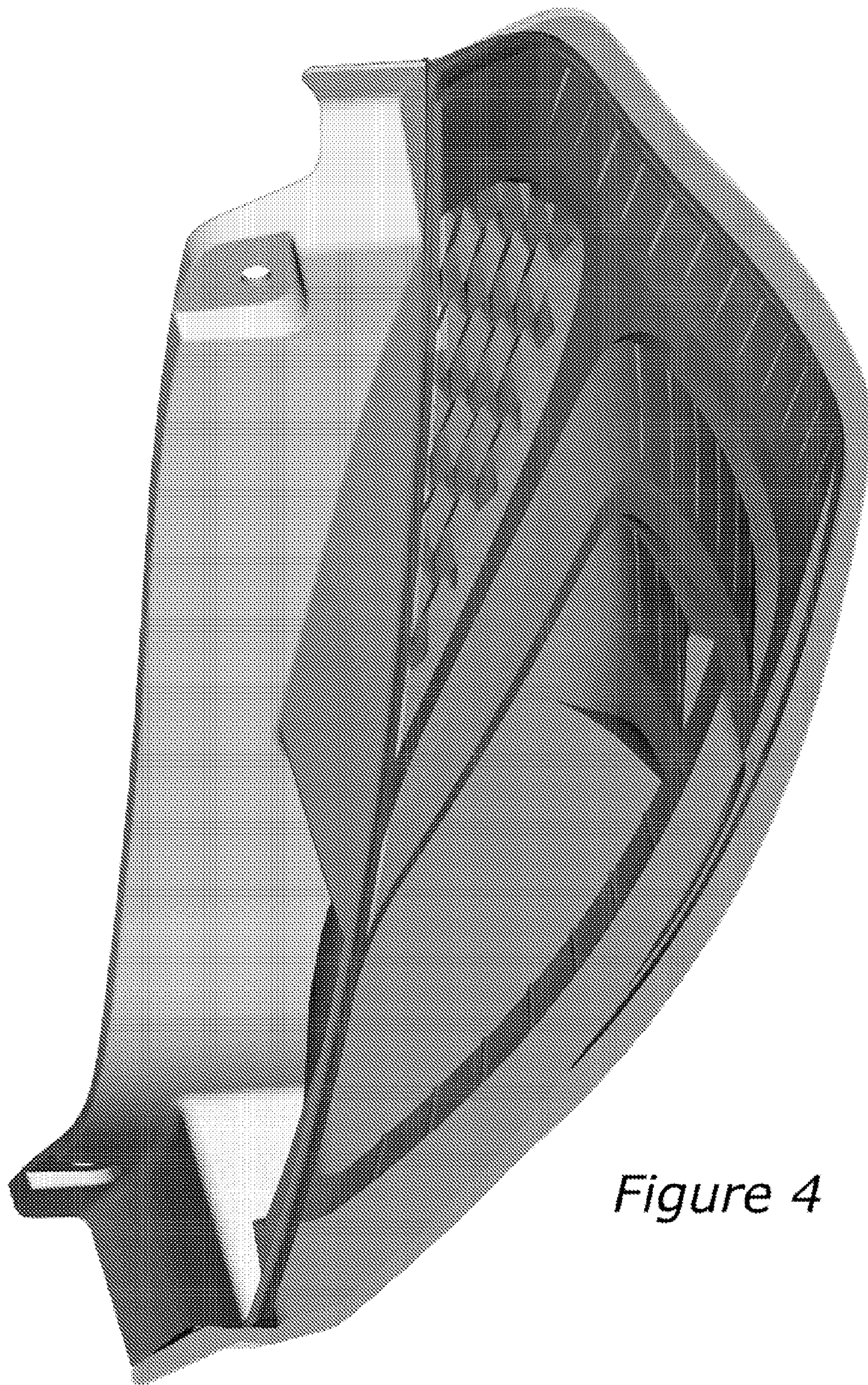

Figure 2



*Figure 3*



*Figure 4*

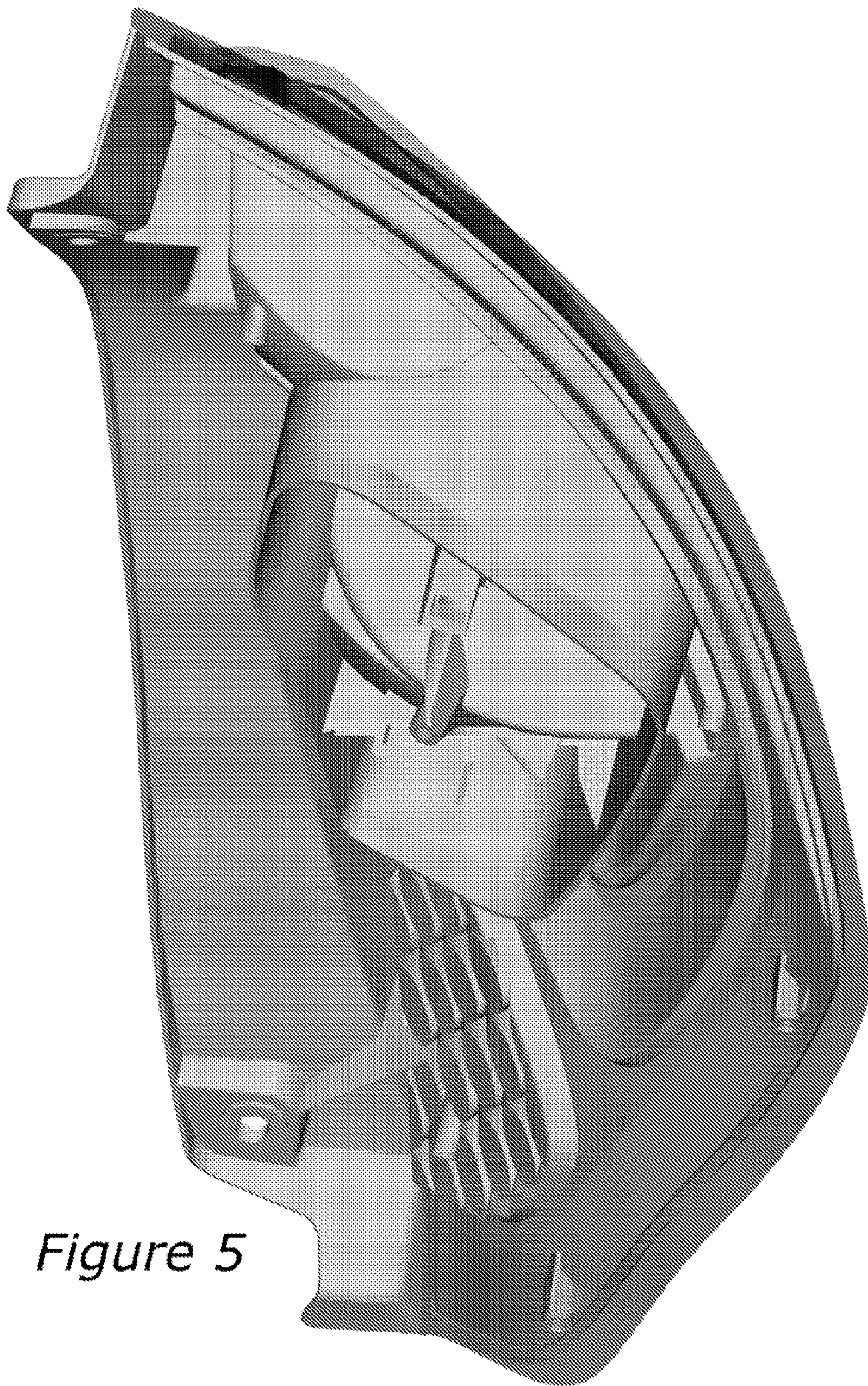

*Figure 5*

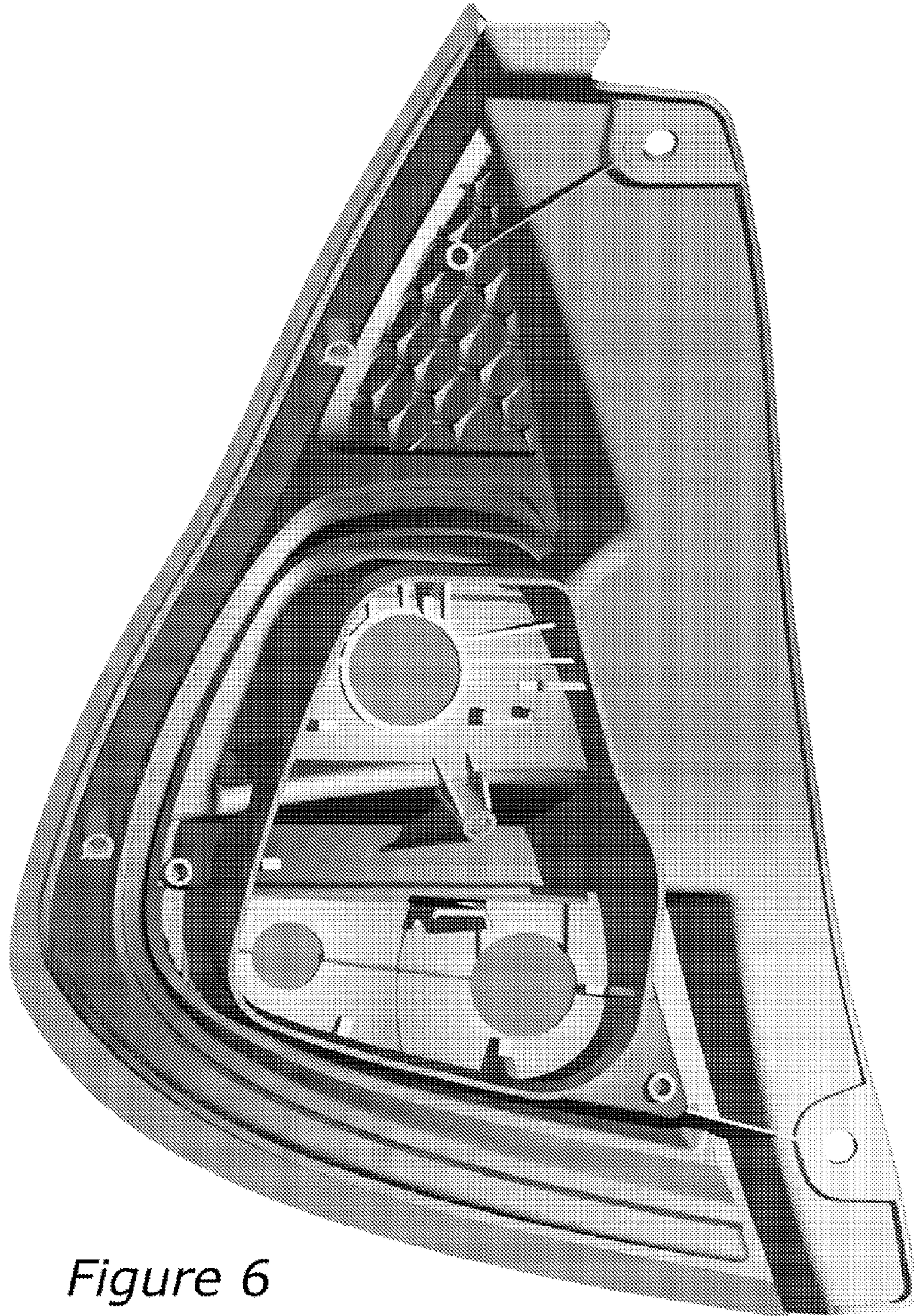

Figure 6