



US00D576642S

(12) **United States Design Patent**
Steinfels et al.

(10) **Patent No.:** **US D576,642 S**
(45) **Date of Patent:** **** Sep. 9, 2008**

(54) **HAND PORTABLE AIR COMPRESSOR**

(75) Inventors: **Craig R. Steinfels**, Jackson, TN (US);
Dustin M. Lee, Fairborn, OH (US)

(73) Assignee: **Black & Decker Inc.**, Newark, DE (US)

(**) Term: **14 Years**

(21) Appl. No.: **29/276,772**

(22) Filed: **Feb. 5, 2007**

(51) **LOC (8) Cl.** **15-02**

(52) **U.S. Cl.** **D15/9**

(58) **Field of Classification Search** D15/7-9;
D23/231, 232; 417/410.1, 359, 415-416,
417/234, 321, 265, 405

See application file for complete search history.

(56) **References Cited**

U.S. PATENT DOCUMENTS

D277,675 S	2/1985	Hung	
D316,098 S *	4/1991	Kille	D15/7
D332,453 S	1/1993	Doolittle et al.	
D340,726 S *	10/1993	Wang	D15/7
D344,735 S *	3/1994	Ohman	D15/7
D352,295 S	11/1994	Morgan	
5,503,295 A	4/1996	Kotarba et al.	
D375,962 S	11/1996	Wong	
D394,440 S	5/1998	Chen	
D418,522 S	1/2000	Angel	
D460,166 S	7/2002	Wang	
D479,248 S	9/2003	Gist et al.	
6,655,925 B1	12/2003	Robenalt et al.	
6,742,995 B1	6/2004	Wood et al.	
D499,117 S	11/2004	Leasure et al.	
D507,799 S	7/2005	Chen	
6,923,364 B2	8/2005	Burkholder et al.	
6,923,627 B1	8/2005	Wood et al.	
6,942,464 B2	9/2005	Brashears et al.	
6,991,437 B2	1/2006	Cherry et al.	
6,994,528 B2	2/2006	Brashears et al.	
6,994,529 B2	2/2006	Downes	
D519,125 S *	4/2006	Burford et al.	D15/7

D528,131 S *	9/2006	Wu	D15/9
D541,822 S	5/2007	Wang	
D541,823 S	5/2007	Wang	
2004/0047744 A1	3/2004	Burkholder et al.	
2004/0047745 A1	3/2004	Burkholder et al.	
2006/0067836 A1	3/2006	Smith et al.	
2006/0104830 A1	5/2006	Fields	
2006/0104834 A1	5/2006	Stilwell	
2006/0245937 A1	11/2006	Goodwin et al.	

OTHER PUBLICATIONS

Bostitch - Trim Air Model CAP1516.
Bostitch - Oil-Free Model CAP2060P.
Harbor Freight - Model 38898.
Harbor Freight - Model 94291.
Hitachi - Model EC79.
Huskey - Model H1506F.
Huskey - Model Y1010.
Porter Cable - Model CF26001.
Rol-Air - Model P2002 HPV5.
Rol-Air - Model GD 4000 PV 5H.

* cited by examiner

Primary Examiner—R. Seifert

(74) *Attorney, Agent, or Firm*—Michael P. Leary; Adan Ayala

(57) **CLAIM**

The ornamental design for a hand portable air compressor, as shown and described.

DESCRIPTION

FIG. 1 is a right/front perspective view of a hand portable air compressor showing our new design.

FIG. 2 is a front view thereof.

FIG. 3 is a rear view thereof.

FIG. 4 is a left view thereof.

FIG. 5 is a right side view thereof.

FIG. 6 is a top side view thereof; and,

FIG. 7 is a bottom view thereof.

1 Claim, 6 Drawing Sheets

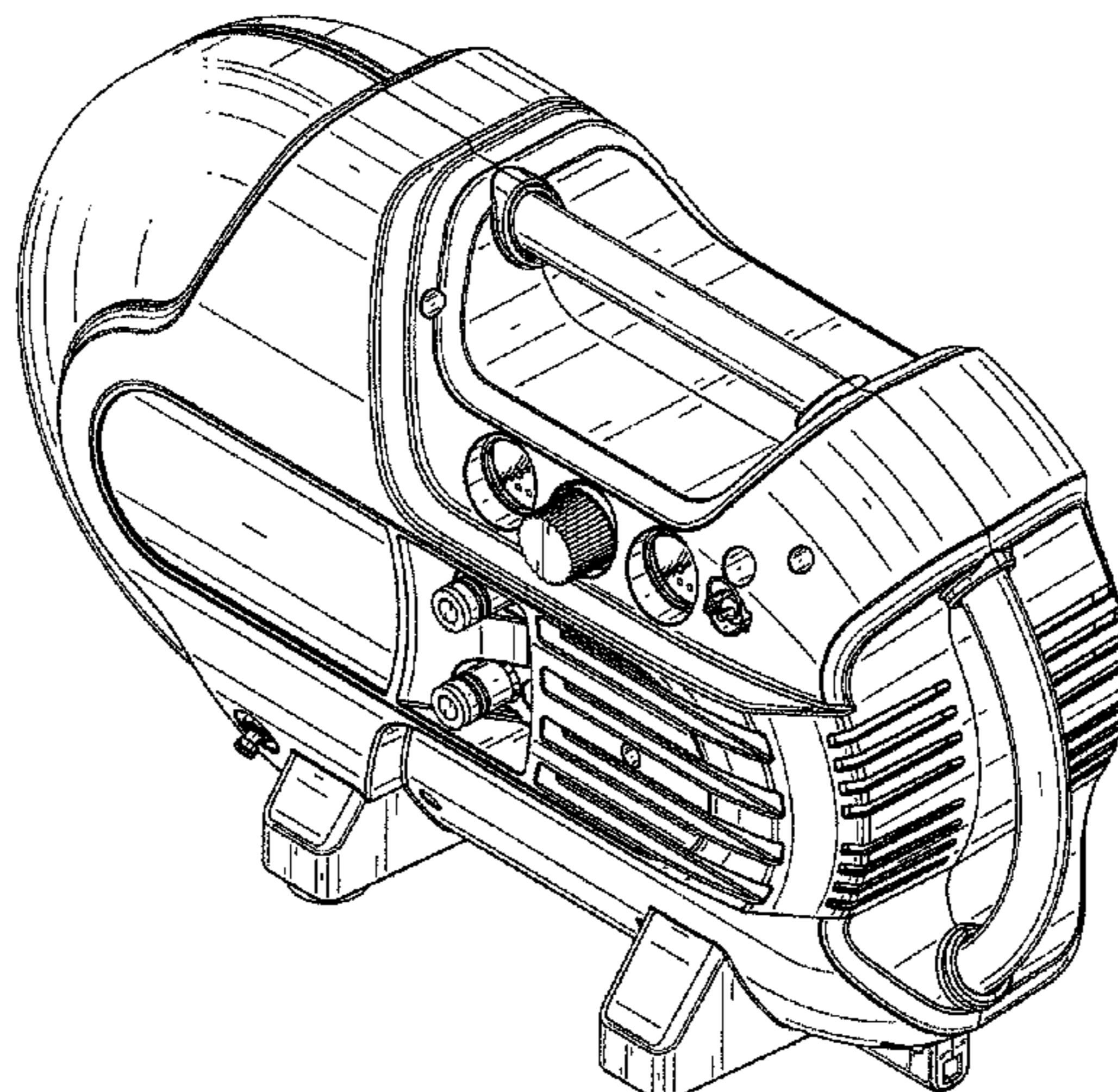

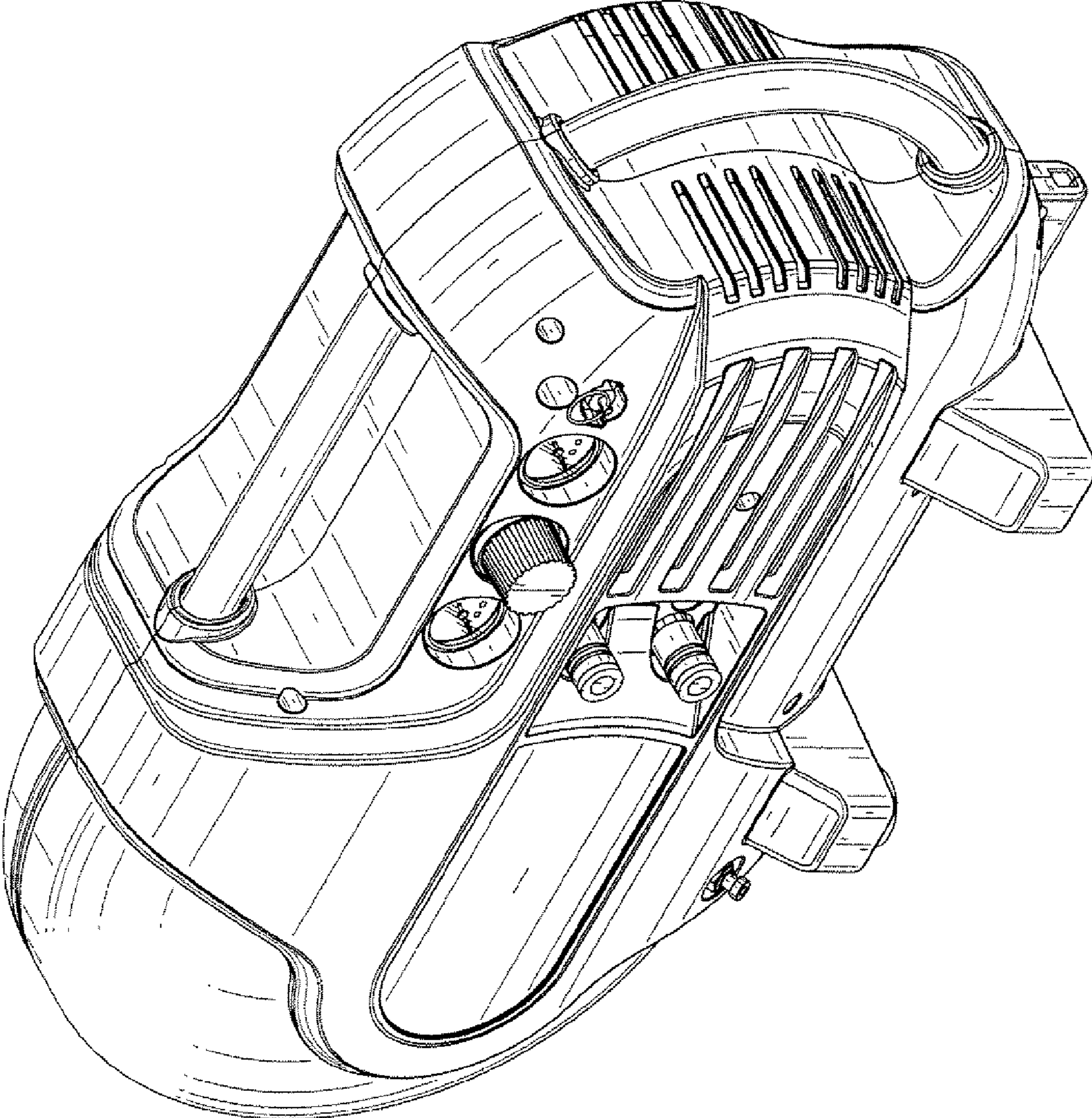

FIG. 1

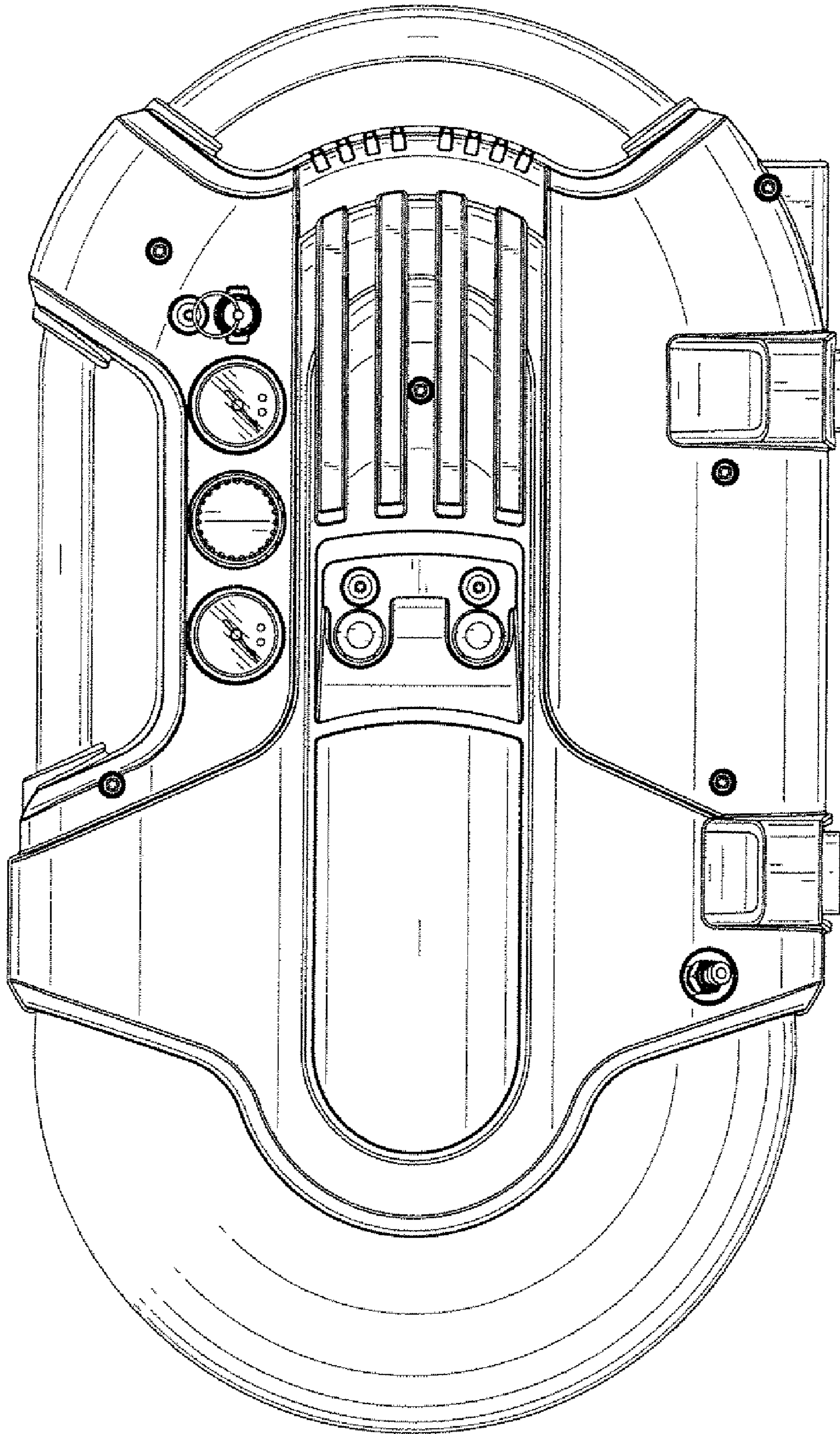

FIG. 2

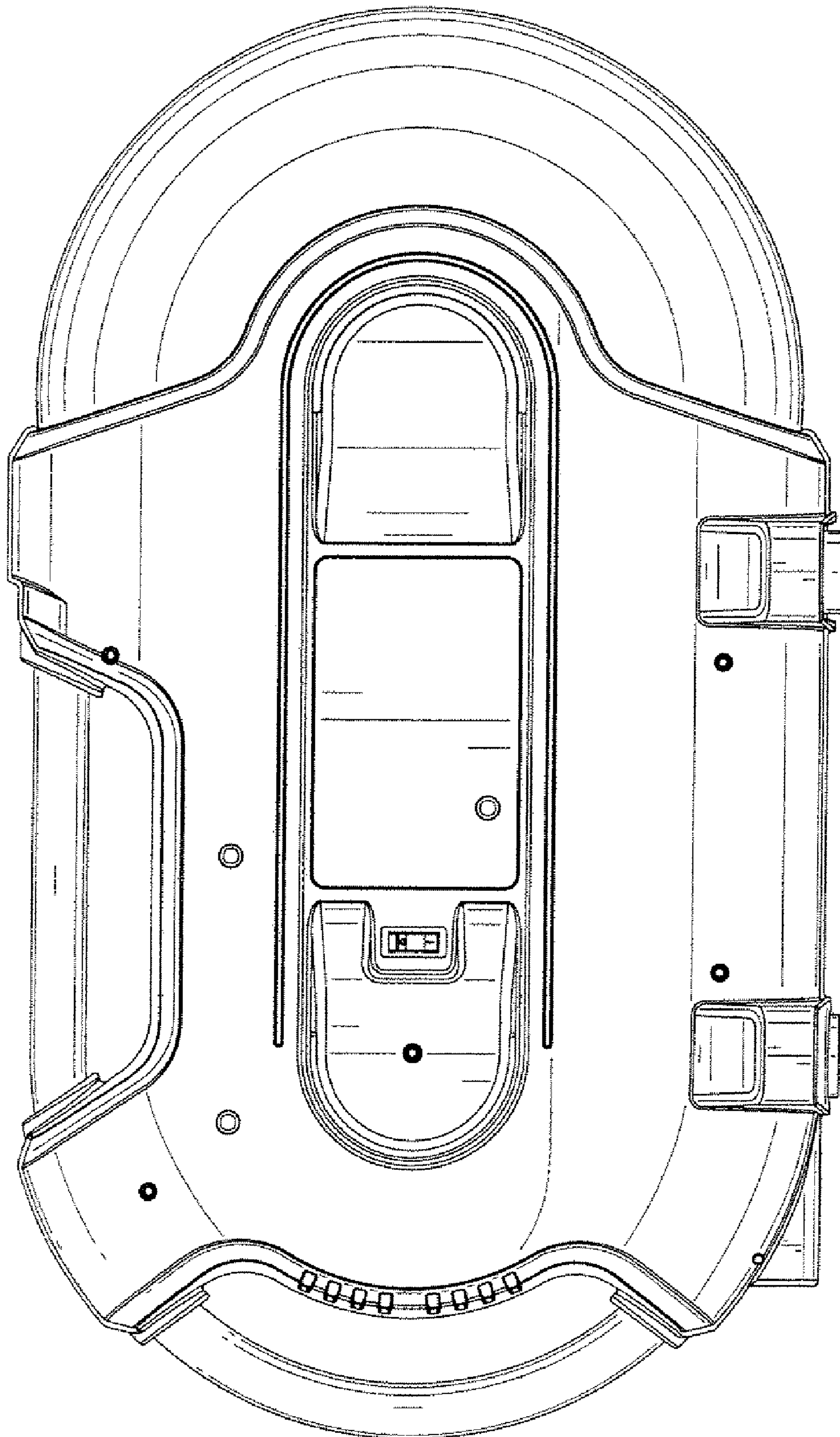

FIG. 3

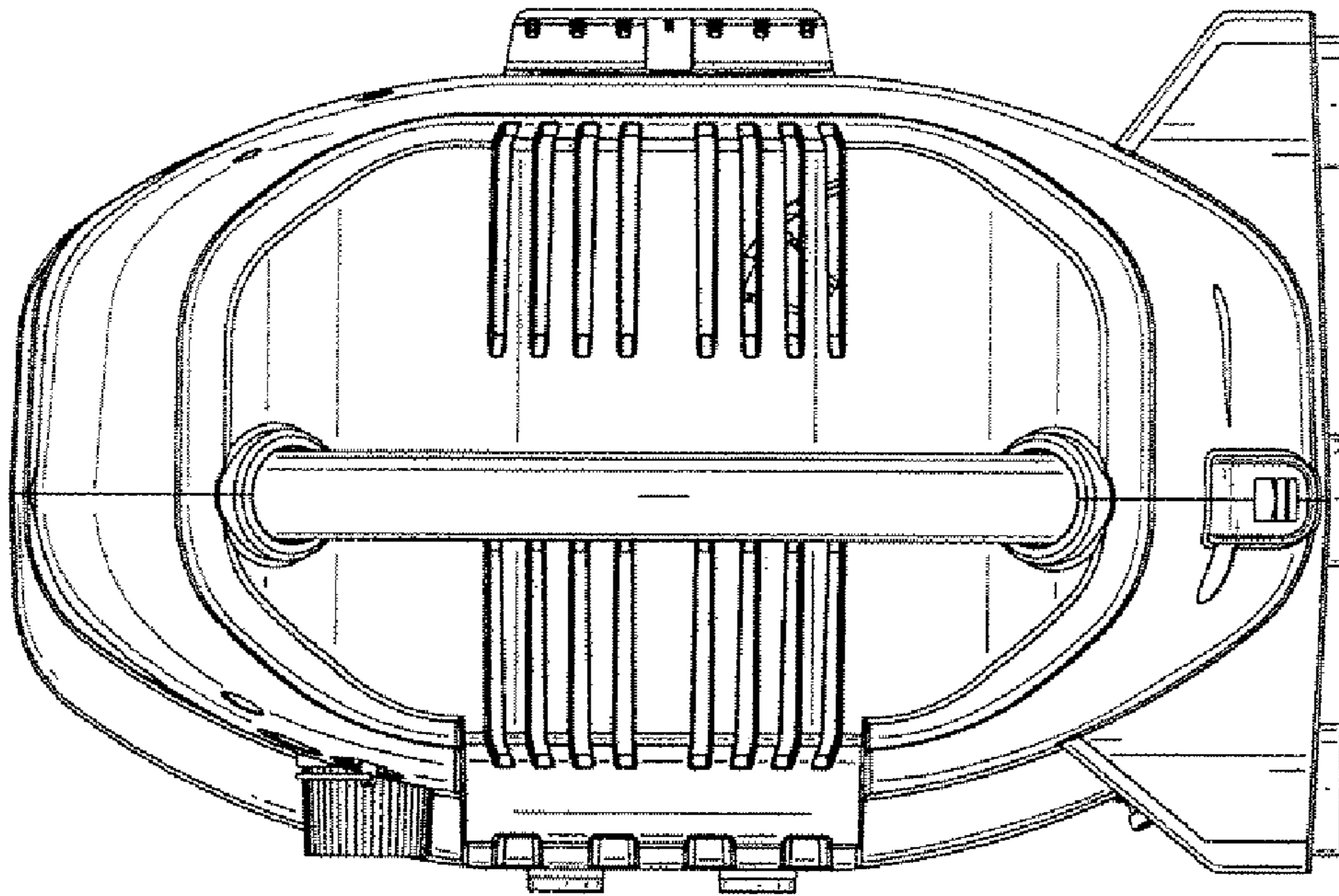

FIG. 5

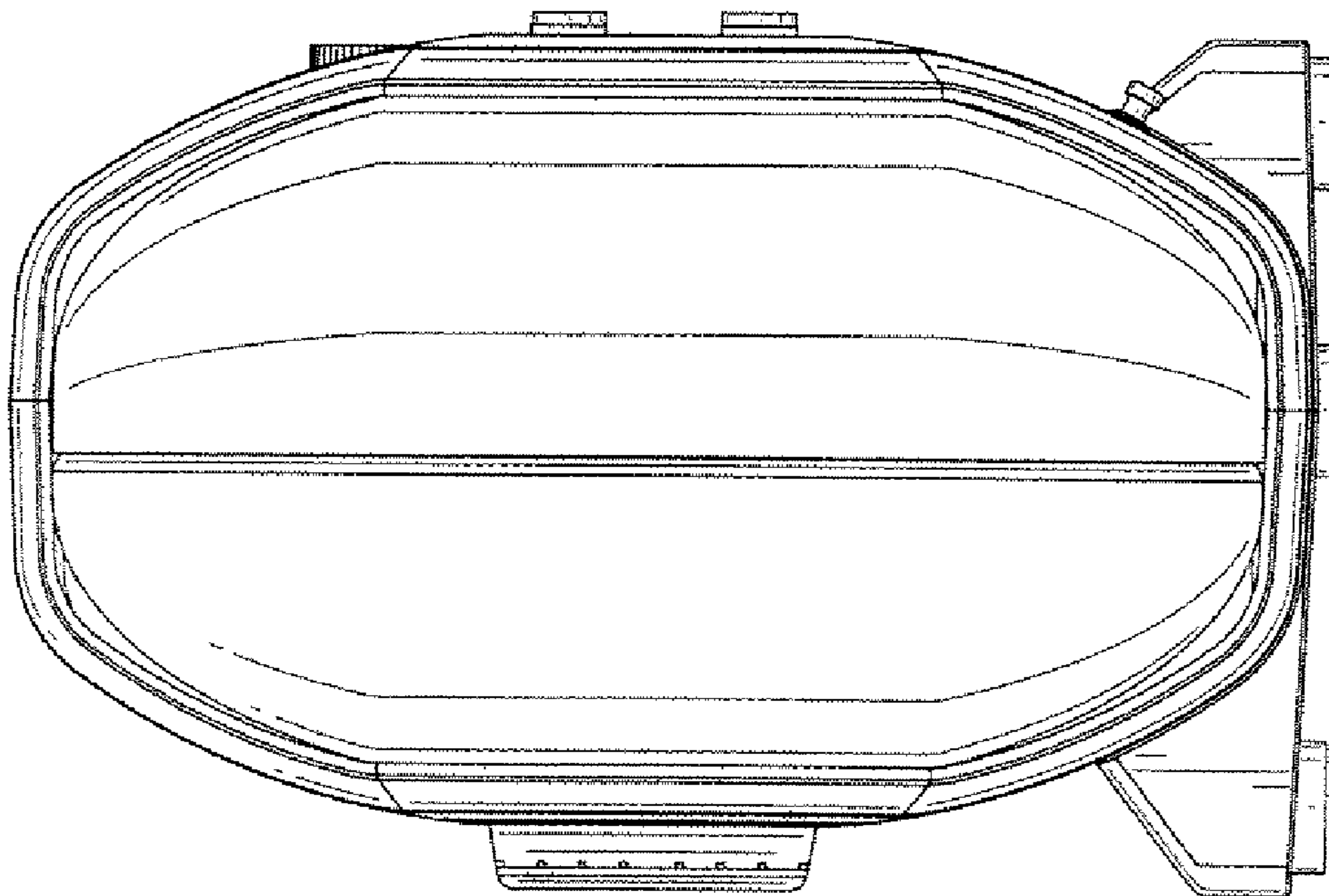

FIG. 4

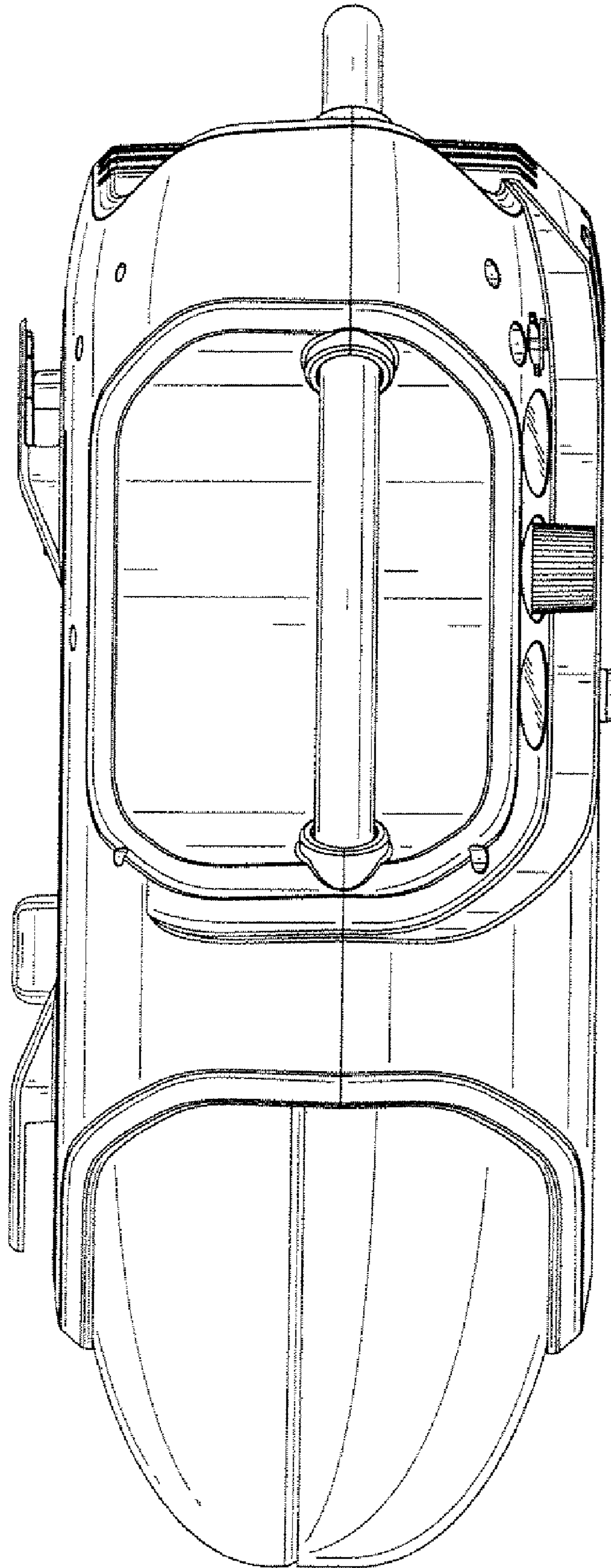

FIG. 6

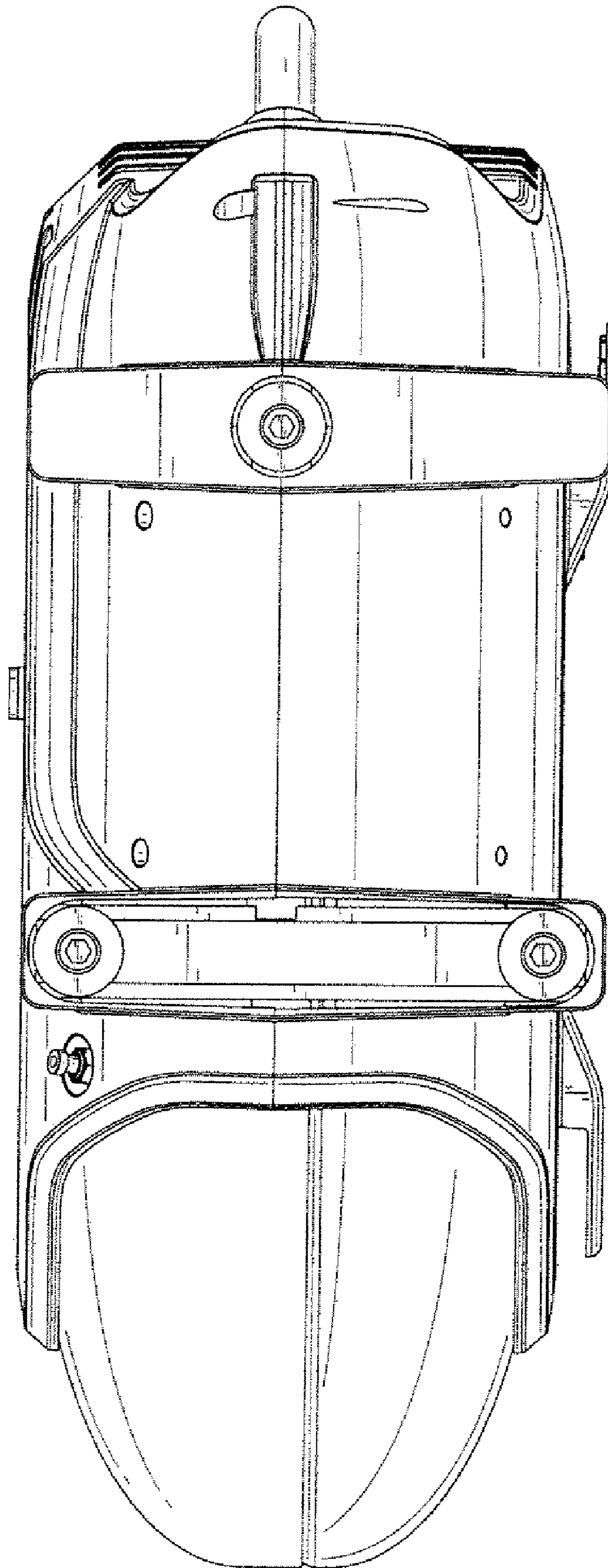

FIG. 7