



US00D576085S

(12) **United States Design Patent**
Devlin

(10) **Patent No.:** **US D576,085 S**
(45) **Date of Patent:** **** Sep. 2, 2008**

(54) **BUMPER HITCH WOBBLE REDUCTION DEVICE**

(76) Inventor: **Gary W. Devlin**, 807 Koehler Ave., Sherwood, AR (US) 72120

(**) Term: **14 Years**

(21) Appl. No.: **29/276,952**

(22) Filed: **Feb. 9, 2007**

(51) **LOC (8) Cl.** **11-01**

(52) **U.S. Cl.** **D12/162**

(58) **Field of Classification Search** D12/106,
D12/162, 400, 401, 403; 280/495, 507, 511,
280/727, 769; 40/200, 204, 205, 209, 211,
40/575, 590, 591; D26/28, 31, 34, 36; 224/527,
224/522, 524

See application file for complete search history.

(56) **References Cited**

U.S. PATENT DOCUMENTS

D401,195 S	*	11/1998	Chimenti	D12/162
5,988,667 A	*	11/1999	Young	280/506
6,105,989 A	*	8/2000	Linger	280/506
6,142,502 A	*	11/2000	Breslin	280/506

* cited by examiner

Primary Examiner—Louis S Zarfaz
Assistant Examiner—Michael A Pratt
(74) *Attorney, Agent, or Firm*—Joe D. Calhoun

(57) **CLAIM**

The ornamental design for a bumper hitch wobble reduction device, as shown and described.

DESCRIPTION

FIG. 1 depicts a perspective view of one embodiment of the invention.

FIG. 2 depicts a top plan view of the invention of FIG. 1

FIG. 3 depicts a bottom plan view of the invention of FIG. 1.

FIG. 4 depicts a front elevation view of the invention of FIG. 1.

FIG. 5 depicts a rear elevation view of the invention of FIG. 1

FIG. 6 depicts a left side elevation plan view of the invention of FIG. 1; and,

FIG. 7 depicts a right side elevation plan view of the invention of FIG. 1.

1 Claim, 3 Drawing Sheets

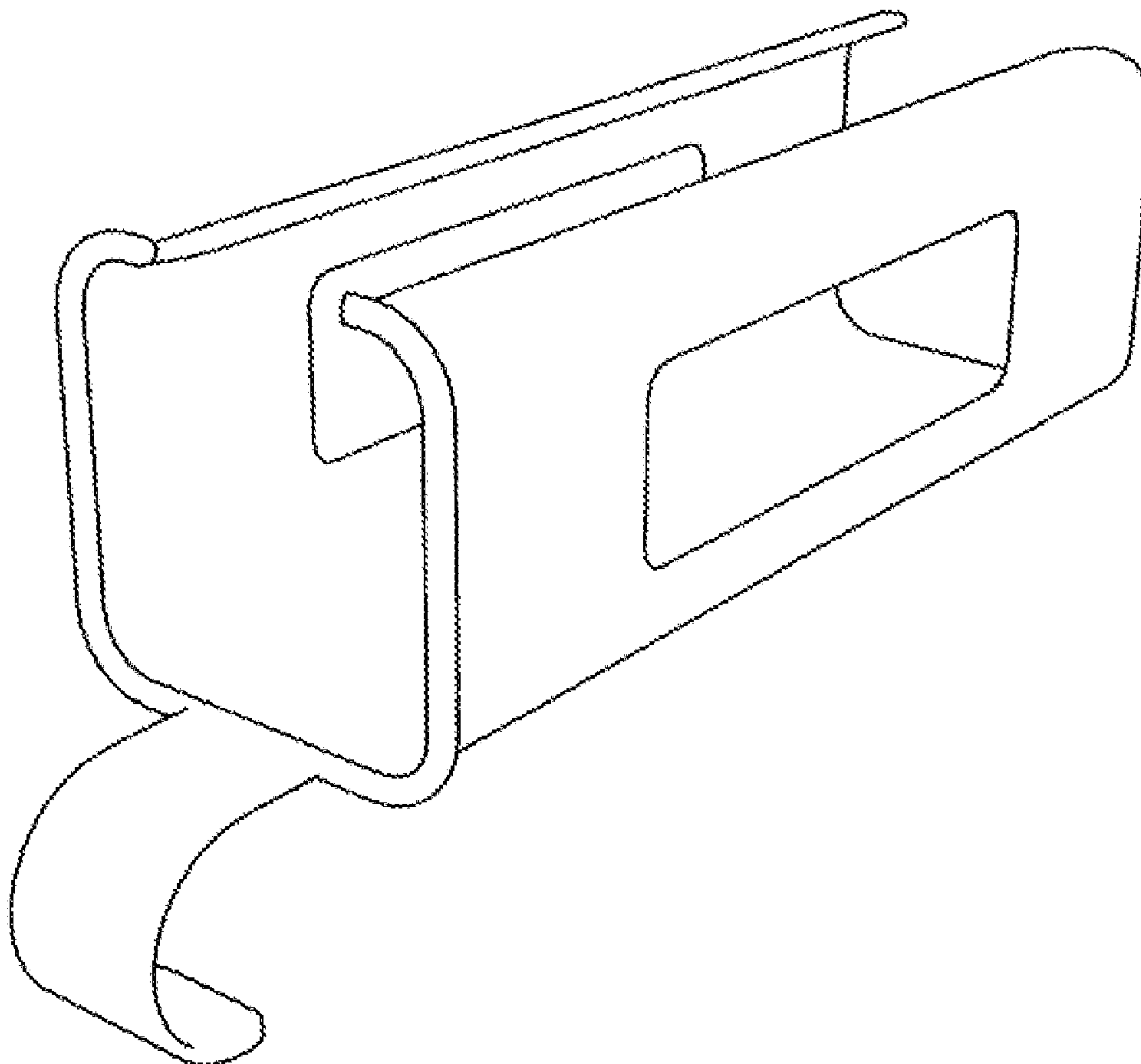

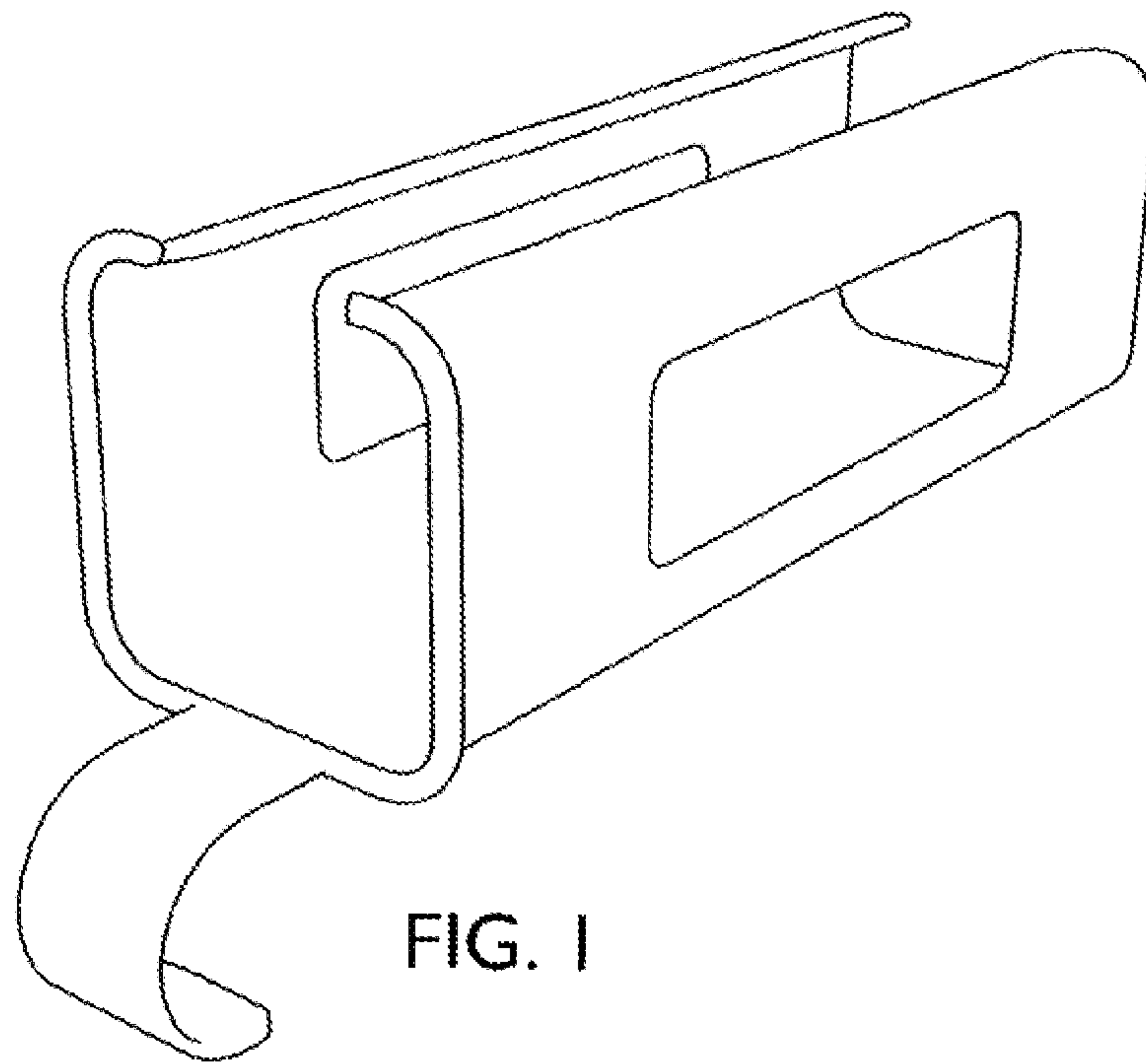

FIG. 1

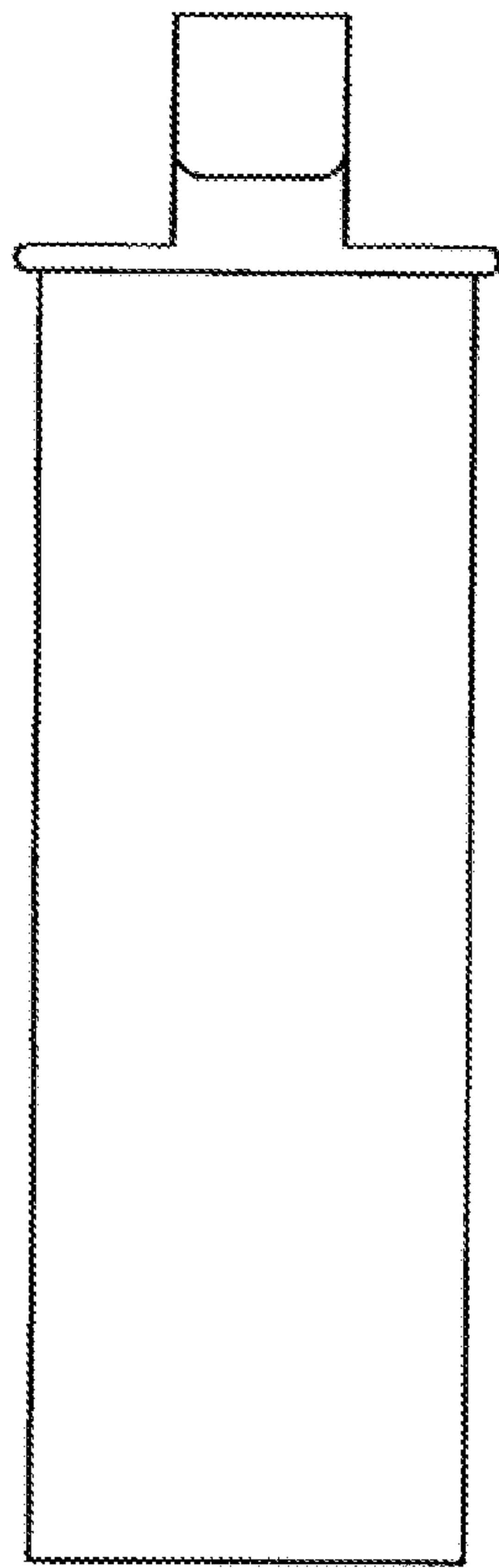

FIG. 3

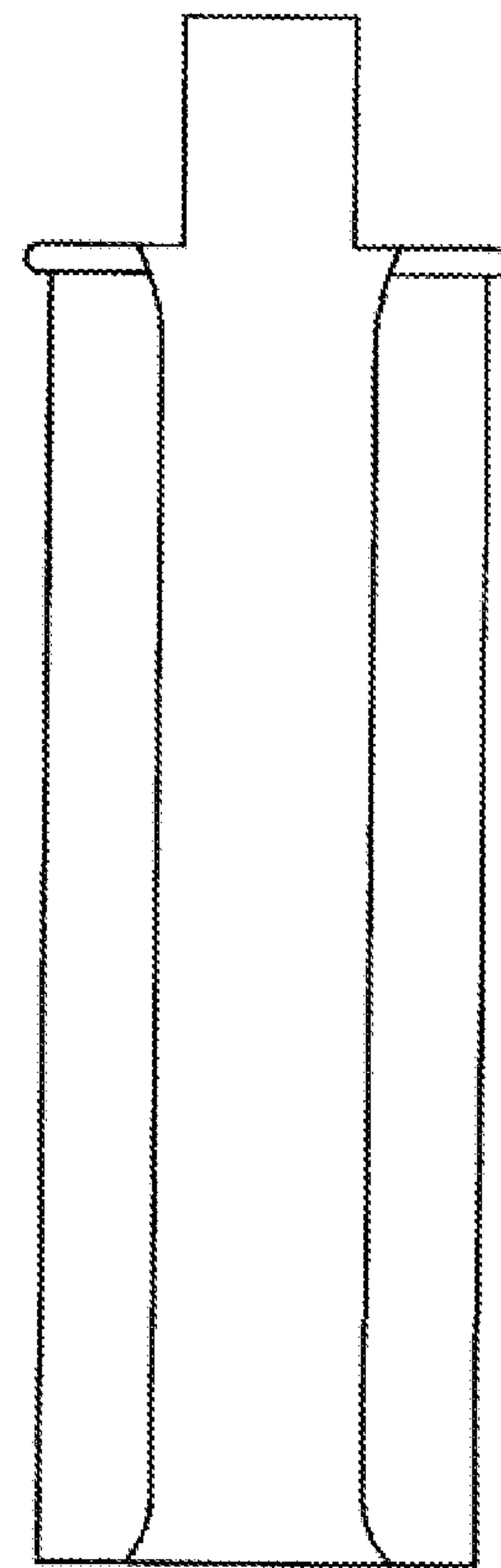

FIG. 2

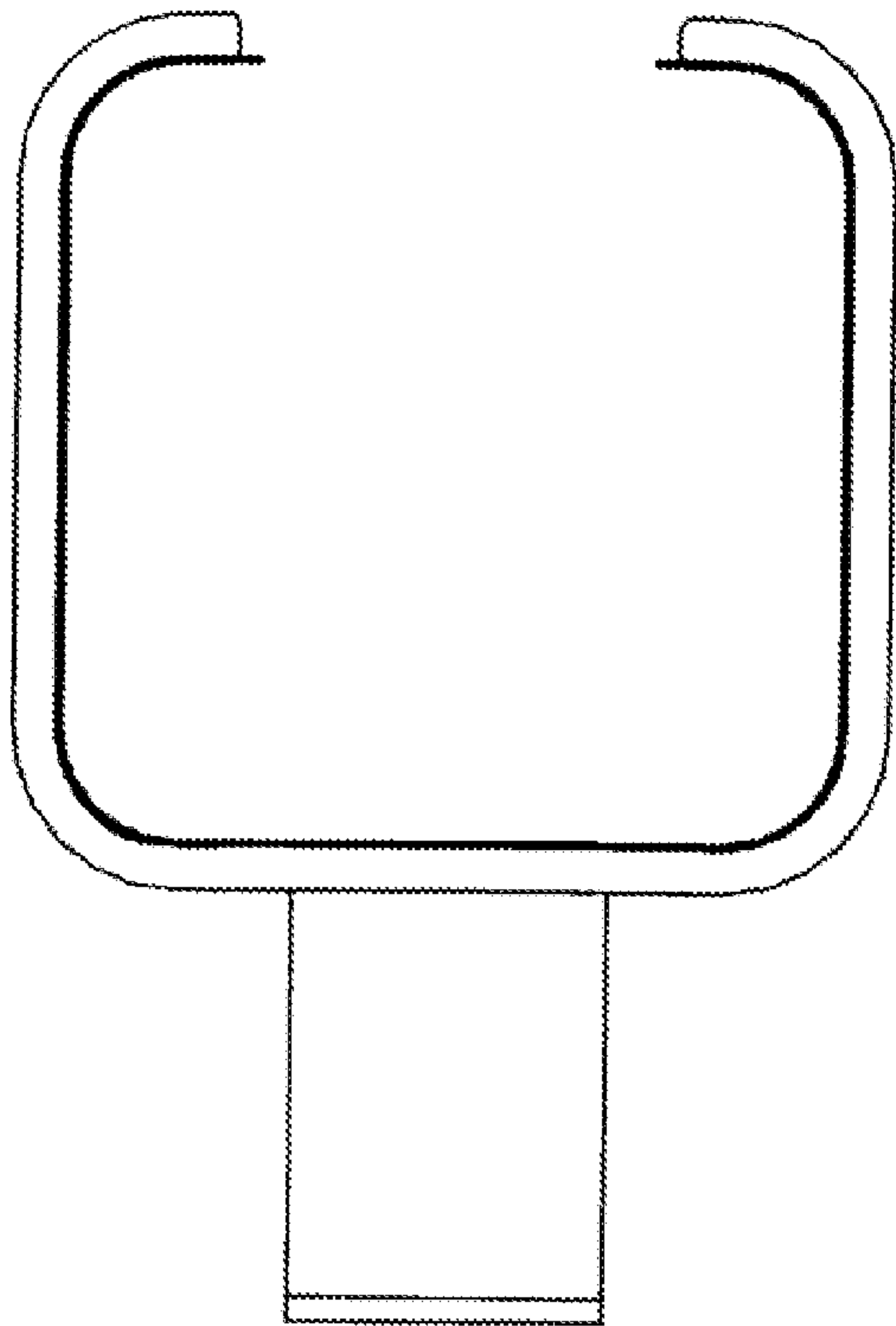

FIG. 4

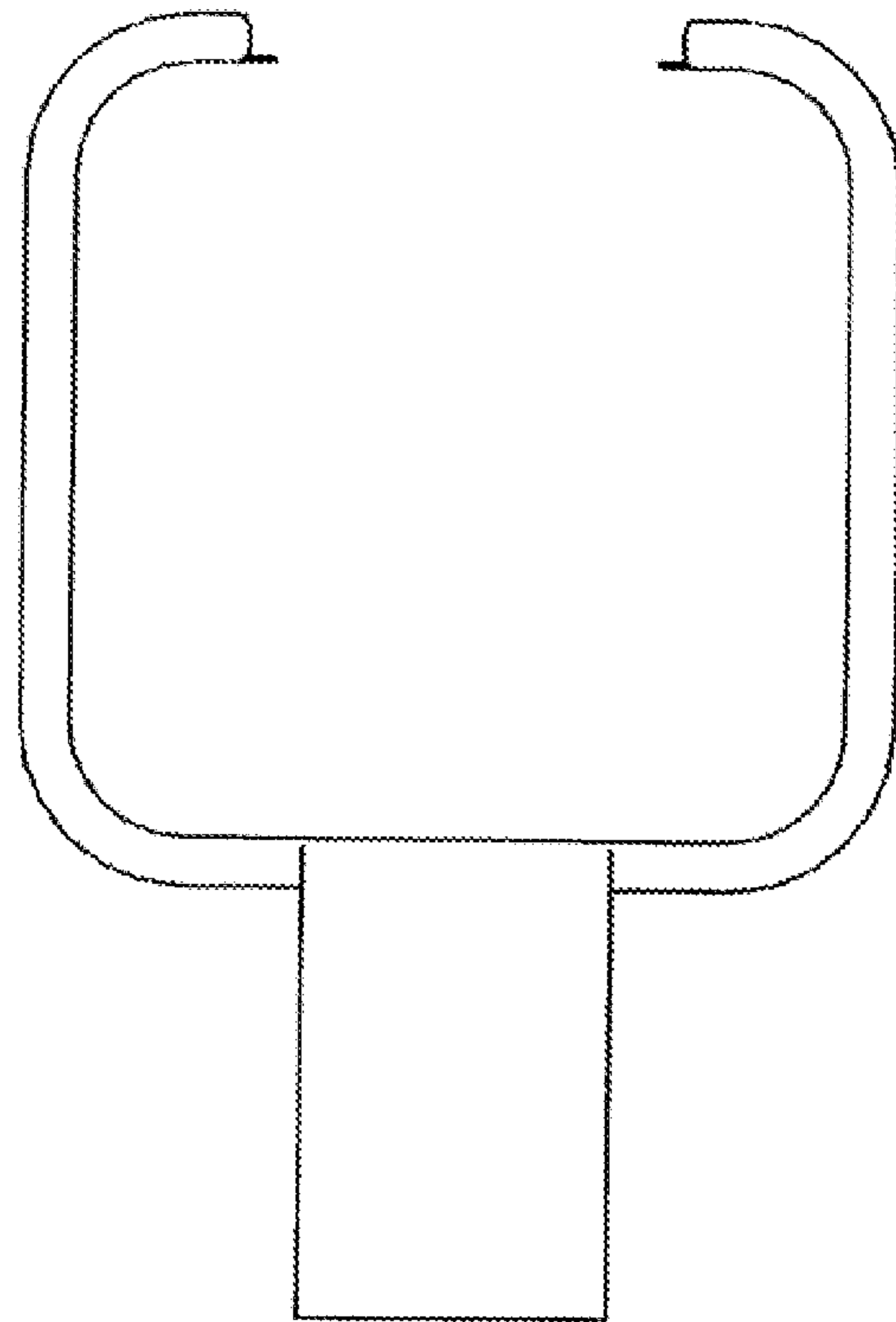

FIG. 5

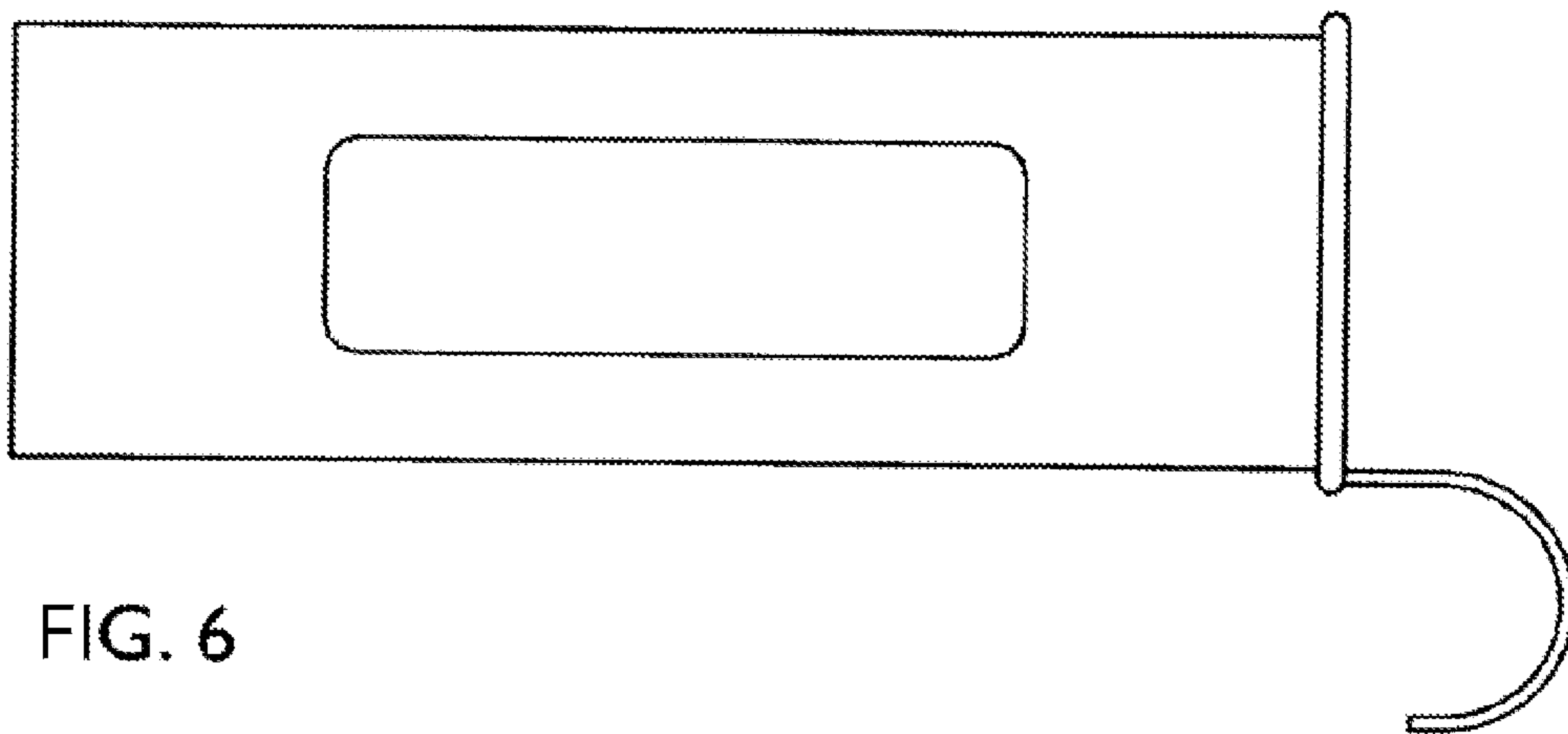

FIG. 6

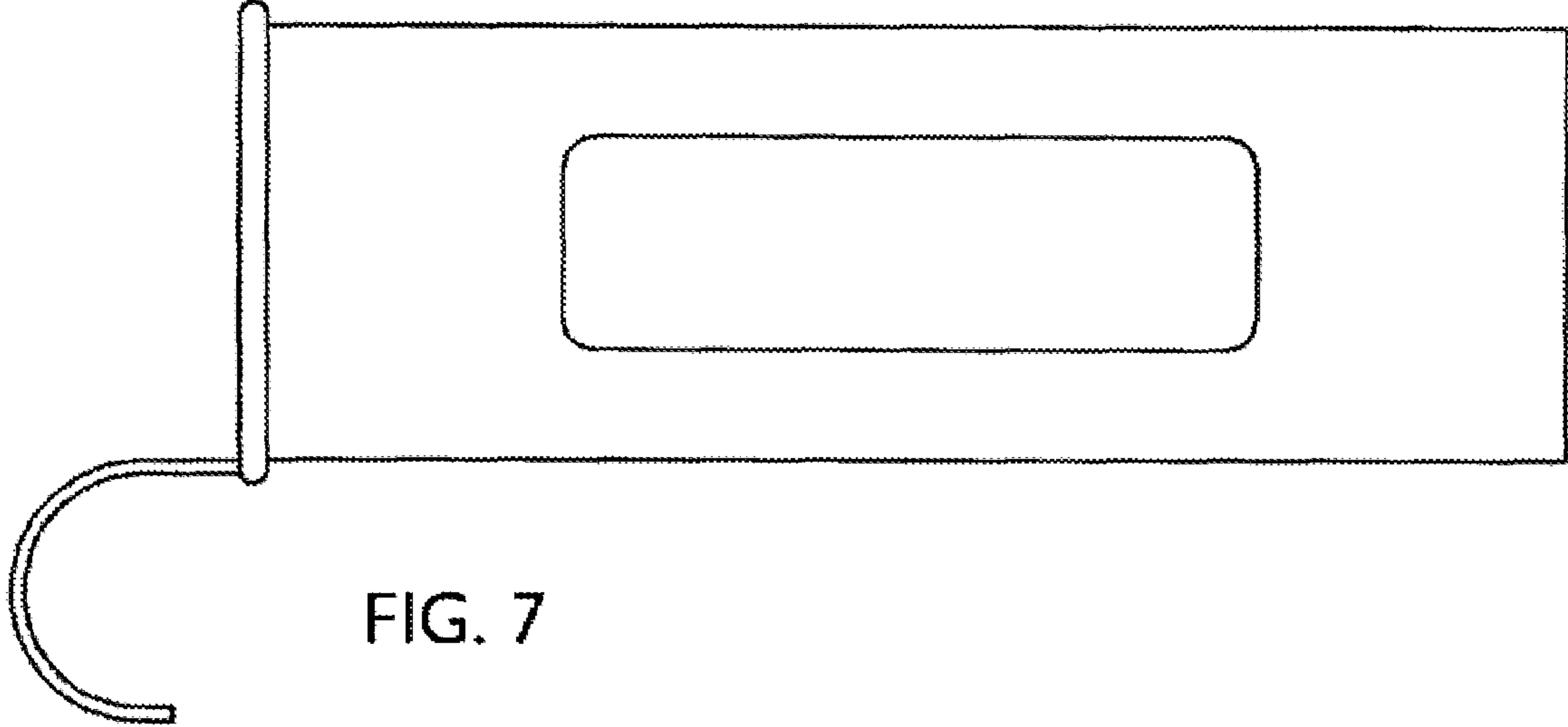

FIG. 7