



US00D576053S

(12) **United States Design Patent**  
**Lulic**

(10) **Patent No.:** **US D576,053 S**  
(45) **Date of Patent:** **\*\* Sep. 2, 2008**

(54) **CLOCK**

(75) Inventor: **Damienne Lulic**, Paris (FR)

(73) Assignee: **Cartier Creation Studio, SA**, Geneva (CH)

(\*\*) Term: **14 Years**

(21) Appl. No.: **29/292,371**

(22) Filed: **Oct. 10, 2007**

(30) **Foreign Application Priority Data**

Apr. 13, 2007 (EM) ..... 000706502

(51) **LOC (8) Cl.** ..... **10-01**

(52) **U.S. Cl.** ..... **D10/24**

(58) **Field of Classification Search** ..... D10/1,  
D10/2, 15, 21, 24, 25, 26, 27; 368/276, 277,  
368/280, 285, 295, 294, 316, 317  
See application file for complete search history.

(56) **References Cited**

U.S. PATENT DOCUMENTS

D94,561 S \* 2/1935 Patten ..... D10/24  
D96,475 S \* 8/1935 Irelan ..... D10/128  
D124,980 S \* 2/1941 Rainbault ..... D10/24  
D233,027 S \* 10/1974 Friedel ..... D10/25  
D265,980 S \* 8/1982 Kanoui ..... D10/26

D268,990 S \* 5/1983 Henkels ..... D10/25  
D269,414 S \* 6/1983 Sugano ..... D10/18  
D314,152 S \* 1/1991 Mayuzumi ..... D10/24  
D316,045 S \* 4/1991 Odaka ..... D10/25  
D316,046 S \* 4/1991 Kato ..... D10/25  
D319,397 S \* 8/1991 Kato ..... D10/26  
D335,629 S \* 5/1993 Takashima ..... D10/18  
D336,048 S \* 6/1993 Nomura et al. .... D10/25  
D365,281 S \* 12/1995 Ng ..... D10/25  
D366,423 S \* 1/1996 Hiromori ..... D10/2

\* cited by examiner

*Primary Examiner*—Lucy Lieberman

(74) *Attorney, Agent, or Firm*—Kalow & Springut, LLP

(57) **CLAIM**

The ornamental design for a clock, as shown and described.

**DESCRIPTION**

FIG. 1 is a perspective view of the clock.

FIG. 2 is a front view of the clock.

FIG. 3 is a rear view of the clock.

FIG. 4 is a left side view of the clock.

FIG. 5 is a right side view of the clock.

FIG. 6 is a top view of the clock; and,

FIG. 7 is a bottom view of the clock.

**1 Claim, 1 Drawing Sheet**

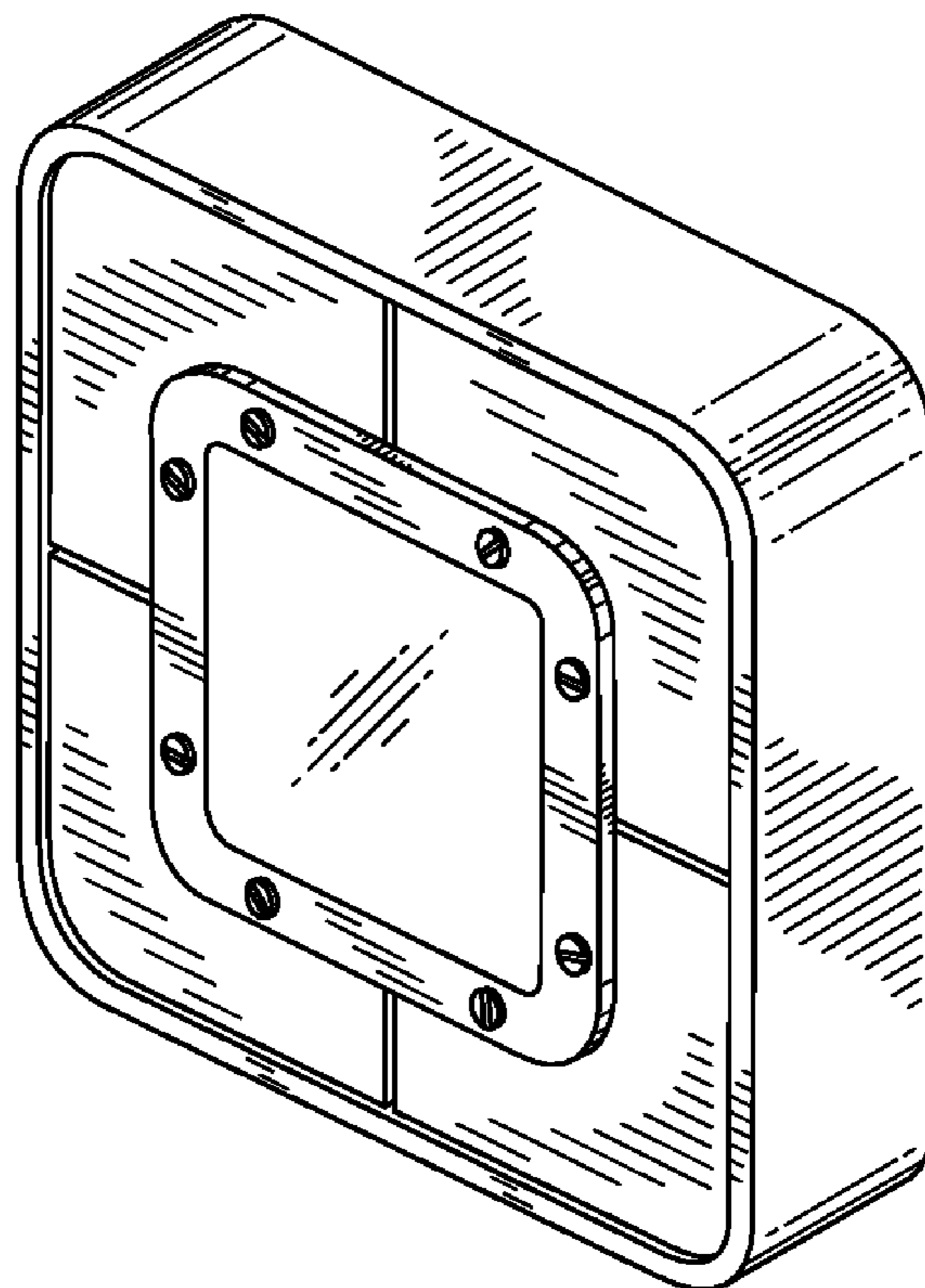

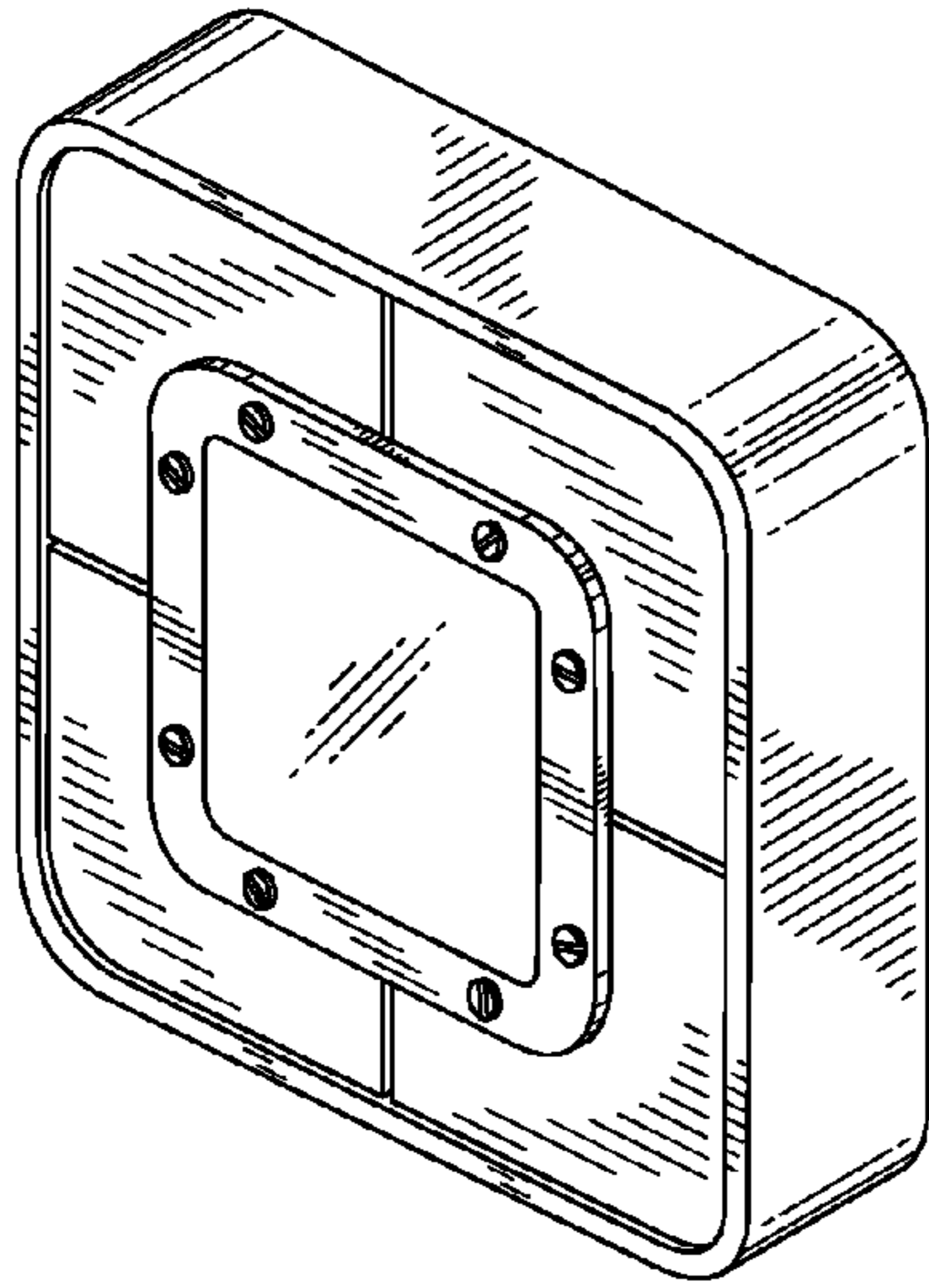

FIG. 1

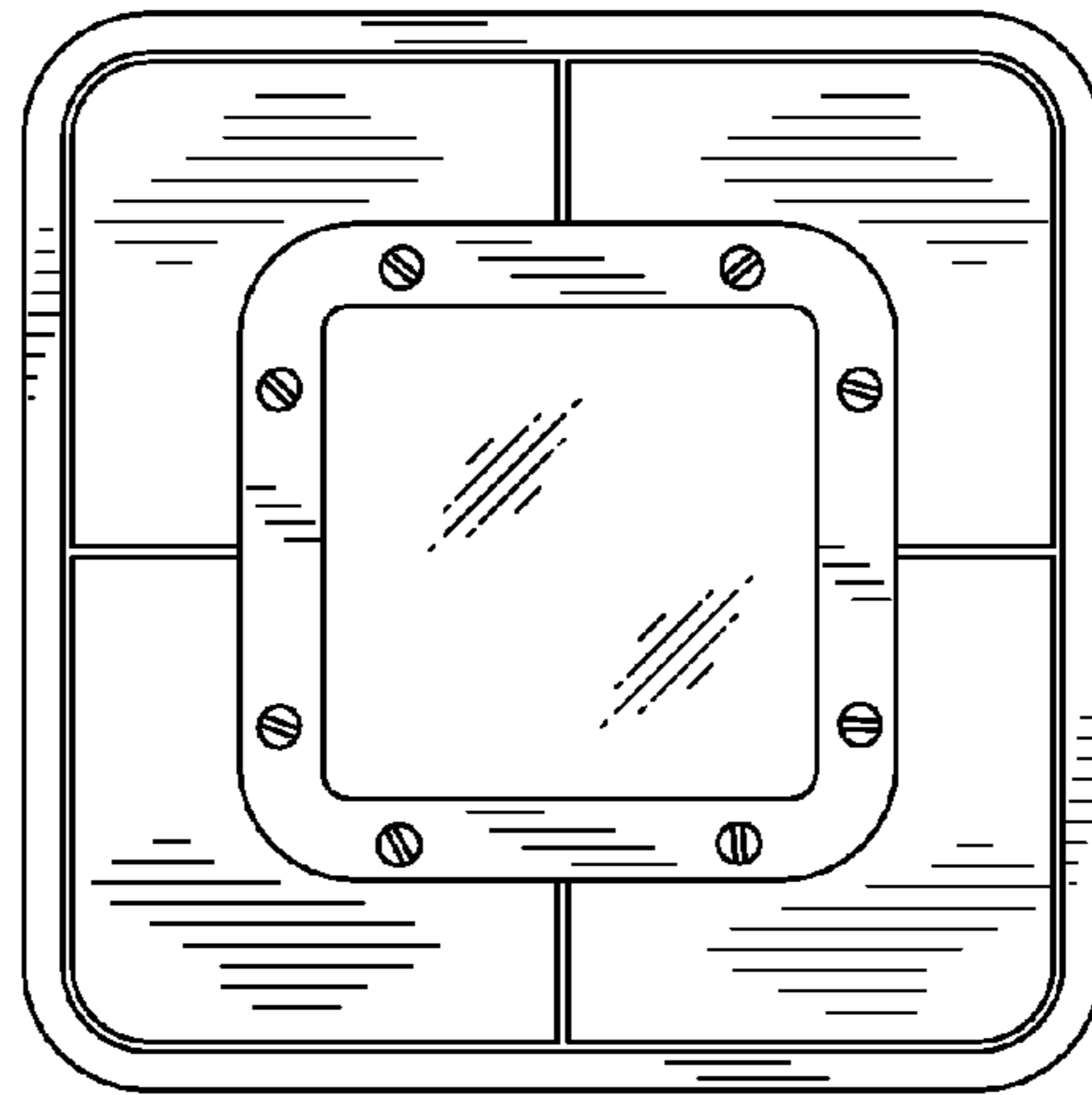

FIG. 2



FIG. 3

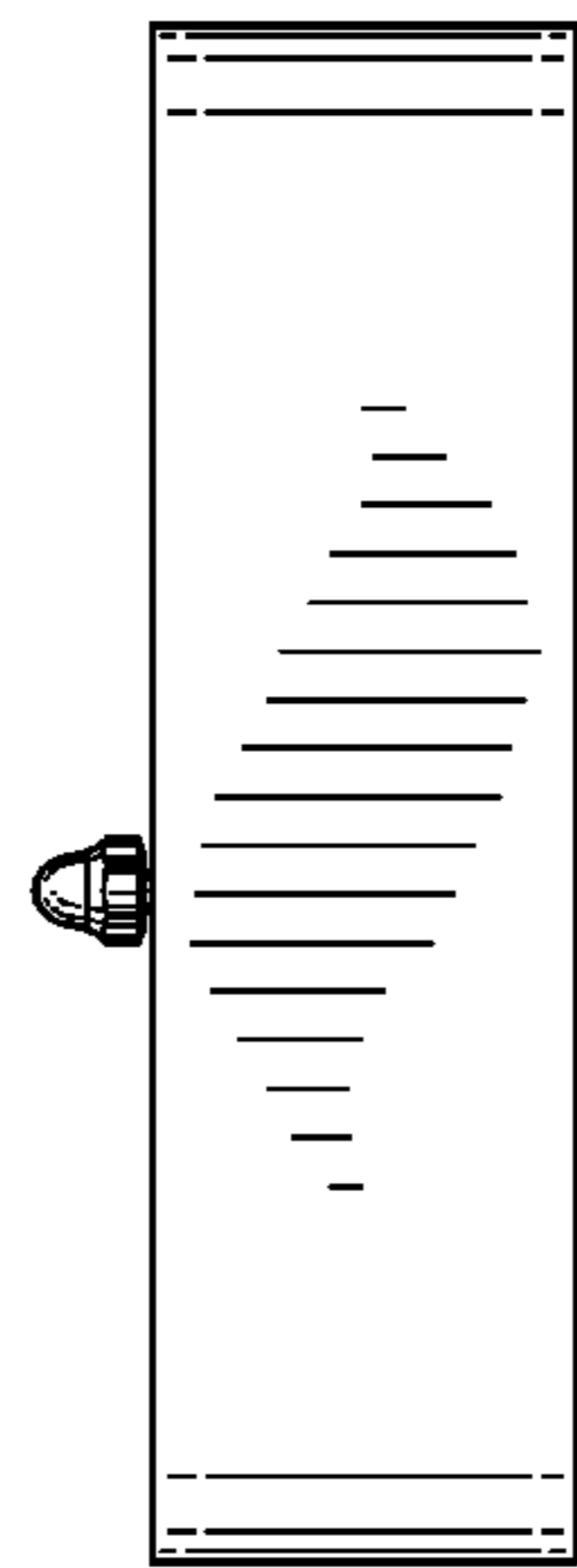

FIG. 4

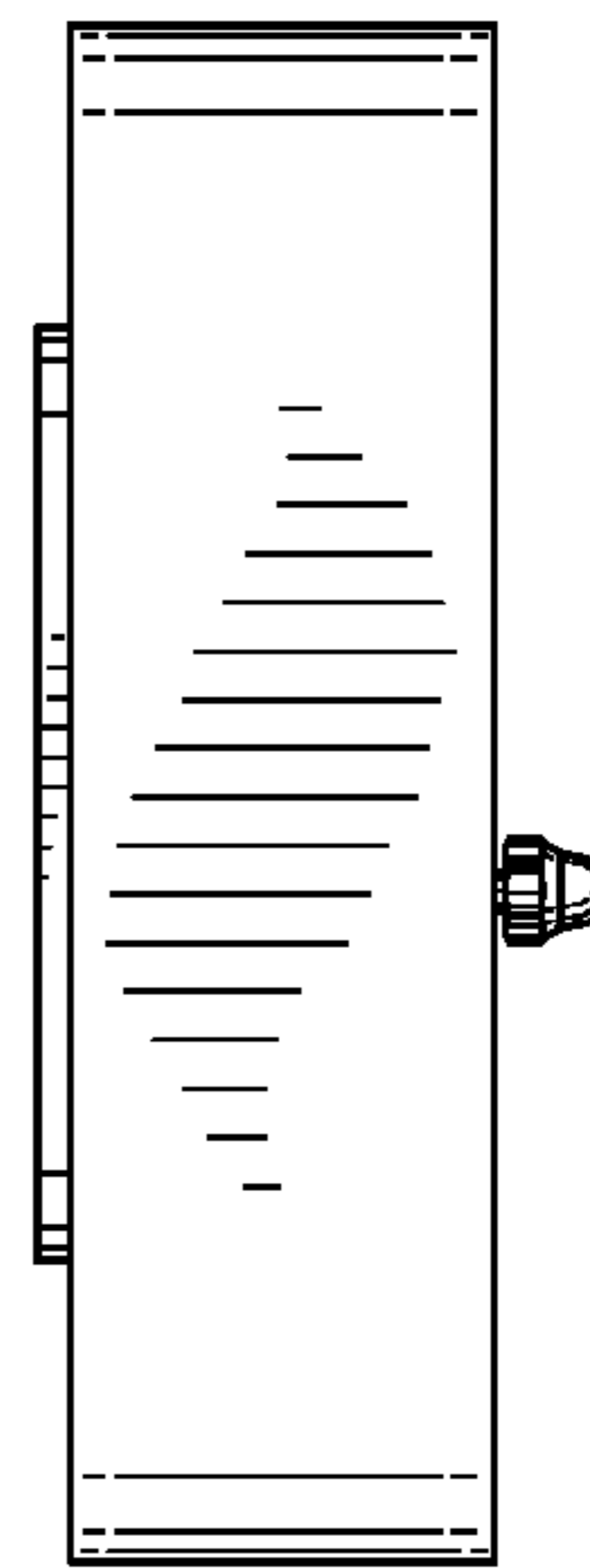

FIG. 5

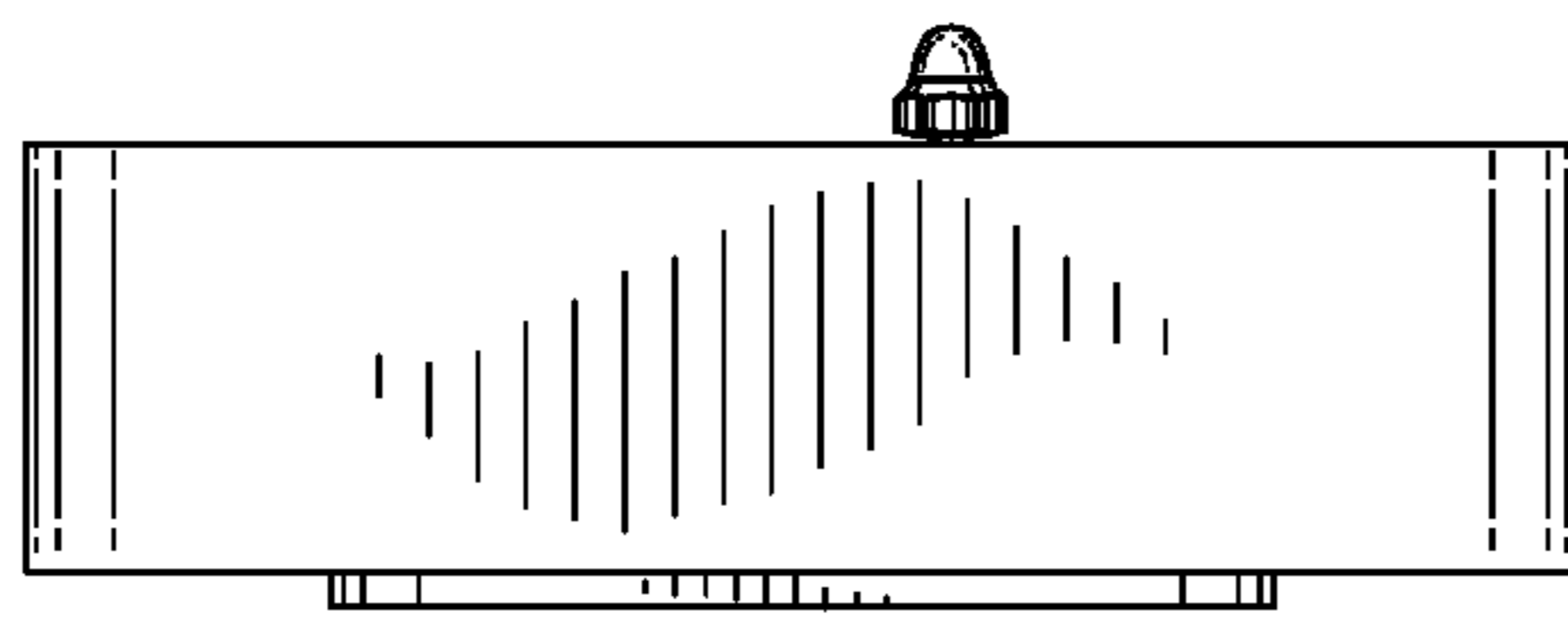

FIG. 6

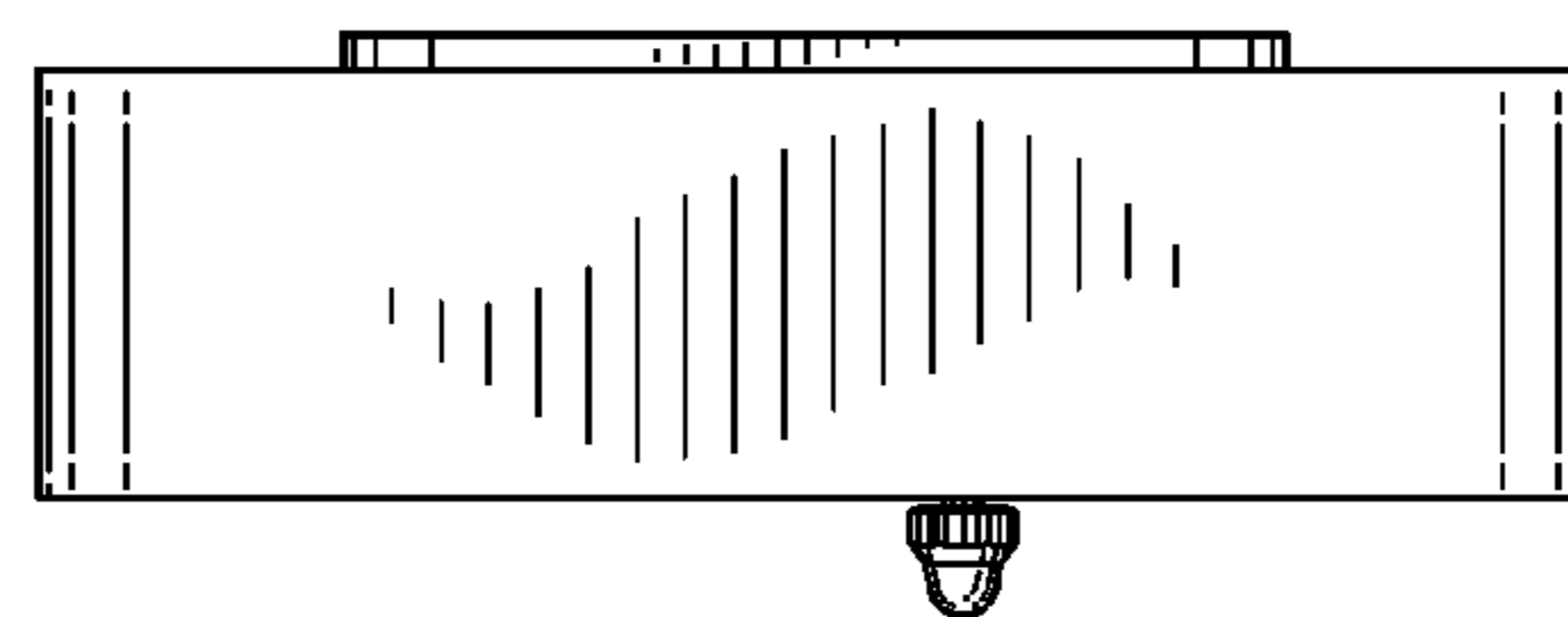

FIG. 7