



US00D575746S

(12) **United States Design Patent**
Bold

(10) **Patent No.:** **US D575,746 S**

(45) **Date of Patent:** **** Aug. 26, 2008**

(54) **BLADE FUSE AND FUSE ELEMENT THEREFORE**

FOREIGN PATENT DOCUMENTS

CH 656979 7/1986

(75) Inventor: **Gary M. Bold**, Palatine, IL (US)

(73) Assignee: **Littelfuse, Inc.**, Des Plaines, IL (US)

(**) Term: **14 Years**

(Continued)

(21) Appl. No.: **29/302,292**

OTHER PUBLICATIONS

(22) Filed: **Jan. 14, 2008**

International Search Report for International Patent Application No. PCT/US05/07484.

(51) **LOC (8) Cl.** **13-03**

Primary Examiner—Daniel D Bui

(52) **U.S. Cl.** **D13/161**

Assistant Examiner—Thomas J Johannes

(58) **Field of Classification Search** D13/158–184;
439/687; 337/163, 198, 206, 230, 264, 265
See application file for complete search history.

(74) *Attorney, Agent, or Firm*—Bell, Boyd & Lloyd LLP

(57) **CLAIM**

(56) **References Cited**

The ornamental design for a blade fuse and fuse element therefore, as shown and described.

U.S. PATENT DOCUMENTS

DESCRIPTION

1,491,905 A	4/1924	Eustice
2,308,435 A	1/1943	Wood
2,863,967 A	12/1958	Swain
3,189,712 A	6/1965	Kozacka
3,261,950 A	7/1966	Kozacka
3,301,978 A	1/1967	Kozacka
3,529,271 A	9/1970	Swain
3,629,036 A	12/1971	Isaacson
3,786,402 A	1/1974	Horecky
3,909,767 A	9/1975	Williamson et al.
3,931,602 A *	1/1976	Plasko 337/163
3,935,553 A	1/1976	Kozacka et al.
3,962,782 A	6/1976	Williamson et al.
4,023,264 A	5/1977	Schmidt, Jr. et al.
4,023,265 A	5/1977	Aryamane
4,040,175 A	8/1977	Williamson et al.
4,056,884 A	11/1977	Williamson et al.
4,059,334 A	11/1977	Bailey
4,067,103 A	1/1978	Ciesmier
4,069,076 A	1/1978	Fickes
4,099,320 A	7/1978	Schmidt, Jr. et al.
4,099,321 A	7/1978	Aryamane
4,099,322 A	7/1978	Tait
4,099,828 A	7/1978	Stegmaier et al.
4,203,200 A	5/1980	Wiebe

FIG. 1 is a perspective view of a blade fuse and fuse element therefore showing my new design;

FIG. 2 is a front view thereof;

FIG. 3 is a side view thereof;

FIG. 4 is a top view thereof;

FIG. 5 is a bottom view thereof; and,

FIG. 6 is another perspective view of a blade fuse and fuse element therefore showing the fuse element in relation to a phantom, claimed, outer casing of the blade fuse for clarity.

The broken line portion of the figure drawings is included to show unclaimed subject matter only and forms no part of the claimed design.

The special dot-dash broken line in FIG. 6 of a phantom, claimed, outer casing of the blade fuse is employed for the sake of clarity in order to show the complete fuse element within.

(Continued)

1 Claim, 3 Drawing Sheets

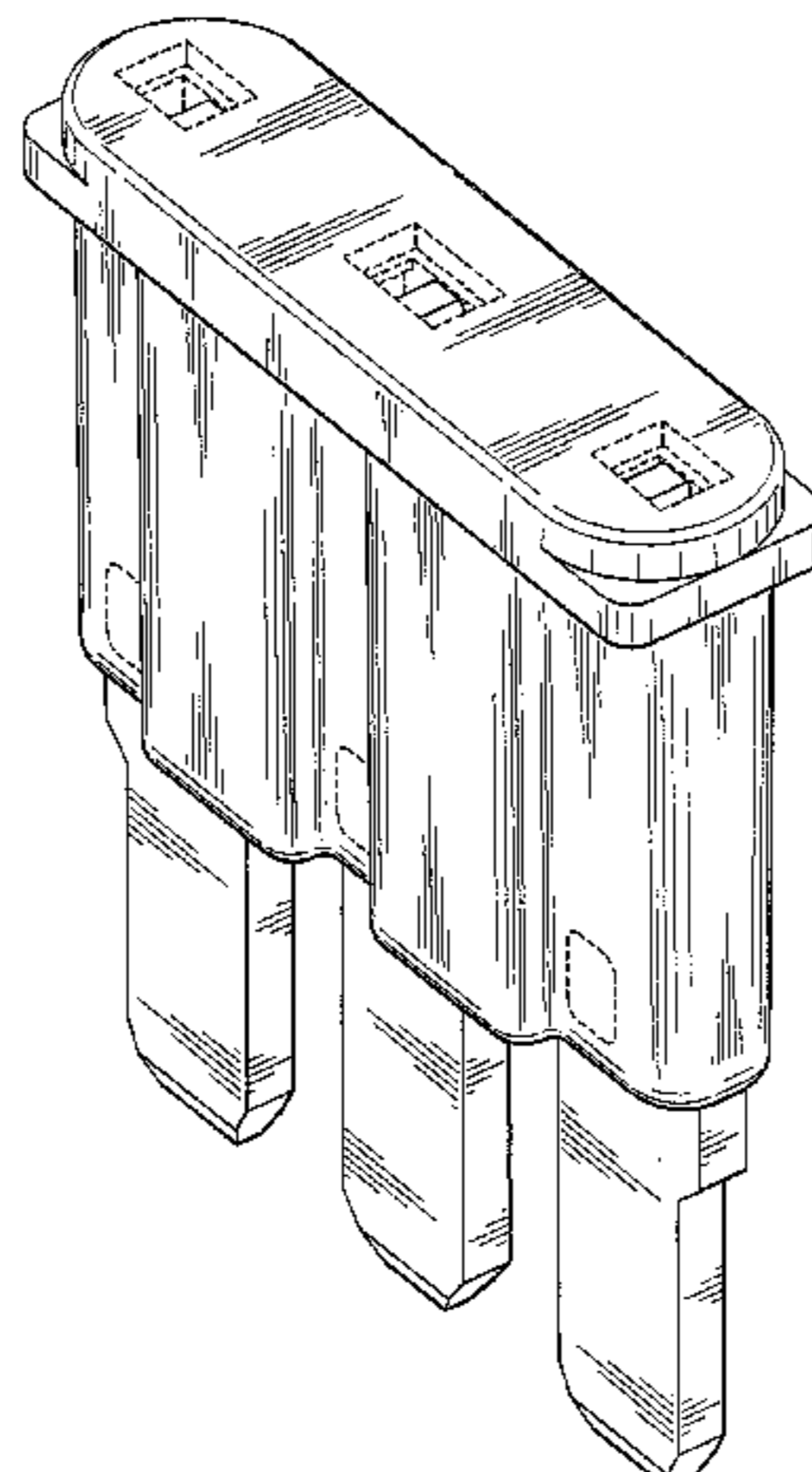

US D575,746 S

U.S. PATENT DOCUMENTS			FOREIGN PATENT DOCUMENTS		
4,221,455 A	9/1980	Cairns et al.	5,552,757 A	9/1996	Blecha et al.
4,221,456 A	9/1980	Cairns et al.	5,581,225 A	12/1996	Oh et al.
4,224,592 A	9/1980	Urani et al.	5,598,138 A	1/1997	Jaronczyk, Jr.
4,245,208 A	1/1981	Belcher	5,601,905 A	2/1997	Watanabe et al.
4,300,281 A	11/1981	Panaro	5,629,664 A	5/1997	Muramatsu et al.
4,343,530 A	8/1982	Leger	5,662,496 A	9/1997	Kanamori
4,344,058 A	8/1982	Knapp, Jr. et al.	5,668,251 A	9/1997	Malik et al.
4,349,804 A *	9/1982	Gaia 337/198	5,668,521 A	9/1997	Oh et al.
4,375,630 A	3/1983	Gaia	5,668,522 A *	9/1997	Kondo et al. 337/198
4,391,485 A	7/1983	Urani	5,726,621 A	3/1998	Whitney et al.
4,414,526 A	11/1983	Panaro	5,736,918 A	4/1998	Douglass
4,417,225 A	11/1983	Müller et al.	5,818,320 A	10/1998	Matsuoka
4,434,548 A	3/1984	Beswick	5,847,635 A	12/1998	Kudo
4,499,447 A	2/1985	Greenberg	5,854,583 A	12/1998	Falchetti
4,500,162 A	2/1985	Keglewitsch et al.	5,898,357 A	4/1999	Endo et al.
4,504,816 A	3/1985	Viola et al.	5,905,426 A	5/1999	Douglass
4,506,004 A	3/1985	Sullivan	5,923,240 A	7/1999	Endo et al.
4,544,907 A	10/1985	Takano	5,929,740 A	7/1999	Oh et al.
4,592,613 A	6/1986	Tong	5,951,328 A	9/1999	Roper, Jr.
4,604,602 A	8/1986	Borzoni	5,963,122 A	10/1999	Endo et al.
4,612,539 A	9/1986	Hosogoe et al.	5,963,123 A	10/1999	Douglass
4,661,793 A *	4/1987	Borzoni 337/260	5,977,859 A	11/1999	Kawamura et al.
4,670,729 A	6/1987	Oh	6,002,322 A	12/1999	Krueger et al.
4,675,990 A	6/1987	Viola et al.	6,011,458 A	1/2000	Endo et al.
4,682,140 A	7/1987	Diaz-Noriega	6,031,446 A	2/2000	Prohaska et al.
4,698,294 A	10/1987	Lau et al.	6,075,689 A	6/2000	Mitchell
4,712,081 A	12/1987	Bosley	6,157,287 A	12/2000	Douglass et al.
4,722,701 A	2/1988	Bradt	6,163,244 A	12/2000	Endo et al.
4,724,606 A	2/1988	Sexton, Jr.	6,168,471 B1	1/2001	Santa Cruz et al.
4,782,317 A	11/1988	Thwaites	6,194,989 B1	2/2001	Douglass
4,827,238 A	5/1989	Kozel	6,222,438 B1	4/2001	Horibe et al.
4,831,353 A	5/1989	Gaia et al.	6,272,000 B1	8/2001	Spaunhorst et al.
4,884,050 A	11/1989	Kozel	6,294,978 B1	9/2001	Endo et al.
4,949,062 A	8/1990	Mollet	6,313,416 B1	11/2001	Abroy et al.
4,949,063 A	8/1990	Levko	D451,889 S	12/2001	Ohashi et al.
4,951,026 A	8/1990	Ehlmann	6,326,878 B1	12/2001	Liang
4,958,426 A	9/1990	Endo et al.	D452,851 S	1/2002	Ohashi et al.
4,972,170 A	11/1990	Ehlmann et al.	D454,842 S	3/2002	Ohashi et al.
4,986,767 A	1/1991	Kozel	6,359,543 B2	3/2002	Endo et al.
4,992,770 A	2/1991	Spalding et al.	6,407,657 B1	6/2002	Oh
4,994,779 A	2/1991	Douglass	6,445,563 B1	9/2002	Endo
4,998,086 A	3/1991	Kourinsky et al.	6,452,474 B1	9/2002	Oh
5,049,095 A	9/1991	Gugelmeyer	6,461,171 B2	10/2002	Kanaoka et al.
D321,683 S	11/1991	Marach	6,529,113 B2	3/2003	Endo et al.
5,075,664 A	12/1991	Spalding et al.	6,531,949 B2	3/2003	Endo et al.
5,077,534 A	12/1991	Douglass	6,542,064 B2	4/2003	Endo et al.
5,085,600 A	2/1992	Damron	6,545,585 B2	4/2003	Endo et al.
5,118,314 A	6/1992	Mangone et al.	6,556,120 B2	4/2003	Endo et al.
5,139,443 A	8/1992	Armando	6,556,121 B2	4/2003	Endo et al.
5,213,945 A	5/1993	Roos et al.	6,616,484 B1	9/2003	Fan Wong
5,227,759 A	7/1993	Hatagishi	6,622,375 B1	9/2003	Endo
5,228,188 A	7/1993	Badihi et al.	6,642,834 B1	11/2003	Oh et al.
5,229,739 A	7/1993	Oh et al.	6,666,722 B2	12/2003	Fukumori et al.
5,235,306 A	8/1993	Kalra et al.	6,666,723 B2	12/2003	Fukumori et al.
5,239,282 A	8/1993	Filomia	6,726,506 B2	4/2004	Fukumori et al.
5,239,291 A	8/1993	Henricks et al.	6,734,780 B2	5/2004	Endo et al.
5,249,985 A	10/1993	Obenauer	6,753,753 B2	6/2004	Endo et al.
5,293,147 A	3/1994	Oh et al.	6,771,477 B2	8/2004	Milanczak
5,296,832 A	3/1994	Perreault et al.	6,848,946 B2	2/2005	Vicenza et al.
5,324,214 A	6/1994	De Castro	D558,150 S *	12/2007	Yang D13/161
5,343,185 A	8/1994	Mosesian et al.	D560,172 S *	1/2008	Ohta et al. D13/161
5,346,411 A	9/1994	Nikkinen	2001/0026209 A1	10/2001	Kond et al.
5,357,234 A	10/1994	Pimpis et al.	2005/0212647 A1 *	9/2005	Goldsberry et al. 337/198
5,373,278 A	12/1994	Saulgeot et al.			
5,405,731 A	4/1995	Chandrasekaran et al.	DE	2500364	7/1975
5,426,411 A	6/1995	Pimpis et al.	DE	3040884	5/1982
5,444,428 A	8/1995	Carr et al.	DE	10358444	7/2005
5,476,395 A	12/1995	Raffles et al.	GB	2090081	6/1982
5,476,396 A	12/1995	De Castro	JP	54-133203	10/1979
5,507,669 A	4/1996	Jannett et al.	JP	56-2560	1/1981
D373,570 S	9/1996	Kudo et al.	JP	56-2561	1/1981

US D575,746 S

Page 3

JP	56-51239	5/1981
JP	56-90354	7/1981
JP	56-92862	7/1981
JP	57-204647	12/1982

JP	58-154549	9/1983
JP	2000-260290	9/2000
JP	2000-260294	9/2000

* cited by examiner

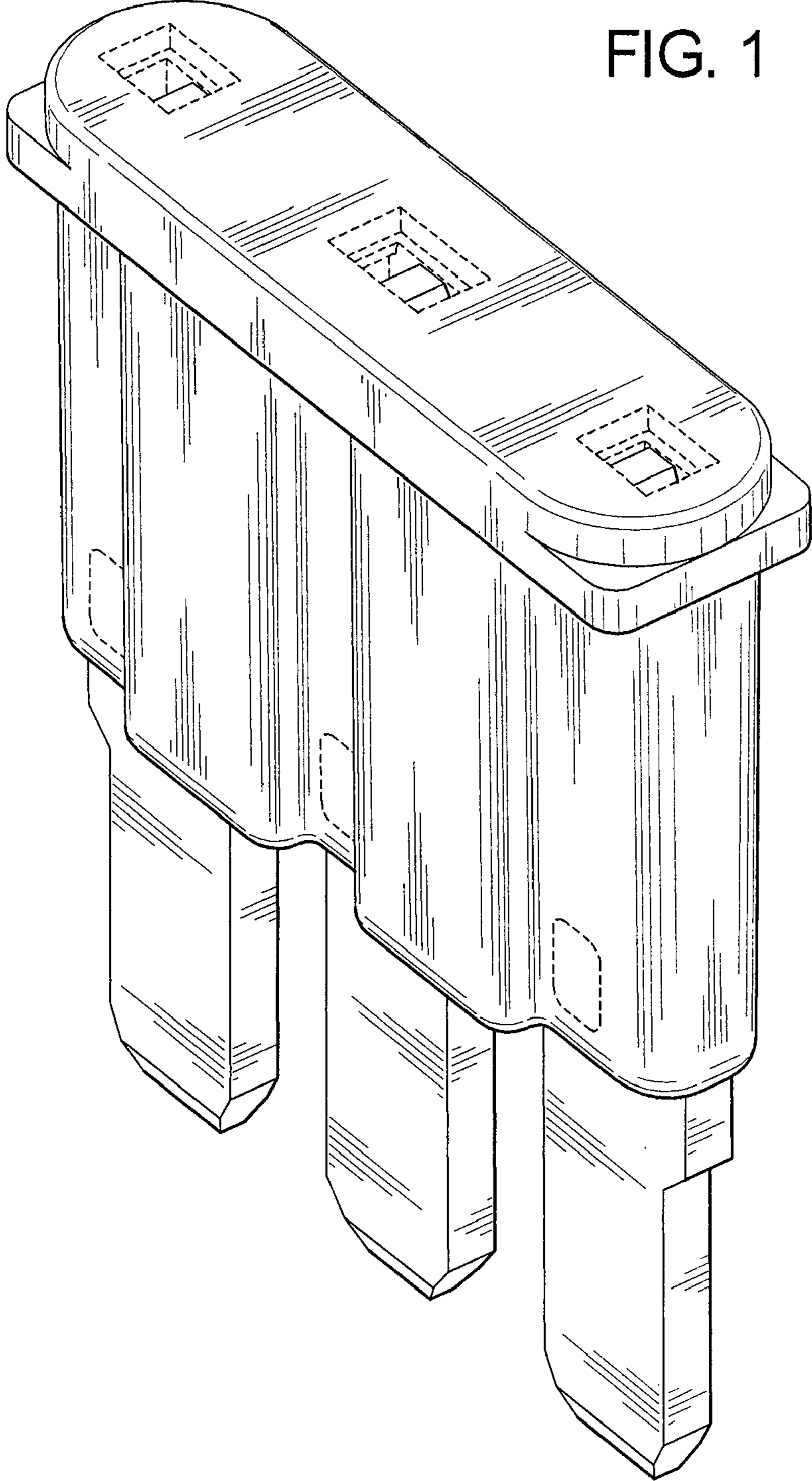

FIG. 1

FIG. 2

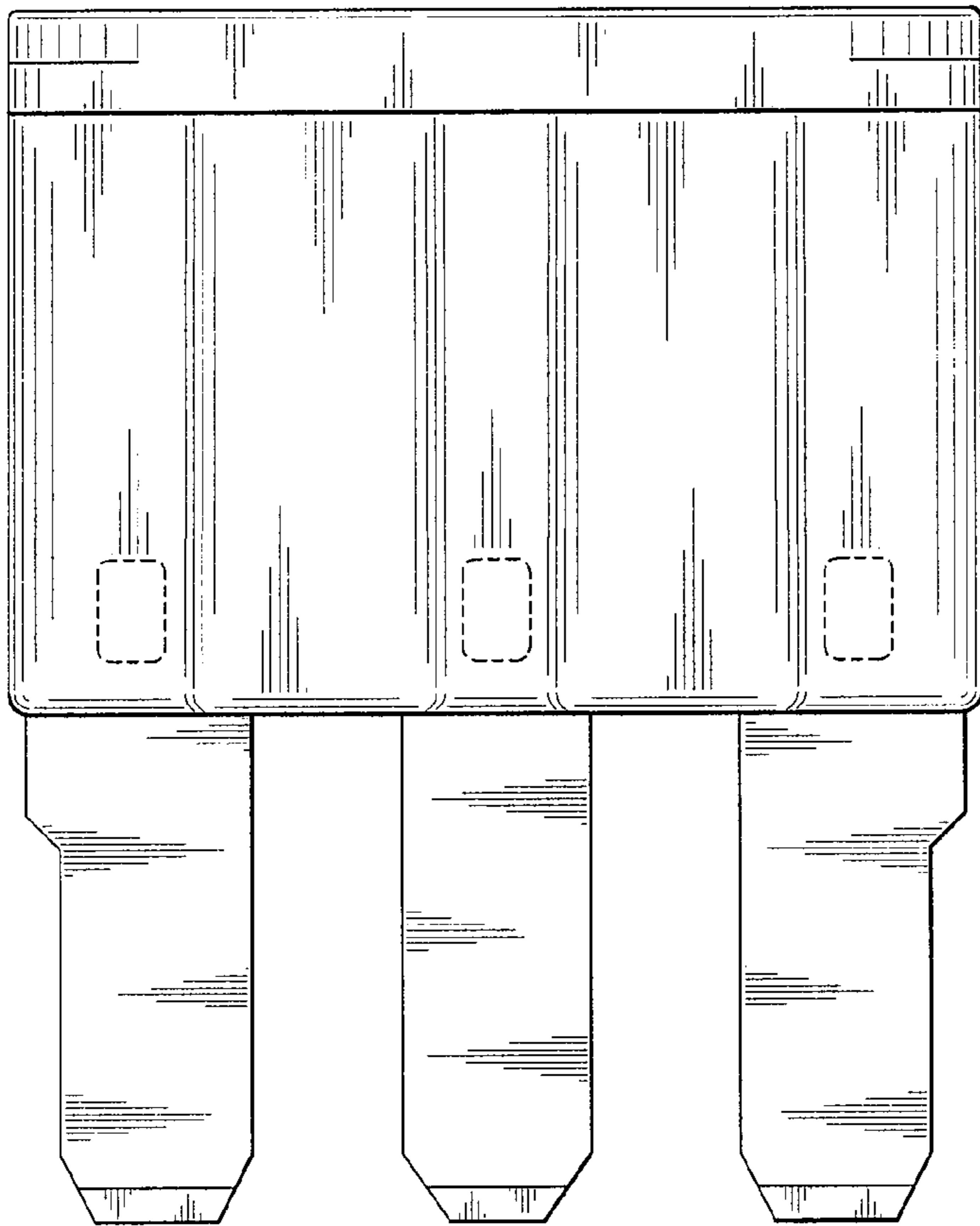

FIG. 3

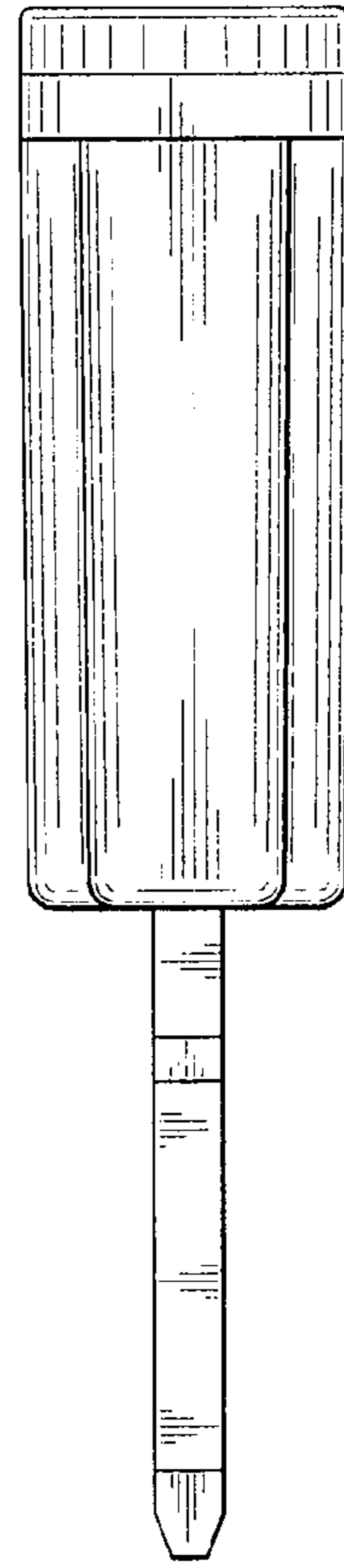

FIG. 4

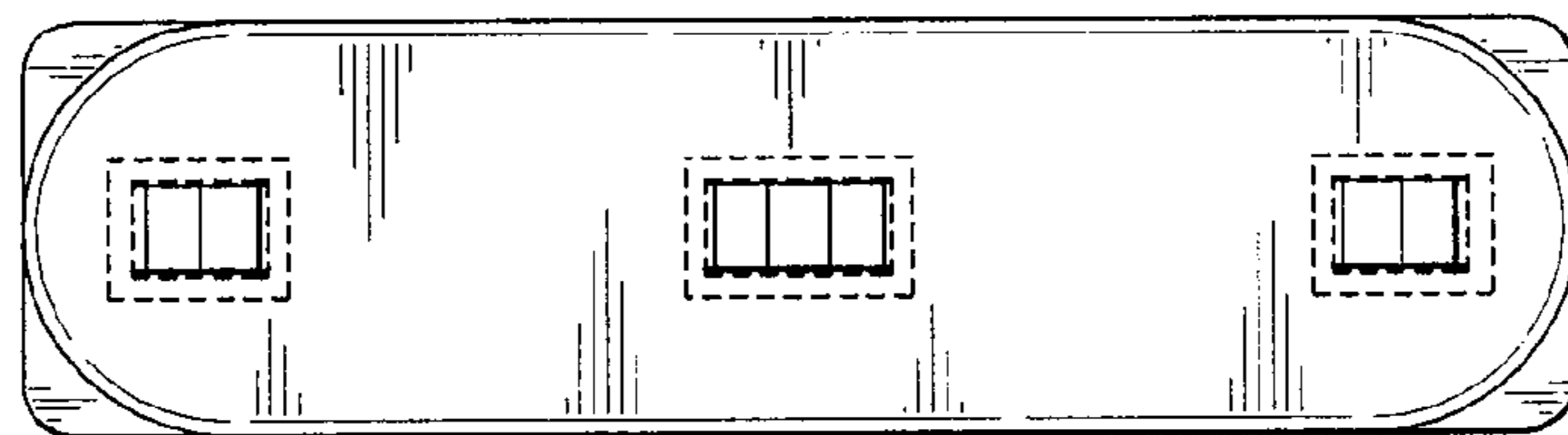

FIG. 5

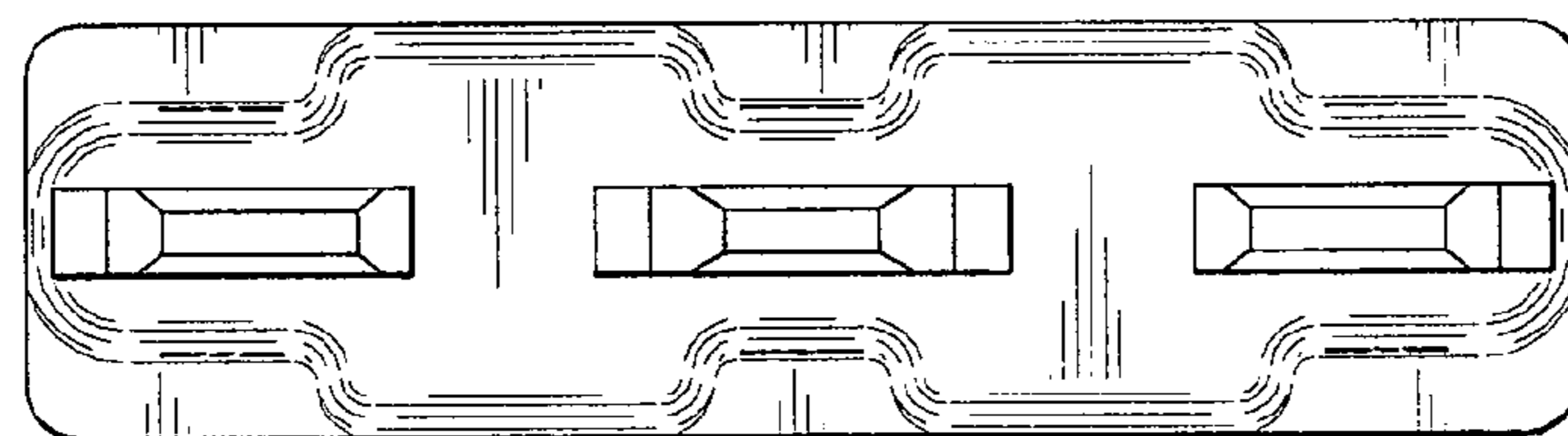

FIG. 6

