



US00D575707S

(12) **United States Design Patent**  
**Futschik et al.**

(10) **Patent No.:** **US D575,707 S**

(45) **Date of Patent:** **\*\* Aug. 26, 2008**

(54) **FOOT FOR A SIDE MIRROR FOR A VEHICLE**

(75) Inventors: **Hans-Dieter Futschik**, Gechingen (DE);  
**Christian Guntrum**, Leonberg (DE);  
**Steffen Koehl**, Stuttgart (DE);  
**Karl-Heinz Naegele**, Bondorf (DE)

(73) Assignee: **Daimler AG**, Stuttgart (DE)

(\*\*) Term: **14 Years**

(21) Appl. No.: **29/290,521**

(22) Filed: **Dec. 12, 2007**

(30) **Foreign Application Priority Data**

Jun. 13, 2007 (EM) ..... 000739131-0003

(51) **LOC (8) Cl.** ..... **12-16**

(52) **U.S. Cl.** ..... **D12/187**

(58) **Field of Classification Search** ..... D12/187-199,  
D12/96; D6/300, 309; 359/838, 841, 843,  
359/844, 868, 871, 872, 877, 604, 881, 514,  
359/866; 248/475.1, 479-483

See application file for complete search history.

(56) **References Cited**

**U.S. PATENT DOCUMENTS**

D249,340 S \* 9/1978 Braid ..... D12/187  
D250,702 S \* 1/1979 VandenBrink et al. .... D12/187  
6,260,977 B1 \* 7/2001 Inagaki ..... 359/872  
D519,428 S \* 4/2006 Ervolina ..... D12/187  
D551,605 S \* 9/2007 Pfeiffer ..... D12/187

\* cited by examiner

*Primary Examiner*—Robert M. Spear

*Assistant Examiner*—Katrina A Kile

(74) *Attorney, Agent, or Firm*—Crowell & Moring LLP

(57) **CLAIM**

The ornamental design for a foot for a side mirror for a vehicle, as shown and described.

**DESCRIPTION**

This application is related to the following co-pending application: Application Ser. No. 29/290,520, entitled “Side Mirror for a Vehicle”.

FIG. 1 is a perspective view of a first embodiment of a foot for a side mirror for a vehicle according to our novel design;

FIG. 2 is a front view thereof;

FIG. 3 is a side view thereof;

FIG. 4 is a rear view thereof;

FIG. 5 is a top view thereof; and

FIG. 6 is a bottom view thereof.

FIG. 7 is a perspective view of a second embodiment of the foot for a side mirror for a vehicle according to our novel design;

FIG. 8 is a front view thereof;

FIG. 9 is a side view thereof;

FIG. 10 is a rear view thereof;

FIG. 11 is a top view thereof; and,

FIG. 12 is a bottom view thereof.

In the drawings, the broken lines depict a portion of a vehicle and form no part of the claimed design.

**1 Claim, 8 Drawing Sheets**

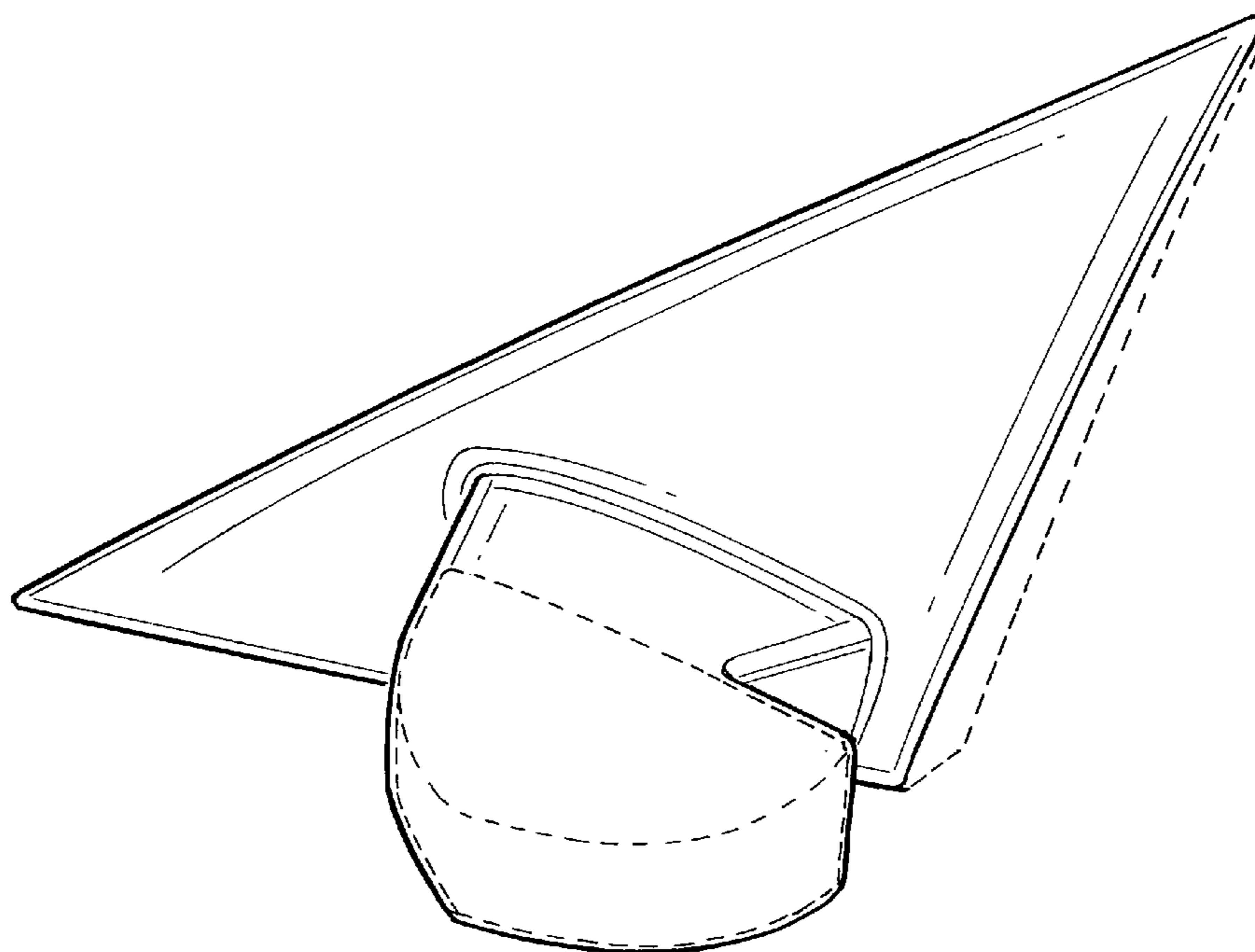

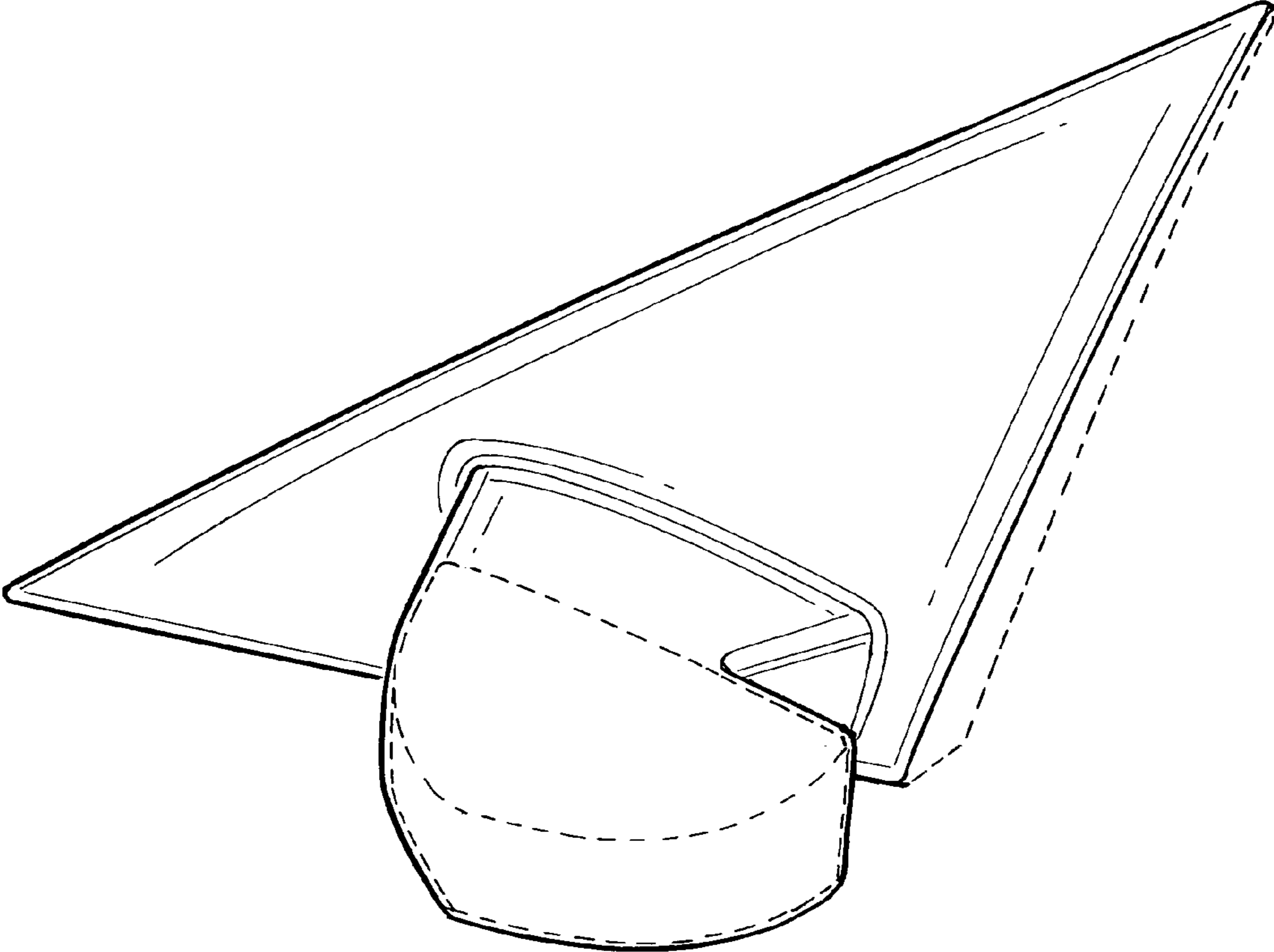

FIG. 1

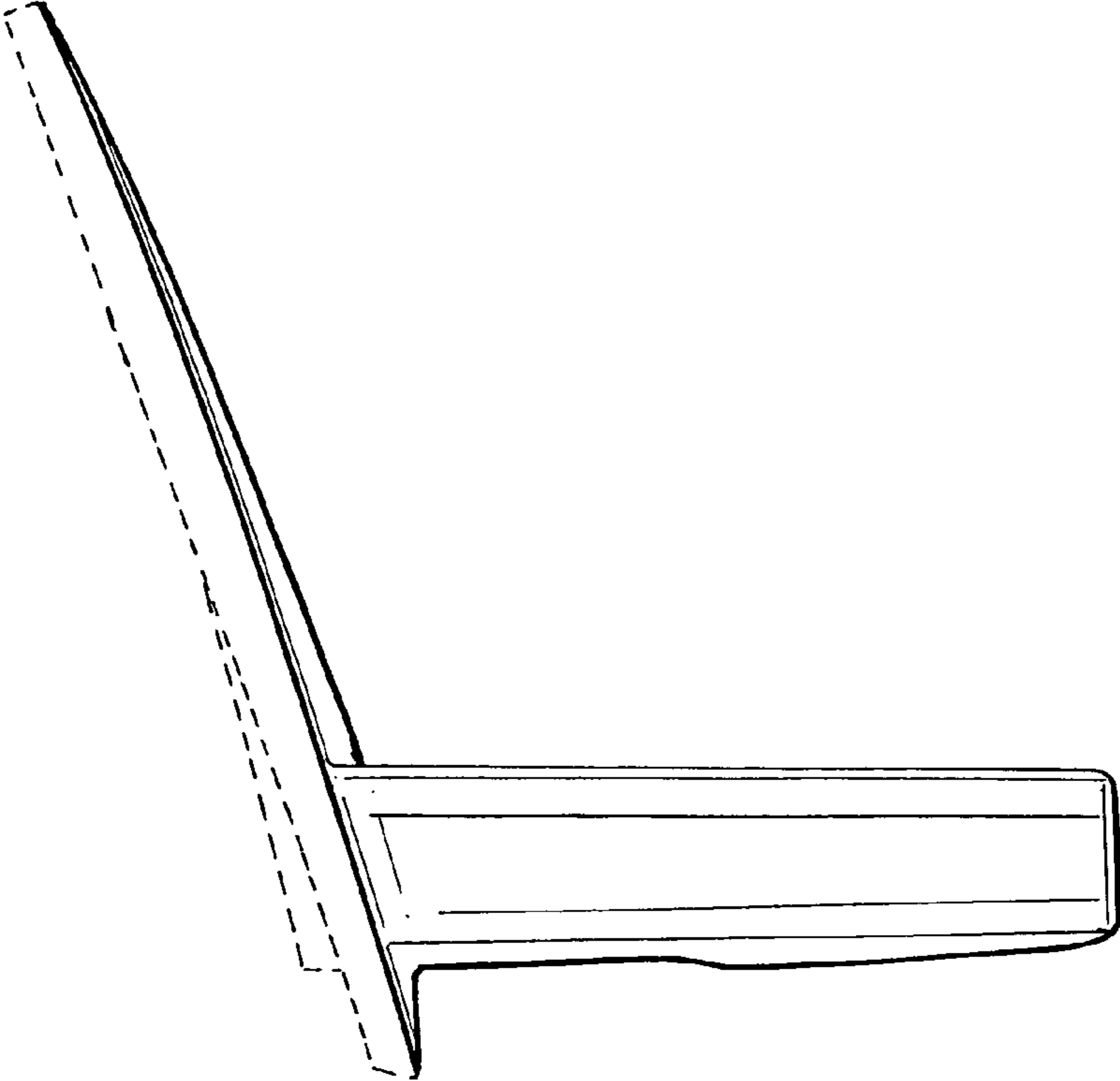

FIG. 2

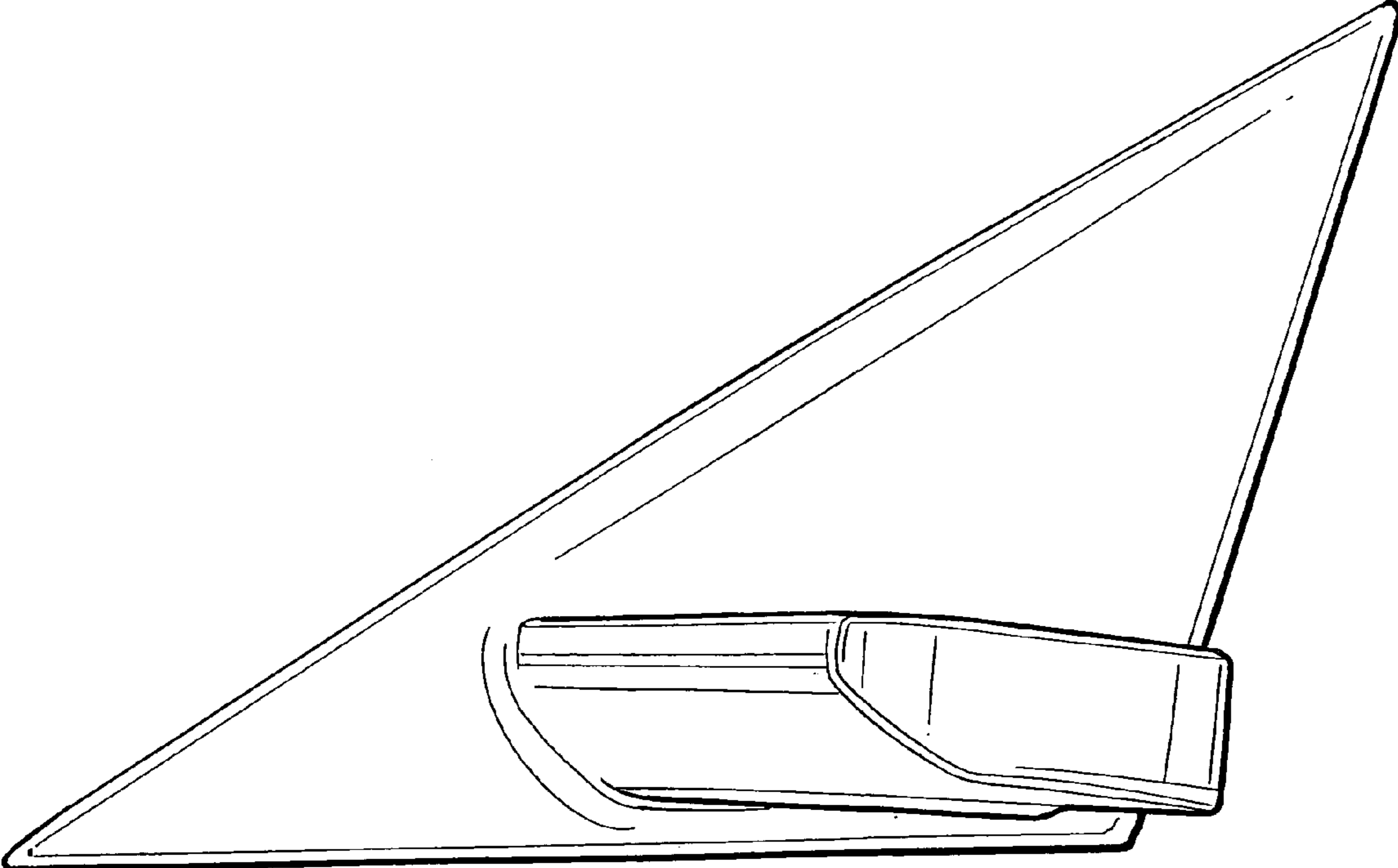

FIG. 3

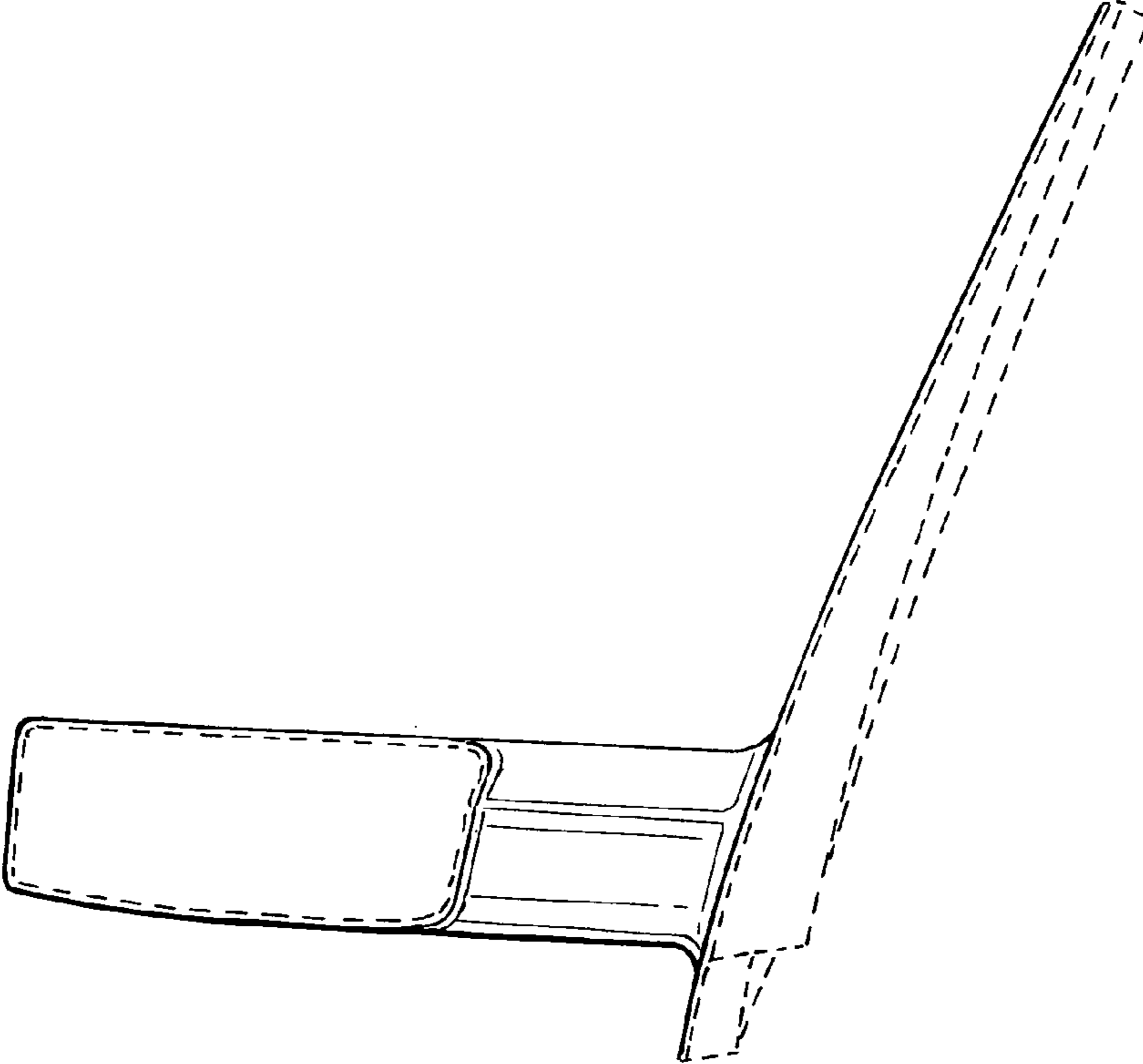

FIG. 4

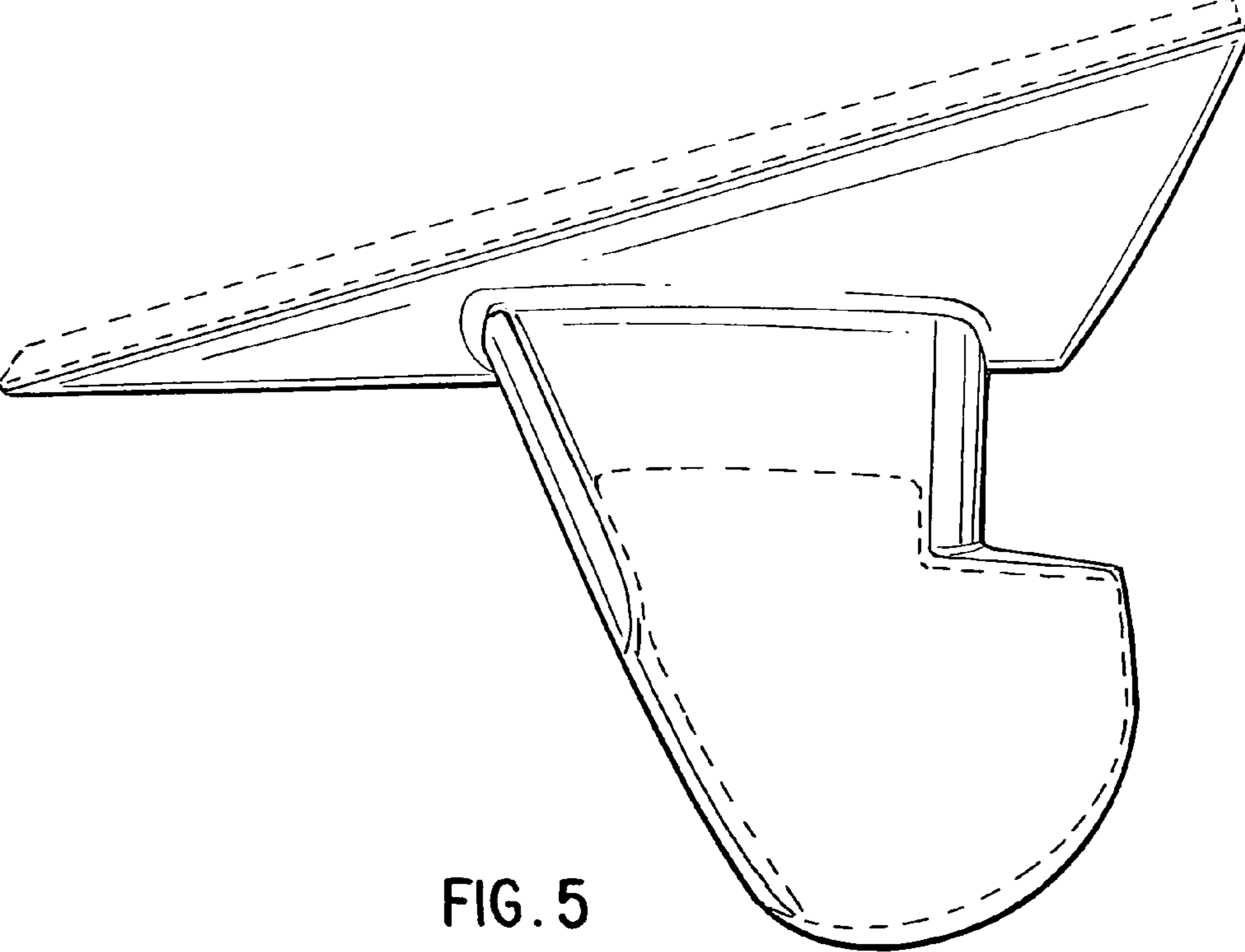

FIG. 5

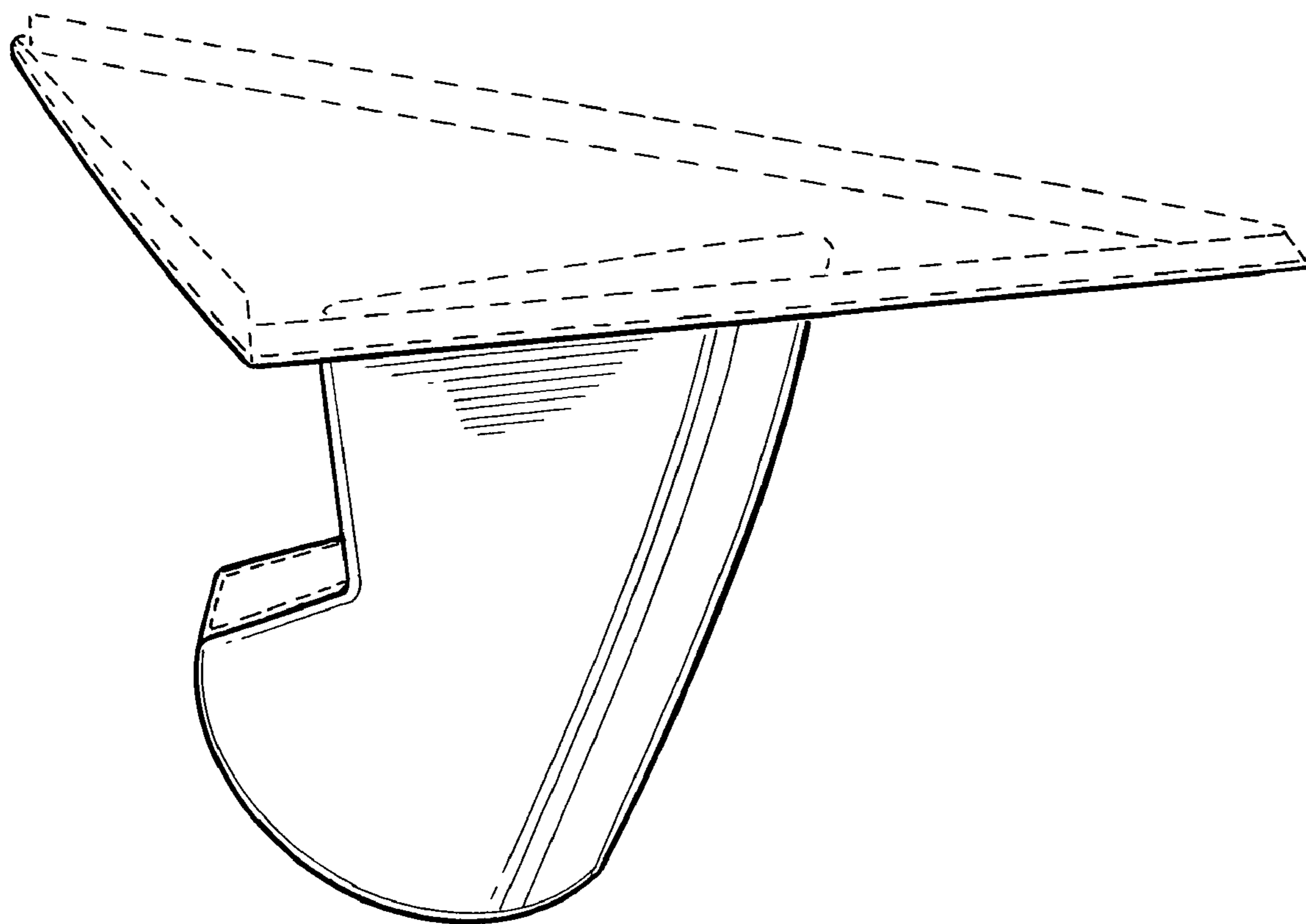

FIG. 6

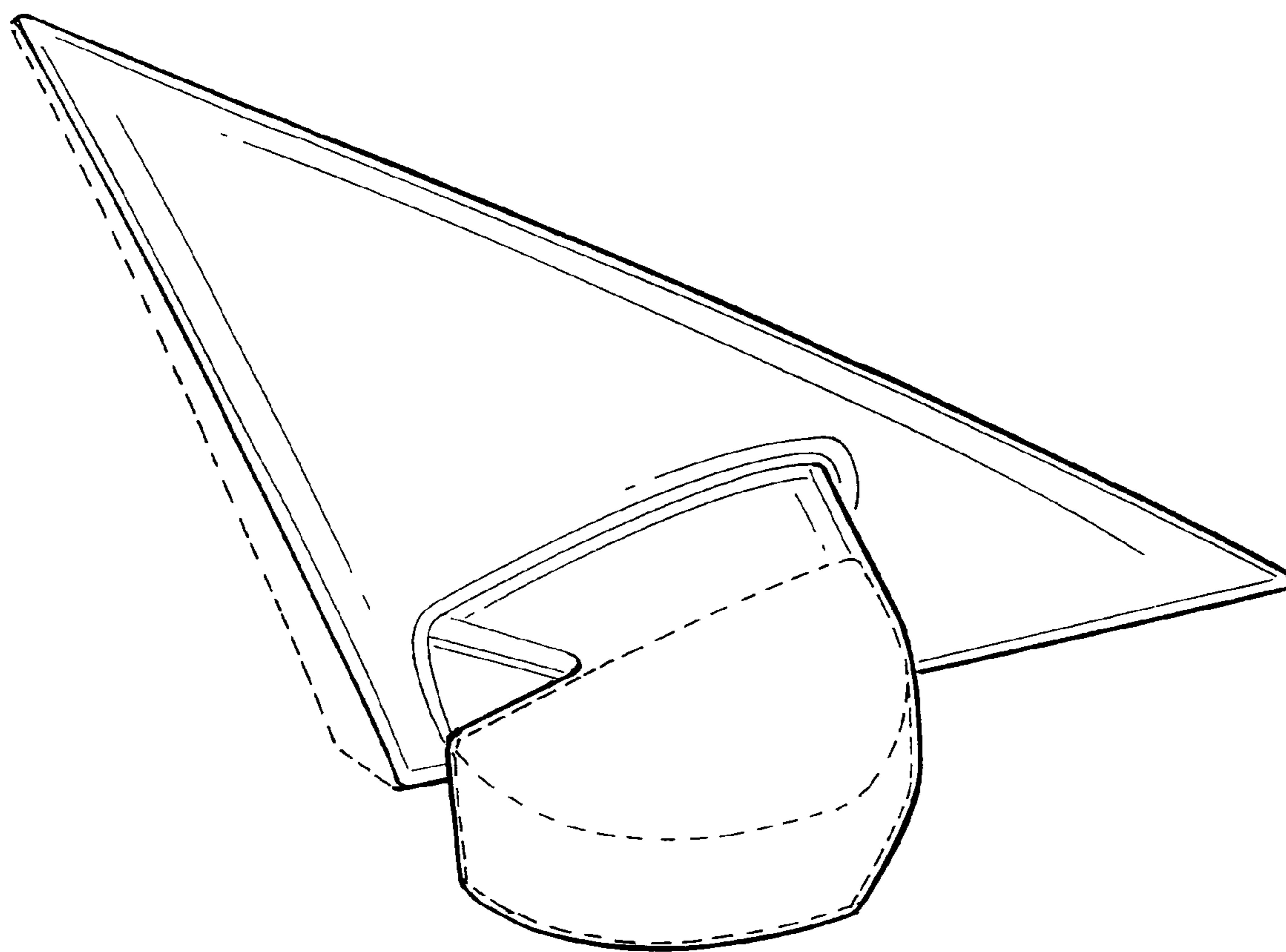

FIG. 7

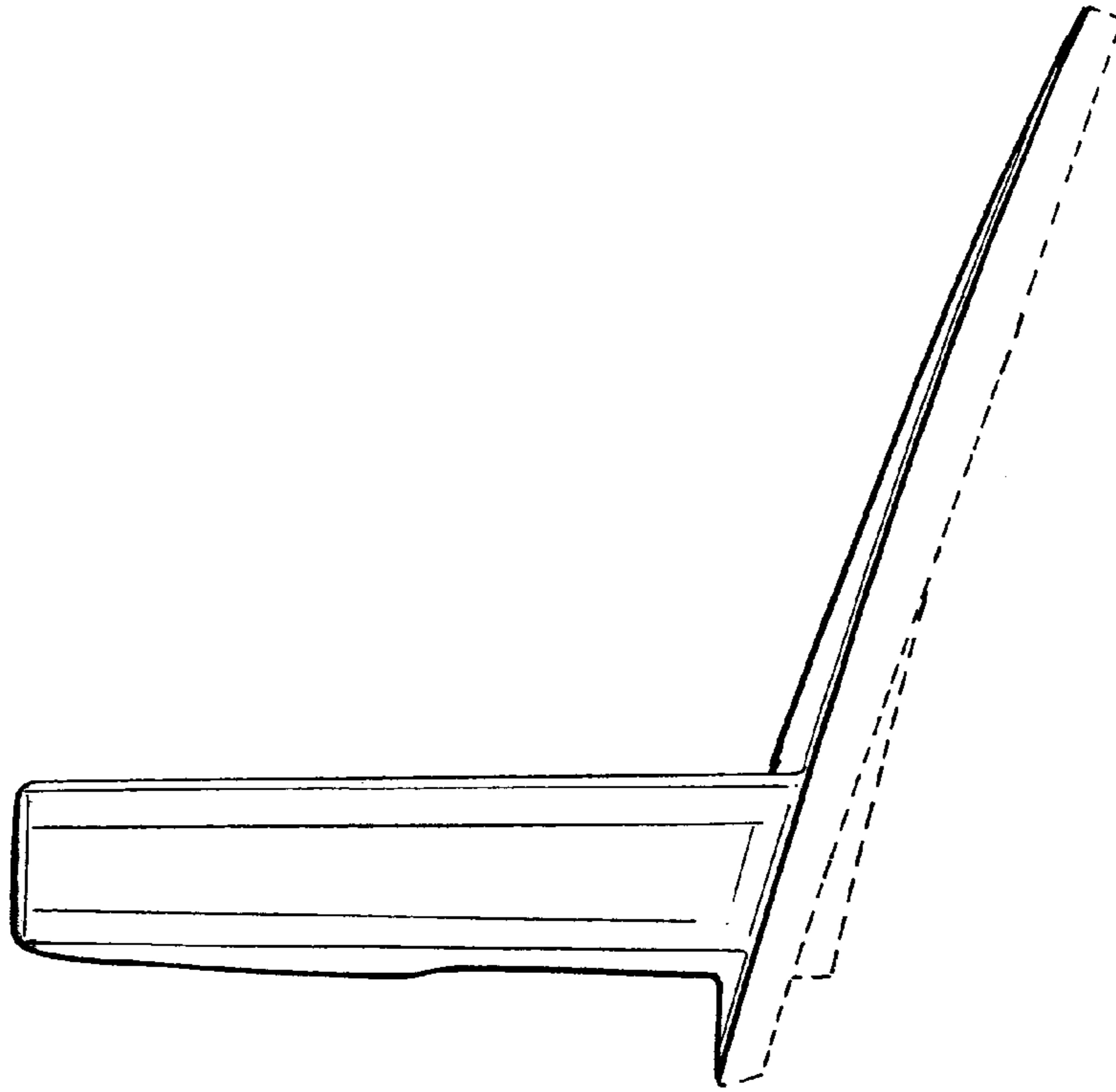

FIG. 8

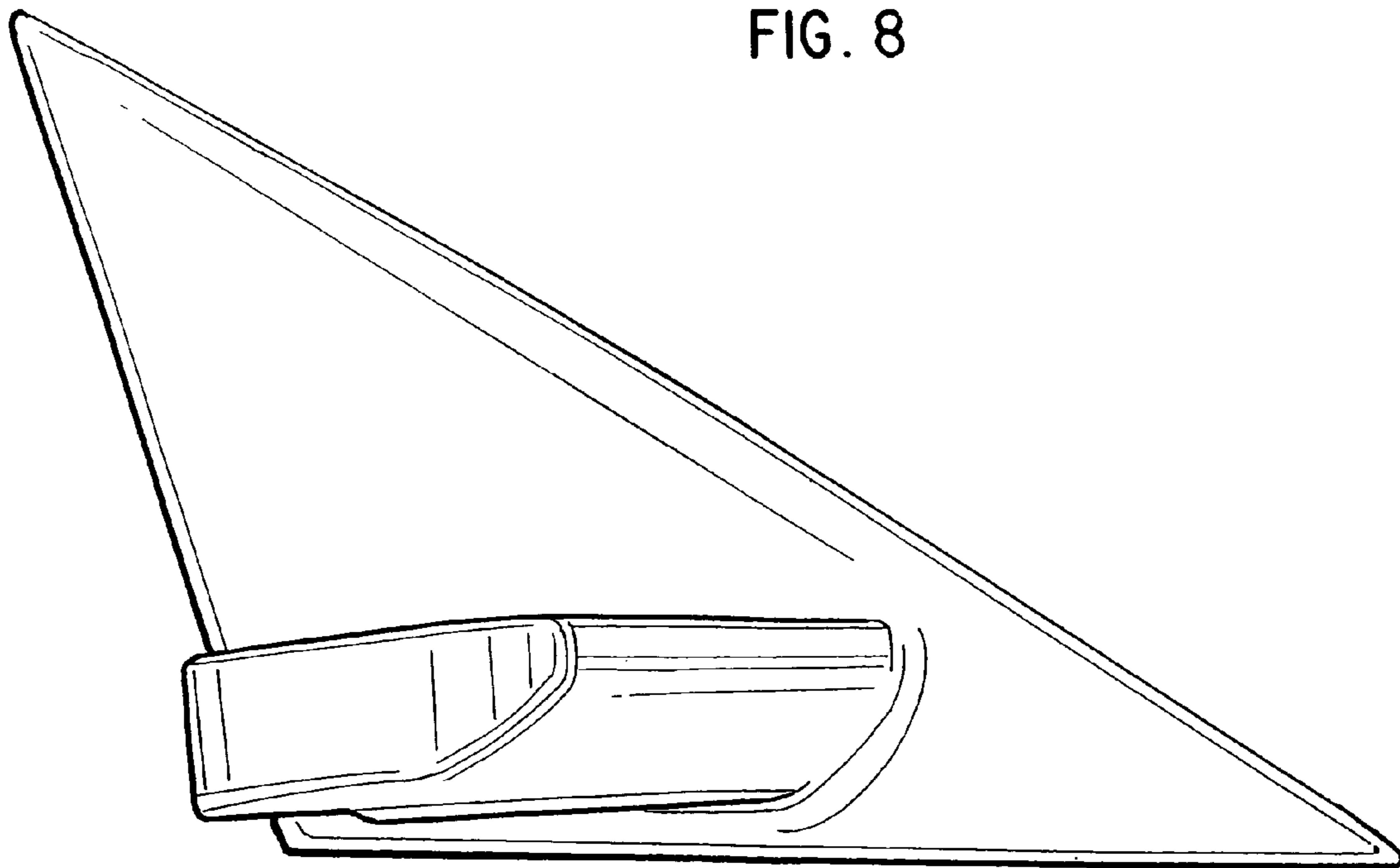

FIG. 9

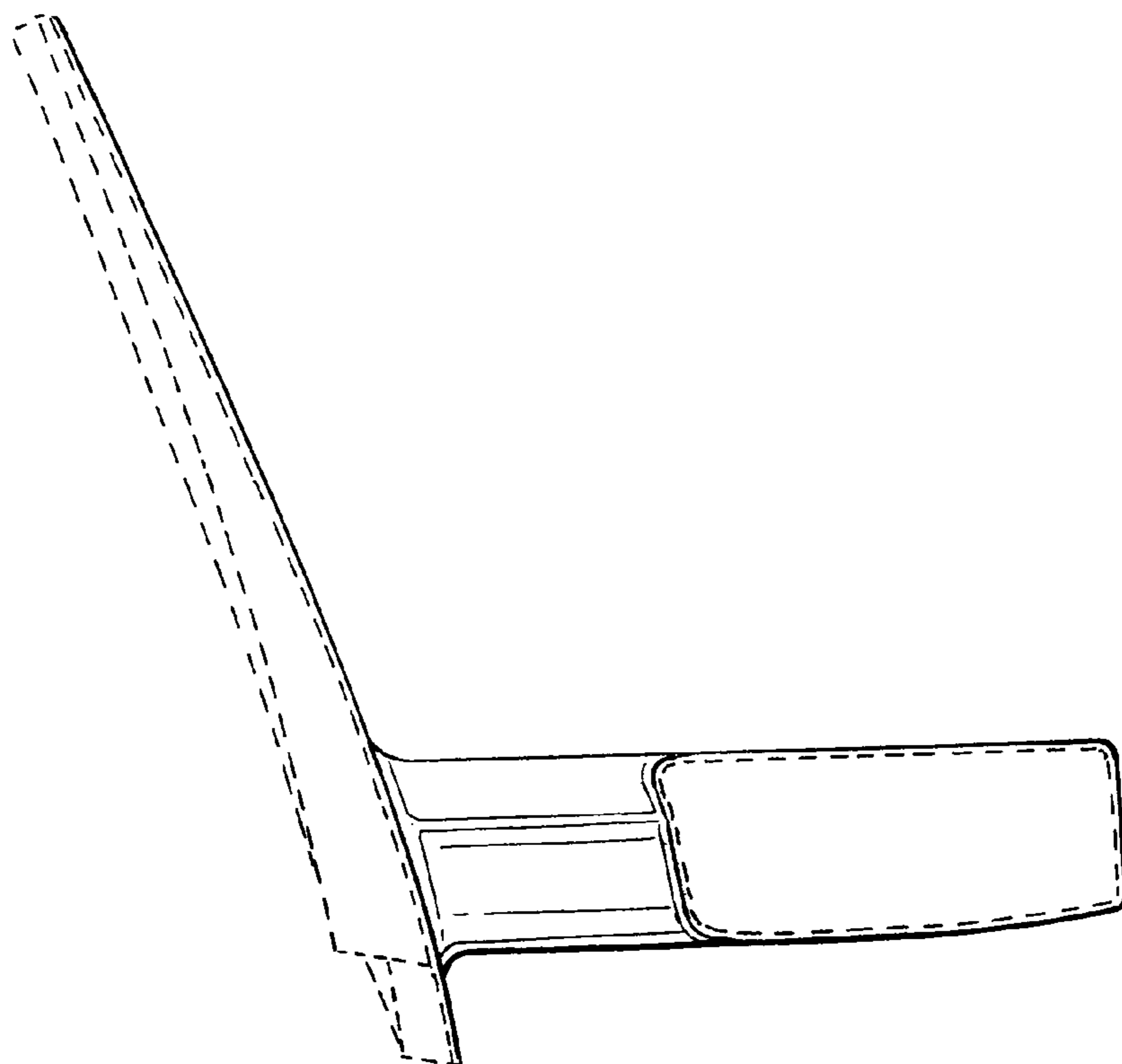

FIG. 10

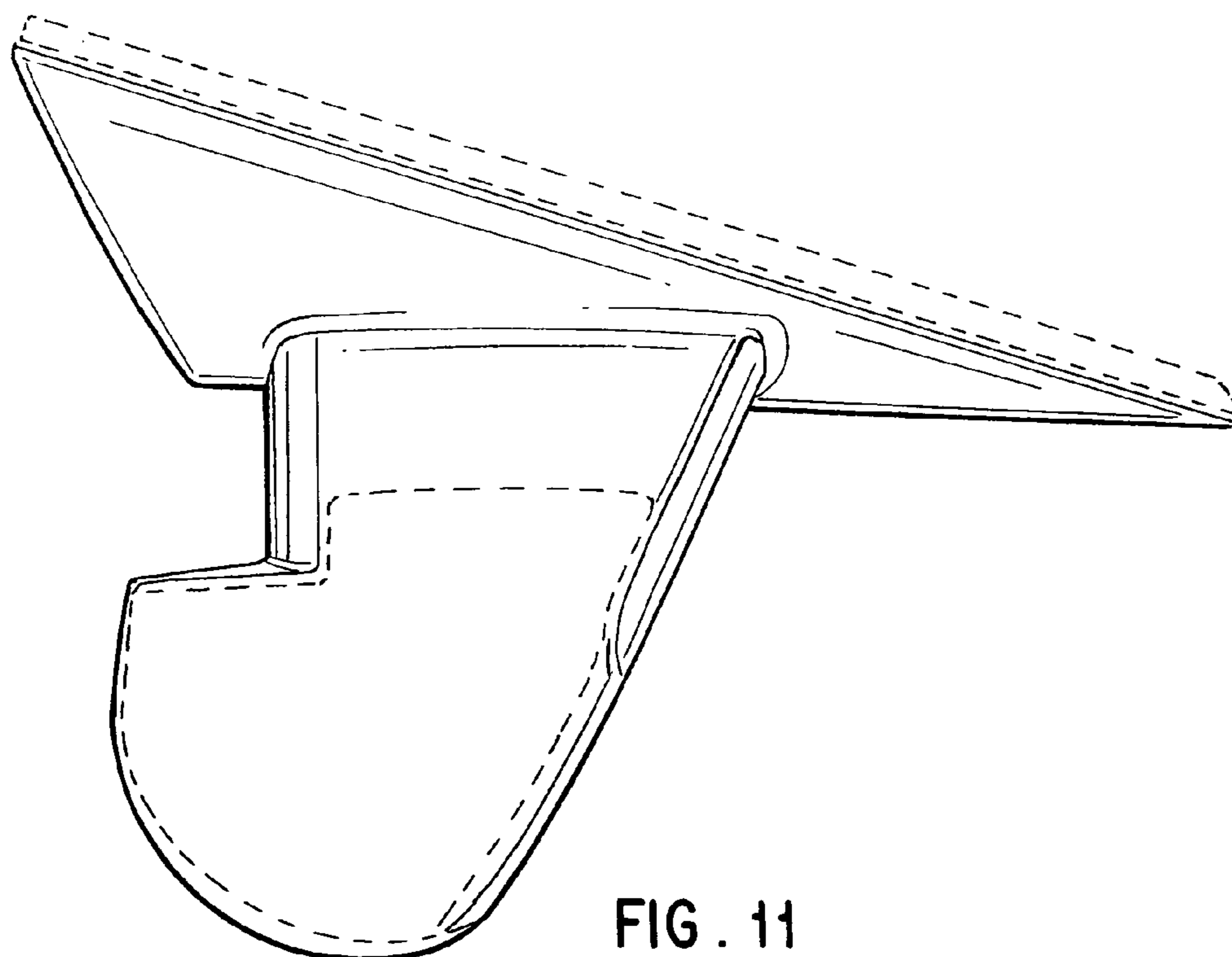

FIG. 11



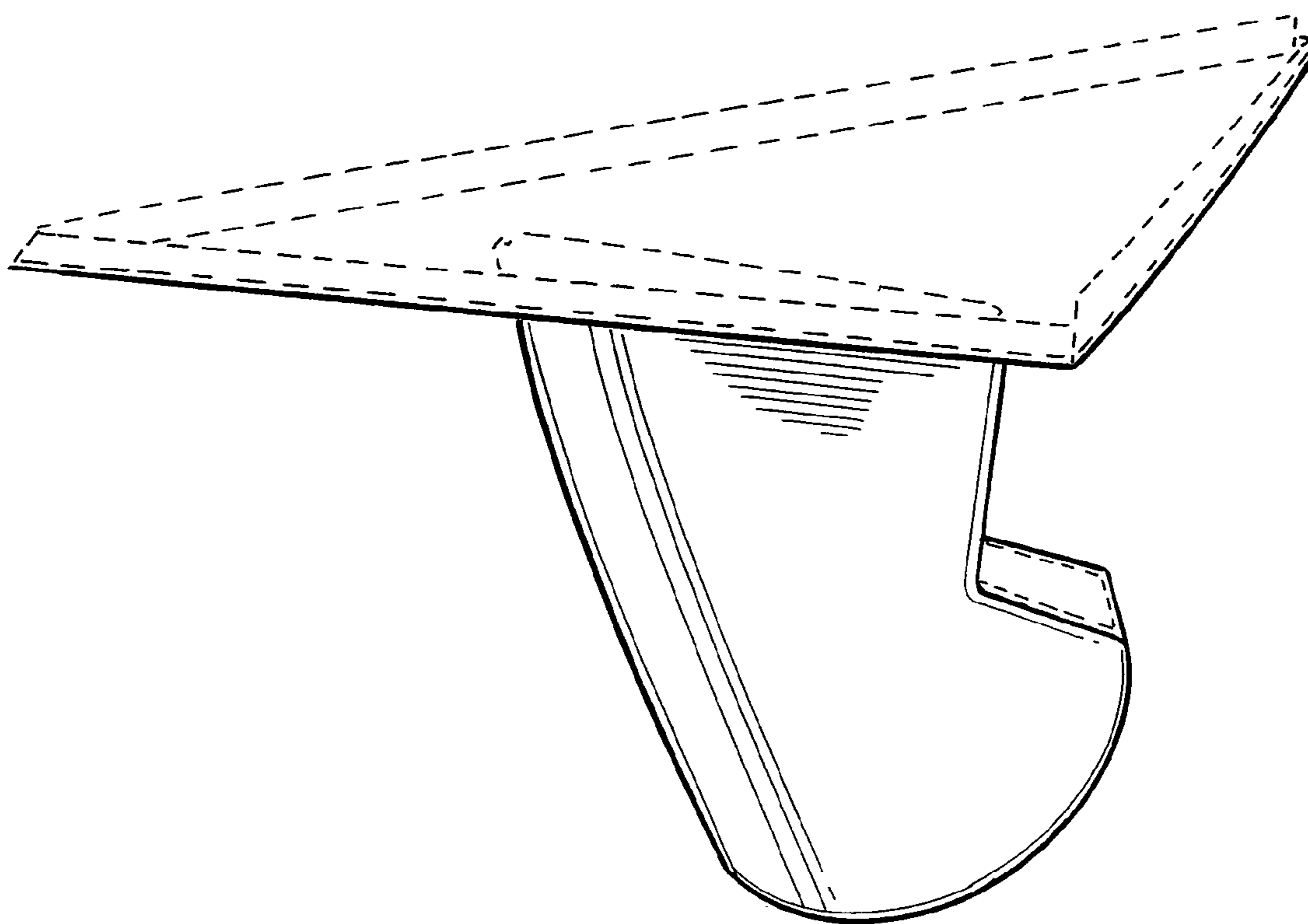

FIG. 12