



US00D575695S

(12) **United States Design Patent**
Opfer et al.

(10) **Patent No.:** **US D575,695 S**

(45) **Date of Patent:** **** Aug. 26, 2008**

(54) **VEHICLE REAR BUMPER**

(75) Inventors: **John G Opfer**, Rochester, MI (US);
Timothy W Anness, Rochester Hills, MI (US)

(73) Assignee: **Chrysler LLC**, Auburn Hills, MI (US)

(**) Term: **14 Years**

(21) Appl. No.: **29/296,192**

(22) Filed: **Oct. 16, 2007**

Related U.S. Application Data

(63) Continuation-in-part of application No. 29/249,266, filed on Sep. 29, 2006, now Pat. No. Des. 553,049.

(51) **LOC (8) Cl.** **12-16**

(52) **U.S. Cl.** **D12/169**

(58) **Field of Classification Search** D12/169,
D12/196, 171, 163, 216, 90-92, 86; 293/102,
293/113, 115, 117, 120; 296/180.1, 180.2
See application file for complete search history.

(56) **References Cited**

U.S. PATENT DOCUMENTS

D490,755 S * 6/2004 Platto et al. D12/169

D516,476 S * 3/2006 Iwanaga et al. D12/169
D553,049 S * 10/2007 Opfer et al. D12/91

* cited by examiner

Primary Examiner—Melody N Brown

(74) *Attorney, Agent, or Firm*—Ralph E. Smith

(57) **CLAIM**

The ornamental design for a vehicle rear bumper, as shown and described.

DESCRIPTION

FIG. 1 is a front perspective view of a vehicle front fascia showing my new design;

FIG. 2 is a rear perspective view thereof;

FIG. 3 is a front view thereof;

FIG. 4 is a rear view thereof;

FIG. 5 is a top plan view thereof;

FIG. 6 is a bottom plan view thereof; and,

FIG. 7 is a side view thereof (the opposite side being a mirror image thereof).

It will be understood that the broken lines presented in the drawings are for illustration only, and do not form a part of the claimed design.

1 Claim, 7 Drawing Sheets

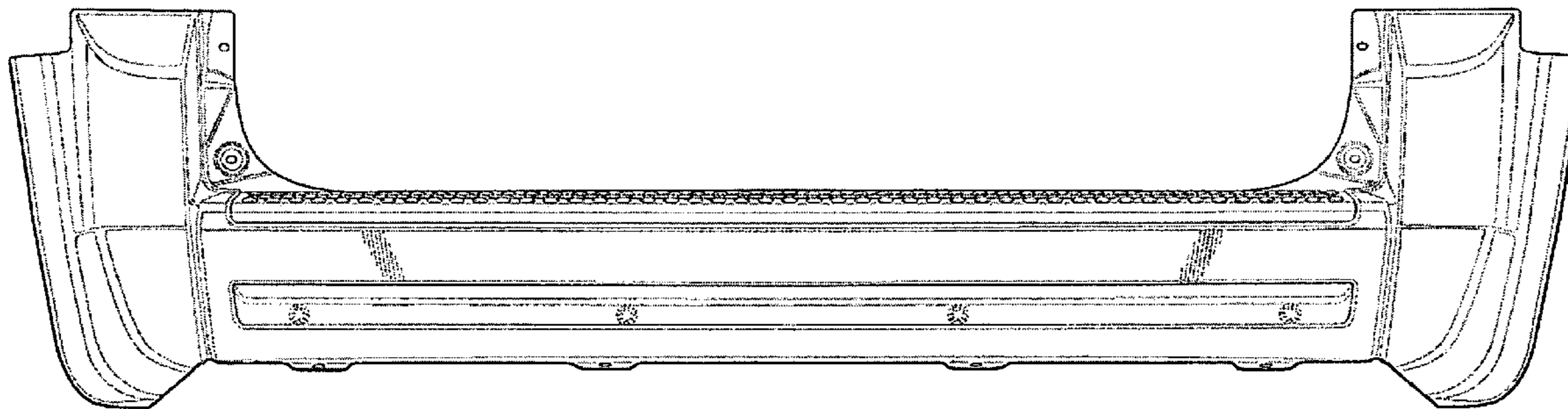
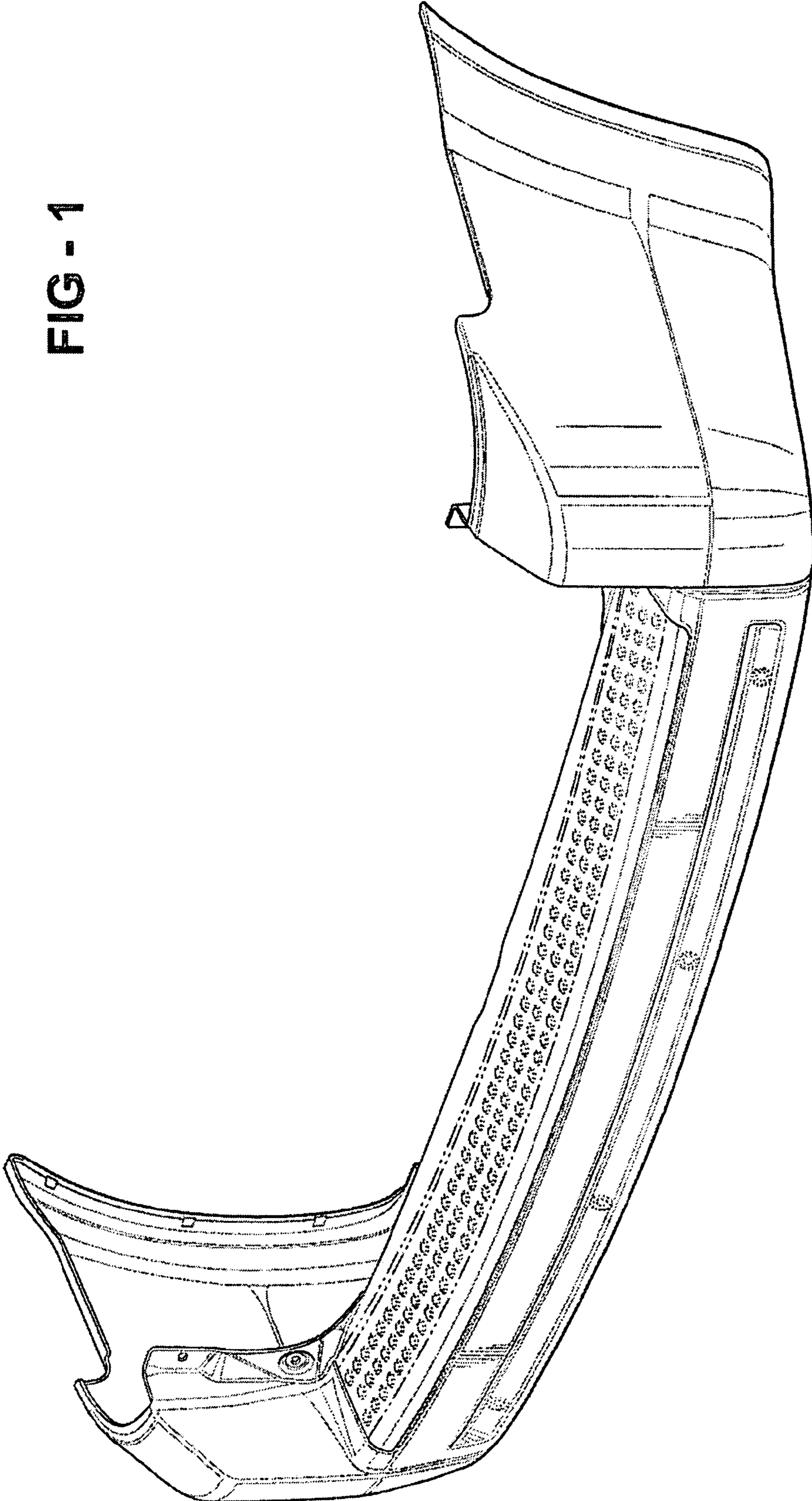

FIG - 1



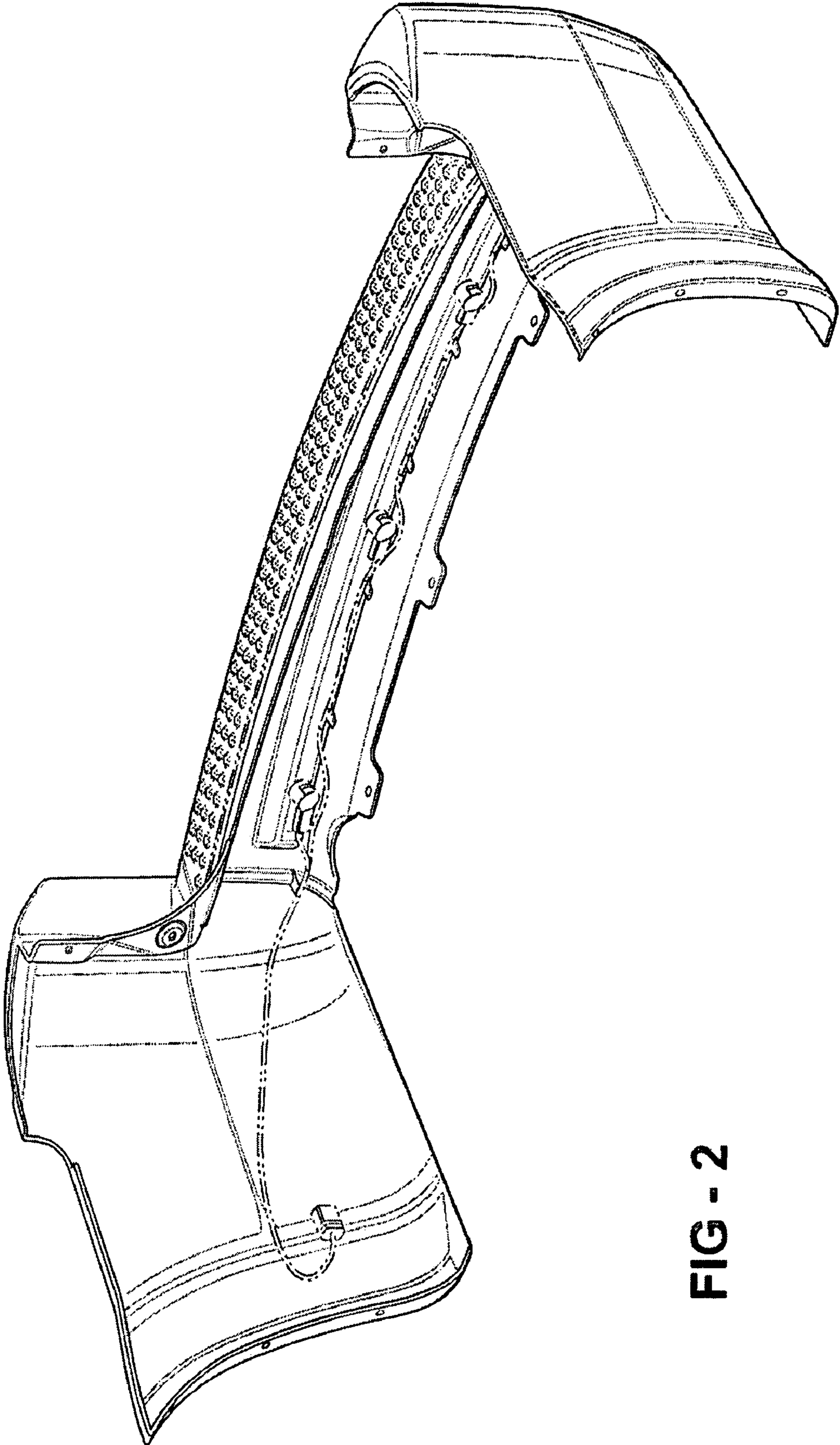

FIG - 2

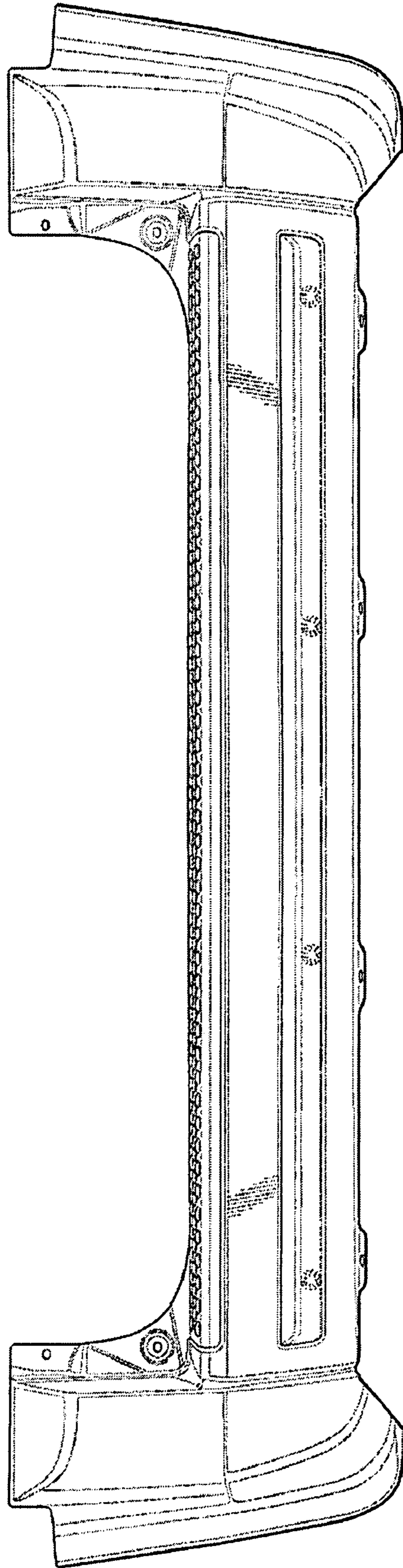

FIG - 3

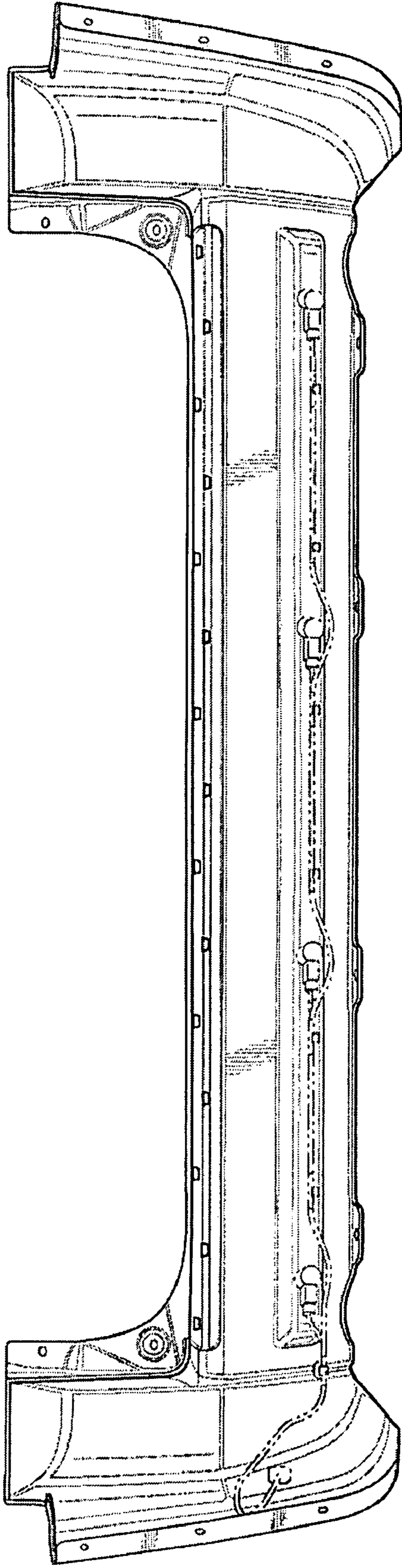

FIG - 4

FIG - 5

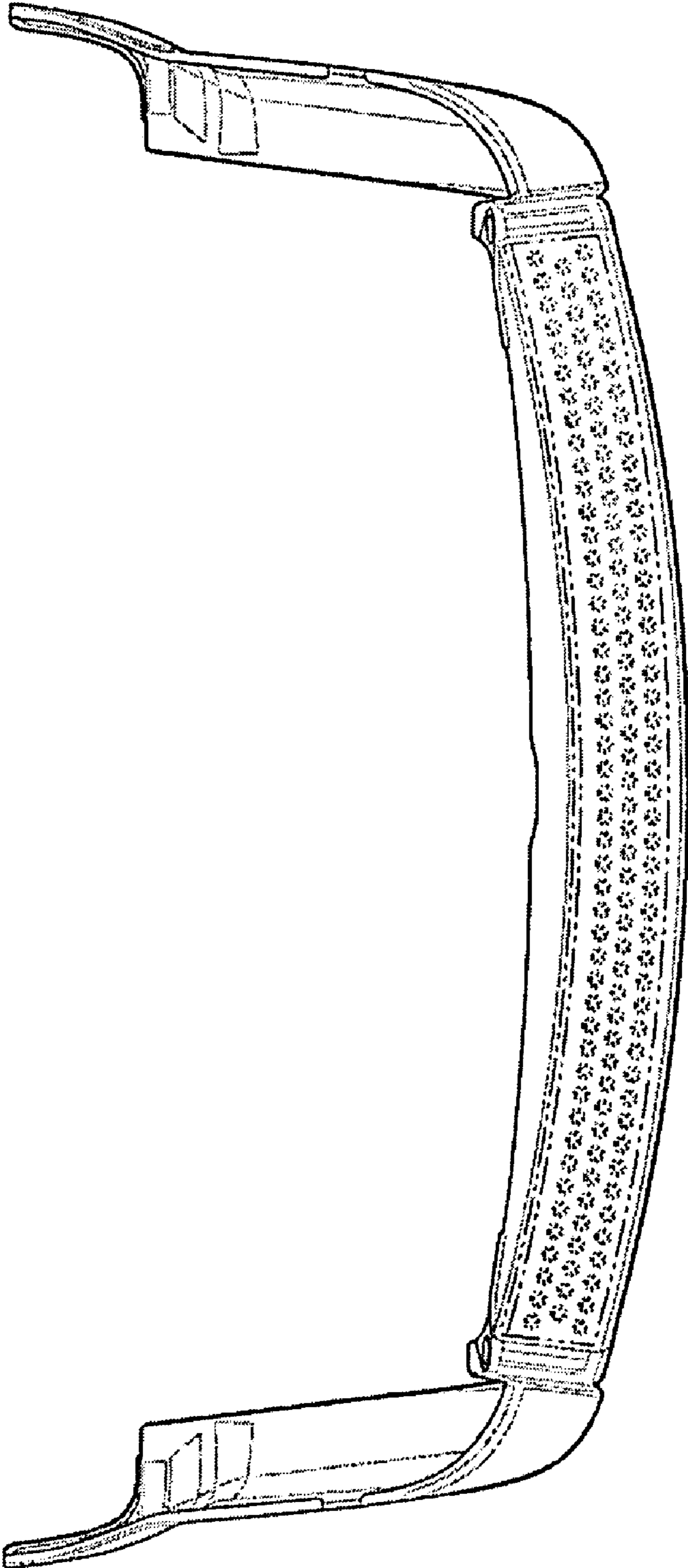
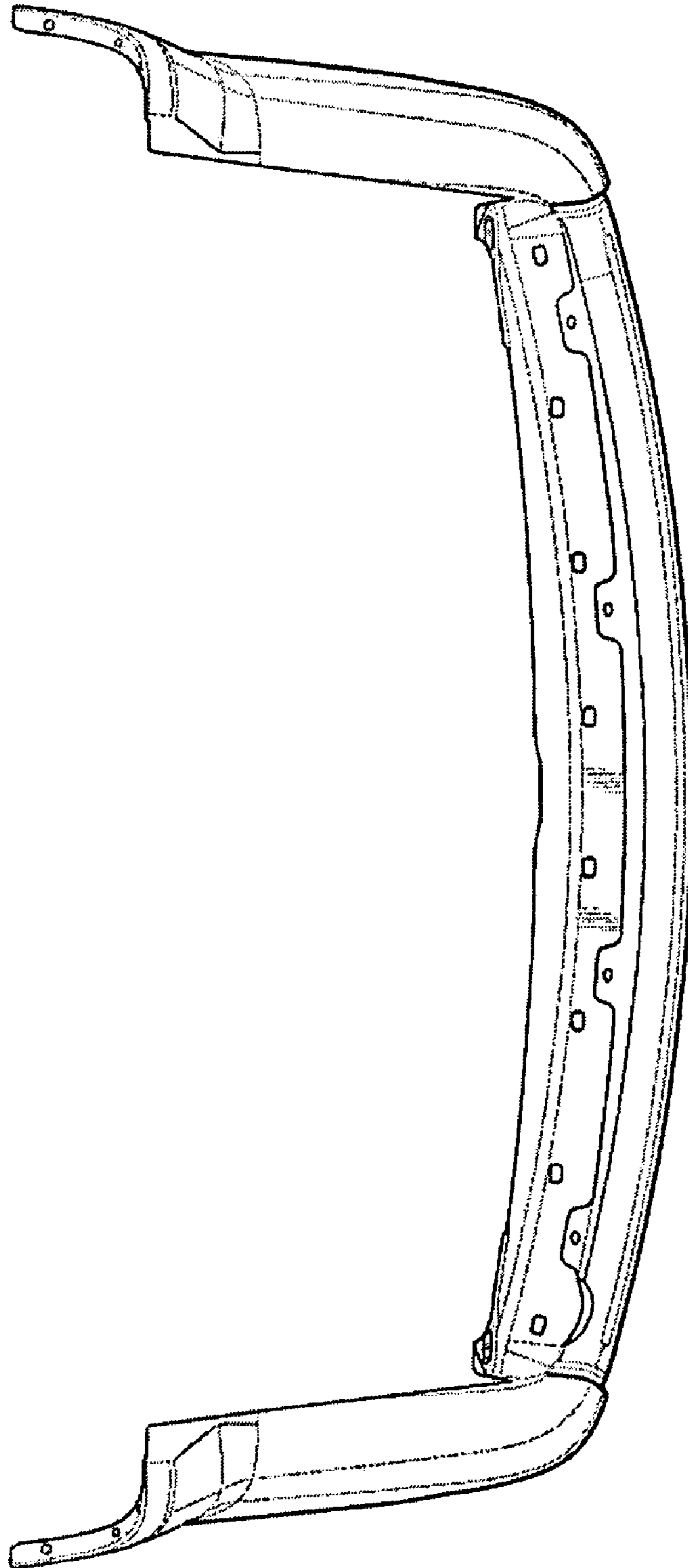

FIG - 6



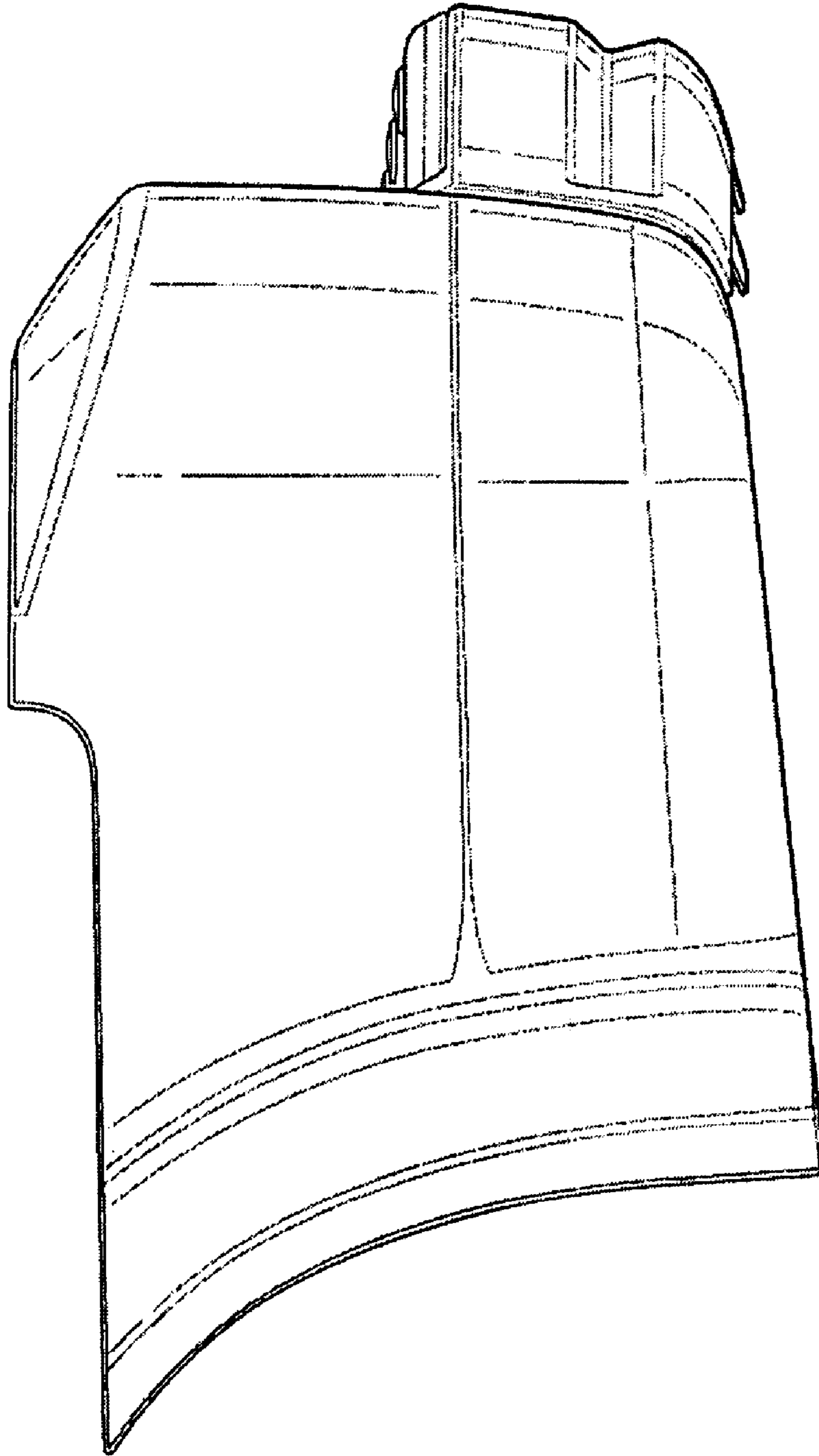

FIG - 7