



US00D575581S

(12) **United States Design Patent**  
**Harris**

(10) **Patent No.:** **US D575,581 S**  
(45) **Date of Patent:** **\*\* Aug. 26, 2008**

(54) **BASE FOR BOWL**

(76) Inventor: **Charles E. Harris**, 104-6 Moo 17  
Tambol Mae Fah Luang, P.O. Box 18,  
Mae Fah Luang District, Chiang Rai  
(TH) 57240

(\*\*) Term: **14 Years**

(21) Appl. No.: **29/298,671**

(22) Filed: **Dec. 10, 2007**

(51) **LOC (8) Cl.** ..... **07-01**

(52) **U.S. Cl.** ..... **D7/396.6; D7/396.1; D7/624.1;**  
D7/392.1

(58) **Field of Classification Search** ..... D7/396.6,  
D7/396.1, 387, 624.1, 550.1, 553.6, 553.7,  
D7/554.2, 554.4, 558, 584, 392.1, 391, 540;  
D9/354, 454; D30/121, 129; D23/379; D6/491,  
D6/512; 99/467; 150/155; 215/379; 220/493.03,  
220/573.1, 574, 23.83, 915.1, 306, 352, 356  
See application file for complete search history.

(56) **References Cited**

**U.S. PATENT DOCUMENTS**

2,053,949	A *	9/1936	Emery	.....	220/574
D114,551	S *	5/1939	Morgan	.....	D7/624.1
2,501,983	A *	3/1950	Zoia	.....	220/799
3,266,533	A *	8/1966	McHale	.....	141/364
3,684,633	A *	8/1972	Haase	.....	428/66.7
3,831,209	A *	8/1974	Clingman	.....	441/136

D281,758	S *	12/1985	Trombly	.....	D7/392.1
D313,487	S *	1/1991	Conner	.....	D30/129
D417,584	S *	12/1999	Lillelund et al.	.....	D7/392.1
6,561,375	B1 *	5/2003	Nagy	.....	220/574
D563,785	S *	3/2008	Maki et al.	.....	D9/454
D564,710	S *	3/2008	Modi et al.	.....	D30/129

\* cited by examiner

*Primary Examiner*—Gary D. Watson  
*Assistant Examiner*—Cynthia Underwood  
(74) *Attorney, Agent, or Firm*—Nixon Peabody LLP

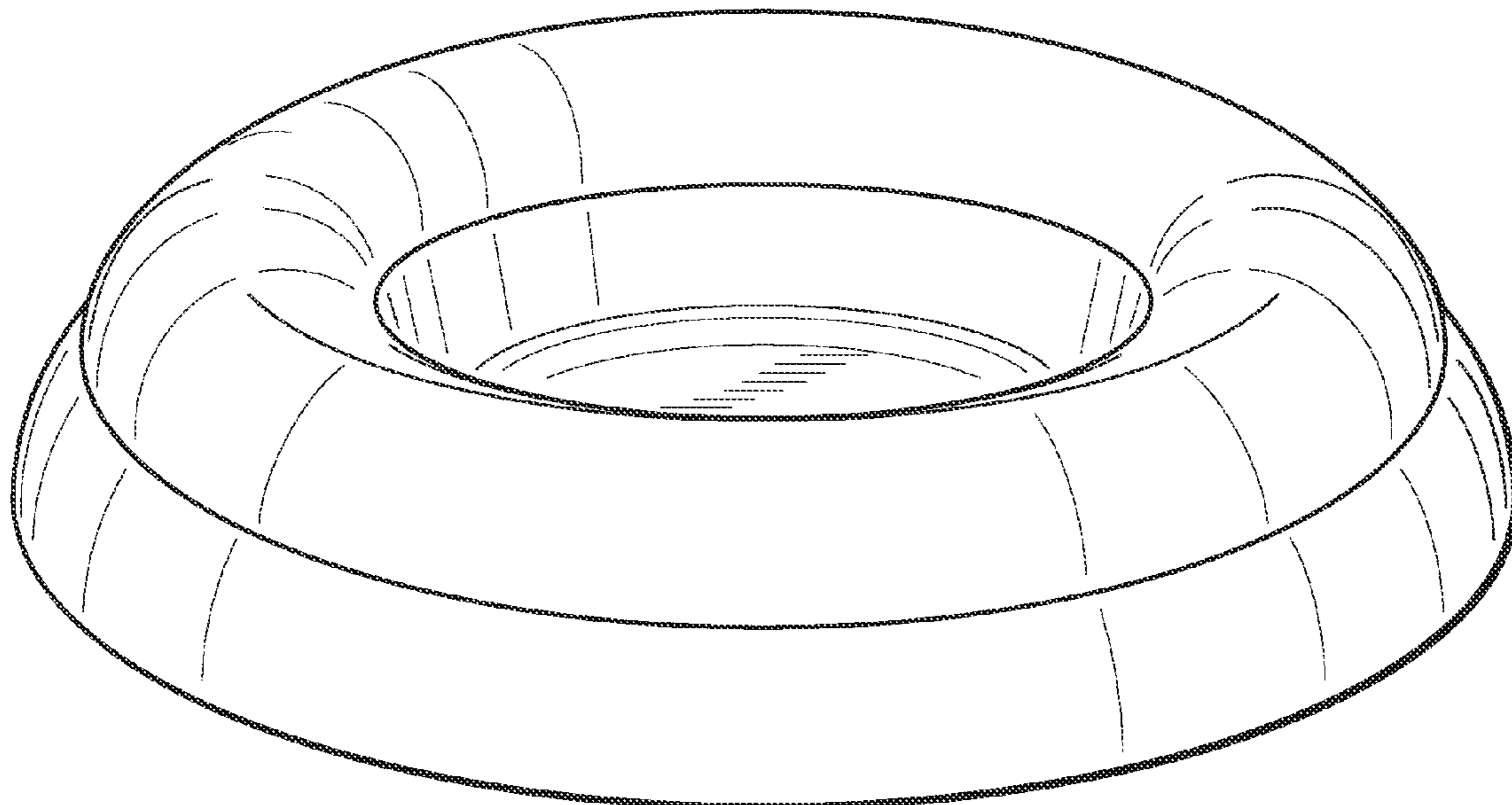
(57) **CLAIM**

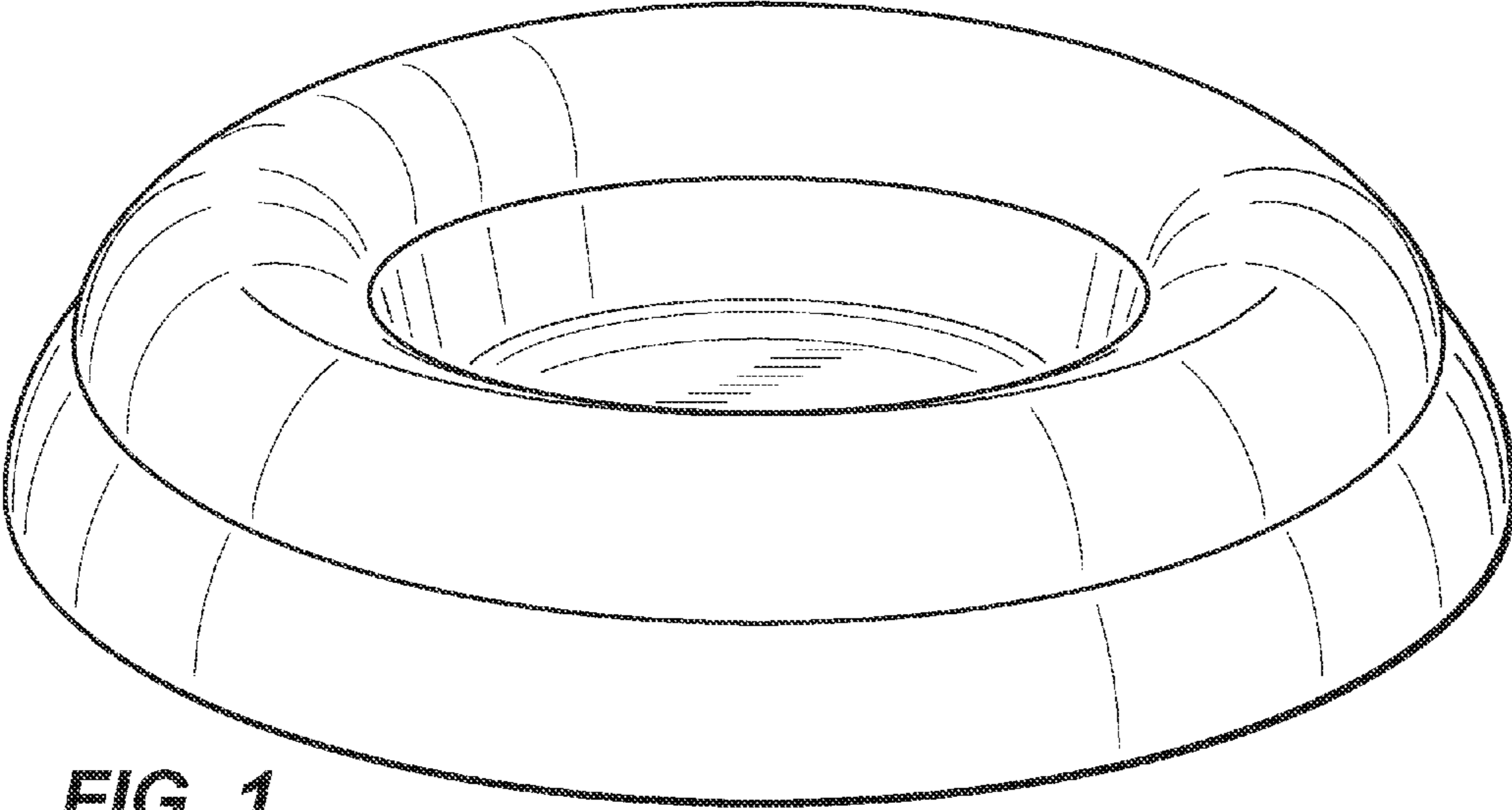
The ornamental design for a base for bowl, as shown and described.

**DESCRIPTION**

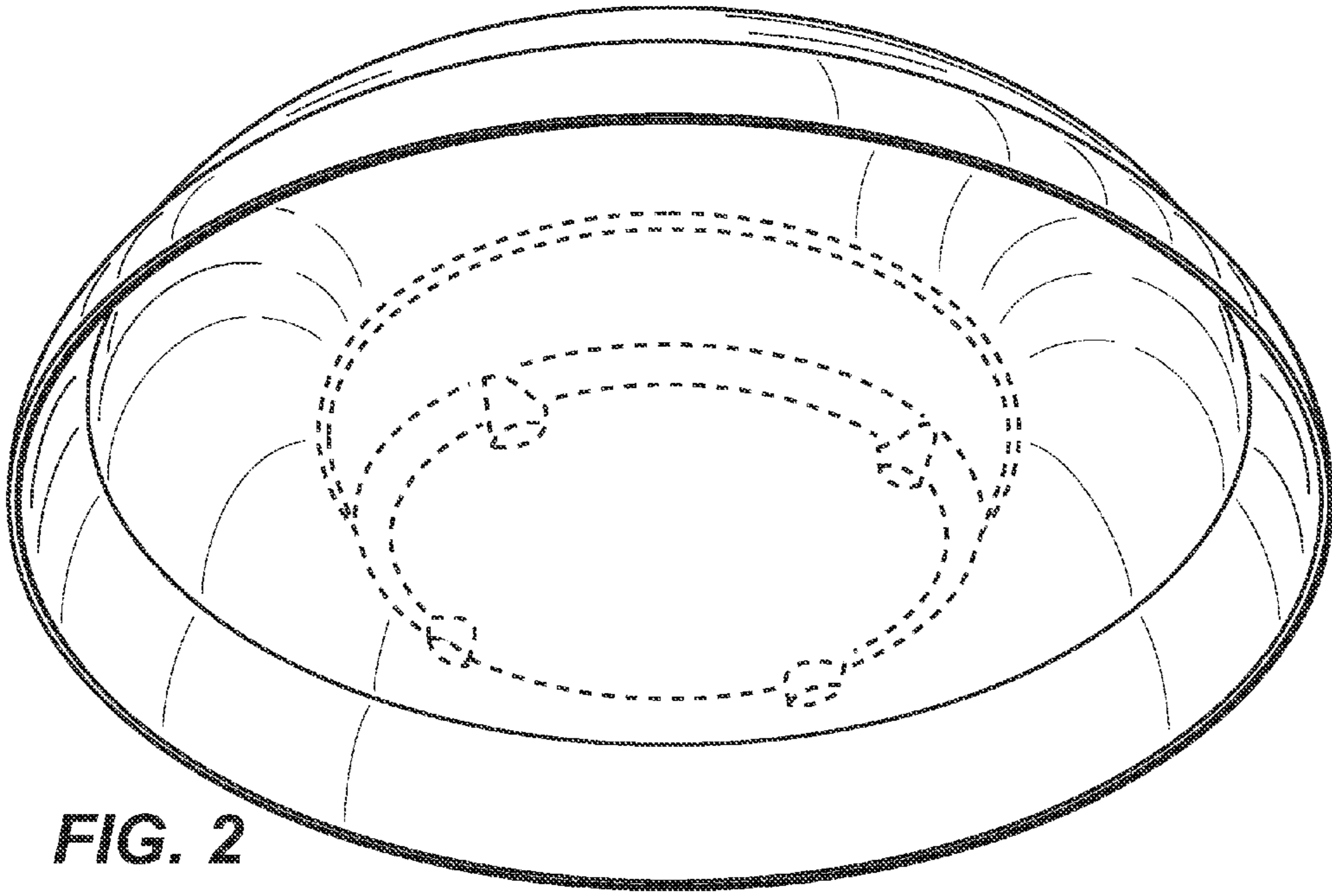
FIG. 1 is a top perspective view of a base for bowl;  
FIG. 2 is a bottom perspective view of the base for bowl shown in FIG. 1;  
FIG. 3 is a side view of the base for bowl shown in FIG. 1;  
FIG. 4 is a top view of the base for bowl shown in FIG. 1; and,  
FIG. 5 is a bottom view of the base for bowl shown in FIG. 1.  
In FIGS. 2, 3 and 5, the support structure and feet on the underside of the base are shown in broken line and are for illustrative purposes only. They form no part of the claimed design.

**1 Claim, 3 Drawing Sheets**

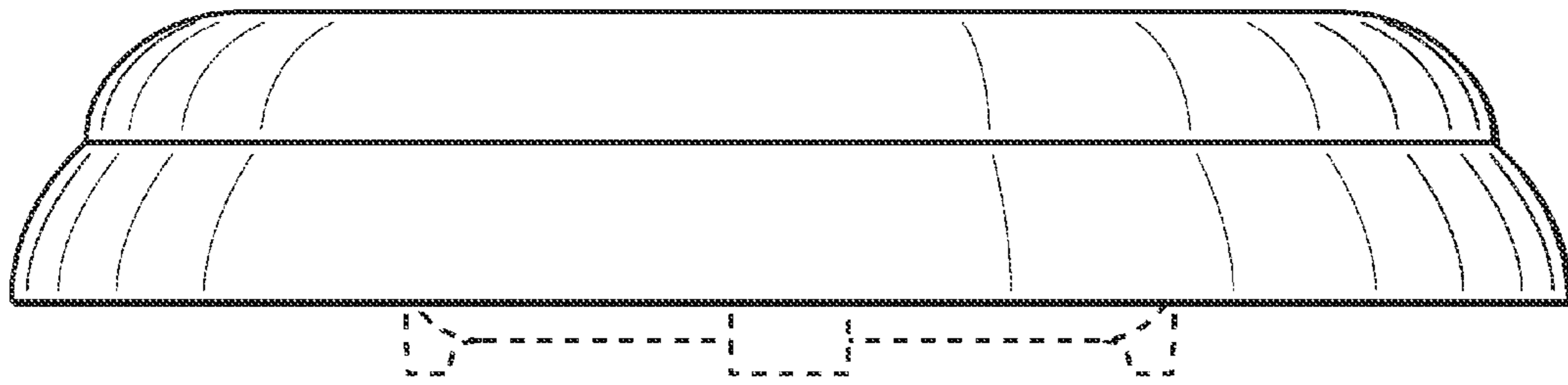




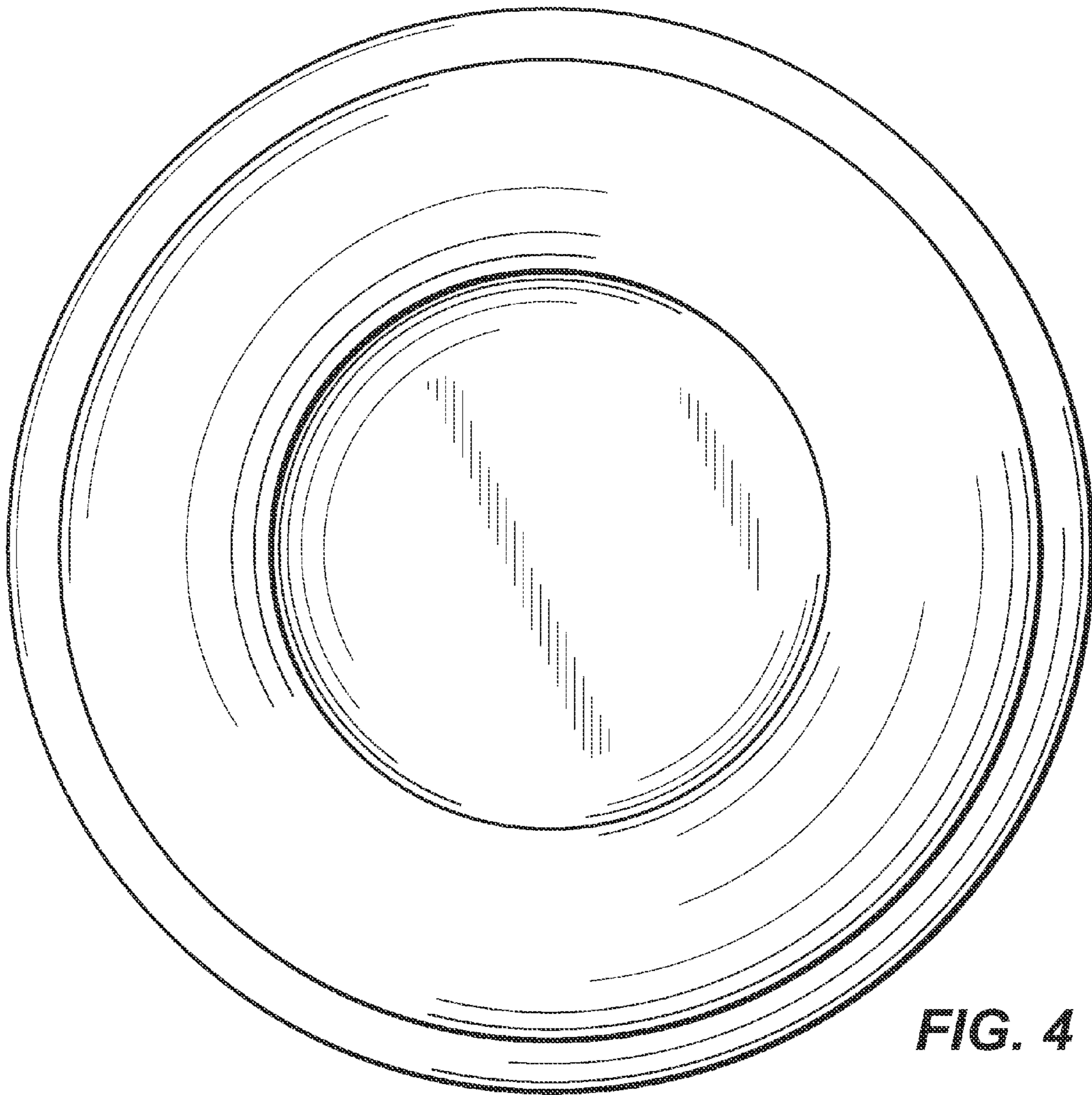
**FIG. 1**



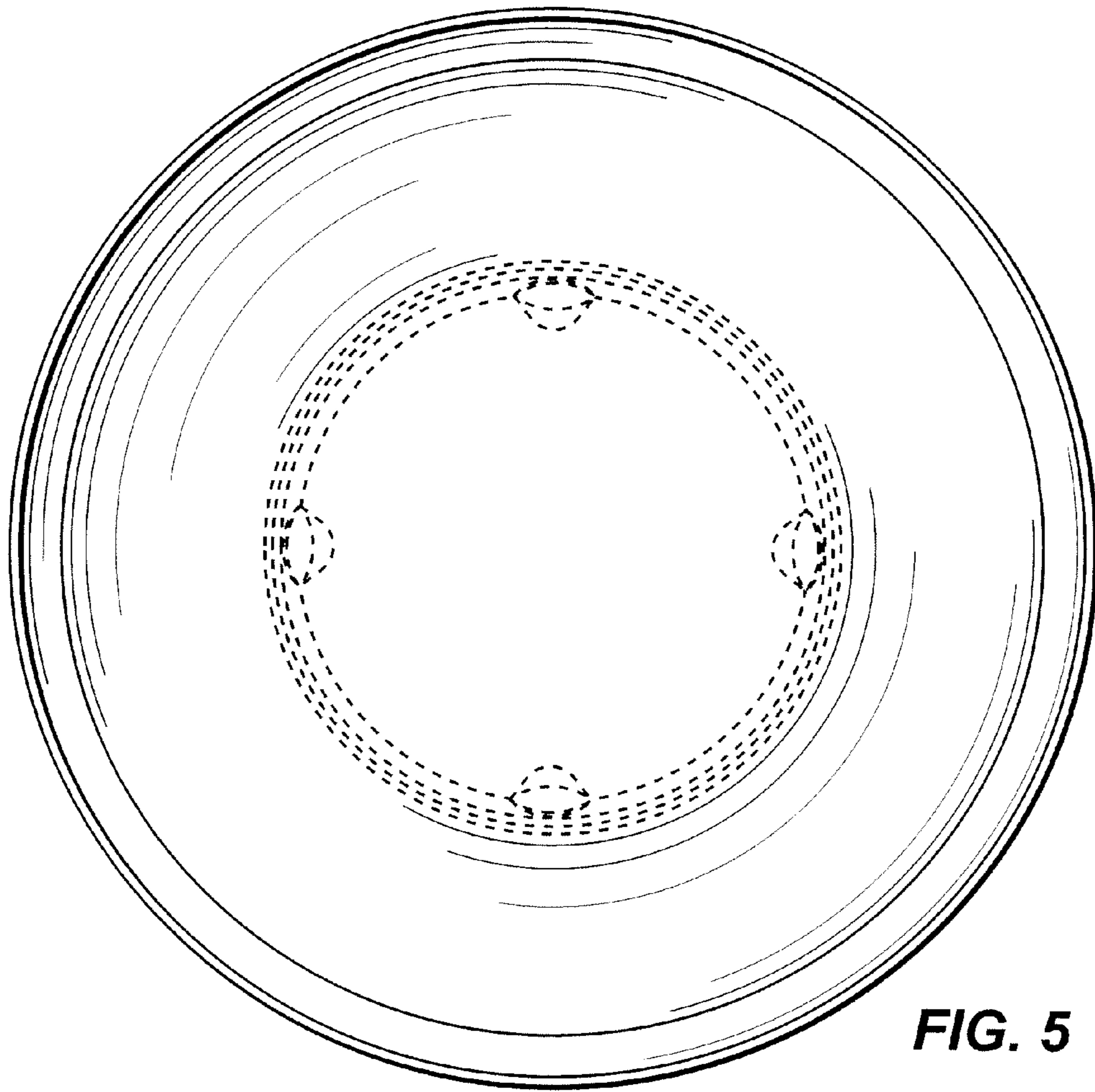
**FIG. 2**



**FIG. 3**



**FIG. 4**



**FIG. 5**