



US00D575350S

(12) **United States Design Patent**  
**Ashida et al.**

(10) **Patent No.:** **US D575,350 S**  
(45) **Date of Patent:** **\*\* Aug. 19, 2008**

(54) **BASE STAND FOR ELECTRONIC GAME MACHINE**

(75) Inventors: **Kenichiro Ashida**, Kyoto (JP); **Junji Takamoto**, Kyoto (JP); **Yoshitomo Goto**, Kyoto (JP); **Masato Ibuki**, Kyoto (JP); **Shinji Yamamoto**, Kyoto (JP); **Fumiyoshi Suetake**, Kyoto (JP); **Akiko Suga**, Kyoto (JP)

(73) Assignee: **Nintendo Co., Ltd.**, Kyoto (JP)

(\*\*) Term: **14 Years**

(21) Appl. No.: **29/268,259**

(22) Filed: **Nov. 2, 2006**

(30) **Foreign Application Priority Data**

May 2, 2006 (JP) ..... 2006-011517

(51) **LOC (8) Cl.** ..... **21-01**

(52) **U.S. Cl.** ..... **D21/333; D14/434**

(58) **Field of Classification Search** ..... D21/324, D21/328, 333; D14/433, 434, 447, 356; 273/148 B, 148 R; 463/46, 47; 379/454, 379/455; 361/679, 686; 345/156-161  
See application file for complete search history.

(56) **References Cited**

**U.S. PATENT DOCUMENTS**

4,530,504	A *	7/1985	Long, Jr.	.....	273/148 B
5,209,478	A *	5/1993	Simpson	.....	273/148 B
D376,585	S *	12/1996	Wathen et al.	.....	D14/434
D462,398	S *	9/2002	Hussaini et al.	.....	D21/333
6,647,248	B1 *	11/2003	Ortscheid et al.	.....	455/575.1
6,735,309	B1 *	5/2004	Lemanski et al.	.....	379/454
D494,634	S *	8/2004	Soga	.....	D21/333
D495,336	S *	8/2004	Andre et al.	.....	D14/434
6,912,125	B2 *	6/2005	Weng	.....	361/686
D540,328	S *	4/2007	Hussaini et al.	.....	D14/434
D540,802	S *	4/2007	Hussaini et al.	.....	D14/434
D543,246	S *	5/2007	Ashida et al.	.....	D21/333

\* cited by examiner

*Primary Examiner*—Prabhakar Deshmukh

(74) *Attorney, Agent, or Firm*—Nixon & Vanderhye, PC

(57) **CLAIM**

The ornamental design for a base stand for electronic game machine, as shown and described.

**DESCRIPTION**

FIG. 1 is a front, top and left perspective view of a base stand for electronic game machine showing a first embodiment of our new design;

FIG. 2 is a rear, bottom and right perspective view thereof;

FIG. 3 is a front view thereof;

FIG. 4 is a rear view thereof;

FIG. 5 is a left side view thereof;

FIG. 6 is a right side view thereof;

FIG. 7 is a top plan view thereof;

FIG. 8 is a bottom plan view thereof; and

FIG. 9 is a reference perspective view showing a state that an electronic game machine is attached onto this base stand.

FIG. 10 is a front, top and left perspective view of a base stand for electronic game machine showing a second embodiment of our new design;

FIG. 11 is a rear, bottom and right perspective view thereof;

FIG. 12 is a front view thereof;

FIG. 13 is a rear view thereof;

FIG. 14 is a left side view thereof;

FIG. 15 is a right side view thereof;

FIG. 16 is a top plan view thereof; and,

FIG. 17 is a bottom plan view thereof.

The broken line showing of an electronic game machine in FIG. 9 is for illustrative purpose only and forms no part of the claimed design.

**1 Claim, 5 Drawing Sheets**

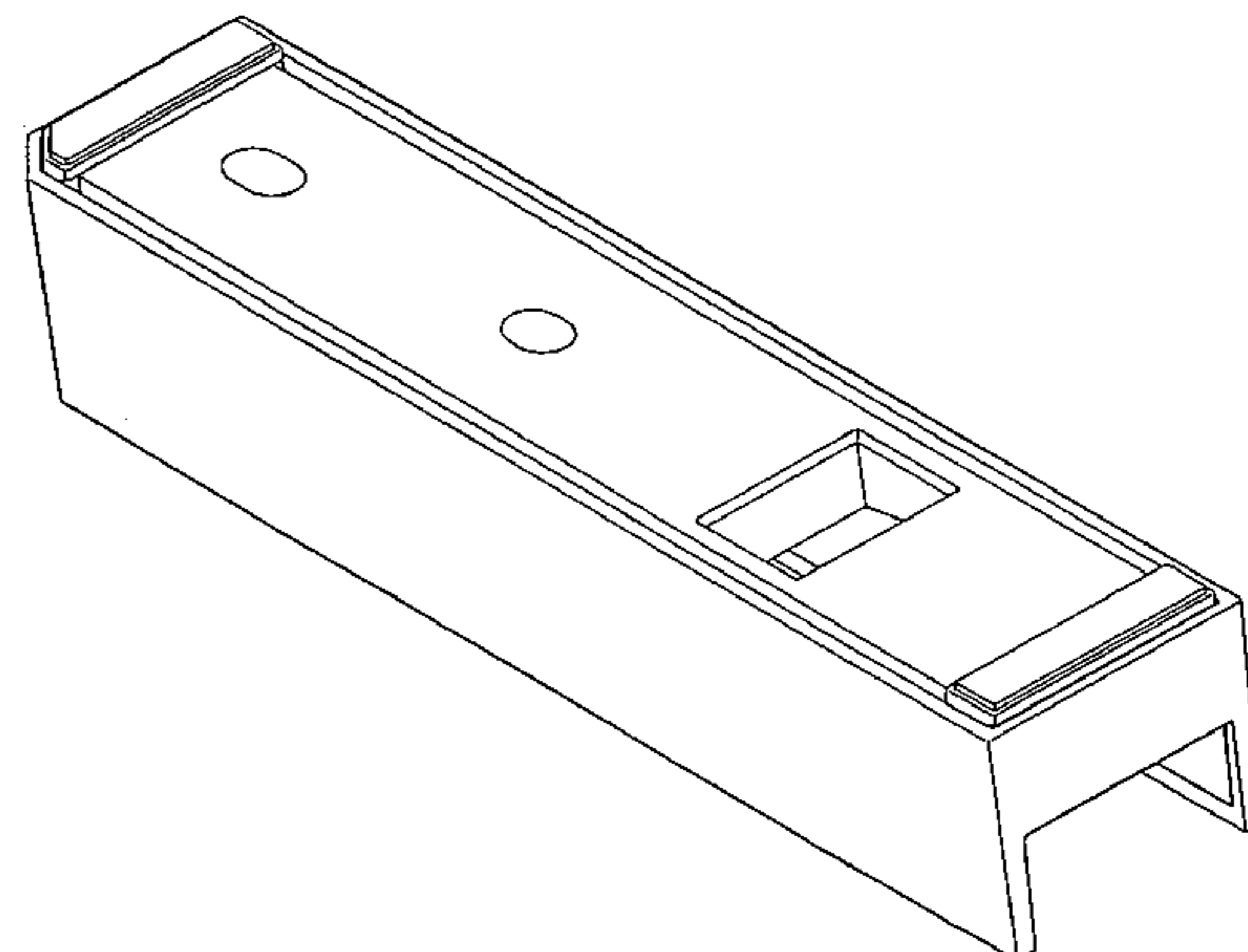
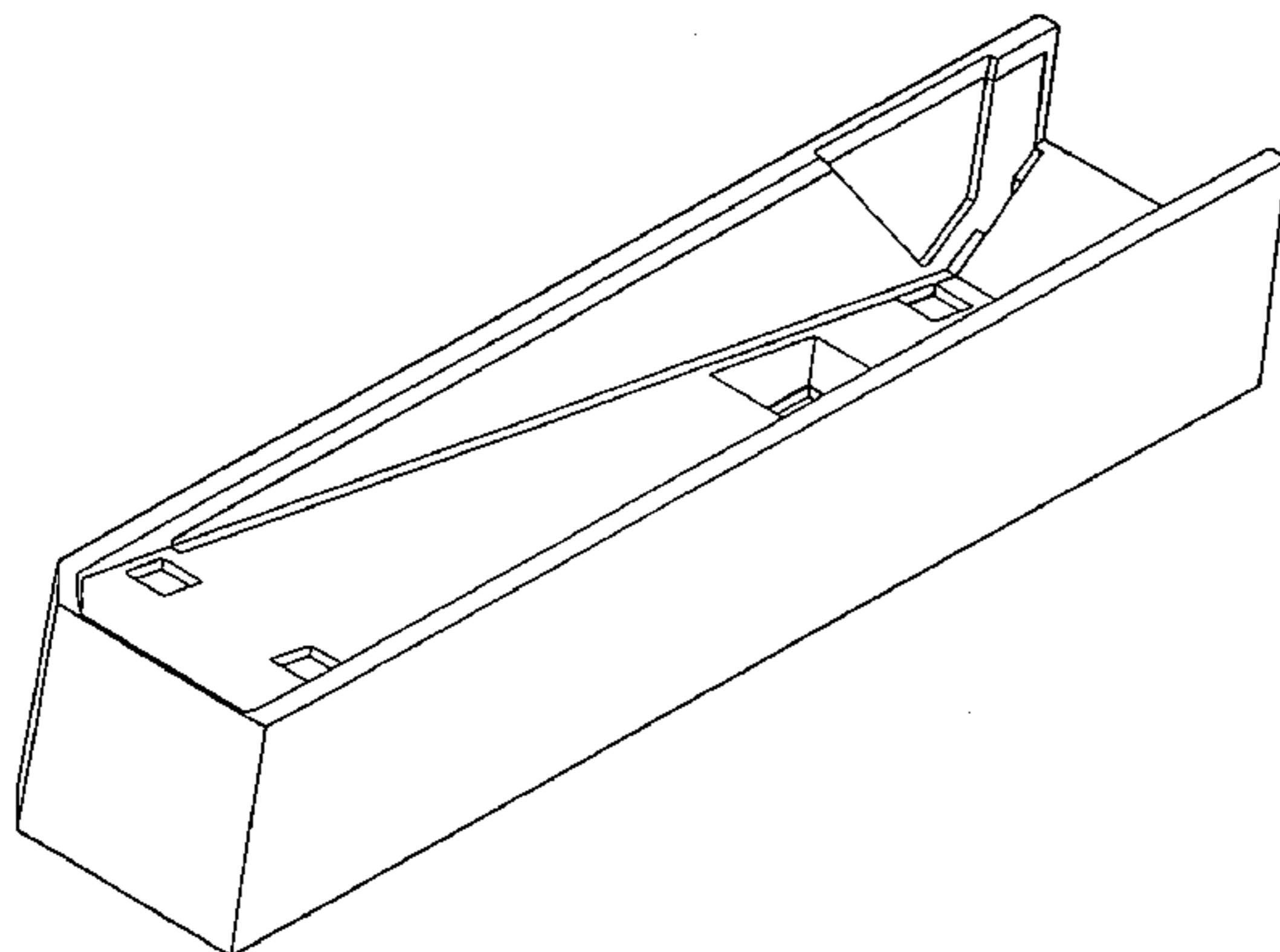

FIG. 1

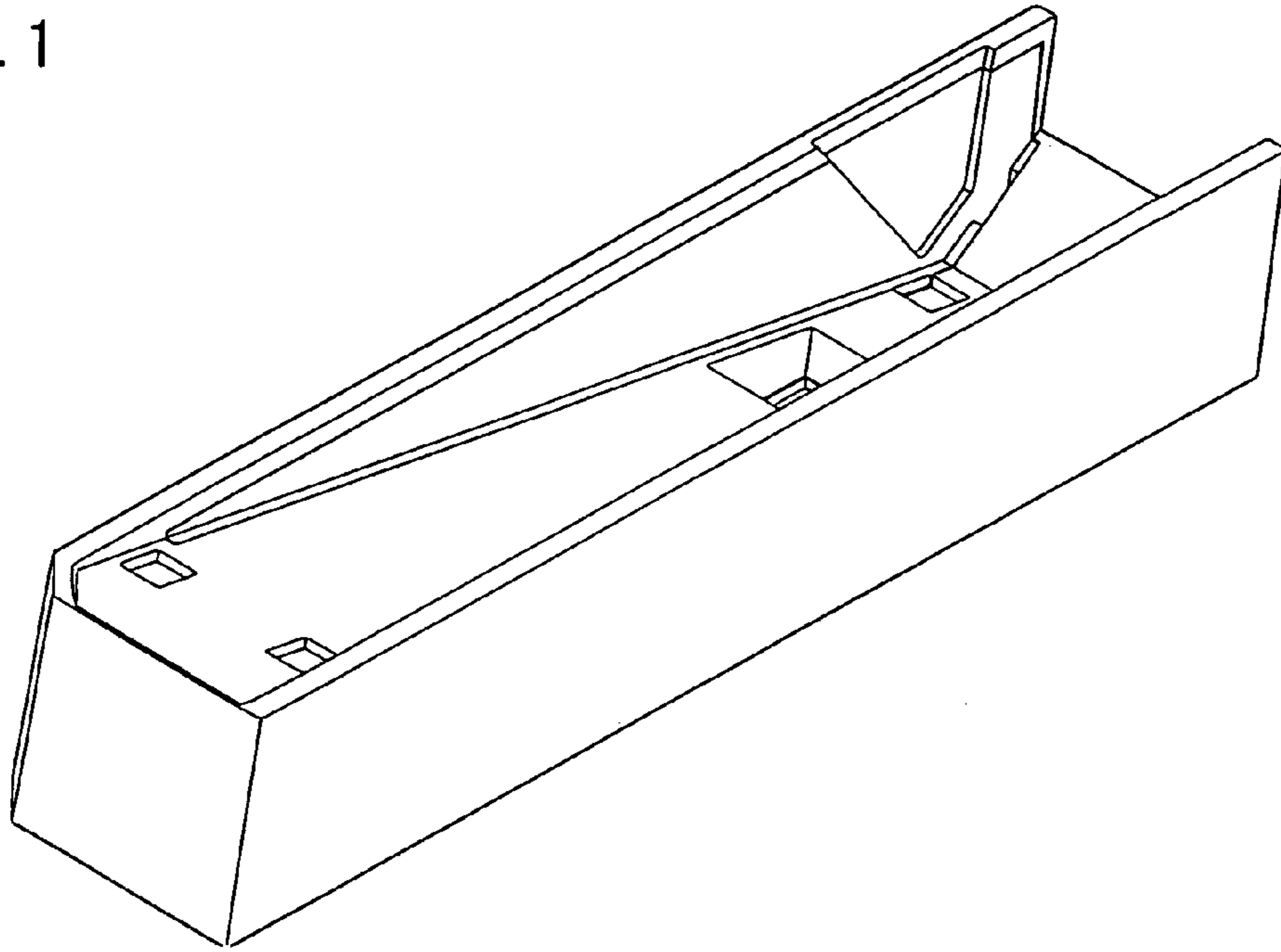

FIG. 2

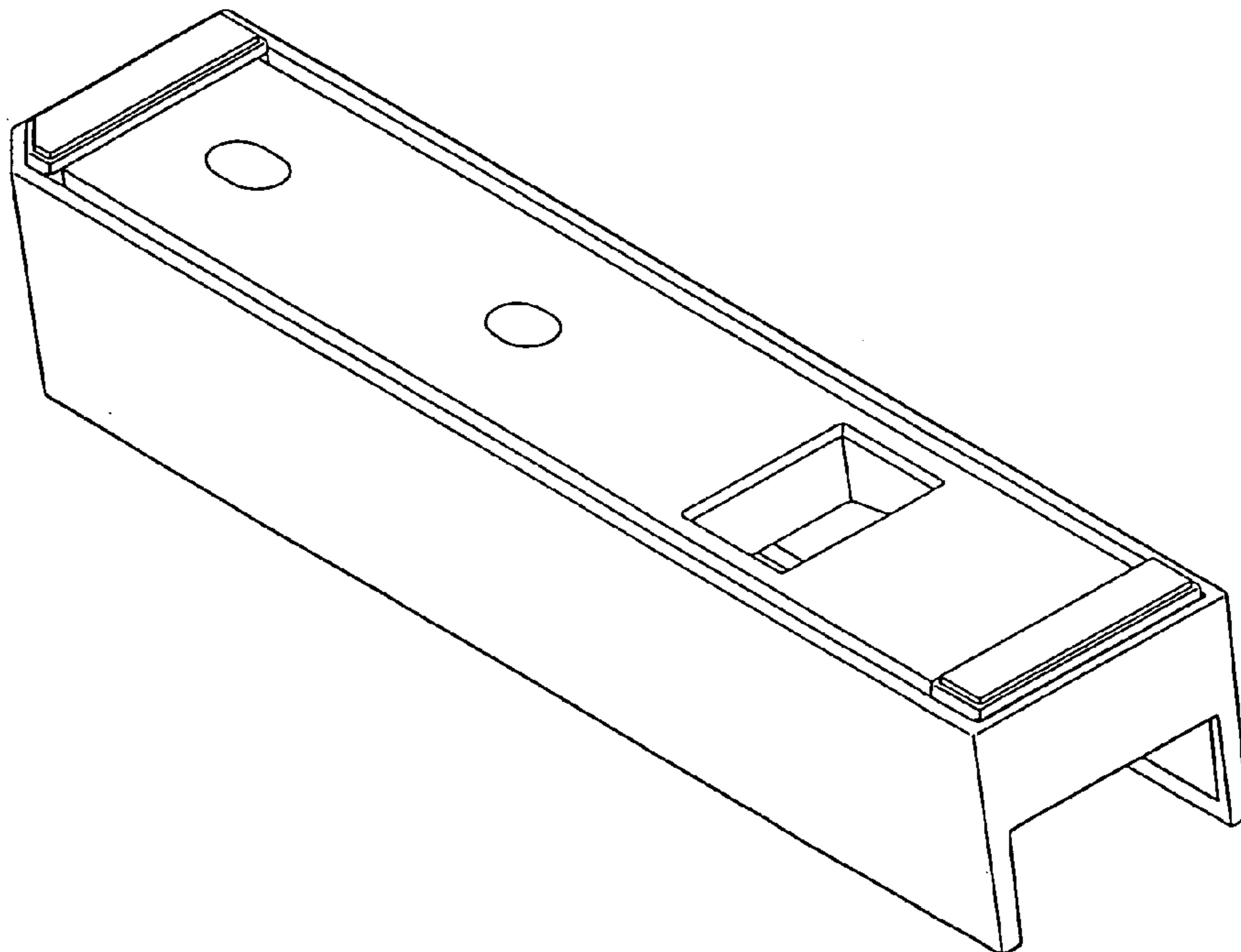

FIG. 3

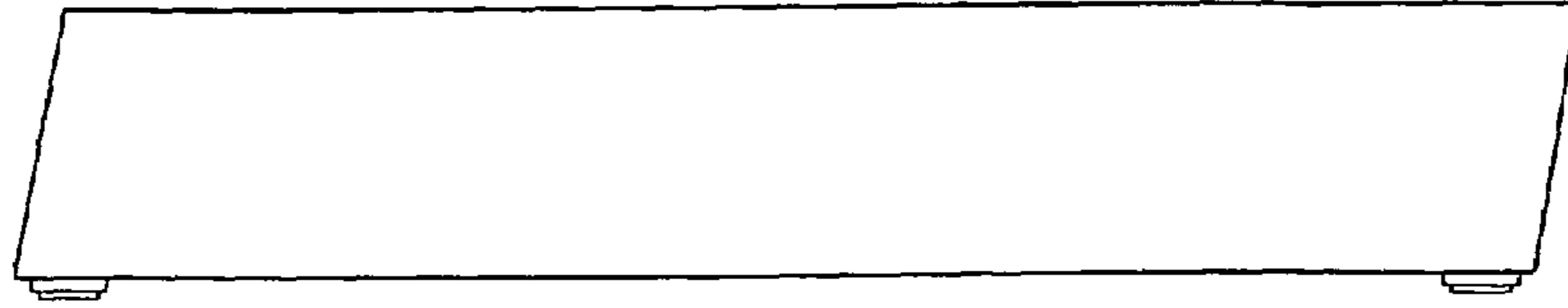

FIG. 4

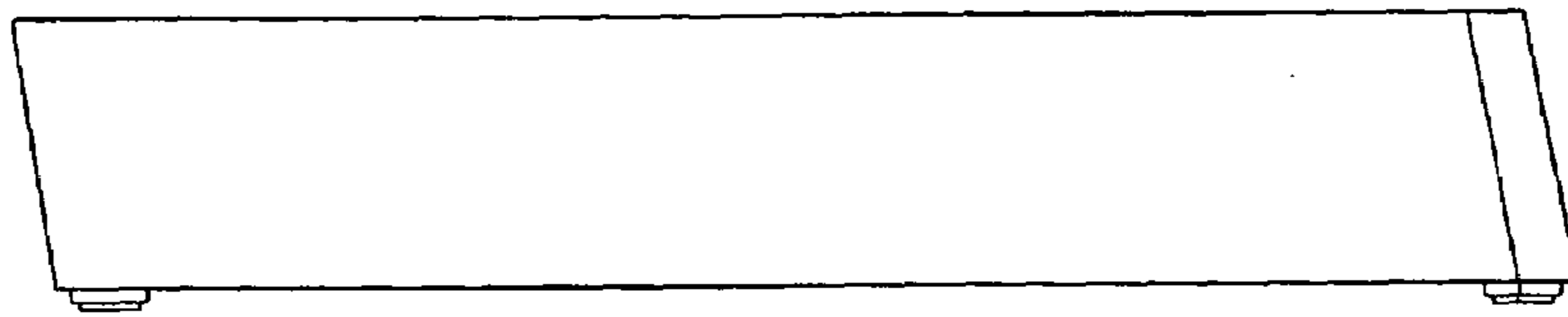

FIG. 5

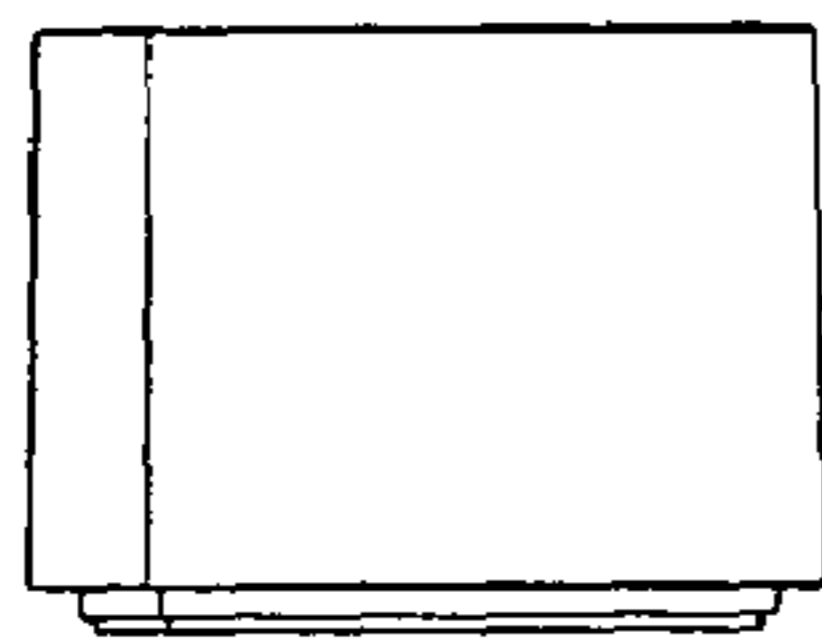

FIG. 6

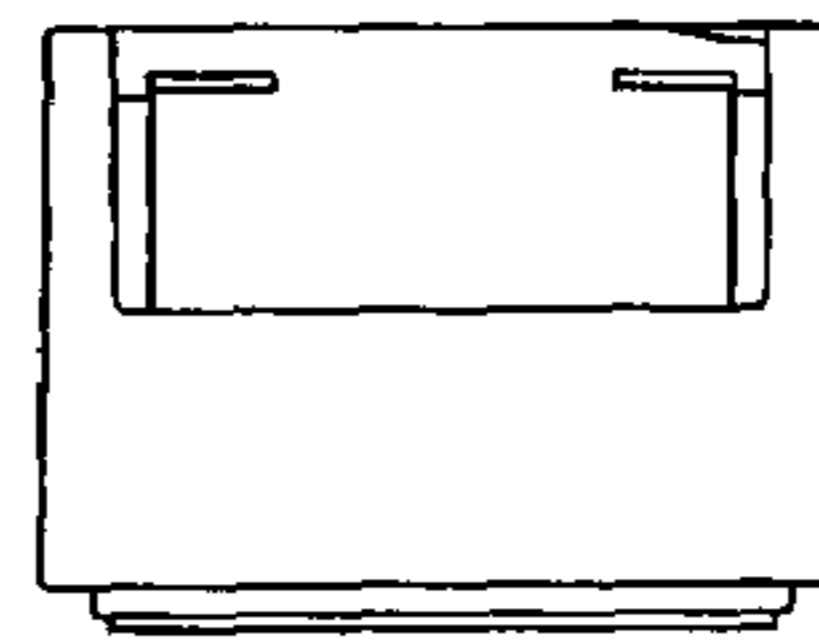

FIG. 7

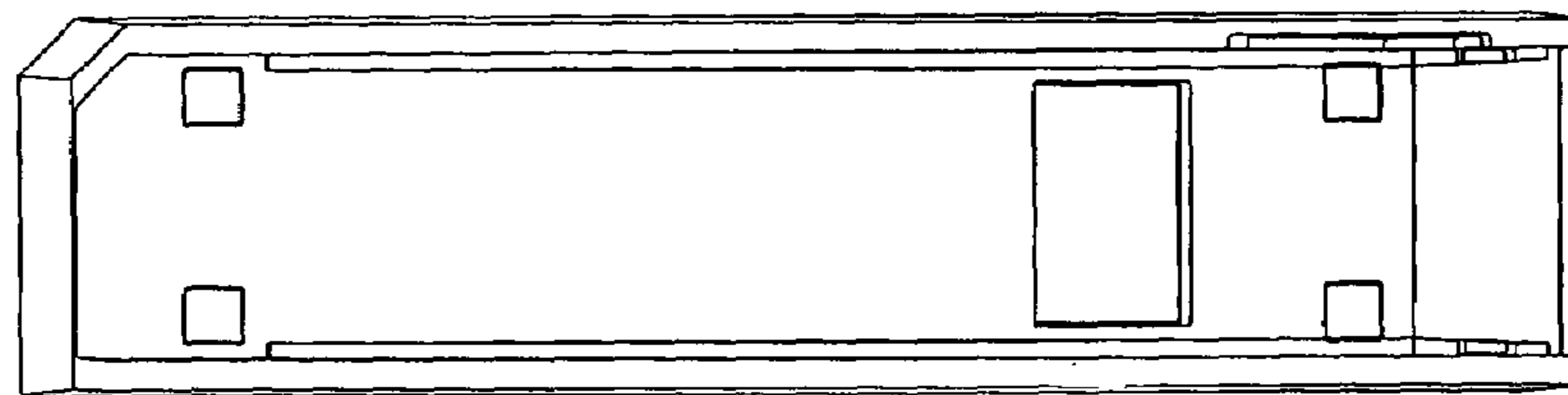

FIG. 8

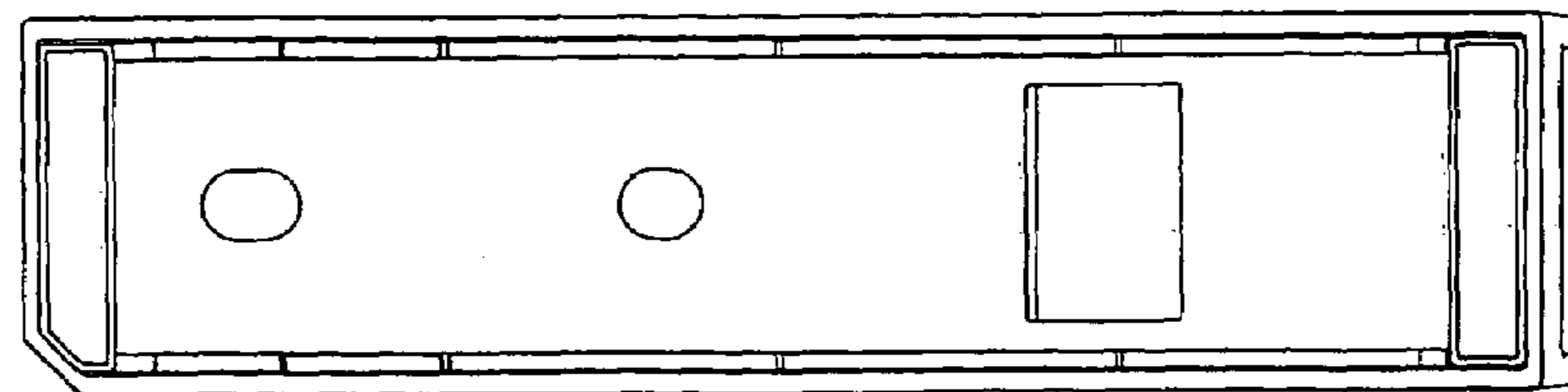

FIG. 9

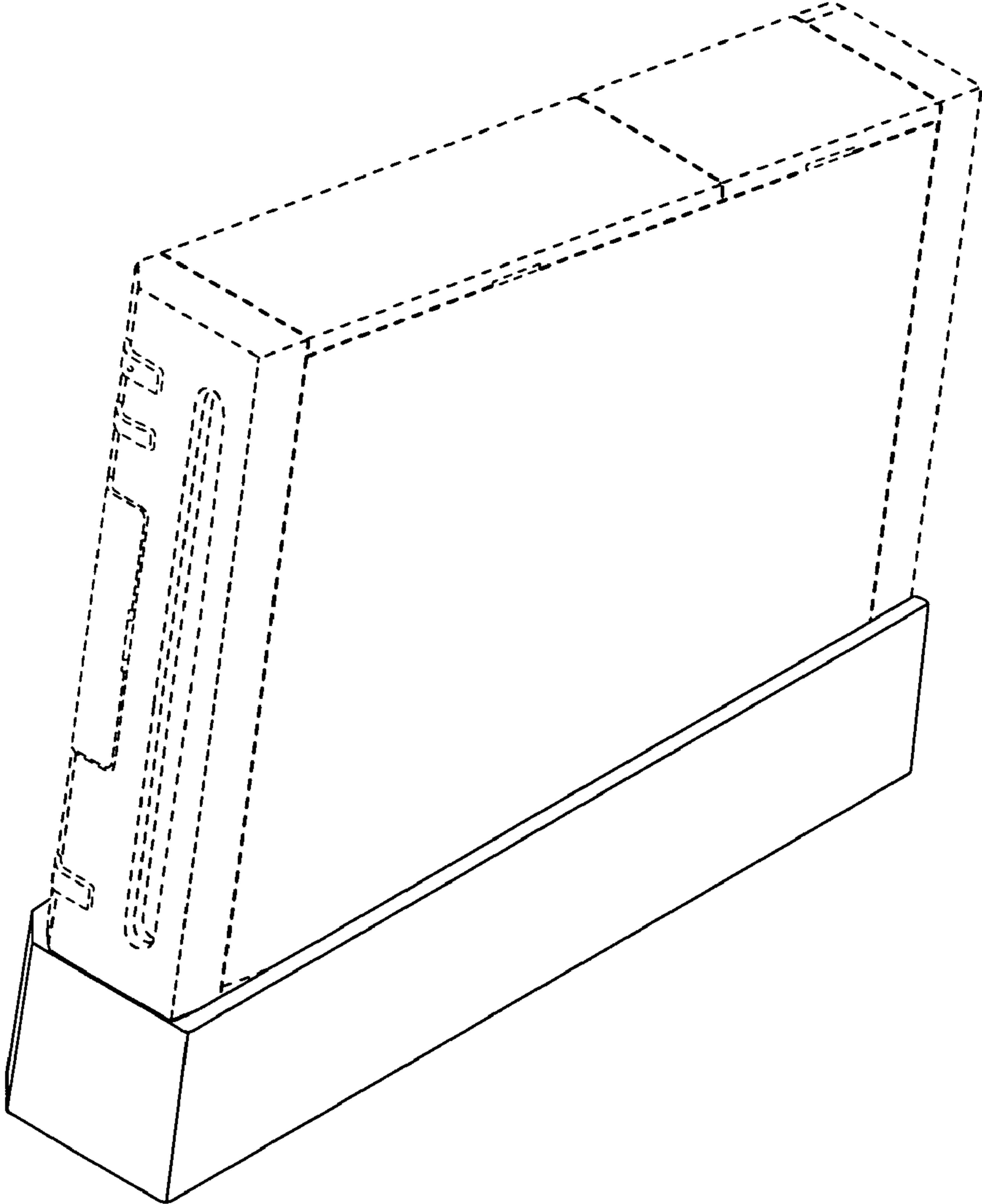

FIG. 10

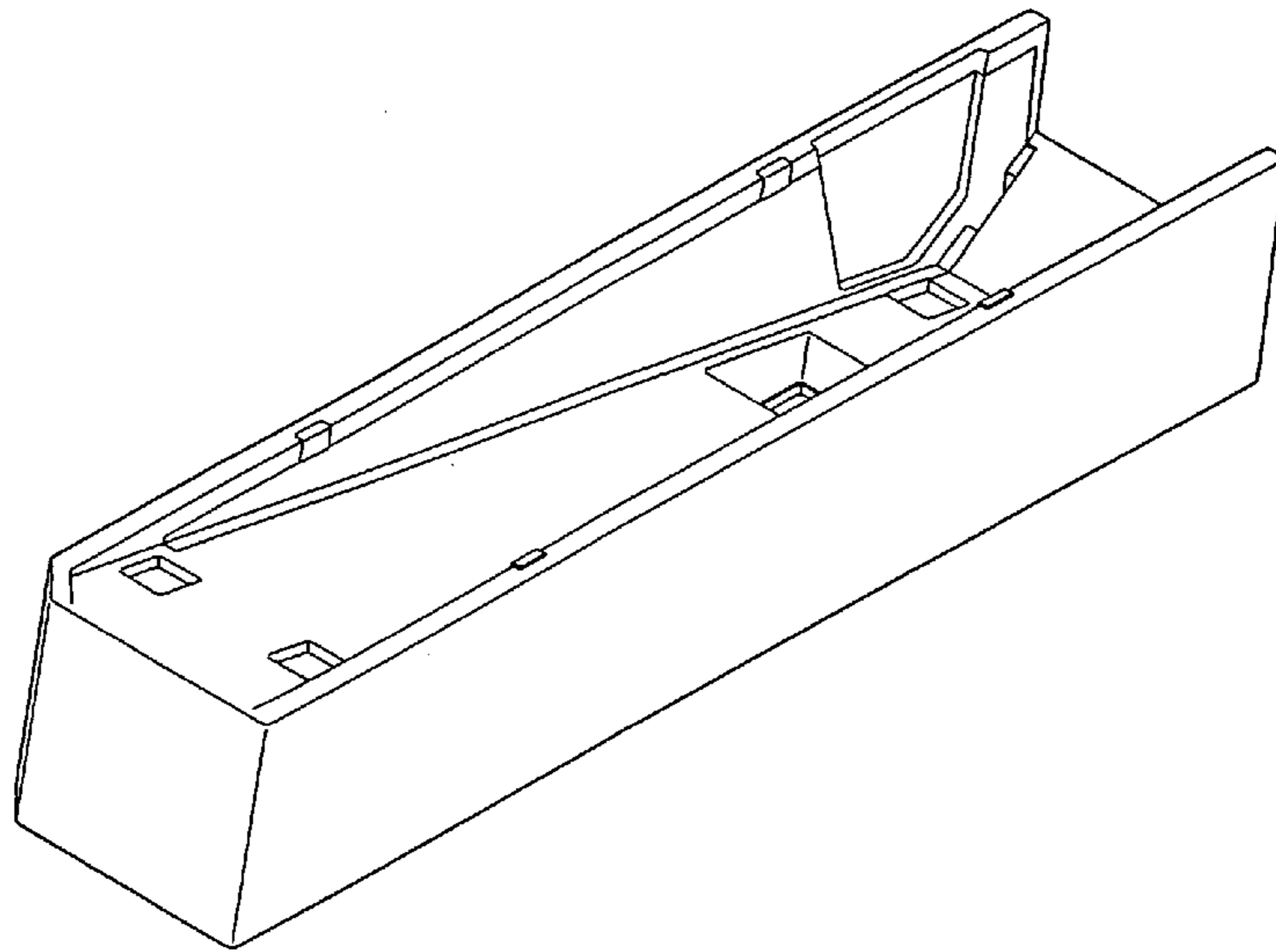

FIG. 11

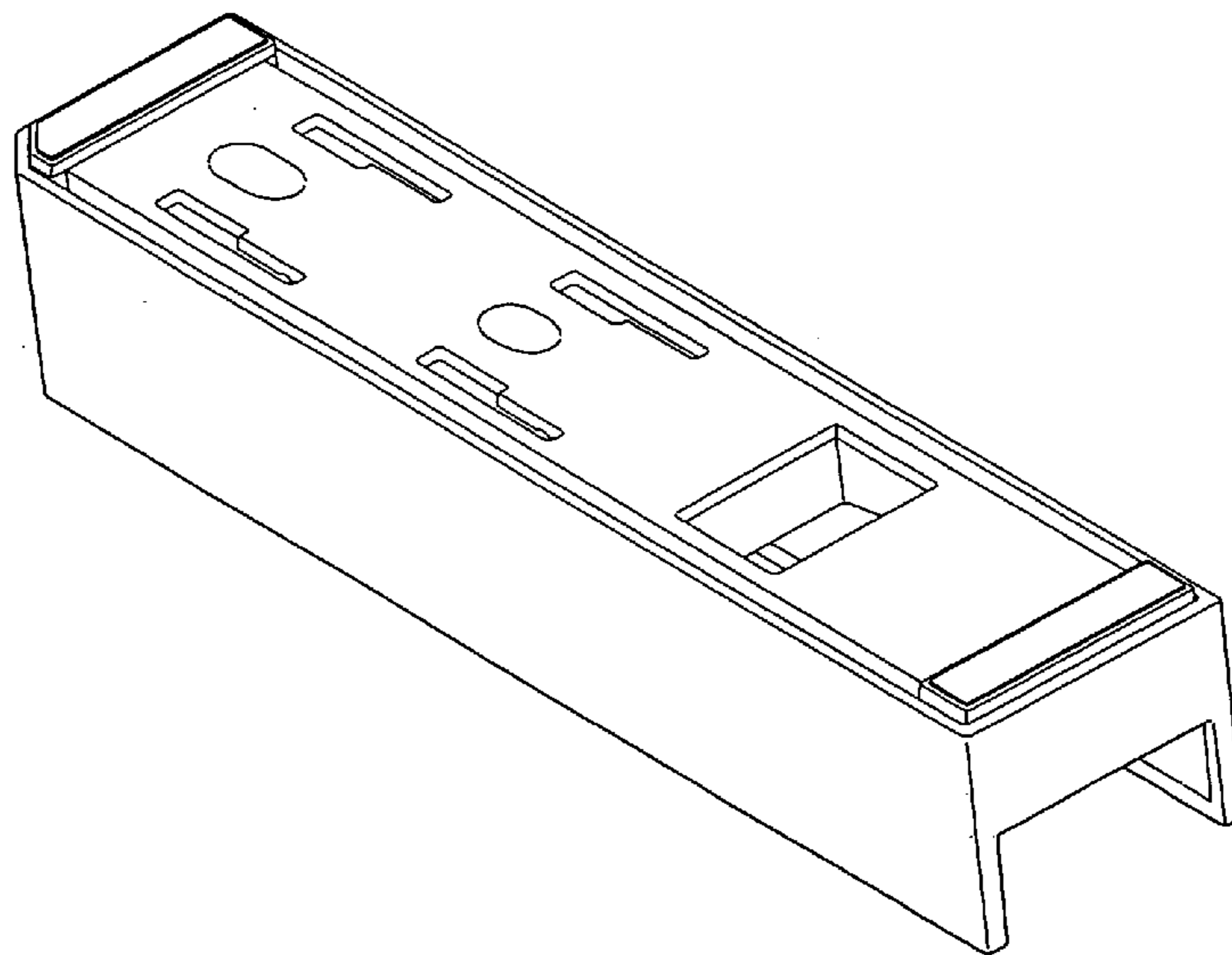

FIG. 12

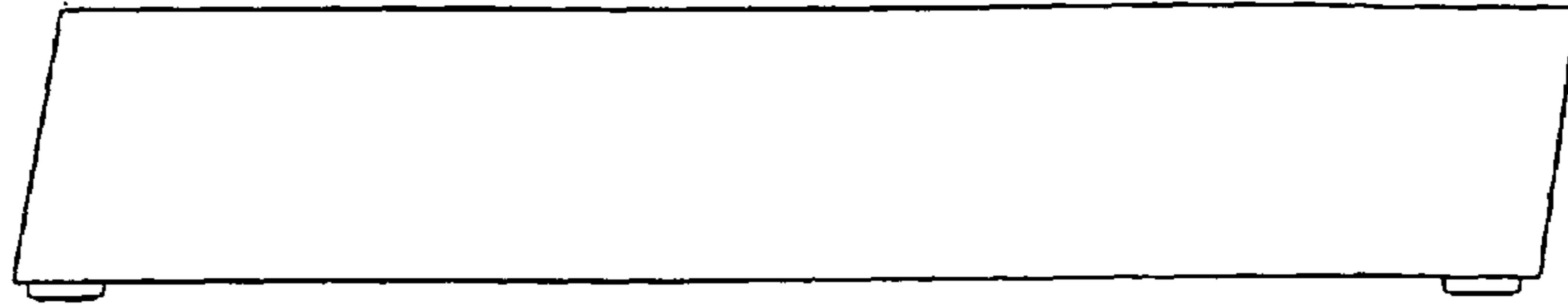

FIG. 13

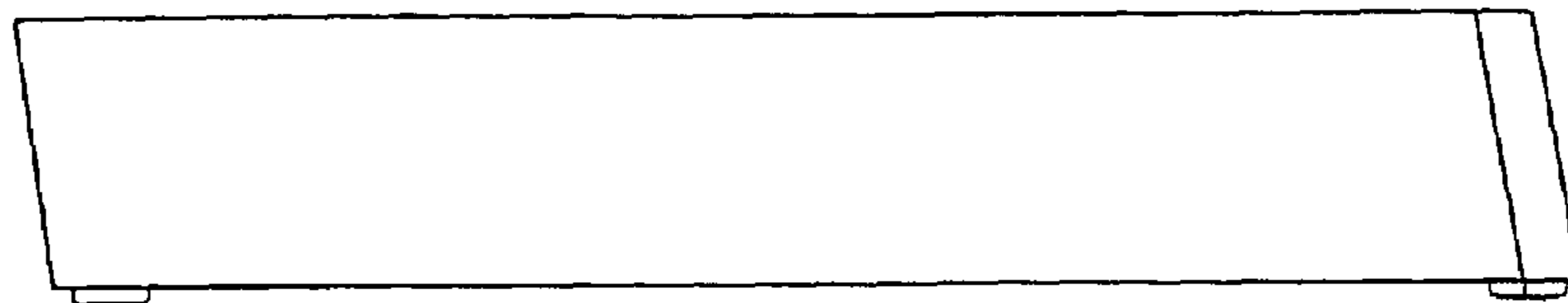

FIG. 14

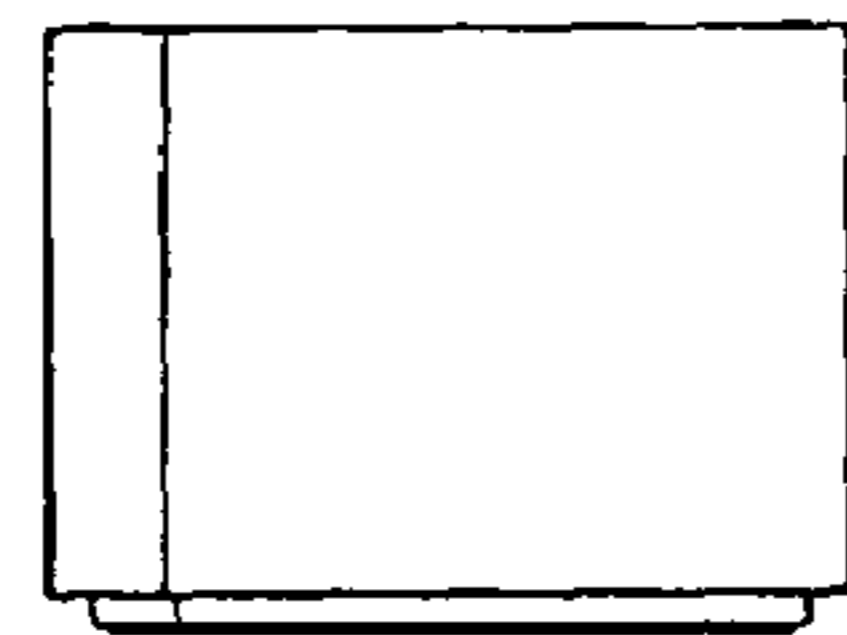

FIG. 15

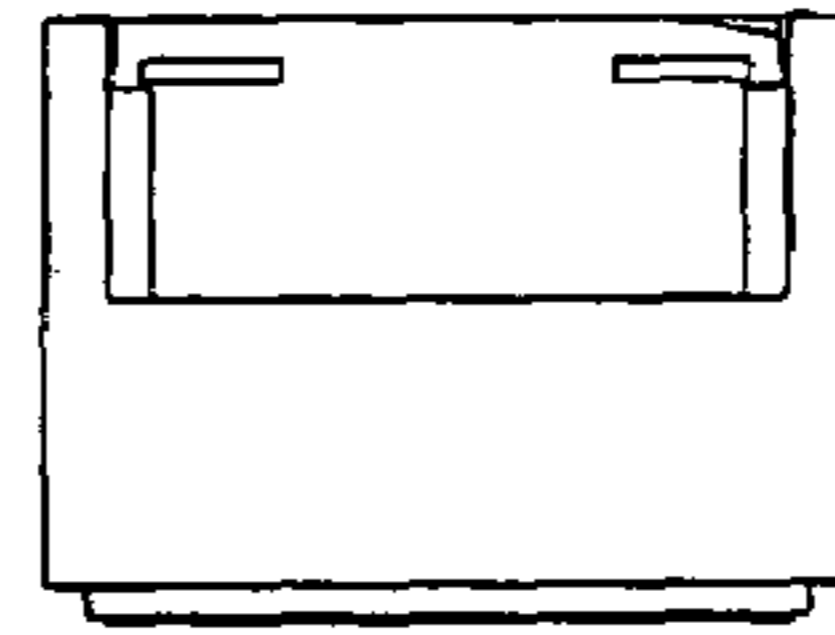

FIG. 16

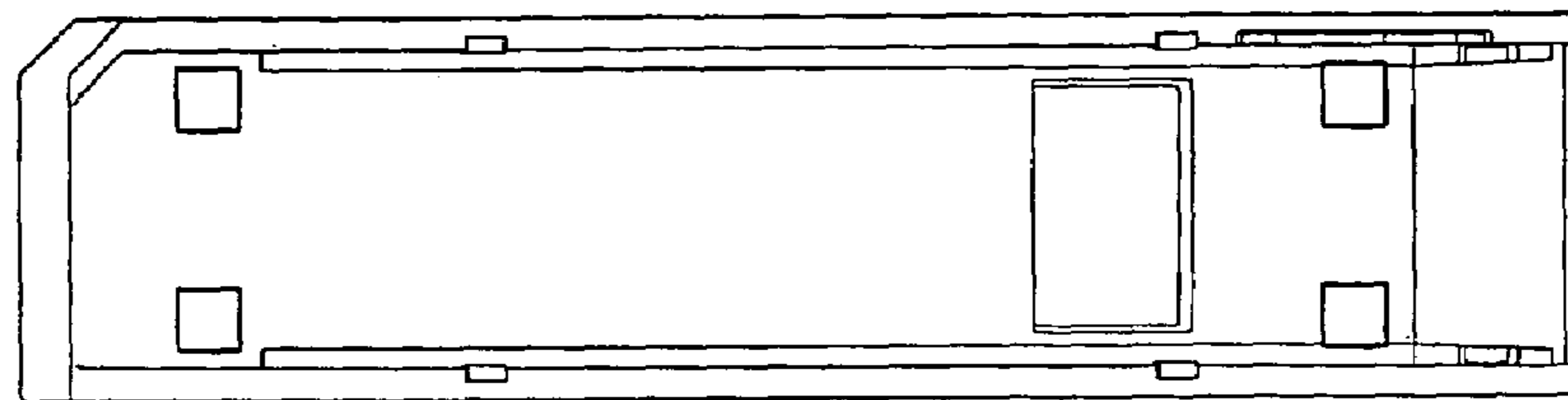

FIG. 17

